

PART NUMBER	ENGINEERING NO.	LENGTH
1300060991	104002A01F030	3' +1.75 - 0 [0.9M +44.5 - 0]
1300060995	104002A01F060	6' +2.19 - 0 [1.8M +55.6 - 0]
1300061002	104002A01F120	12' +3.50 - 0 [3.7M +88.9 - 0]
1300061009	104002A01F200	20' +6.50 - 0 [6.1M +165.1 - 0]

- NOTES:
1. MATERIAL: SEE TABLE
 2. FINISHES: SEE TABLE
 3. CABLE ASSEMBLIES ARE BAGGED SEPERATELY IN POLY BAGS WITH BARCODE LABEL ATTACHED TO OUTSIDE OF BAG
 4. WRAP LABEL IS MARKED WITH P/N, DATE CODE VOLTAGE & AMPERAGE
 5. MATES WITH: MINI CHANGE, A-SIZE 4 POLE RECEPTACLE
 6. ELECTRICAL SPECIFICATIONS:
VOLTAGE RATING: 600V
CURRENT RATING: 10 AMPS
 7. ASSEMBLY IS RoHS COMPLIANT

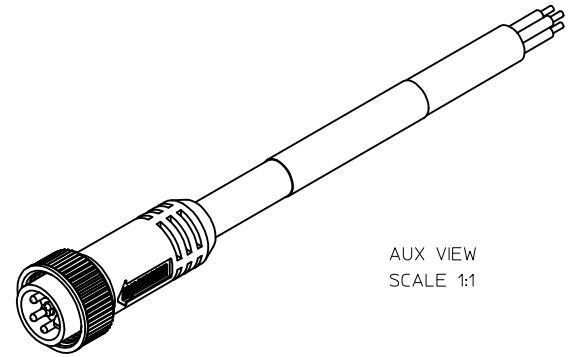

AUX VIEW
SCALE 1:1

P1	
1	BLACK
2	WHITE
3	RED
4	GREEN/YELLOW

WIRING DIAGRAM

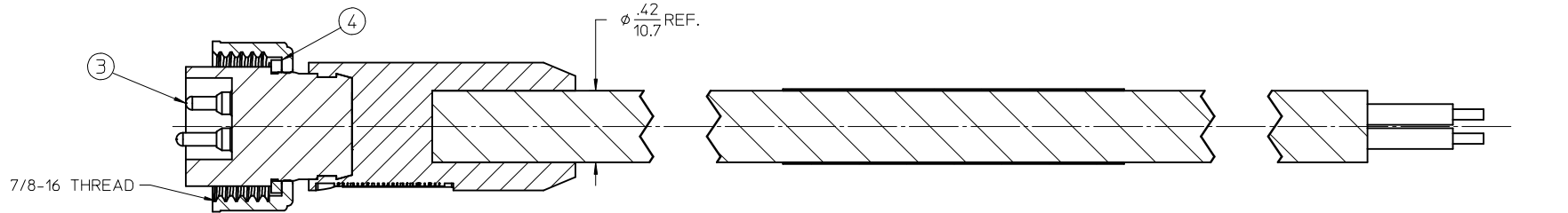

Section Z-Z

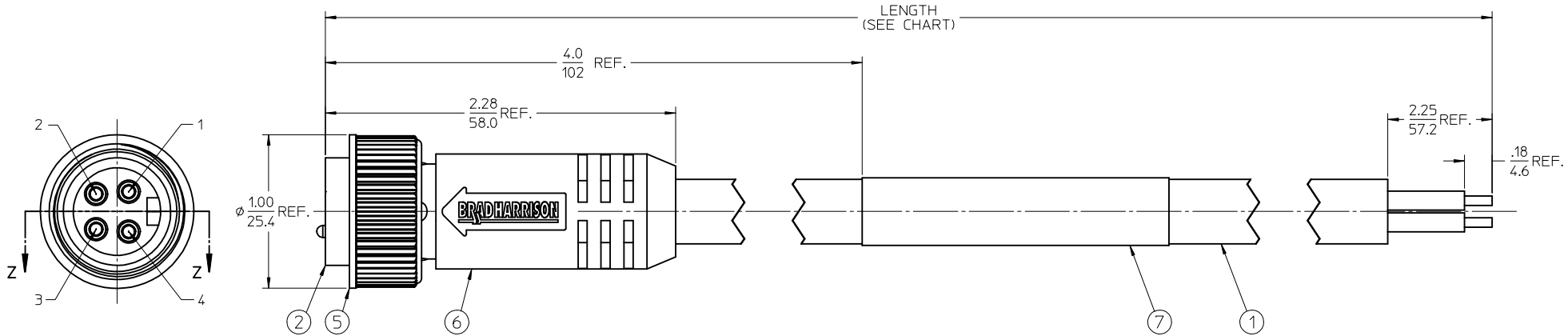

ITEM	QTY.	DESCRIPTION	MATERIAL	FINISH
7	1	LABEL	PLASTIC FILM	BLACK/YELLOW
6	1	OVERMOLD, STRAIGHT	PVC	YELLOW
5	1	COUPLING NUT, FEMALE	ZINC DIE CAST	BLACK
4	1	FRICION RING	NYLON	WHITE
3	4	CONTACT PIN, 16 AWG	BRASS	GOLD PLATED
2	1	INSERT, MALE, 4 POLE	PVC	YELLOW
1	1	CABLE, ST00W/ST #16/4	PVC JACKET	GRAY

PURCHASING DRAWING EC NO: WNA2009-0810 DRAWN: LHARTMANN 2009/06/09 CHKD: RSTONE APPR: JFMURPHY 2009/06/08	QUALITY SYMBOLS
	▽=0
	▽=0
	REV

GENERAL TOLERANCES (UNLESS SPECIFIED)	
mm	INCH
4 PLACES ± ---	± ---
3 PLACES ± ---	±.005
2 PLACES ± ---	±.010
1 PLACE ± ---	±.020
ANGULAR ±1/2°	
DRAFT WHERE APPLICABLE MUST REMAIN WITHIN DIMENSIONS	

DIMENSION STYLE	SCALE	DESIGN UNITS	THIRD ANGLE PROJECTION
IN/MM	2:1	INCH	
DRAWN BY	DATE	TITLE	
LHARTMANN	2009/06/05	MINI-CHANGE PORTABLE 4 POLE MALE STRAIGHT #16/4 YELLOW ST00W/ST	
CHECKED BY	DATE	MOLEX INCORPORATED	
RSTONE	2009/06/08		
APPROVED BY	DATE	DOCUMENT NO.	
JFMURPHY	2009/06/08	SD-130006-004	
MATERIAL NO.	SIZE	SHEET NO.	
SEE CHART	C	1 OF 1	

THIS DRAWING CONTAINS INFORMATION THAT IS PROPRIETARY TO MOLEX INCORPORATED AND SHOULD NOT BE USED WITHOUT WRITTEN PERMISSION

PART NUMBER	ENGINEERING NO.	LENGTH
1300060991	104002A01F030	3' +1.75 - 0 [0.9M +44.5 - 0]
1300060995	104002A01F060	6' +2.19 - 0 [1.8M +55.6 - 0]
1300061002	104002A01F120	12' +3.50 - 0 [3.7M +88.9 - 0]
1300061009	104002A01F200	20' +6.50 - 0 [6.1M +165.1 - 0]

- NOTES:
1. MATERIAL: SEE TABLE
 2. FINISHES: SEE TABLE
 3. CABLE ASSEMBLIES ARE BAGGED SEPERATELY IN POLY BAGS WITH BARCODE LABEL ATTACHED TO OUTSIDE OF BAG
 4. WRAP LABEL IS MARKED WITH P/N, DATE CODE VOLTAGE & AMPERAGE
 5. MATES WITH: MINI CHANGE, A-SIZE 4 POLE RECEPTACLE
 6. ELECTRICAL SPECIFICATIONS:
VOLTAGE RATING: 600V
CURRENT RATING: 10 AMPS
 7. ASSEMBLY IS RoHS COMPLIANT

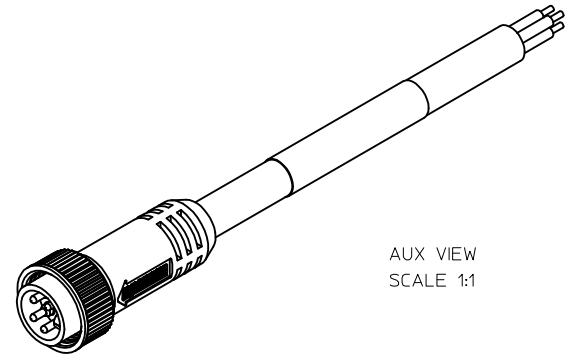

AUX VIEW
SCALE 1:1

P1	
1	BLACK
2	WHITE
3	RED
4	GREEN/YELLOW

WIRING DIAGRAM

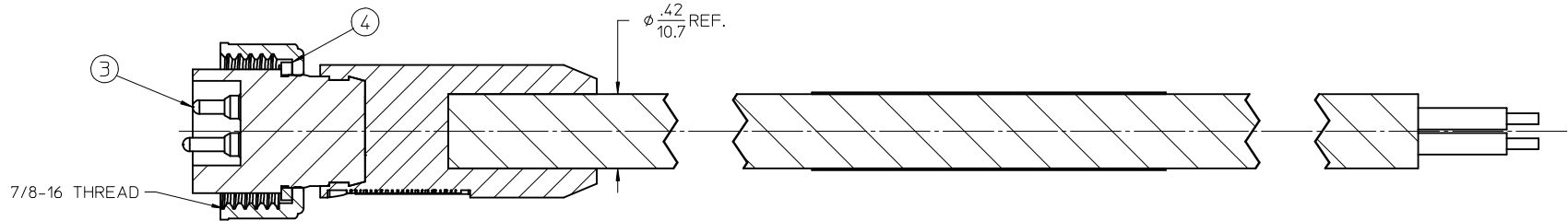

Section Z-Z

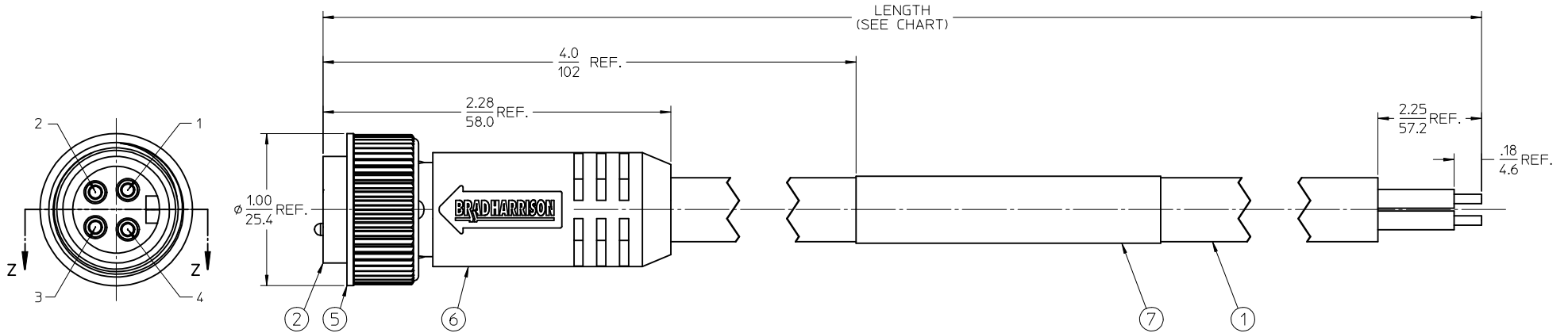

ITEM	QTY.	DESCRIPTION	MATERIAL	FINISH
7	1	LABEL	PLASTIC FILM	BLACK/YELLOW
6	1	OVERMOLD, STRAIGHT	PVC	YELLOW
5	1	COUPLING NUT, FEMALE	ZINC DIE CAST	BLACK
4	1	FRICION RING	NYLON	WHITE
3	4	CONTACT PIN, 16 AWG	BRASS	GOLD PLATED
2	1	INSERT, MALE, 4 POLE	PVC	YELLOW
1	1	CABLE, ST00W/ST #16/4	PVC JACKET	GRAY

PURCHASING DRAWING EC NO: WNA2009-0810 DRAWN: LHARTMANN 2009/06/09 CHKD: RSTONE APPR: JFMURPHY 2009/06/08	QUALITY SYMBOLS
	▽=0
	▽=0
	DESCRIPTION

GENERAL TOLERANCES (UNLESS SPECIFIED)	
	IN/CH
4 PLACES ±	---
3 PLACES ±	±.005
2 PLACES ±	±.010
1 PLACE ±	±.020
ANGULAR ±1/2°	

DRAFT WHERE APPLICABLE
MUST REMAIN
WITHIN DIMENSIONS

DIMENSION STYLE	
IN/MM	
DRAWN BY	DATE
LHARTMANN	2009/06/05
CHECKED BY	DATE
RSTONE	2009/06/08
APPROVED BY	DATE
JFMURPHY	2009/06/08
MATERIAL NO.	
SEE CHART	
SIZE	C

SCALE	DESIGN UNITS	THIRD ANGLE PROJECTION
2:1	INCH	☉
TITLE		
MINI-CHANGE PORTABLE 4 POLE MALE STRAIGHT #16/4 YELLOW ST00W/ST		
MOLEX INCORPORATED		SHEET NO.
DOCUMENT NO.		1 OF 1
THIS DRAWING CONTAINS INFORMATION THAT IS PROPRIETARY TO MOLEX INCORPORATED AND SHOULD NOT BE USED WITHOUT WRITTEN PERMISSION		

X-ON Electronics

Largest Supplier of Electrical and Electronic Components

Click to view similar products for [Sensor Cables / Actuator Cables](#) category:

Click to view products by [Molex](#) manufacturer:

Other Similar products are found below :

[60963](#) [60964](#) [703000D02F2002](#) [703001D02F0602](#) [703001D02F300](#) [704000D02F120](#) [773032K02F030](#) [802027107404-1](#) [802027213811-1](#)
[804001A09M150](#) [805001A09M0502](#) [84914-0235](#) [84914-0237](#) [885030A09M020](#) [8R4J30E03C3003](#) [1200651332](#) [1200651713](#) [1200660844](#)
[1200660845](#) [1200661173](#) [1200680071](#) [1200720053](#) [1200720081](#) [1200720099](#) [1200720217](#) [1200800231](#) [1200860125](#) [1200870123](#)
[1200980102](#) [1200650267](#) [1200650298](#) [1200660183](#) [1200660782](#) [1200660849](#) [1200661295](#) [1200661297](#) [1200661342](#) [1200661343](#)
[1200670080](#) [1200670220](#) [1200680331](#) [1200720252](#) [1200730184](#) [1200860344](#) [1200870359](#) [1200870643](#) [1200980008](#) [1200980031](#)
[1210502211](#) [1210400542](#)