

FACE VIEW - MALE INSERT

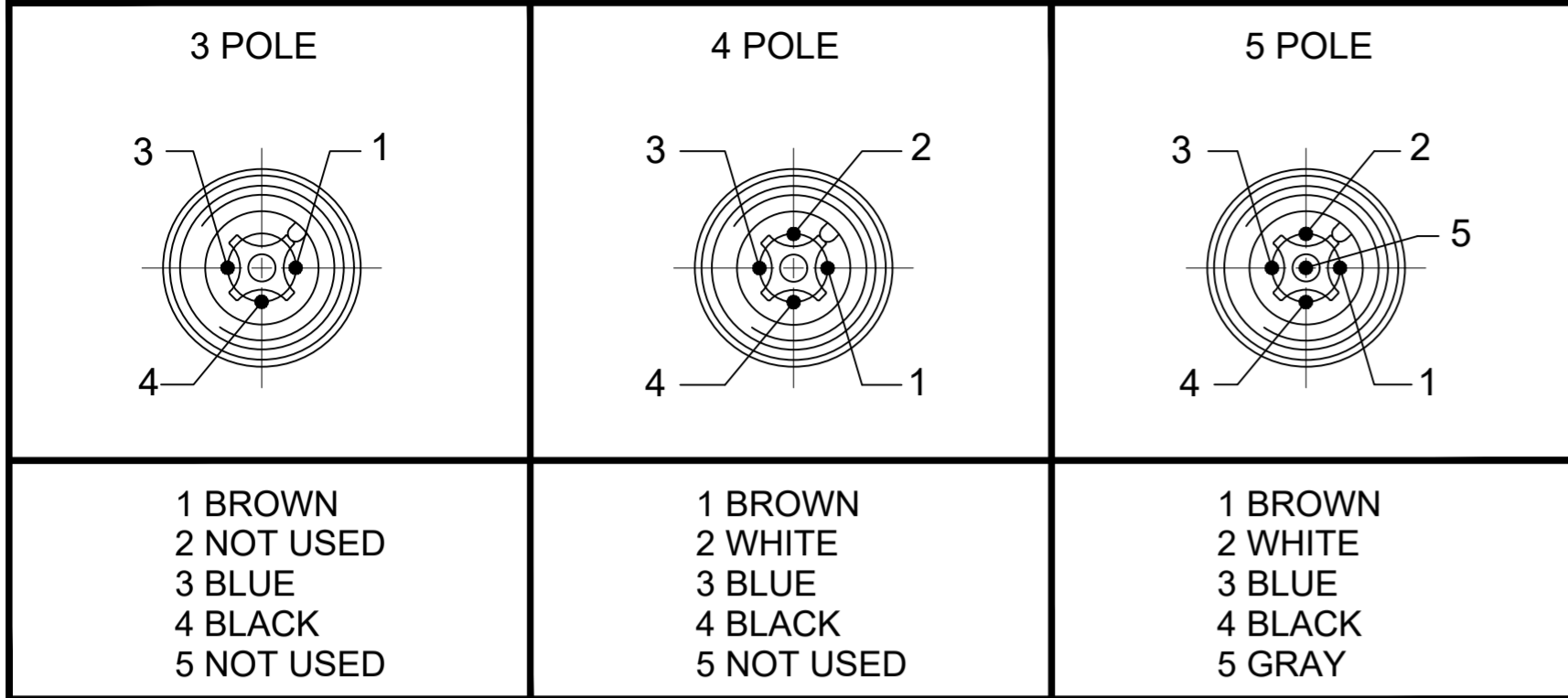

NOTES:

- MATERIAL: AS NOTED
- FINISH: AS NOTED
- ELECTRICAL:
VOLTAGE: 250V
CURRENT: 4A
- TEMP RATING: -20° TO +105°C (B)
- PROTECTION: IP67 (WHEN MATED)
- COUPLING THREAD: M12X1
- UL RECOGNIZED FILE: E152210
CSA CERTIFIED FILE: LR6837
- ALL DIMENSIONS ARE FOR REFERENCE
UNLESS TOLERANCED OR NOTED OTHERWISE

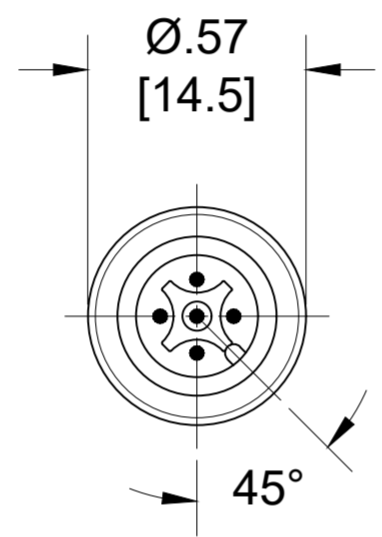

PART NO	ENGINEERING NO.	FINISHED LENGTH	POLES	CABLE DIA.
1200651113	803006K05M006	0.6M [2FT]	3	.20 [5.1]
1200652049	804006K05M150	15M [49FT 2 IN]	4	.21 [5.3]
1200652470	805006K05M300	30M [98FT 5 IN]	5	.23 [5.8]

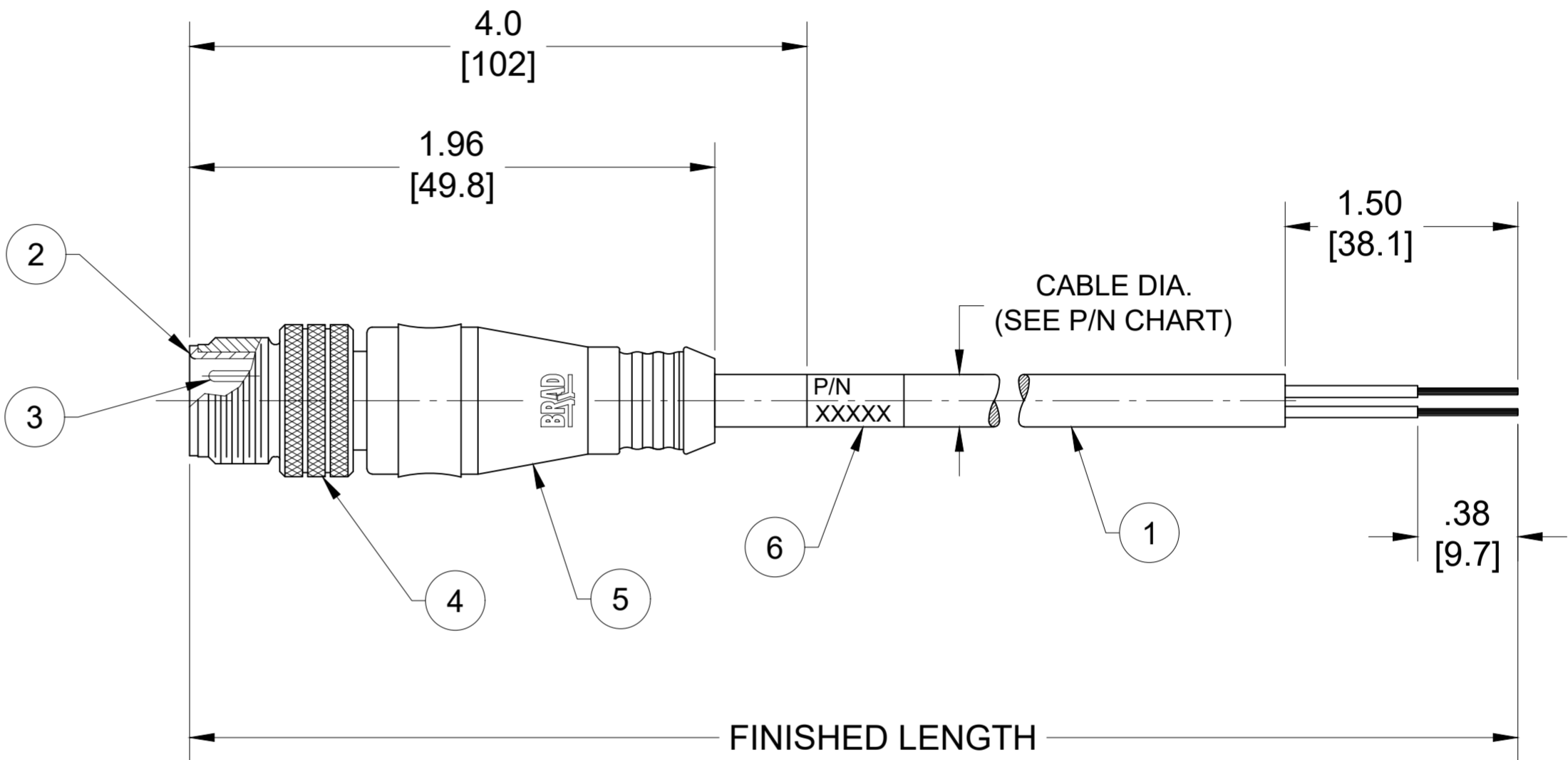

CABLE FLEX CHARACTERISTICS

TORSIONAL FLEX TEST	10 MILLION CYCLES PER MIL-C-13777G
BEND FLEX TEST	10 MILLION CYCLES PER MIL-C-13777G
WELD SLAG RESISTANCE	WOODHEAD STANDARD S-300

PART NO. MATRIX
803006K05M006

POLES (3, 4 & 5)
FINISHED LENGTH
M005 = 0.5 METER
M010 = 1 METER
M100 = 10 METER

CABLE LENGTH TOLERANCES

<.3M [1FT]:	+19mm-0 [+ .75in-0]
.3 - .9M [1 - 3FT]:	+44.5mm-0 [+1.75in-0]
.9 - 1.8M [3 - 6FT]:	+55.6mm-0 [+2.19in-0]
1.8 - 3.7M [6 - 12FT]:	+88.9mm-0 [+3.50in-0]
3.7 - 7.3M [12 - 24FT]:	+165.1mm-0 [+6.50in-0]
7.3-14.6M [24 - 48FT]:	+317.5mm-0 [+12.50in-0]
14.6 - 30.5M [48-100FT]:	+622.3mm-0 [+24.50in-0]
OVER 30M [100FT]:	+2% OF FINISHED LENGTH

ITEM	DESCRIPTION	MATERIAL	FINISH
6	WRAP LABEL	VINYL	BLACK/YELLOW
5	OVERMOLD	TPC	YELLOW
4	COUPLING NUT	BRASS	NICKEL PLATED
3	CONTACT PIN	COPPER ALLOY	GOLD OVER NICKEL
2	MALE INSERT	PUR	BLACK
1	#22 AWG CABLE	TPE JACKET	YELLOW

THIS DRAWING CONTAINS INFORMATION THAT IS PROPRIETARY TO MOLEX ELECTRONIC TECHNOLOGIES, LLC AND SHOULD NOT BE USED WITHOUT WRITTEN PERMISSION

FUNCTIONAL SYMBOLS	DIMENSION UNITS: INCH/MM	SCALE: NTS	CURRENT REV DESC: ITEM #6 WAS TPE. MODIFIED TEMP RATING & PN CHART
DIVISIONAL SYMBOLS	GENERAL TOLERANCES (UNLESS SPECIFIED)		EC NO: 671333 DRWN: ABENJAMINLW 2021/04/30 CHK'D: RSTONE 2021/07/23 APPR: BWOODMAN 2021/07/28
	4 PLACES	±----	
	3 PLACES	±----	±----
	2 PLACES	±----	±----
	1 PLACE	±----	±----
	0 PLACES	±----	±----
	ANGULAR TOL ± ---- °		
	DRAFT WHERE APPLICABLE MUST REMAIN WITHIN DIMENSIONS	THIRD ANGLE PROJECTION	DRAWING: C-SIZE
		SERIES: 120065	MATERIAL NUMBER: SEE CHART
		CUSTOMER: GENERAL MARKET	SHEET NUMBER: 1 OF 1

molex

MICRO-CHANGE CORDSET, M12, 3-5 POLE, MALE, STRAIGHT, SINGLE KEY, #22 AWG TPE HI-FLEX

PRODUCT CUSTOMER DRAWING

DOCUMENT NUMBER: SD-120065-114
DOC TYPE/DOC PART/REVISION: PSD 001 B

X-ON Electronics

Largest Supplier of Electrical and Electronic Components

Click to view similar products for [Sensor Cables / Actuator Cables](#) category:

Click to view products by [Molex](#) manufacturer:

Other Similar products are found below :

[60963](#) [60964](#) [703000D02F2002](#) [703001D02F0602](#) [703001D02F300](#) [704000D02F120](#) [773032K02F030](#) [802027107404-1](#) [802027213811-1](#)
[804001A09M150](#) [805001A09M0502](#) [84914-0235](#) [84914-0237](#) [885030A09M020](#) [8R4J30E03C3003](#) [1200651332](#) [1200651713](#) [1200660844](#)
[1200660845](#) [1200661173](#) [1200680071](#) [1200720053](#) [1200720081](#) [1200720099](#) [1200720217](#) [1200800231](#) [1200860125](#) [1200870123](#)
[1200980102](#) [1200650267](#) [1200650298](#) [1200660183](#) [1200660782](#) [1200660849](#) [1200661295](#) [1200661297](#) [1200661342](#) [1200661343](#)
[1200670080](#) [1200670220](#) [1200680331](#) [1200720252](#) [1200730184](#) [1200860344](#) [1200870359](#) [1200870643](#) [1200980008](#) [1200980031](#)
[1210502211](#) [1210400542](#)