

**MALE FACE VIEW**

**3-POLE**

**4-POLE**

**5-POLE**

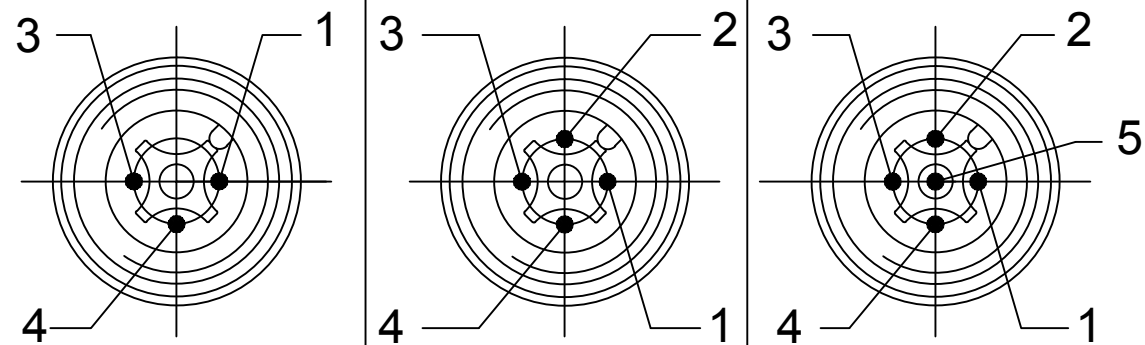

**WIRING DIAGRAM**

1 BROWN 3 BLUE 4 BLACK	1 BROWN 2 WHITE 3 BLUE 4 BLACK	1 BROWN 2 WHITE 3 BLUE 4 BLACK 5 GRAY
------------------------------	---	---

PART NO.	ENGINEERING NO.	FINISHED LENGTH	POLES	CABLE DIA
1200651501	803007K05M020	2.0M [6'7"]	3	.20/5.1
1200651692	804007K05M040	4.0M [13'1"]	4	.21/5.3
1200652477	805007K05M100	10.0M [32'10"]	5	.23/5.8

**PART NO. LEGEND**

**803007K05M020**

POLES: 3,4 & 5

CABLE TYPE  
22AWG  
TPE YELLOW

FINISHED LENGTH  
M005----0.5 Meters  
M010----1.0 Meter  
M100----10 Meters

**NOTES:**

- MATERIAL: AS NOTED
- FINISH: AS NOTED
- ELECTRICAL:  
VOLTAGE: 250V  
CURRENT: 4A
- TEMP RATING: -25°TO +105°C
- PROTECTION: IP67 (WHEN MATED)
- COUPLING THREAD: M12 X 1
- UL RECOGNIZED FILE: E152210  
CSA CERTIFIED FILE: LR6837
- ALL DIMS ARE FOR REFERENCE UNLESS NOTED OTHERWISE

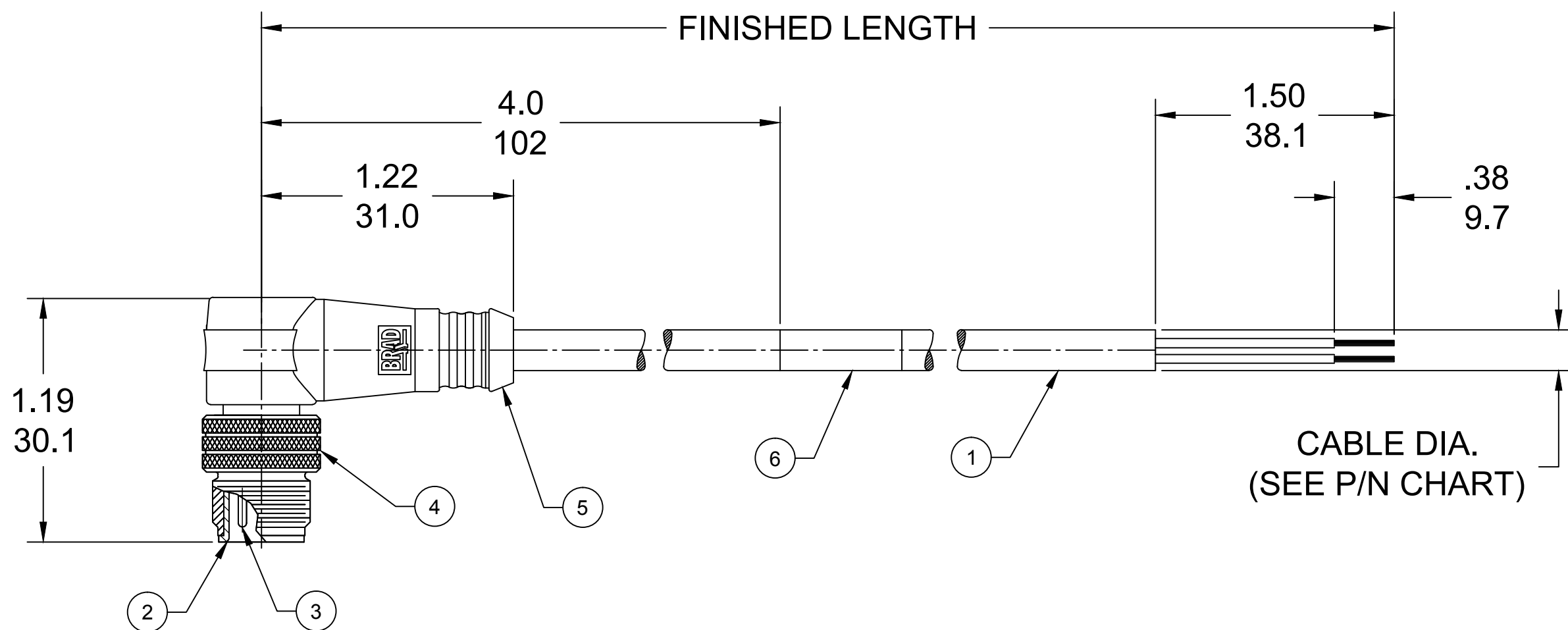

**CABLE FLEX CHARACTERISTICS**

TORSIONAL FLEX TEST	10 MILLION CYCLES PER MIL-C-13777G
BEND FLEX TEST	10 MILLION CYCLES PER MIL-C-13777G
WELD SLAG RESISTANCE	WOODHEAD STANDARD S-300

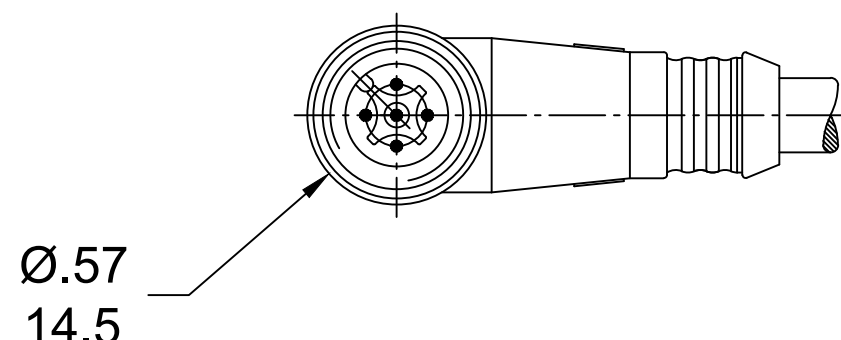

**CABLE LENGTH TOLERANCES**

>.3M [1FT]:	+19mm-0 [+1.75in-0]
.3 - .9M [1 - 3FT]:	+44.5mm-0 [+1.75in-0]
.9 - 1.8M [3 - 6FT]:	+55.6mm-0 [+2.19in-0]
1.8 - 3.7M [6 - 12FT]:	+88.9mm-0 [+3.50in-0]
3.7 - 7.3M [12 - 24FT]:	+165.1mm-0 [+6.50in-0]
7.3-14.6M [24 - 48FT]:	+317.5mm-0 [+12.50in-0]
14.6 - 30.5M [48-100FT]:	+622.3mm-0 [+24.50in-0]
OVER 30M [100FT]	+2% OF FINISHED LENGTH

ITEM	DESCRIPTION	MATERIAL	FINISH
6	WRAP LABEL	VINYL	BLACK/YELLOW
5	OVERMOLD	TPE	YELLOW
4	COUPLING NUT	BRASS	NICKEL PLATED
3	CONTACT PIN	COPPER ALLOY	GOLD PLATED
2	MALE INSERT	PUR	BLACK
1	CABLE, 22AWG, 300V, 105°	TPE JACKET	YELLOW

EC NO: ICG2019-0189 DRWN: RSTONE 2018/11/01 CHKD: C CHRAST 2018/11/07 APPR: BWOODMAN2018/11/30 RELEASED	QUALITY SYMBOL	GENERAL TOLERANCES (UNLESS SPECIFIED)	DIMENSION STYLE	SCALE	DESIGN UNITS	THIRD ANGLE PROJECTION	
	▽=0 ∇=0	mm INCH	IN/MM	---	INCH		
		4 PLACES ±--- ±--- 3 PLACES ±--- ±--- 2 PLACES ±--- ±--- 1 PLACE ±--- ±---	DRAWN BY DATE RSTONE 2018/11/01 CHECKED BY DATE C CHRAST 2018/11/07 APPROVED BY DATE BWOODMAN 2018/11/30	TITLE	MIC CABLE ASSY M12 MALE 90 DEG 22AWG, TPE, YELLOW MOLEX INCORPORATED		
		ANGULAR ±---°	MATERIAL NO. SEE P/N CHART	DOCUMENT NO. SD-120065-115			
		DRAFT WHERE APPLICABLE MUST REMAIN WITHIN DIMENSIONS	SIZE C	THIS DRAWING CONTAINS INFORMATION THAT IS PROPRIETARY TO MOLEX INCORPORATED AND SHOULD NOT BE USED WITHOUT WRITTEN PERMISSION			

## X-ON Electronics

Largest Supplier of Electrical and Electronic Components

*Click to view similar products for [Sensor Cables / Actuator Cables](#) category:*

*Click to view products by [Molex](#) manufacturer:*

Other Similar products are found below :

[60963](#) [60964](#) [703000D02F2002](#) [703001D02F0602](#) [703001D02F300](#) [704000D02F120](#) [773032K02F030](#) [802027107404-1](#) [802027213811-1](#)  
[804001A09M150](#) [805001A09M0502](#) [84914-0235](#) [84914-0237](#) [885030A09M020](#) [8R4J30E03C3003](#) [1200651332](#) [1200651713](#) [1200660844](#)  
[1200660845](#) [1200661173](#) [1200680071](#) [1200720053](#) [1200720081](#) [1200720099](#) [1200720217](#) [1200800231](#) [1200860125](#) [1200870123](#)  
[1200980102](#) [1200650267](#) [1200650298](#) [1200660183](#) [1200660782](#) [1200660849](#) [1200661295](#) [1200661297](#) [1200661342](#) [1200661343](#)  
[1200670080](#) [1200670220](#) [1200680331](#) [1200720252](#) [1200730184](#) [1200860344](#) [1200870359](#) [1200870643](#) [1200980008](#) [1200980031](#)  
[1210502211](#) [1210400542](#)