

PART NO.	ENGINEERING NO.	FINISHED LENGTH
1200662179	885030K03M005E	0.5M (1FT 8IN)
1200662180	885030K03M010E	1.0M (3FT 3IN)
1200662189	885030K03M100E	10.0M (32FT 10IN)

CABLE LENGTH TOLERANCES	
>.3M [1FT]:	+19mm-0 [+ .75in-0]
.3 - .9M [1 - 3FT]:	+44.5mm-0 [+1.75in-0]
.9 - 1.8M [3 - 6FT]:	+55.6mm-0 [+2.19in-0]
1.8 - 3.7M [6 - 12FT]:	+88.9mm-0 [+3.50in-0]
3.7 - 7.3M [12 - 24FT]:	+165.1mm-0 [+6.50in-0]
7.3-14.6M [24 - 48FT]:	+317.5mm-0 [+12.50in-0]
14.6 - 30.5M [48-100FT]:	+622.3mm-0 [+24.50in-0]
OVER 30M [100FT]:	+2% OF FINISHED LENGTH

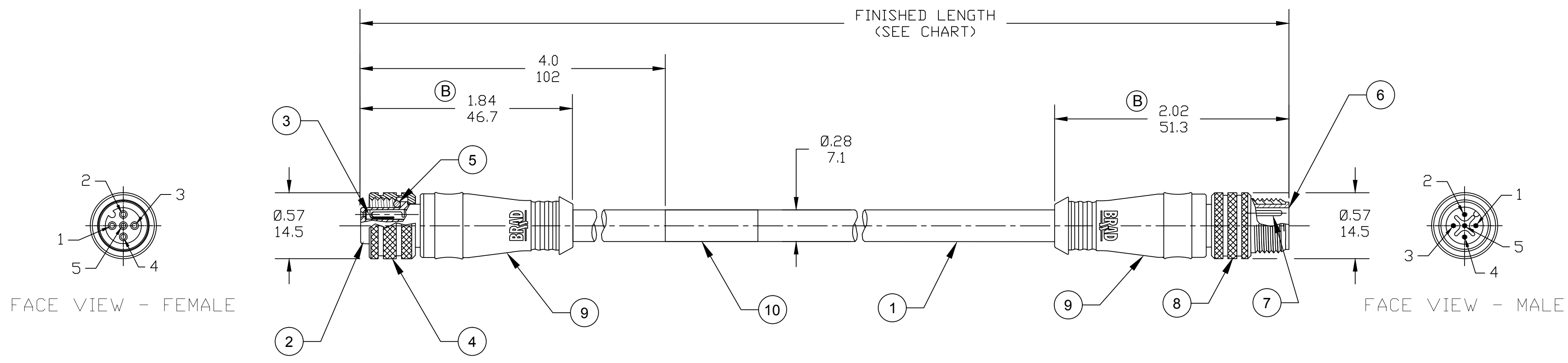

- NOTES:**
1. MATERIAL: AS NOTED
  2. FINISH: AS NOTED
  3. ELECTRICAL:  
VOLTAGE: 250V  
CURRENT: 4A
  4. TEMP RATING: -25°TO +105°C
  5. PROTECTION: IP67 (WHEN MATED)
  6. COUPLING THREAD: M12 X 1.0
  7. ALL DIMS ARE FOR REFERENCE UNLESS TOLERANCED OR NOTED OTHERWISE

1	BROWN	1
2	WHITE	2
3	BLUE	3
4	BLACK	4
5	GRAY	5

**PART NUMBER LEGEND**

885030K03M005E

CABLE TYPE: 18/5 PLTC HI-FLEX

RED OVERMOLD

FINISHED LENGTH:  
M005= 0.5 METER  
M010= 1 METER  
M100= 10 METER

ITEM	DESCRIPTION	MATERIAL	FINISH
10	FLAG LABEL	VINYL	BLACK/YELLOW
9	OVERMOLDS	TPC	RED
8	COUPLING, MALE	BRASS	NICKEL PLATED
7	CONTACT PIN	COPPER ALLOY	GOLD PLATED
6	MALE INSERT 5P	NYLON	BLACK
5	O-RING	VITON	RED
4	COUPLING, FEMALE	BRASS	NICKEL PLATED
3	CONTACT SOCKET	COPPER ALLOY	GOLD PLATED
2	FEMALE INSERT 5P	NYLON	BLACK
1	CABLE, 18/5, PLTC, FT4	TPE JACKET	YELLOW

REV D O-MOLD LENGTHS

EC NO: IPG2019-0533

DRWN: RSTONE 5/30/19

CHKD: J CAPPOZ

APPR: BWOODMAN2019/04/18

QUALITY SYMBOL

▽=0

▽C=0

GENERAL TOLERANCES (UNLESS SPECIFIED)	
	mm INCH
4 PLACES	±--- ±---
3 PLACES	±--- ±---
2 PLACES	±--- ±---
1 PLACE	±--- ±---
ANGULAR ±---°	
DRAFT WHERE APPLICABLE MUST REMAIN WITHIN DIMENSIONS	

DIMENSION STYLE INCH/MM	
DRAWN BY	DATE
RSTONE	2019/03/26
CHECKED BY	DATE
M ZIELIN	----
APPROVED BY	DATE
BWOODMAN	2019/04/18
MATERIAL NO. SEE P/N TABLE	
SIZE	C

SCALE: --- INCH

DESIGN UNITS: INCH

THIRD ANGLE PROJECTION

TITLE: MICRO-CHANGE EXT CORD 5P MA/FE STR A/C 18AWG WITH RED OVERMOLD

MOLEX INCORPORATED

DOCUMENT NO. SD-120066-065

SHEET NO. 1 OF 1

THIS DRAWING CONTAINS INFORMATION THAT IS PROPRIETARY TO MOLEX INCORPORATED AND SHOULD NOT BE USED WITHOUT WRITTEN PERMISSION

**MECHANICAL CHARACTERISTICS:**

TORSIONAL FLEX TEST	10 MILLION CYCLES PER MIL-C-13777G
BEND FLEX TEST	10 MILLION CYCLES PER MIL-C-13777G
WELD SLAG RESISTANCE	WOODHEAD STANDARD S-300

## X-ON Electronics

Largest Supplier of Electrical and Electronic Components

*Click to view similar products for [Sensor Cables / Actuator Cables](#) category:*

*Click to view products by [Molex](#) manufacturer:*

Other Similar products are found below :

[60963](#) [60964](#) [703000D02F2002](#) [703001D02F0602](#) [703001D02F300](#) [704000D02F120](#) [773032K02F030](#) [802027107404-1](#) [802027213811-1](#)  
[804001A09M150](#) [805001A09M0502](#) [84914-0235](#) [84914-0237](#) [885030A09M020](#) [8R4J30E03C3003](#) [1200651332](#) [1200651713](#) [1200660844](#)  
[1200660845](#) [1200661173](#) [1200680071](#) [1200720053](#) [1200720081](#) [1200720099](#) [1200720217](#) [1200800231](#) [1200860125](#) [1200870123](#)  
[1200980102](#) [1200650267](#) [1200650298](#) [1200660183](#) [1200660782](#) [1200660849](#) [1200661295](#) [1200661297](#) [1200661342](#) [1200661343](#)  
[1200670080](#) [1200670220](#) [1200680331](#) [1200720252](#) [1200730184](#) [1200860344](#) [1200870359](#) [1200870643](#) [1200980008](#) [1200980031](#)  
[1210502211](#) [1210400542](#)