

PART MATRIX

**E 1 1 A 0 6 0 1 6 M X X X X**

E = ETHERNET/  
EtherCat

HEADS:  
1=M12 D-Coding  
1=M12 D-Coding

HEADS STYLE:  
060 = MALE STR/MALE STR

CABLE TYPE :

Units:  
M = Meter  
T = 10x Meter

Length  
Examples:  
005 = 0.5 m  
010 = 1 m  
050 = 5 m  
100 = 10 m  
150 = 15 m

H=2 PCS  
ID CARRIER

WIRING TYPE:  
A=4 Pole  
(STRAIGHT WIRED)

WIRING DIAGRAM

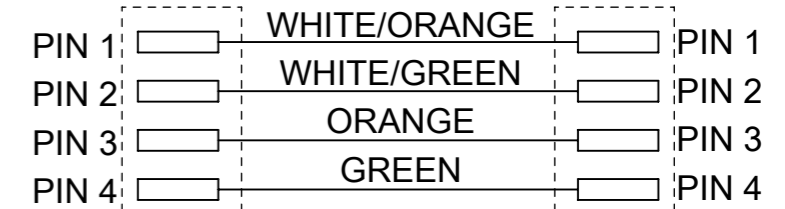

L+Tol. (SEE PART LIST)

SHIELD CONNECTED TO THE HOUSING

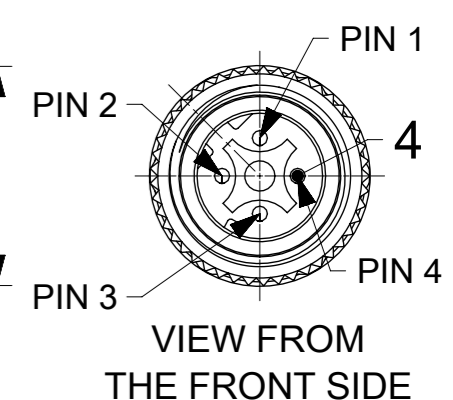
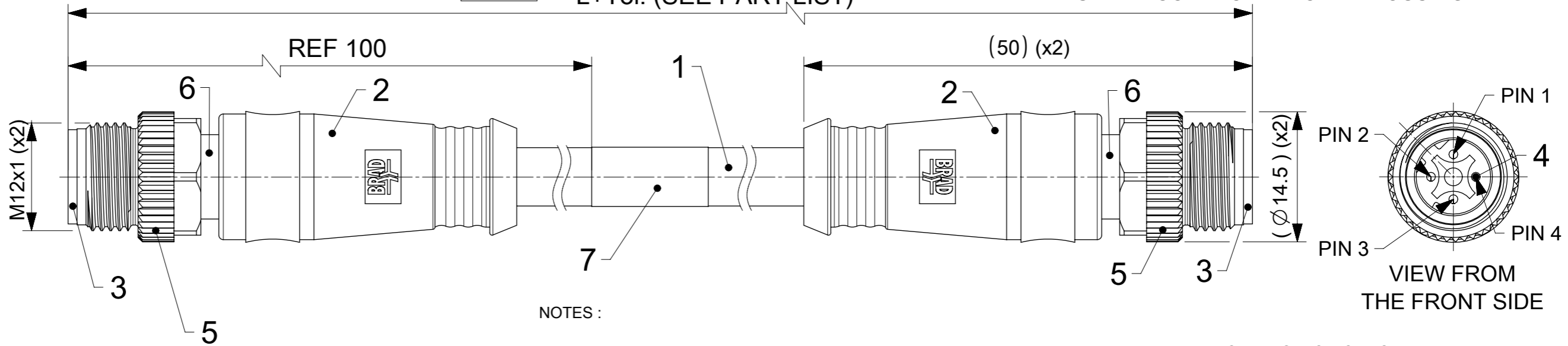
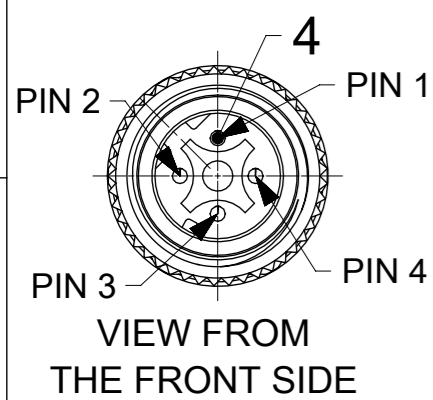

NOTES :

ELECTRICAL DATA :  
VOLTAGE RATING : 30V AC/DC  
AMPERAGE RATING : 1.5A  
INSULATION RESISTANCE : 10<sup>9</sup>Ω MIN.  
MATING CYCLES : MIN. 100

ENVIRONMENTAL :  
PROTECTION : IP67 IN MATED AND LOCKED POSITION  
OPERATING TEMPERATURE : -25°C TO +85°C

TRANSMISSION CHARACTERISTICS ACCORDING TO ISO/IEC 11801 CATEGORY 5e  
PATCH CORD PROFINET TYPE C

CABLE SPECIFICATION  
CONDUCTOR:  
MATERIAL: BARE COPPER  
SECTION: 0.22mm<sup>2</sup> - 24AWG  
INSULATION:  
COMPOUND: PE  
DIAMETER: Ø1.20mm  
COLOR: WHITE/ORANGE, WHITE/GREEN,  
ORANGE, GREEN  
JACKET:  
COMPOUND: TPU  
COLOR: TEAL  
DIAMETER: Ø6.5mm

PART LIST

MOLEX PN	ENGINEERING NO	L+Tol.[mm]
1201088438	E11A06016M380	38000
1201088420	E11A06016M010	1000
1201088421	E11A06016M020	2000
1201088422	E11A06016M030	3000
1201088423	E11A06016M040	4000
1201088424	E11A06016M050	5000
1201088425	E11A06016M060	6000
1201088426	E11A06016M080	8000
1201088427	E11A06016M100	10000
1201088428	E11A06016M120	12000
1201088429	E11A06016M150	15000
1201088430	E11A06016M180	18000
1201088431	E11A06016M200	20000
1201088432	E11A06016M230	23000
1201088433	E11A06016M250	25000
1201088434	E11A06016M270	27000
1201088435	E11A06016M300	30000
1201088436	E11A06016M340	34000
1201088437	E11A06016M350	35000
1201088438	E11A06016M380	38000
1201088439	E11A06016M400	40000
1201088440	E11A06016M450	45000

MOLEX PN	ENGINEERING NO	L+Tol.[mm]
1201088441	E11A06016M500	50000
1201088442	E11A06016M550	55000
1201088443	E11A06016M600	60000
1201088444	E11A06016M650	65000
1201088445	E11A06016M700	70000
1201088446	E11A06016M750	75000
1201088447	E11A06016M760	76000
1201088448	E11A06016M800	80000
1201088449	E11A06016M850	85000
1201088506	E11A06016M070	7000
1201088509	E11A06016M420	42000
1201088510	E11A06016M530	53000
1201088511	E11A06016M570	75000
1201088525	E11A06016M900	90000
1201088585	E11A06016M460	46000
1201088586	E11A06016M540	54000
1201088587	E11A06016M610	61000
1201088588	E11A06016M950	95000
1201088763	E11A06016M680	68000
1201088774	E11A06016M003	300
1201088775	E11A06016M006	600
1201088844	E11A06016M002	200

BOM

ITEM	QTY	DESCRIPTION	MATERIAL	FINISH
7	1	LABEL	VINYL	YELLOW
6	2	M12 SHIELD SLEEVE	BRASS	Ni-PLATED
5	2	NUT M12 MA HEX SW13	BRASS	Ni-PLATED
4	8	CONTACT 10 MA STA	BRASS	SELECTED GOLD OVER NICKEL
3	2	INSERT M12 MA 4P DC	PUR	BLACK
2	-	OVER MOULD	TPU	BLACK
1	-	CABLE #24-2-2 TEAL WELD SLAG RESIST	TPU	TEAL

TABLE 2

CABLE LENGTH TOLERANCES	TOLERANCE
0m-1m	+40 mm
>1m-5m	+60 mm
>5m-10m	+80 mm
>10m-20m	+140 mm
>20m-30m	+160 mm
>30m	+1% length

THIS DRAWING CONTAINS INFORMATION THAT IS PROPRIETARY TO MOLEX ELECTRONIC TECHNOLOGIES, LLC AND SHOULD NOT BE USED WITHOUT WRITTEN PERMISSION

FUNCTIONAL SYMBOLS:  $\nabla/A = 0$ ,  $\nabla/E = 0$ ,  $\nabla/F = 0$

DIVISIONAL SYMBOLS

THIS DRAWING CONTAINS INFORMATION THAT IS PROPRIETARY TO MOLEX ELECTRONIC TECHNOLOGIES, LLC AND SHOULD NOT BE USED WITHOUT WRITTEN PERMISSION

CURRENT REV DESC:

EC NO: 689781  
DRWN: MDHARMANTI 2021/08/03  
CHK'D: RSILLER 2021/12/21  
APPR: RSILLER 2021/12/21

INITIAL REVISION:  
DRWN: MDHARMANTI 2021/08/03  
APPR: RSILLER 2021/12/21

THIRD ANGLE PROJECTION

DRAWING: A3-SIZE  
SERIES: 120108

MATERIAL NUMBER: SEE PART LIST  
CUSTOMER: GENERAL MARKET

SHEET NUMBER: 1 OF 1

DOCUMENT NUMBER: 1201088420  
DOC TYPE: PSD  
DOC PART: 000  
REVISION: A

**molex**

CSE M12 ETH 4P DC MA MA STR WSOR XM DE

PRODUCT CUSTOMER DRAWING

DATE: 2021/12/21 11:53:00

10 9 8 7 6 5 4 3 2 1

MATERIAL NUMBER	ENG. NUMBER	FINISHED LENGTH [M] +TOL [MM]
1201088419	E11A06016M005	0.5 +44 -0
1201088420	E11A06016M010	1.0 +56 -0
1201088433	E11A06016M250	25.0 +622 -0

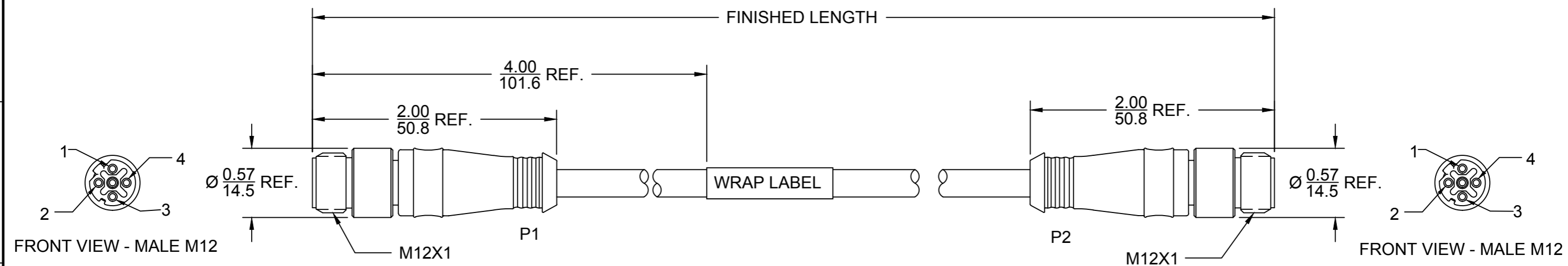

**CABLE TYPE**  
24 AWG PUR-TEAL  
**E11A06016MXXX**

**LENGTH**  
M005 - 0.5M  
M050 - 5M  
M200 - 20M

ADDITIONAL CABLE INFORMATION

PHYSICAL CHARACTERISTICS:	
CONDUCTOR SIZE	24AWG 2 PAIR (19/0.12mm) BARE COPPER
INSULATION MATERIAL	POLYOLEFIN
SHIELD/BRAID	TINNED COPPER 85% COVERAGE
JACKET MATERIAL	PUR (TEAL)
CONDUCTOR	ORANGE, ORANGE-WHITE & GREEN, GREEN-WHITE
TAPE	ALUMINUM-POLYESTER

CABLE:	
TEMPERATURE RATING (STORAGE)	-40 / +80°C
TEMPERATURE RATING (OPERATION)	-20 / +50°C
WELD SLAG RESISTANCE	YES, S-300 MOLEX TEST
FREE SUBSTANCE'S	FCKW, SILICONE, AND PB
FIRE PERFORMANCE	IEC60332-1, UL1581
OIL RESISTANCE	ISO6722, UL758/2556

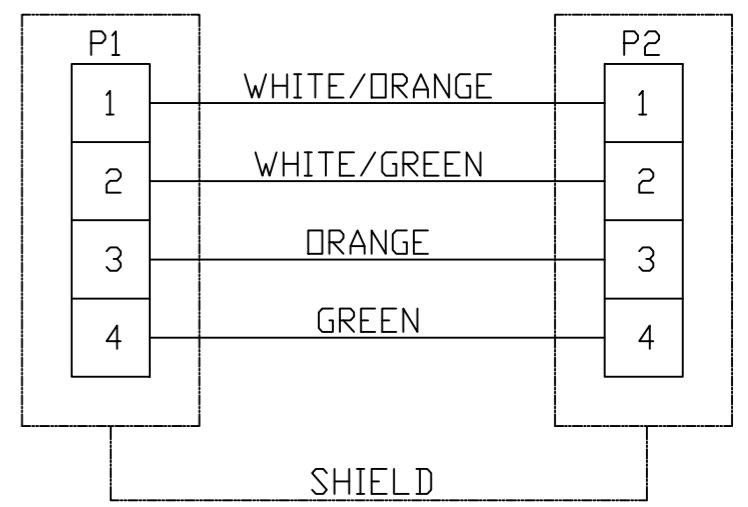

NOTES:  
STANDARDS:  
PROTECTION: IP67  
WRAP LABEL:  
MARKED WITH P/N, DATE CODE, VOLTAGE & AMPERAGE  
ELECTRICAL  
ACCORDING TO CAT5e  
VOLTAGE RATING: 30V AC/DC (B)  
AMPERAGE: 1.5A

QTY	DESCRIPTION	MATERIAL	FINISH
1	LABEL	VINYL	BLACK/YELLOW
2	INSTERT	PUR	BLACK
8	M12 FEMALE PIN CONTACT	COPPER ALLOY	GOLD PLATED
2	M12 COUPLING NUT	BRASS	NICKEL PLATED
2	OVERMOLD	PUR	BLACK
-	CABLE	PUR	TEAL

NOTE CHANGE: 30V WAS 150V  
EC NO: IPG2019-0566  
DRWN: JCAPOZZ 2019/06/24  
CHKD: ---  
APPR: BWOODMAN2015/06/03

QUALITY SYMBOLS	GENERAL TOLERANCES (UNLESS SPECIFIED)
▽=0	mm INCH
▽C=0	4 PLACES ±--- ±---
	3 PLACES ±--- ±.005
	2 PLACES ±0.05 ±.010
	1 PLACE ±0.10 ±.020
	ANGULAR ±.5°
	DRAFT WHERE APPLICABLE MUST REMAIN WITHIN DIMENSIONS

DIMENSION STYLE	
INCH/MM	
DRAWN BY	DATE
MZIELINS	2015/05/06
CHECKED BY	DATE
BARDEN	2015/06/04
APPROVED BY	DATE
BWOODMAN	2015/06/03
MATERIAL NO.	SEE MATRIX

SCALE	DESIGN UNITS	THIRD ANGLE PROJECTION
NTS	INCH	☉
TITLE		
MICRO-CHANGE 4P MALE/MALE M12 ST/ST #24-2TP TEAL PUR CAT5E		
MOLEX MOLEX INCORPORATED		SHEET NO.
DOCUMENT NO. SD-120108-083		1 OF 1
THIS DRAWING CONTAINS INFORMATION THAT IS PROPRIETARY TO MOLEX INCORPORATED AND SHOULD NOT BE USED WITHOUT WRITTEN PERMISSION		

10 9 8 7 6 5 4 3 2 1

## X-ON Electronics

Largest Supplier of Electrical and Electronic Components

*Click to view similar products for [Sensor Cables / Actuator Cables](#) category:*

*Click to view products by [Molex](#) manufacturer:*

Other Similar products are found below :

[60963](#) [60964](#) [703000D02F2002](#) [703001D02F0602](#) [703001D02F300](#) [704000D02F120](#) [773032K02F030](#) [802027107404-1](#) [802027213811-1](#)  
[804001A09M150](#) [805001A09M0502](#) [84914-0235](#) [84914-0237](#) [885030A09M020](#) [8R4J30E03C3003](#) [1200651332](#) [1200651713](#) [1200660844](#)  
[1200660845](#) [1200661173](#) [1200680071](#) [1200720053](#) [1200720081](#) [1200720099](#) [1200720217](#) [1200800231](#) [1200860125](#) [1200870123](#)  
[1200980102](#) [1200650267](#) [1200650298](#) [1200660183](#) [1200660782](#) [1200660849](#) [1200661295](#) [1200661297](#) [1200661342](#) [1200661343](#)  
[1200670080](#) [1200670220](#) [1200680331](#) [1200720252](#) [1200730184](#) [1200860344](#) [1200870359](#) [1200870643](#) [1200980008](#) [1200980031](#)  
[1210502211](#) [1210400542](#)