

| PART NO. | ENGINEERING NO. | FINISHED LENGTH |
|------------|-----------------|------------------------------|
| 1300102070 | 113030K13M005 | 0.5M+44.5mm-0 [1'8"+1.75"-0] |
| 1300100487 | 113030K13M010 | 1.0M+55.6mm-0 [3'3"+2.19"-0] |
| 1300100488 | 113030K13M020 | 2.0M+88.9mm-0 [6'7"+3.50"-0] |

CHART

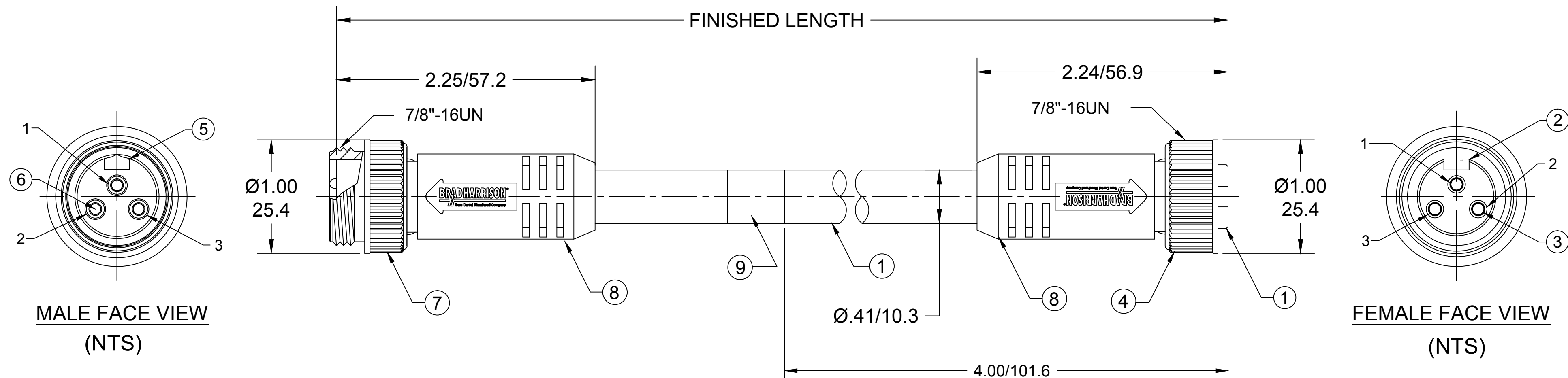

NOTES:

- 1. MATERIAL: SEE TABLE
- 2. FINISH: SEE TABLE
- 3. ELECTRICAL:
VOLTAGE: 500V PER IEC 60664
600V PER UL 2238
CURRENT: 13A
- 4. TEMP RATING: -40°TO +90°C ^(D)
- 5. PROTECTION: IP67 (WHEN MATED)
- 6. UL CERTIFICATION: UL LISTED, FILE NO. E152210
- 7. ALL DIMS ARE FOR REFERENCE
UNLESS NOTED OTHERWISE

113030K13M010 ^(D)

cable length

M005= 0.5 METER
M010= 1.0 METER
M100= 10.0 METER

| | | |
|---|--------------|---|
| 1 | GREEN-YELLOW | 1 |
| 2 | BLACK | 2 |
| 3 | WHITE | 3 |

WIRING DIAGRAM

| CABLE LENGTH TOLERANCES | |
|--------------------------|-------------------------|
| >.3M [1FT]: | +19mm-0 [+ .75in-0] |
| .3 - .9M [1 - 3FT]: | +44.5mm-0 [+1.75in-0] |
| .9 - 1.8M [3 - 6FT]: | +55.6mm-0 [+2.19in-0] |
| 1.8 - 3.7M [6 - 12FT]: | +88.9mm-0 [+3.50in-0] |
| 3.7 - 7.3M [12 - 24FT]: | +165.1mm-0 [+6.50in-0] |
| 7.3-14.6M [24 - 48FT]: | +317.5mm-0 [+12.50in-0] |
| 14.6 - 30.5M [48-100FT]: | +622.3mm-0 [+24.50in-0] |
| OVER 30M [100FT] | +2% OF FINISHED LENGTH |

MECHANICAL CHARACTERISTICS:

| | |
|----------------------|------------------------------------|
| TORSIONAL FLEX TEST | 20 MILLION CYCLES PER MIL-C-13777G |
| BEND FLEX TEST | 20 MILLION CYCLES PER MIL-C-13777G |
| WELD SLAG RESISTANCE | WOODHEAD STANDARD S-300 |

| ITEM | DESCRIPTION | MATERIAL | FINISH |
|------|-----------------------------|---------------|--------------|
| 9 | WRAP LABEL | VINYL | BLACK/YELLOW |
| 8 | OVERMOLD | ARNITEL | YELLOW |
| 7 | COUPLING, MALE | ZINC DIE-CAST | BLACK |
| 6 | CONTACT PIN | COPPER ALLOY | GOLD PLATED |
| 5 | MALE INSERT (A-SIZE) | ARNITEL | YELLOW |
| 4 | COUPLING, FEMALE | ZINC DIE-CAST | BLACK |
| 3 | CONTACT SOCKET | COPPER ALLOY | GOLD PLATED |
| 2 | FEMALE INSERT (A-SIZE) | ARNITEL | YELLOW |
| 1 | CABLE, 16/3 TC-ER (HI-FLEX) | TPE JACKET | YELLOW |

| | | | | | | |
|--------------------|----------------|---------------------------------------|---------------------|---|--|------------------------|
| REV DESCRIPTION | QUALITY SYMBOL | GENERAL TOLERANCES (UNLESS SPECIFIED) | DIMENSION STYLE | SCALE | DESIGN UNITS | THIRD ANGLE PROJECTION |
| | ▼=0 | mm INCH | IN/MM | NTS | INCH | |
| | ▽=0 | 4 PLACES ±--- ±--- | DRAWN BY DATE | TITLE | MINI-CHANGE CORDSET 3 POLE MALE/FEMALE TPE CABLE | |
| | | 3 PLACES ±--- ±--- | BARDEN 2015/08/12 | | | |
| | | 2 PLACES ±--- ±--- | CHECKED BY DATE | | | |
| | | 1 PLACE ±--- ±--- | TWOLDEGE 2009/03/27 | | | |
| | | | APPROVED BY DATE | | | |
| | | | JFMURPHY 2015/08/12 | | | |
| | | | MATERIAL NO. | DOCUMENT NO. | SHEET NO. | |
| | | | SEE MATRIX | SD-130010-001 | 1 OF 1 | |
| | | | SIZE C | THIS DRAWING CONTAINS INFORMATION THAT IS PROPRIETARY TO MOLEX INCORPORATED AND SHOULD NOT BE USED WITHOUT WRITTEN PERMISSION | | |

X-ON Electronics

Largest Supplier of Electrical and Electronic Components

Click to view similar products for [D-Sub Micro-D Connectors](#) category:

Click to view products by [Molex](#) manufacturer:

Other Similar products are found below :

[003626](#) [025-1227-000](#) [0685610016](#) [0688014147](#) [0688014227](#) [07190-SP036](#) [0745461602](#) [0751341000](#) [0795762102](#) [0797580009](#)
[0834249014](#) [0836129020](#) [0836129024](#) [0836199011](#) [0887329200](#) [0897613412](#) [0923150410](#) [0923150615](#) [0923151609](#) [0923171036](#) [094-](#)
[0116-2007](#) [094-6135-0000](#) [094-6136-0000](#) [094-6235-0000](#) [094-6335-0000](#) [094-6435-0000](#) [094-6535-0000](#) [094-6635-0000](#) [094-6636-0000](#)
[094-6735-0000](#) [094-6935-0000](#) [094-6936-0000](#) [095-0605-2053](#) [095-0607-2055](#) [095479-0007](#) [095480-0011](#) [096510-0306](#) [09651226803](#)
[096513-0002](#) [096516-0222](#) [098-9027-0029](#) [10090930-P150ALF](#) [100RC21SCBR1](#) [100RC31SCBRP2](#) [100RC37PC6P1](#) [100RN31P-C6PT2](#)
[10114-3000PE](#) [10114-6000EC](#) [10114-6000EL](#) [10120-3000PE](#)