

PART NO	ENGINEERING NO.	FINISHED LENGTH
1300100971	114033K03M002	0.2M [8 IN]
1300102071	114033K03M100	10M [32FT 10 IN]
1300100981	114033K03M250	25M [82FT]

- NOTES:
- MATERIAL: AS NOTED
 - FINISH: AS NOTED
 - ELECTRICAL:
VOLTAGE: 300V AC/DC
CURRENT: 5.6A
 - TEMP RATING: -20°C TO +105°C
 - PROTECTION: IP67 (WHEN MATED)
 - COUPLING THREAD: 7/8-16UN
 - CABLE BEND RADIUS IS 10X CABLE DIA.
 - CSA LISTED FILE: LR6837
 - ALL DIMENSIONS ARE FOR REFERENCE UNLESS TOLERANCED OR NOTED OTHERWISE

MECHANICAL CHARACTERISTICS:

TORSIONAL FLEX TEST	10 MILLION CYCLES PER MIL-C-13777G
BEND FLEX TEST	10 MILLION CYCLES PER MIL-C-13777G
WELD SLAG RESISTANCE	WOODHEAD STANDARD S-300

ITEM	DESCRIPTION	MATERIAL	FINISH
10	WRAP LABEL	VINYL	BLACK/YELLOW
9	FRICITION RING	NYLON	NATURAL
8	COUPLING NUT, MALE THREAD	ZINC DIE-CAST	BLACK E-COAT
7	CONTACT PIN	COPPER ALLOY	GOLD PLATED
6	MALE INSERT	TPE	YELLOW
5	OVERMOLD	TPE	YELLOW
4	COUPLING NUT, FEMALE THREAD	ZINC DIE-CAST	BLACK E-COAT
3	CONTACT SOCKET	COPPER ALLOY	GOLD PLATED
2	FEMALE INSERT	TPE	YELLOW
1	CABLE, 18 AWG ITC/PLTC, HI-FLEX	TPE JACKET	YELLOW

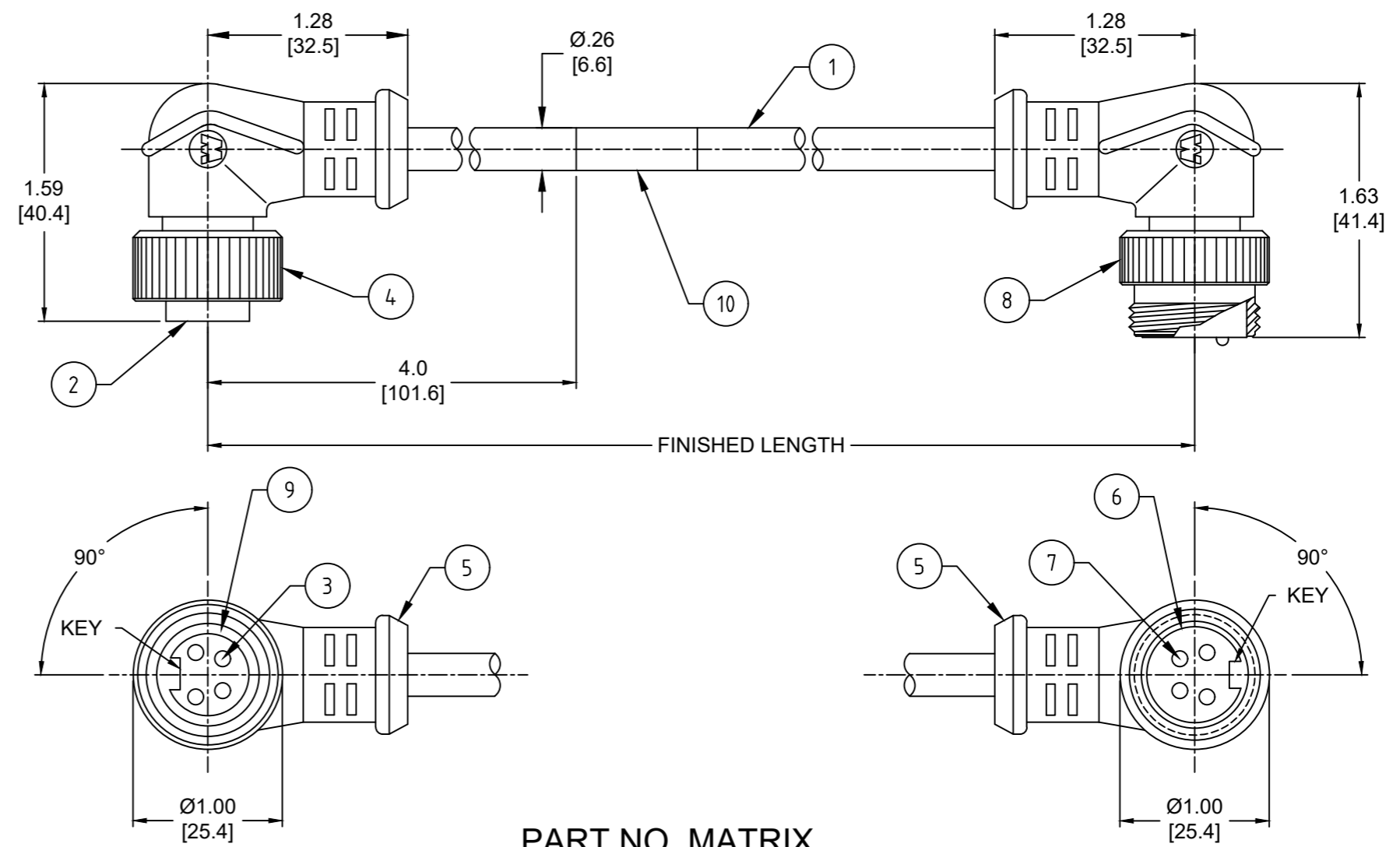

PART NO. MATRIX
114033K03M002

FINISHED LENGTH:
M002= 0.2 METER
M010= 1 METER
M100= 10 METER

CABLE LENGTH TOLERANCES

<.3M [1FT]:	+19mm-0 [+1.75in-0]
.3 - .9M [1 - 3FT]:	+44.5mm-0 [+1.75in-0]
.9 - 1.8M [3 - 6FT]:	+55.6mm-0 [+2.19in-0]
1.8 - 3.7M [6 - 12FT]:	+88.9mm-0 [+3.50in-0]
3.7 - 7.3M [12 - 24FT]:	+165.1mm-0 [+6.50in-0]
7.3-14.6M [24 - 48FT]:	+317.5mm-0 [+12.50in-0]
14.6 - 30.5M [48-100FT]:	+622.3mm-0 [+24.50in-0]
OVER 30M [100FT]	+2% OF FINISHED LENGTH

FUNCTIONAL SYMBOLS $F=0$ $E=0$ $P=0$	THIS DRAWING CONTAINS INFORMATION THAT IS PROPRIETARY TO MOLEX ELECTRONIC TECHNOLOGIES, LLC AND SHOULD NOT BE USED WITHOUT WRITTEN PERMISSION		CURRENT REV DESC: ITEM# 2, 5 & 6 WERE PVC. ADDED ITEM #9, TOL CHART & MECH CHART... MODIFIED TEMP RATING & MATERIAL NUMBER CHART		
	DIMENSION UNITS INCH/MM	SCALE NTS	GENERAL TOLERANCES (UNLESS SPECIFIED)		
	4 PLACES ±--- ±---	mm INCH	EC NO: 663067 DRWN: ABENJAMINLW 2021/01/18 CHK'D: RSTONE 2021/05/06 APPR: BWOODMAN 2021/05/13		
	3 PLACES ±--- ±---	DIVISIONAL SYMBOLS	INITIAL REVISION: DRWN: RSTONE 2017/02/23 APPR: BWOODMAN 2017/03/08		
2 PLACES ±--- ±---	DRAFT WHERE APPLICABLE MUST REMAIN WITHIN DIMENSIONS	THIRD ANGLE PROJECTION	DRAWING B-SIZE	SERIES 130010	
1 PLACE ±--- ±---	0 PLACES ±--- ±---	MATERIAL NUMBER SEE CHART	CUSTOMER GENERAL MARKET	SHEET NUMBER 1 OF 1	
DOCUMENT STATUS P1 RELEASE DATE 2021/05/13 00:30:13		DOCUMENT NUMBER SD-130010-039			
FORMAT: IN-ACAD-IB-prod-B REVISION: B DATE: 2020/01/14		DOC TYPE/DOC PART/REVISION PSD 001 B			

X-ON Electronics

Largest Supplier of Electrical and Electronic Components

Click to view similar products for [Sensor Cables / Actuator Cables](#) category:

Click to view products by [Molex](#) manufacturer:

Other Similar products are found below :

[60963](#) [60964](#) [M83513/19-F01CP](#) [703000D02F2002](#) [703001D02F0602](#) [703001D02F300](#) [704000D02F120](#) [773032K02F030](#) [802027107404-1](#)
[802027213811-1](#) [804001A09M150](#) [805001A09M0502](#) [84914-0235](#) [84914-0237](#) [885030A09M020](#) [8R4J30E03C3003](#) [1200651332](#)
[1200651713](#) [1200660844](#) [1200660845](#) [1200661173](#) [1200680071](#) [1200720053](#) [1200720081](#) [1200720099](#) [1200720217](#) [1200800231](#)
[1200860125](#) [1200870123](#) [1200980102](#) [1200650267](#) [1200650298](#) [1200660183](#) [1200660782](#) [1200660849](#) [1200661295](#) [1200661297](#)
[1200661342](#) [1200661343](#) [1200670080](#) [1200670220](#) [1200680331](#) [1200720252](#) [1200730184](#) [1200860344](#) [1200870359](#) [1200870643](#)
[1200980008](#) [1200980031](#) [1210502211](#)