

PRODUCT SPECIFICATION:

- 1. ELECTRICAL:
VOLTAGE: 250V AC/DC
CURRENT: 4A
- 4. TEMP RATING: -20° TO +80°C
- 5. PROTECTION: IP67 (WHET MATED)
- 6. AGENCY:
UL LISTED, FILE: E152210
CSA CERTIFICATION FILE: LR6837

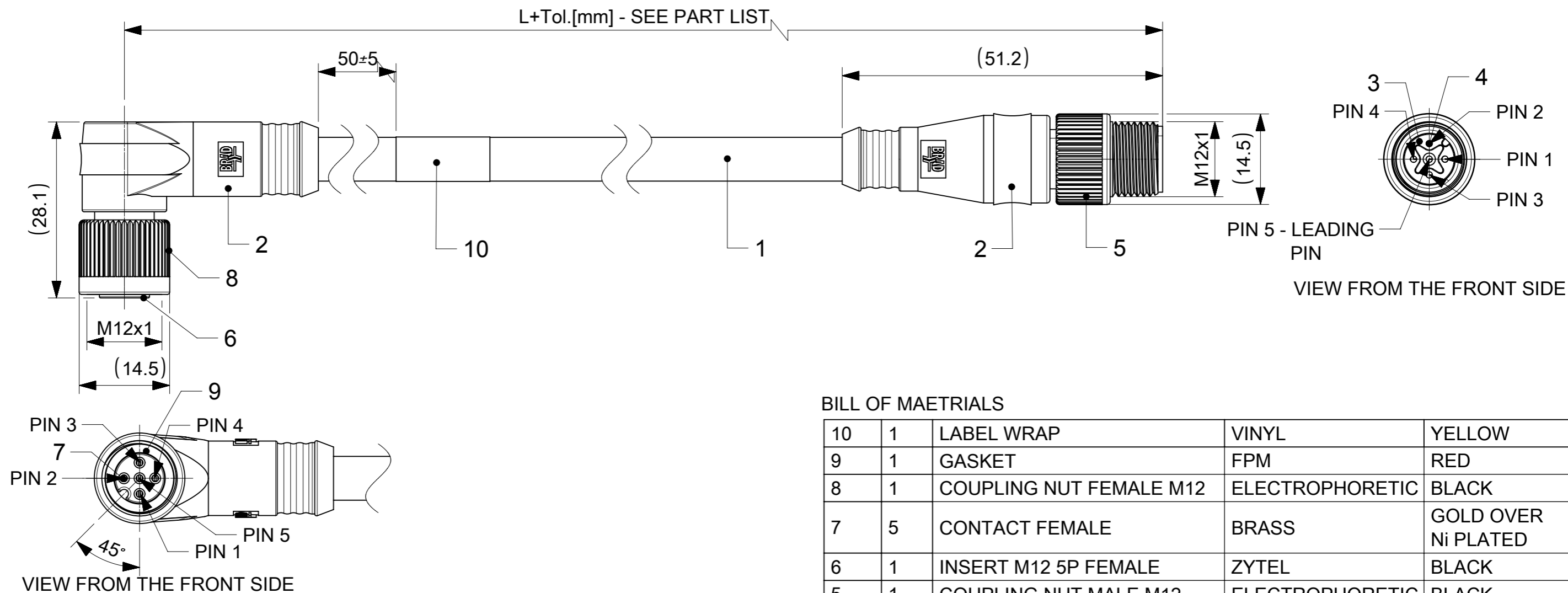
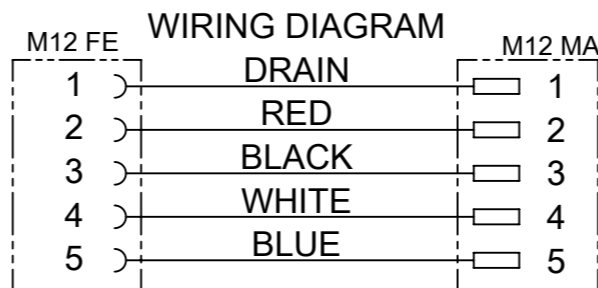

BILL OF MAETRIALS

ITEM	QTY	DESCRIPTION	MATERIAL	FINISH/COLOR
10	1	LABEL WRAP	VINYL	YELLOW
9	1	GASKET	FPM	RED
8	1	COUPLING NUT FEMALE M12	ELECTROPHORETIC	BLACK
7	5	CONTACT FEMALE	BRASS	GOLD OVER Ni PLATED
6	1	INSERT M12 5P FEMALE	ZYTEL	BLACK
5	1	COUPLING NUT MALE M12	ELECTROPHORETIC	BLACK
4	5	CONTACT MALE	BRASS	GOLD OVER Ni PLATED
3	1	INSERT M12 5P MA AC	ZYTEL	BLACK
2	-	MOULDING MATERIAL	PVC	GRAY
1	-	DROP CABLE 4x0.34mm ²	PVC	GRAY

PART LIST

MOLEX PN	ENGINEERING NO	L+Tol.[mm]
1300280003	DND32A-M006	600 +45
1300280080	DND32A-M002	200 +19
1300280081	DND32A-M003	300 +19
1300280082	DND32A-M004	400 +45
1300280083	DND32A-M005	500 +45
1300280084	DND32A-M007	700 +45
1300280085	DND32A-M010	1000 +56
1300280086	DND32A-M015	1500 +56
1300280089	DND32A-M030	3000 +89
1300280091	DND32A-M050	5000 +165

<p>SYMBOLS</p> <p>▽ = 0 DIMENSION UNITS</p> <p>▽ = 0 SCALE</p> <p>▽ = 0 GENERAL TOLERANCES (UNLESS SPECIFIED)</p> <p>▽ = 0 ANGULAR TOL ± 1.0°</p> <p>▽ = 0 4 PLACES ±</p> <p>▽ = 0 3 PLACES ±</p> <p>▽ = 0 2 PLACES ± 0.05</p> <p>▽ = 0 1 PLACE ± 0.3</p> <p>▽ = 0 0 PLACES ± 0.5</p> <p>■ = 0 DRAFT WHERE APPLICABLE MUST REMAIN WITHIN DIMENSIONS</p>	<p>mm</p> <p>1.5:1</p>	<p>CURRENT REV DESC:</p> <p>EC NO: 618920</p> <p>DRWN: MKOWALCZYK01 2019/06/11</p> <p>CHK'D: DSTACHOWIAK 2019/06/12</p> <p>APPR: DSTACHOWIAK 2019/06/12</p> <p>INITIAL REVISION:</p> <p>DRWN: MKOWALCZYK01 2018/10/09</p> <p>APPR: MIWASIECZKO 2018/10/12</p>	<p>molex</p> <p>MIC 5P M/FE XM 90/ST DROP</p> <p>PRODUCT CUSTOMER DRAWING</p>
	<p>DOCUMENT NUMBER</p> <p>1300280080</p>	<p>DOC TYPE</p> <p>PSD</p>	<p>DOC PART</p> <p>000</p>
<p>THIRD ANGLE PROJECTION</p> <p>DRAWING</p> <p>A3-SIZE</p>	<p>SERIES</p> <p>130028</p>	<p>MATERIAL NUMBER</p> <p>SEE PART LIST</p>	<p>CUSTOMER</p> <p>GENERAL MARKET</p>
		<p>SHEET NUMBER</p> <p>1 OF 1</p>	

PART NUMBER	ENGINEERING NO.	LENGTH ± TOLERANCE
1300280083	DND32A-M005	1' 8" +1.75"/-0" [0.5M +44.5/-0 mm]
1300280084	DND32A-M007	2' 4" +1.75"/-0" [0.7M +44.5/-0 mm]
1300280085	DND32A-M010	3' 3" +2.19"/-0" [1M +55.6/-0 mm]
1300280089	DND32A-M030	9' 10" +3.50"/-0" [3M +88.9/-0 mm]
1300280091	DND32A-M050	16' 5" +6.50"/-0" [5M +165.1/-0 mm]

AUX VIEW
SCALE 1:4

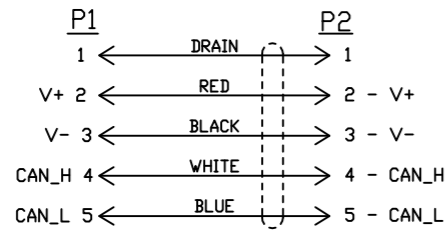
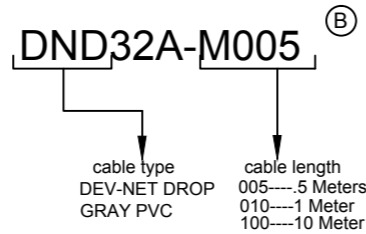
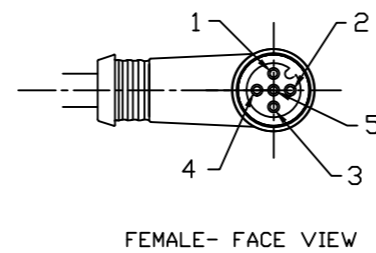
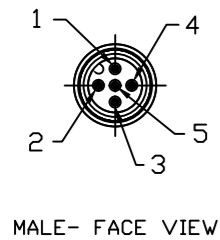
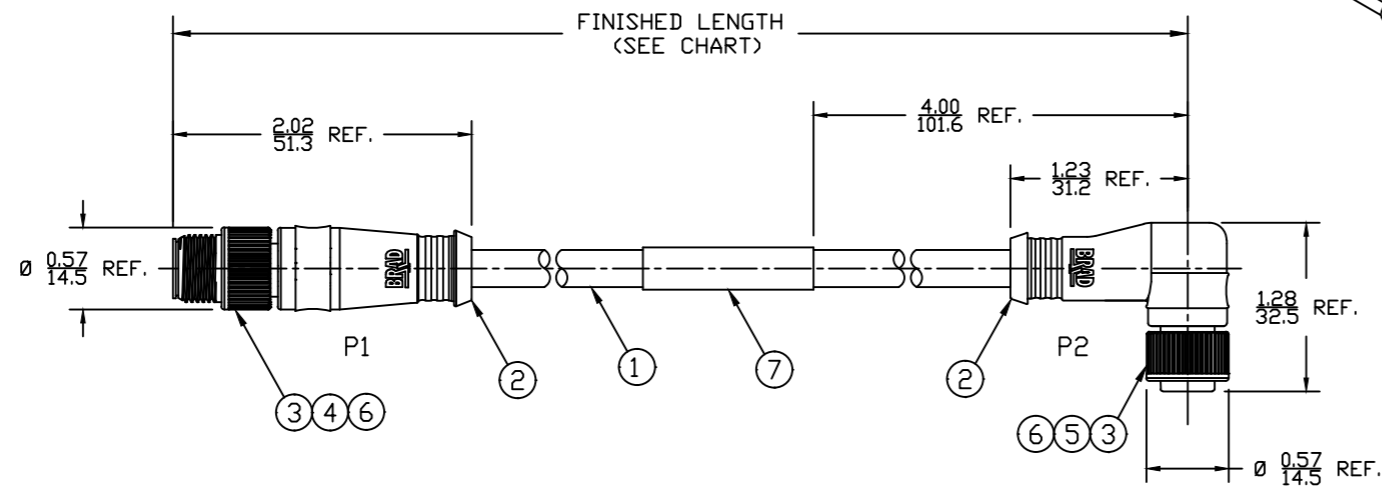

NOTES:

- MATERIAL: SEE TABLE
- FINISHES: SEE TABLE
- ELECTRICAL DATA:
MAX. VOLTAGE: 250V AC/DC
MAX. CURRENT: 4A
- ENVIRONMENTAL:
PROTECTION: IP67 (WHEN MATED)
TEMPERATURE RANGE: -20°C TO 80°C
- WRAP LABEL IS MARKED WITH P/N, DATE CODE, VOLTAGE & AMPERAGE.
- DIMS SHOWN ARE FOR REFERENCE UNLESS NOTED OTHERWISE

TABLE

ITEM	DESCRIPTION	MATERIAL	FINISH
7	LABEL	VINYL	BLACK/YELLOW
6	INSERT	NYLON	BLACK
5	SOCKET CONTACT	COPPER ALLOY	GOLD PLATED
4	PIN CONTACT	COPPER ALLOY	GOLD PLATED
3	M12 COUPLING NUT	ZINC DIE-CAST	BLACK
2	OVERMOLD	PVC	GRAY
1	DEVICENET DROP CABLE, 2P, SHLD	PVC JACKET	GRAY

CORRECTED PINS FOR .5 & .7M
EC NO: IPG2017-0356
DRWN: RSTONE 10/3/16
CHKD: M ZIELIN 2016/10/04
APPR: TWOLDEGE

QUALITY SYMBOLS	GENERAL TOLERANCES (UNLESS SPECIFIED)		DIMENSION STYLE	SCALE	DESIGN UNITS	THIRD ANGLE PROJECTION
	mm	INCH	IN/MM	---	INCH	
▽=0	4 PLACES	±---	DRAWN BY	DATE	TITLE	M12 DEVICENET CABLE ASSY 5P MALE/FEM ST/90 #22/4 SHLD PVC -THIN STD MOLEX INCORPORATED
▽C=0	3 PLACES	±---	CHECKED BY	DATE		
	2 PLACES	±---	BWOODMAN	2009/07/31		
	1 PLACE	±---	APPROVED BY	DATE		
	ANGULAR ±---°		MATERIAL NO.	DOCUMENT NO.	SHEET NO.	
DRAFT WHERE APPLICABLE MUST REMAIN WITHIN DIMENSIONS			SEE CHART		SD-130028-002	1 OF 1
SIZE A THIS DRAWING CONTAINS INFORMATION THAT IS PROPRIETARY TO MOLEX INCORPORATED AND SHOULD NOT BE USED WITHOUT WRITTEN PERMISSION						

X-ON Electronics

Largest Supplier of Electrical and Electronic Components

Click to view similar products for [Sensor Cables / Actuator Cables](#) category:

Click to view products by [Molex](#) manufacturer:

Other Similar products are found below :

[1300070444](#) [43-10984](#) [M83513/19-F01CP](#) [704000D02F120](#) [MDM15SH001K](#) [MDM25PH003BF222](#) [802027107404-1](#) [885030A09M010](#)
[885030A09M020](#) [1200650174](#) [1200651332](#) [1200651713](#) [1200660171](#) [1200660208](#) [1200660343](#) [1200660804](#) [1200660845](#) [1200660926](#)
[1200660977](#) [1200661173](#) [1200661354](#) [120066-1712](#) [1200720053](#) [1200720099](#) [1200720153](#) [1200720172](#) [1200720217](#) [1200720226](#)
[1200720251](#) [1200720285](#) [1200720296](#) [1200720404](#) [1200730148](#) [1200730378](#) [1200800231](#) [1200860112](#) [1200860121](#) [1200860125](#)
[1200860337](#) [1200860365](#) [1200860420](#) [1200870046](#) [1200870123](#) [1200870248](#) [1200980102](#) [1200660181](#) [1200660183](#) [1200660827](#)
[1200660849](#) [1200661170](#)