

PART NO	ENGINEERING NO.	FINISHED LENGTH
1300660235	CR4000A76M005	0.5M [1FT 7 IN]
1300660231	CR4000A76M030	3M [9FT 10 IN]
1300662012	CR4000A76M050	5M [16FT 5 IN]

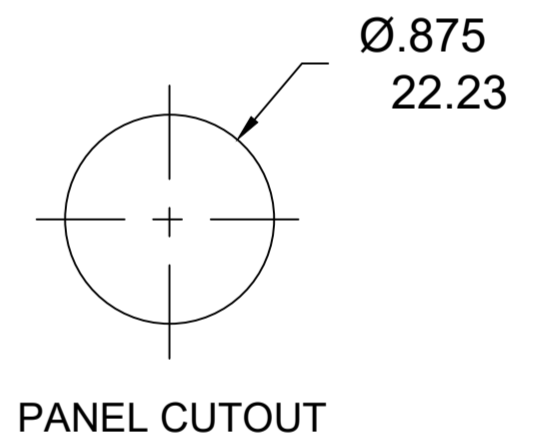
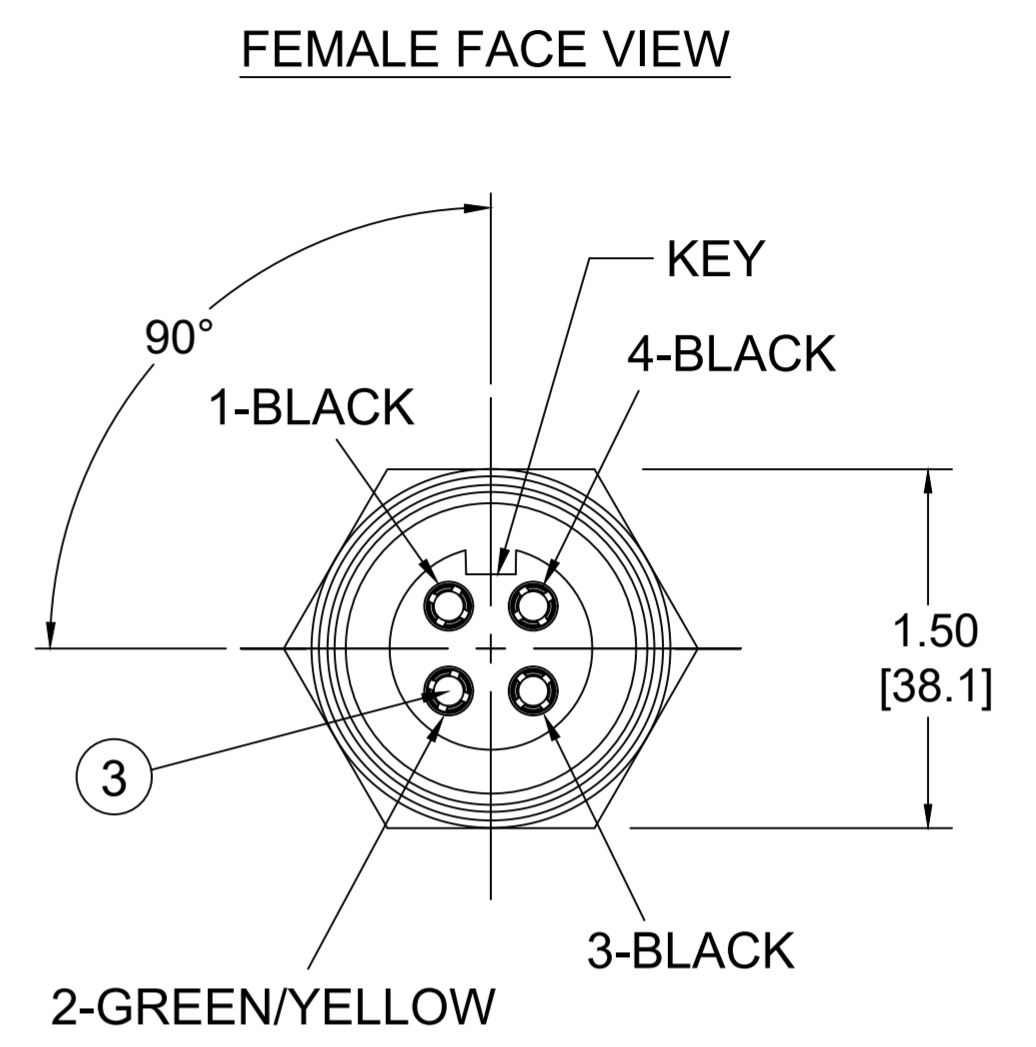
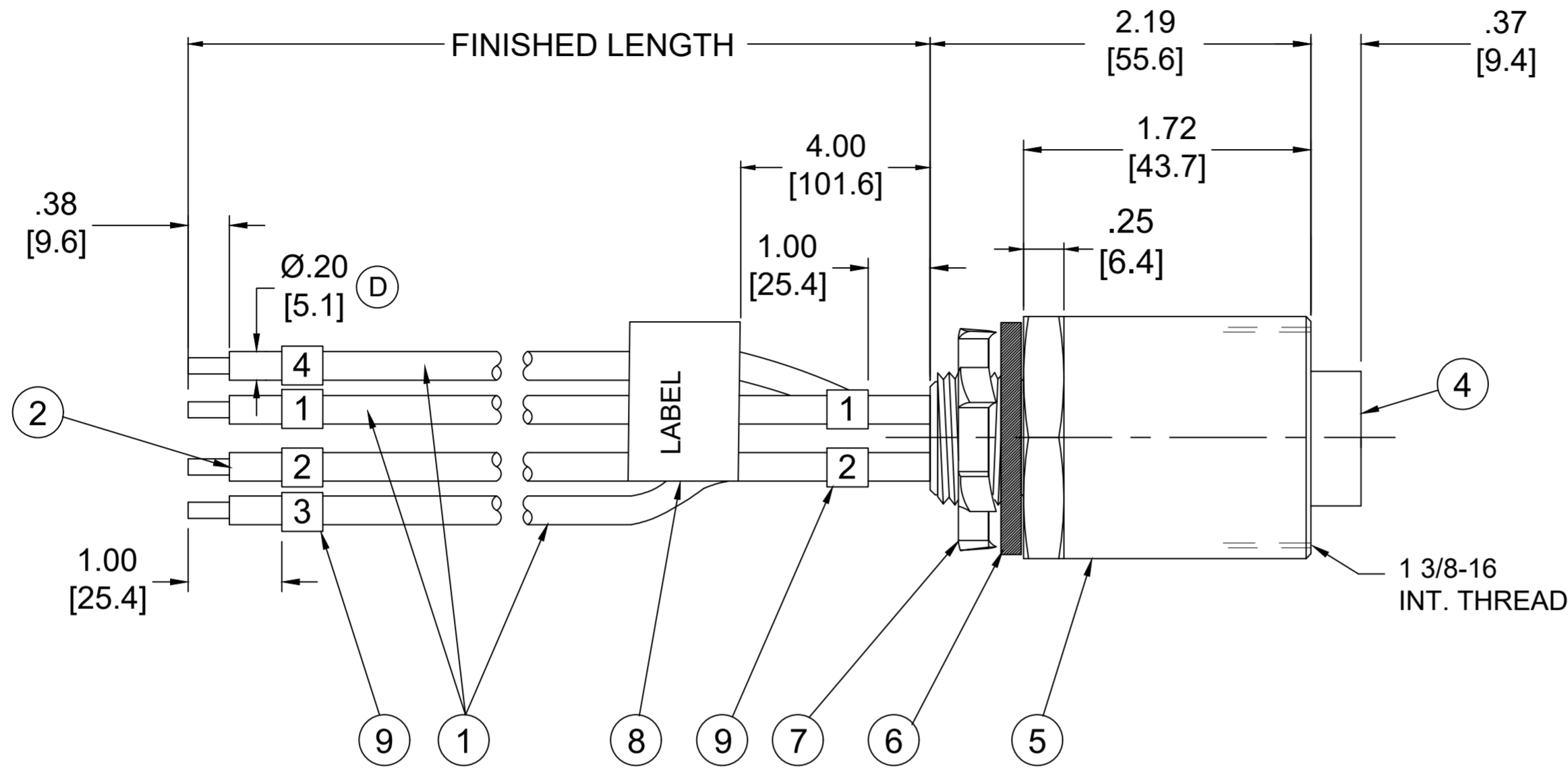

- NOTES:
1. MATERIAL: AS NOTED
 2. FINISH: AS NOTED
 3. ELECTRICAL:
VOLTAGE: 500V PER IEC60664
600V AC/DC PER UL2237
CURRENT: 32A
 4. WIRE ID LABELS INDICATE PIN NUMBER
 5. PROTECTION: IP67 (WHEN MATED)
 6. TEMP RATING: -20°C TO +105°C (D)
 7. PANEL THICKNESS: .12 (3mm)
 8. UL LISTED FILE: E258922
 9. ALL DIMENSIONS ARE FOR REFERENCE
UNLESS TOLERANCED OR NOTED OTHERWISE

PART NO. MATRIX
CR4000A76M010

FINISHED LENGTH:
M005= 0.5 METER
M010= 1 METER
M100= 10 METER

CABLE LENGTH TOLERANCES

<.3M [1FT]:	+19mm-0 [+ .75in-0]
.3 - .9M [1 - 3FT]:	+44.5mm-0 [+1.75in-0]
.9 - 1.8M [3 - 6FT]:	+55.6mm-0 [+2.19in-0]
1.8 - 3.7M [6 - 12FT]:	+88.9mm-0 [+3.50in-0]
3.7 - 7.3M [12 - 24FT]:	+165.1mm-0 [+6.50in-0]
7.3-14.6M [24 - 48FT]:	+317.5mm-0 [+12.50in-0]
14.6 - 30.5M [48-100FT]:	+622.3mm-0 [+24.50in-0]
OVER 30M [100FT]	+2% OF FINISHED LENGTH

ITEM	DESCRIPTION	MATERIAL	FINISH
9	WIRE IDENTIFIER LABEL	VINYL	BLACK ON WHITE
8	FLAG LABEL	VINYL	YELLOW
7	LOCKNUT, 1/2 NPT	STEEL	ZINC PLATE
6	GASKET	NEOPRENE	BLACK
5	RECEPTACLE SHELL	6061-T6 ALUMINUM	CLEAR ANOIZED
4	FEMALE INSERT	TPE	BLACK
3	CONTACT SOCKET	COPPER ALLOY	GOLD PLATED
2	#10-1 WIRE UL 1015	PVC JACKET	GREEN/YELLOW
1	#10-1 WIRE UL 1015	PVC JACKET	BLACK
ITEM	DESCRIPTION	MATERIAL	FINISH

FUNCTIONAL SYMBOLS FA=0 FC=0 FP=0	DIMENSION UNITS	SCALE	CURRENT REV DESC: ITEM #4 WAS PVC. UPDATED TEMP RATING. ADDED KEY ANGLE & CABLE DIA. MODIFIED MATERIAL NUMBER CHART	
	INCH/MM	NTS		
	GENERAL TOLERANCES (UNLESS SPECIFIED)			
	mm		INCH	
DIVISIONAL SYMBOLS	4 PLACES	±----	±----	EC NO: 663067
	3 PLACES	±----	±----	DRWN: ABENJAMINLW 2021/01/07
	2 PLACES	±----	±----	CHK'D: RSTONE 2021/05/06
	1 PLACE	±----	±----	APPR: BWOODMAN 2021/05/13
0 PLACES		±----	±----	INITIAL REVISION:
ANGULAR TOL ± ---- °		DRWN: MODELL 2008/04/28		
DRAFT WHERE APPLICABLE MUST REMAIN WITHIN DIMENSIONS		APPR: JFMURPHY 2008/05/22		
THIRD ANGLE PROJECTION		DRAWING	SERIES	DOCUMENT NUMBER
C-SIZE		130066	SD-130066-005	PSD 001 D
MATERIAL NUMBER		CUSTOMER	SHEET NUMBER	
SEE CHART		GM	1 OF 1	

X-ON Electronics

Largest Supplier of Electrical and Electronic Components

Click to view similar products for [Sensor Cables / Actuator Cables](#) category:

Click to view products by [Molex](#) manufacturer:

Other Similar products are found below :

[60963](#) [60964](#) [703000D02F2002](#) [703001D02F0602](#) [703001D02F300](#) [704000D02F120](#) [773032K02F030](#) [802027107404-1](#) [802027213811-1](#)
[804001A09M150](#) [805001A09M0502](#) [84914-0235](#) [84914-0237](#) [885030A09M020](#) [8R4J30E03C3003](#) [1200651332](#) [1200651713](#) [1200660844](#)
[1200660845](#) [1200661173](#) [1200680071](#) [1200720053](#) [1200720081](#) [1200720099](#) [1200720217](#) [1200800231](#) [1200860125](#) [1200870123](#)
[1200980102](#) [1200650267](#) [1200650298](#) [1200660183](#) [1200660782](#) [1200660849](#) [1200661295](#) [1200661297](#) [1200661342](#) [1200661343](#)
[1200670080](#) [1200670220](#) [1200680331](#) [1200720252](#) [1200730184](#) [1200860344](#) [1200870359](#) [1200870643](#) [1200980008](#) [1200980031](#)
[1210502211](#) [1210400542](#)