

- GENERAL NOTES: (UNLESS OTHERWISE SPECIFIED)
- MATING TERMINAL SHOWN ON SD-33012-002
 - MATERIAL: ASTM B422, UNS C19025, HR04
THICKNESS: 0.30 mm ±0.01
TEMPER: FULL HARD (REF)
TENSILE: 496-572 MPA
 - TIN PLATED TERMINAL FINISH:
OVERALL UNDERPLATE ELECTRODEPOSITED NICKEL
OVERALL ELECTRODEPOSITED REFLOW TIN
 - GOLD PLATED TERMINAL FINISH
OVERALL UNDERPLATE ELECTRODEPOSITED DUCTILE SULFAMATE NICKEL
CONTACT AREA - ELECTRODEPOSITED GOLD
GRIP AREA - ELECTRODEPOSITED 100% TIN MATTE FINISH
 - SILVER PLATED TERMINAL FINISH
OVERALL UNDERPLATE ELECTRODEPOSITED DUCTILE SULFAMATE NICKEL
CONTACT AREA - ELECTRODEPOSITED PURE SILVER (0.5% MAX IMPURITIES) SEMI-BRIGHT FINISH
- SILVER ANTI-TARNISH : EVABRITE
GRIP AREA - ELECTRODEPOSITED 100% TIN MATTE FINISH
 - MEETS CRIMP PERFORMANCE SPECIFICATION SAE/USCAR-21 (8/2001)
 - MEETS PERFORMANCE STANDARD FOR AUTOMOTIVE ELECTRICAL CONNECTOR SYSTEMS SAE/USCAR-2 REV 3 (APRIL 2001)
 - MEETS FIELD CORRELATED LIFE TEST SAE/USCAR-20 (11/2001)
 - MEETS WIRING COMPONENT DESIGN GUIDELINES SAE/USCAR-12 REV 2 (12/2001)
 - MEETS ELECTRICAL CONNECTION SYSTEM DESIGN SPECIFICATION (SDS) REV 11 (5/2002)
 - REFERENCE PK-31300-516 FOR REEL DIRECTION
 - REFERENCE AS-33000-001 FOR CRIMP INFORMATION

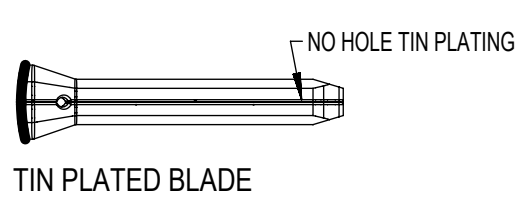
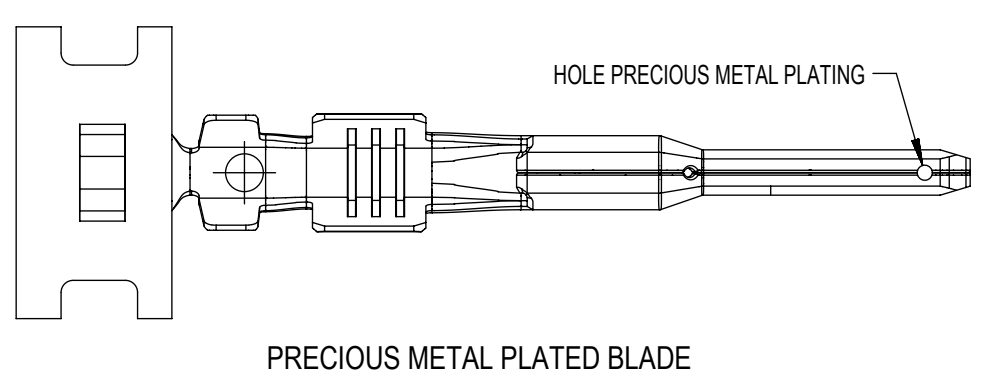

SYMBOLS										THIS DRAWING CONTAINS INFORMATION THAT IS PROPRIETARY TO MOLEX ELECTRONIC TECHNOLOGIES, LLC AND SHOULD NOT BE USED WITHOUT WRITTEN PERMISSION																			
DIMENSION UNITS					SCALE					CURRENT REV DESC:																			
mm					4:1					EC NO: 631014																			
GENERAL TOLERANCES (UNLESS SPECIFIED)										DRWN: NVENKATESHSH 2019/05/11																			
ANGULAR TOL ± 3.0°										CHK'D: ADHIR 2020/03/06																			
4 PLACES ±										APPR: ADHIR 2020/03/06																			
3 PLACES ±										INITIAL REVISION:																			
2 PLACES ± 0.10										DRWN: LPULLIAM 2006/01/31																			
1 PLACE ± 0.3										APPR: bmoser 2006/02/02																			
0 PLACES ±										DRAFT WHERE APPLICABLE MUST REMAIN WITHIN DIMENSIONS																			
THIRD ANGLE PROJECTION					DRAWING					SERIES					MATERIAL NUMBER					CUSTOMER					SHEET NUMBER				
C-SIZE					33000					SEE TABLE					GENERAL MARKET					1 OF 5									

FAMILY	GENDER	SEALING	PLATING	PART NUMBER	PAYOFF DIRECTION	GRIP CODE	WIRE SIZES*	A ±0.30	B ±0.30	C ±0.30	D ±0.30	SPECIAL CHARACTERISTICS
MX150	BLADE	MAT SEAL UNSEALED	Sn	33000-0001	RIGHT (B)	14	14AWG	3.9	3.8	1.7	1.6	HIGH PERFORMANCE Sn
				33000-1001	LEFT (D)		1.50-2.00mm ²					
				33000-0002	RIGHT (B)	18	20/18/16AWG	3.3	3.1	1.3	1.4	
				33000-1002	LEFT (D)		0.75-1.25mm ²					
				33000-0003	RIGHT (B)	22	22AWG	2.5	2.6	0.9	1.0	
				33000-1003	LEFT (D)							
			33000-0004	RIGHT (B)	M3	0.35-0.50mm ²	2.5	2.7	0.9	1.54 ±0.1		
			33000-1004	LEFT (D)								
			Au	33011-1002	RIGHT (B)	14	14AWG	3.9	3.8	1.7	1.6	HIGH PERFORMANCE Au
				33011-0002	LEFT (D)		1.50-2.00mm ²					
				33011-1004	RIGHT (B)	18	20/18/16AWG	3.3	3.1	1.3	1.4	
				33011-0004	LEFT (D)		0.75-1.25mm ²					
				33011-1006	RIGHT (B)	22	22AWG	2.5	2.6	0.9	1.0	
				33011-0006	LEFT (D)							
			33011-1008	RIGHT (B)	M3	0.35-0.50mm ²	2.5	2.7	0.9	1.54 ±0.1		
			33011-0008	LEFT (D)								
			Ag	33011-2003	RIGHT (B)	14	14AWG	3.9	3.8	1.7	1.6	HIGH PERFORMANCE Ag
				33011-3003	LEFT (D)		1.50-2.00mm ²					
				33011-2002	RIGHT (B)	18	20/18/16AWG	3.3	3.1	1.3	1.4	
				33011-3002	LEFT (D)		0.75-1.25mm ²					
				33011-2001	RIGHT (B)	22	22AWG	2.5	2.6	0.9	1.0	
33011-3001	LEFT (D)											
33011-2004	RIGHT (B)	M3	0.35-0.50mm ²	2.5	2.7	0.9	1.54 ±0.1					
33011-3004	LEFT (D)											

* REFERENCE AS-33000-001 FOR SPECIFIC WIRE TYPES

SYMBOLS ▽ = 0 ▽ = 0 ▽ = 0 ▽ = 0 ▽ = 0 ▽ = 0 ▽ = 0 ▽ = 0 ▽ = 0 ▽ = 0	THIS DRAWING CONTAINS INFORMATION THAT IS PROPRIETARY TO MOLEX ELECTRONIC TECHNOLOGIES, LLC AND SHOULD NOT BE USED WITHOUT WRITTEN PERMISSION					
	DIMENSION UNITS	SCALE	CURRENT REV DESC:			
	mm		EC NO: 631014			
	GENERAL TOLERANCES (UNLESS SPECIFIED)		DRWN: NVENKATESHSH	2019/05/11		
	ANGULAR TOL ± 3.0°		CHK'D: ADHIR	2020/03/06		
	4 PLACES ±		APPR: ADHIR	2020/03/06		
	3 PLACES ±		INITIAL REVISION:			
	2 PLACES ± 0.10		DRWN: LPULLIAM	2006/01/31		
	1 PLACE ± 0.3		APPR: bmoser	2006/02/02		
	0 PLACES ±		THIRD ANGLE PROJECTION			
DRAFT WHERE APPLICABLE MUST REMAIN WITHIN DIMENSIONS		DRAWING	SERIES	MATERIAL NUMBER	CUSTOMER	SHEET NUMBER
		C-SIZE	33000	SEE TABLE	GENERAL MARKET	2 OF 5



MX150 1.5MM BLADE TERMINAL

PRODUCT CUSTOMER DRAWING

DOCUMENT NUMBER	DOC TYPE	DOC PART	REVISION
SD-33000-001	PSD	001	D2

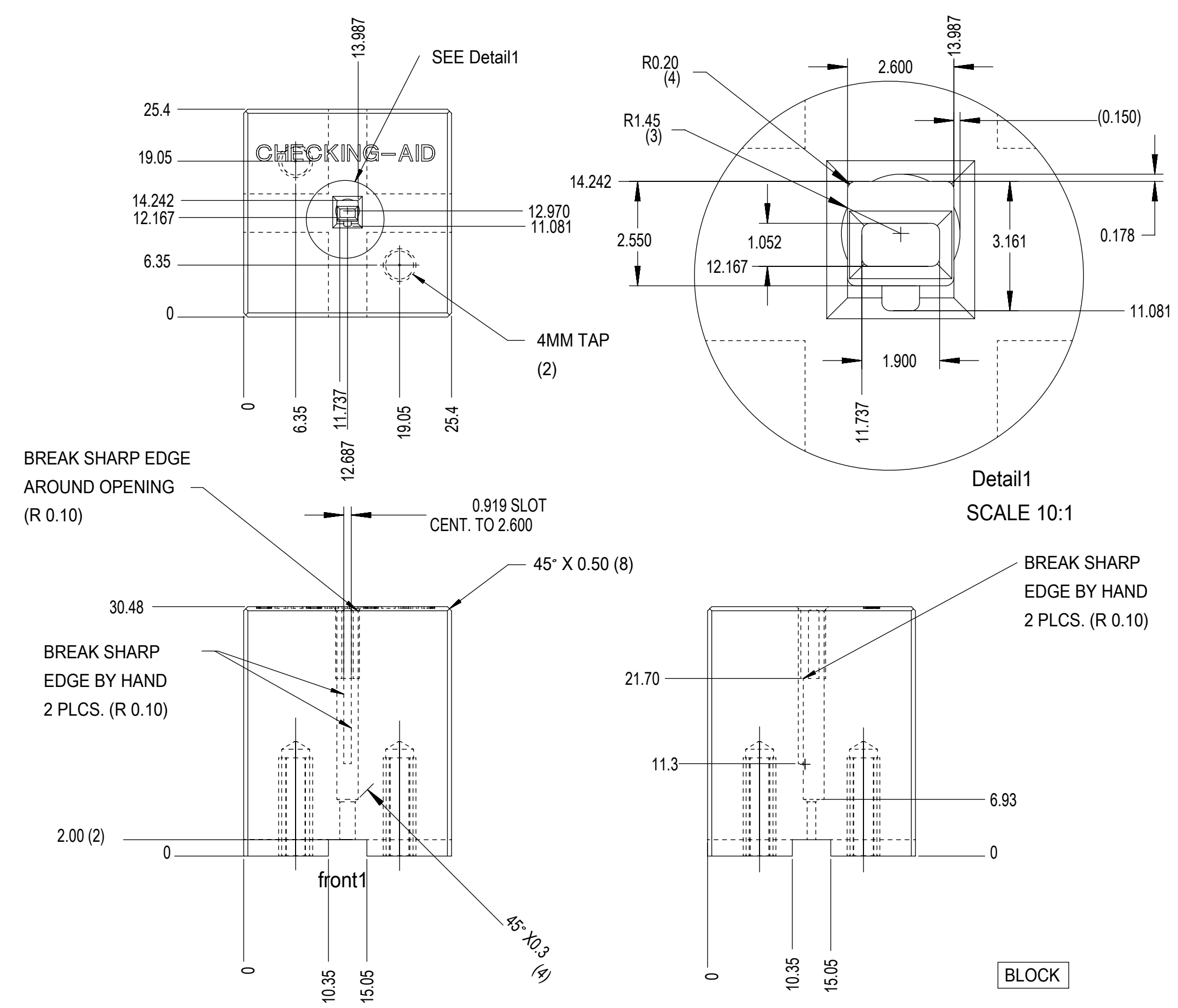

CHECKING-AID
 2 PIECE ASM. A2 TOOL STEEL
 HARDEN & GRIND TO A ROCKWELL
 HARDNESS "C" SCALE OF 56-58

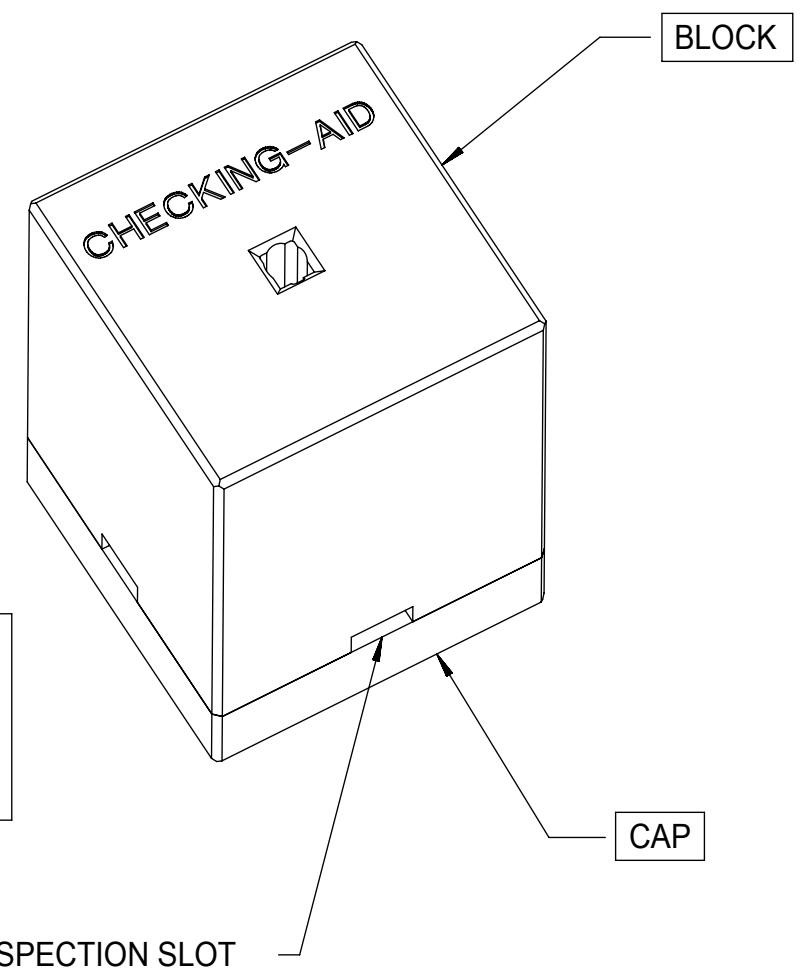

CHECKING AID TOLERANCE
 .XXX = .005
 .XX = .03
 .X = .3

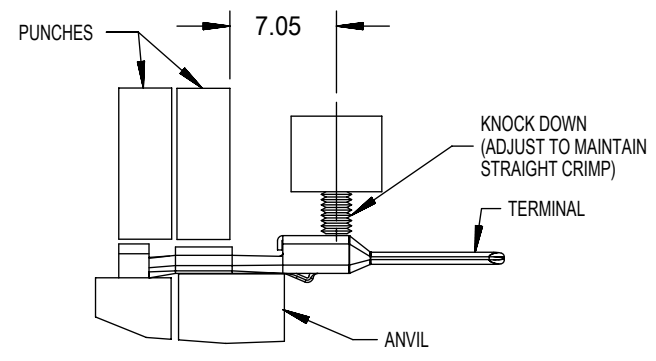

CRIMP TOOLING
 SCALE 2:1

- CRIMP REQUIREMENTS:
1. CRIMP STRAIGHTNESS MUST BE MAINTAINED. USE A KNOCKDOWN TOOL LOCATED AS SHOWN. TERMINAL BOX MUST NOT BE DEFORMED
 2. AFTER CRIMPING, THE TERMINAL AND WIRE MUST FIT FREELY INTO THE CHECKING AID 33000-700. PROPER INSERTION DEPTH IS MET WHEN BLADE TIP STOPS ON CAP. SLOTS PROVIDED TO VISUALLY INSPECT STOPAGE OF PIN TIP.
 3. FOR OTHER MECHANICAL REQUIREMENTS ON CRIMPED TERMINALS, REFER TO SAE/USCAR-21 (5-13-02) SECTIONS 4.2 (VISUAL INSPECTION), 4.3 (CROSS SECTION ANALYSIS) AND 4.4 (CONDUCTOR CRIMP PULLOUT FORCE)

THIS DRAWING CONTAINS INFORMATION THAT IS PROPRIETARY TO MOLEX ELECTRONIC TECHNOLOGIES, LLC AND SHOULD NOT BE USED WITHOUT WRITTEN PERMISSION									
SYMBOLS		DIMENSION UNITS		SCALE		CURRENT REV DESC:			
▽ = 0		mm		2:1		EC NO: 631014			
▽ = 0		GENERAL TOLERANCES (UNLESS SPECIFIED)				DRWN: NVENKATESHSH 2019/05/11			
▽ = 0		ANGULAR TOL ± 3.0°				CHK'D: ADHIR 2020/03/06			
▽ = 0		4 PLACES ±				APPR: ADHIR 2020/03/06			
▽ = 0		3 PLACES ±				INITIAL REVISION:			
▽ = 0		2 PLACES ± 0.10				DRWN: LPULLIAM 2006/01/31			
▽ = 0		1 PLACE ± 0.3				APPR: bmoser 2006/02/02			
▽ = 0		0 PLACES ±				THIRD ANGLE PROJECTION			
▽ = 0		DRAFT WHERE APPLICABLE MUST REMAIN WITHIN DIMENSIONS				DRAWING		SERIES	
▽ = 0		C-SIZE		33000		MATERIAL NUMBER		CUSTOMER	
▽ = 0		SEE TABLE		GENERAL MARKET		DOCUMENT NUMBER		DOC TYPE DOC PART REVISION	
▽ = 0		SD-33000-001		PSD		001		D2	
▽ = 0		SHEET NUMBER		3 OF 5		PRODUCT CUSTOMER DRAWING		MOLEX	
▽ = 0		MX150 1.5MM BLADE TERMINAL							

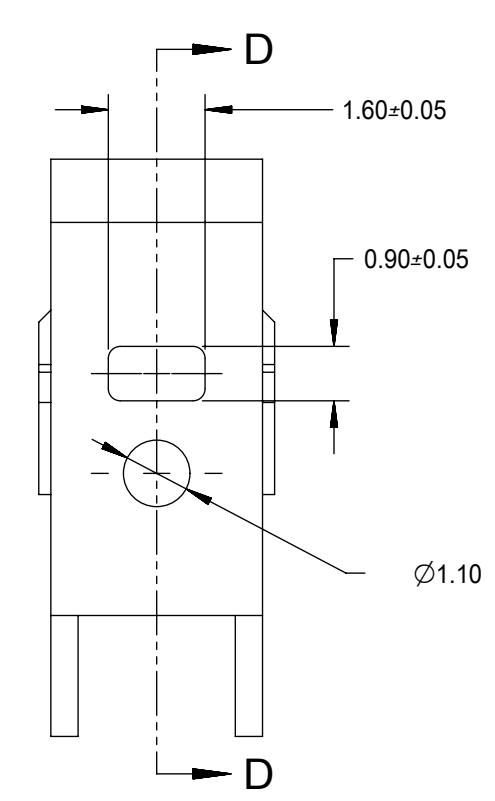
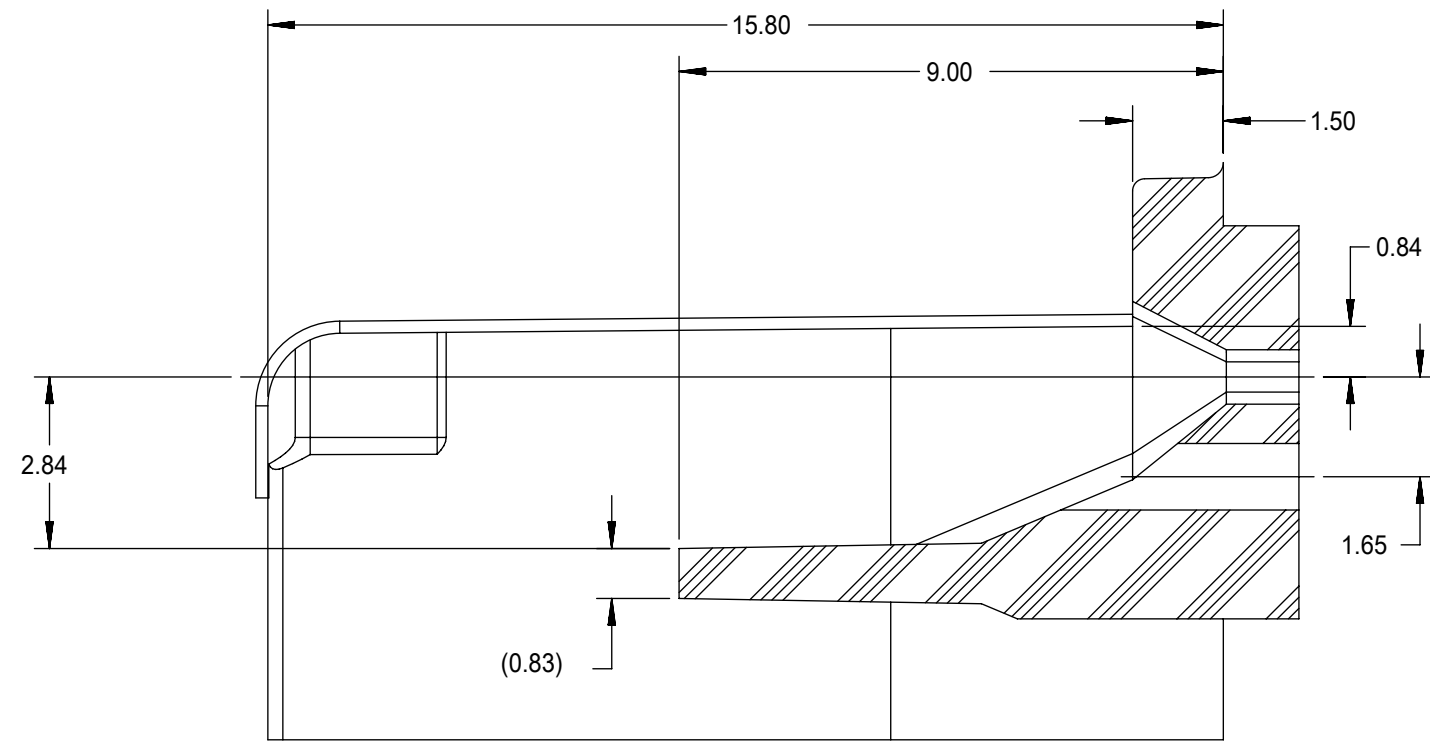
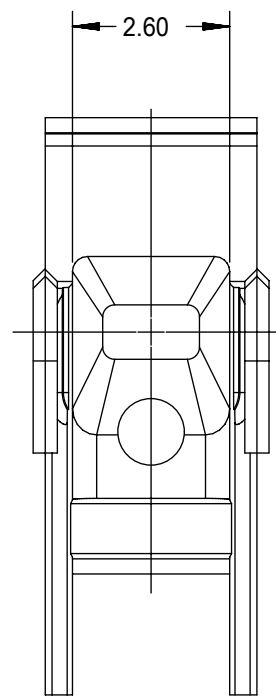

SECTION D-D

TPA/INSERT DETAIL

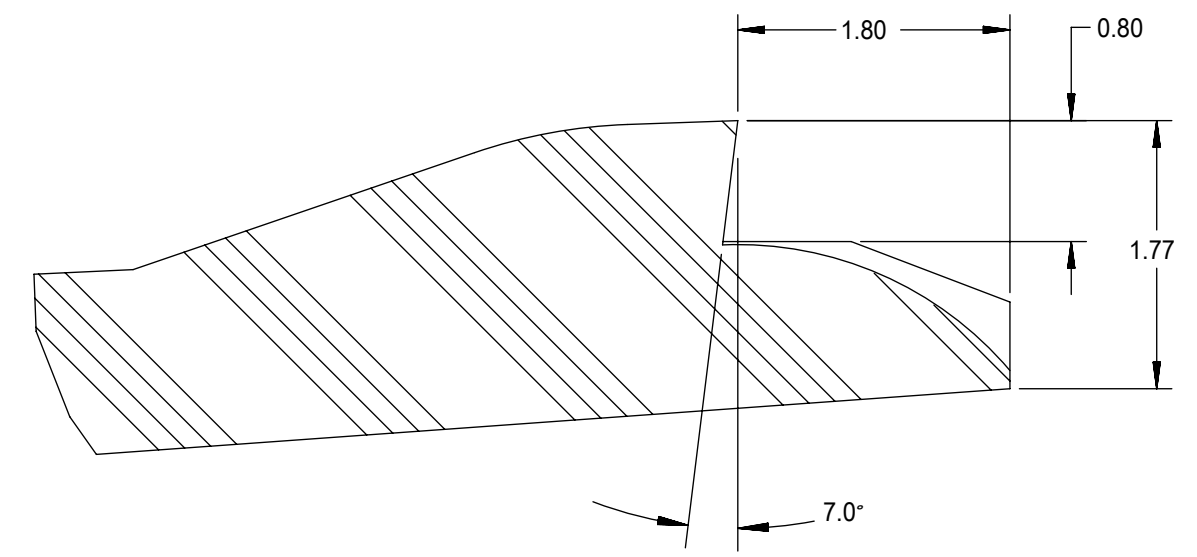
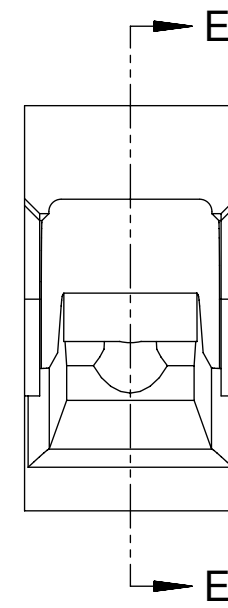
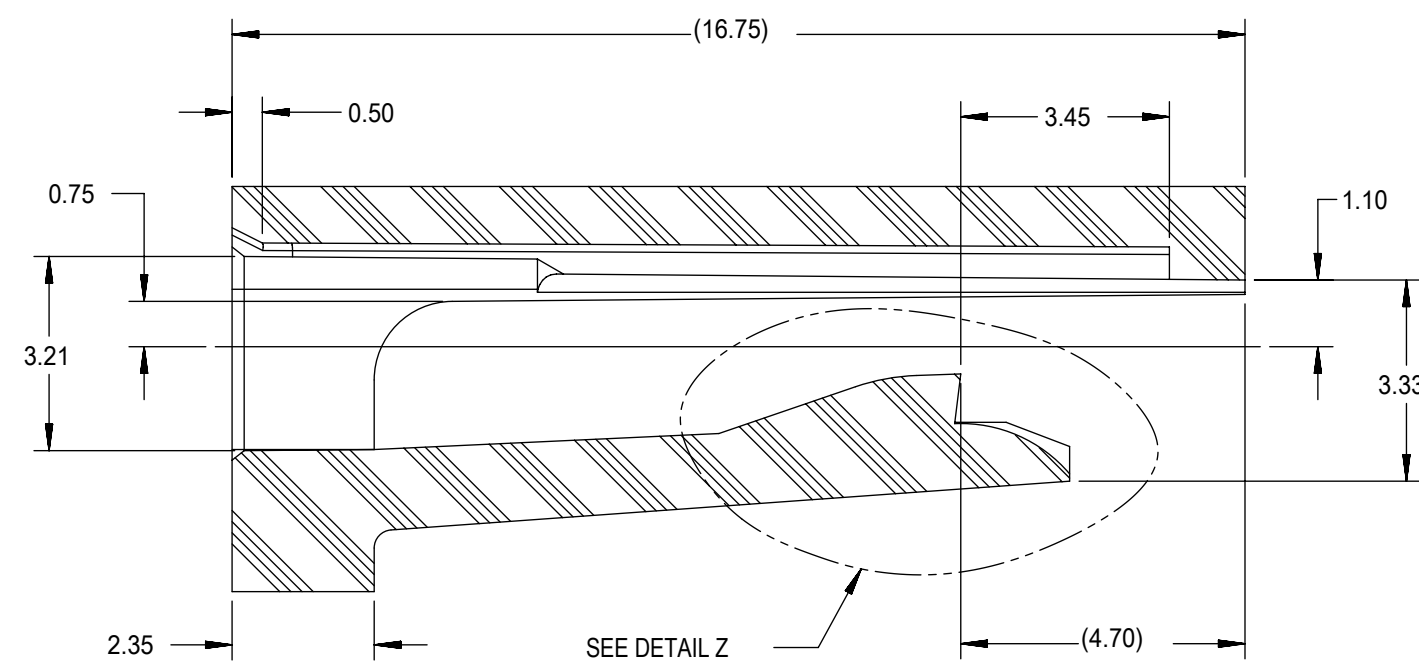
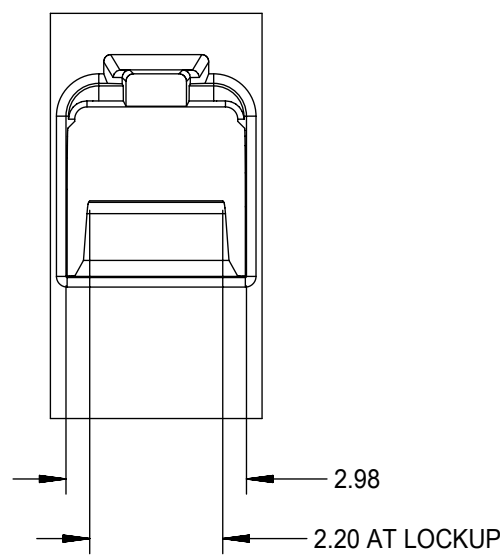

DETAIL Z
SCALE 20:1

SECTION E-E

HOUSING DETAIL

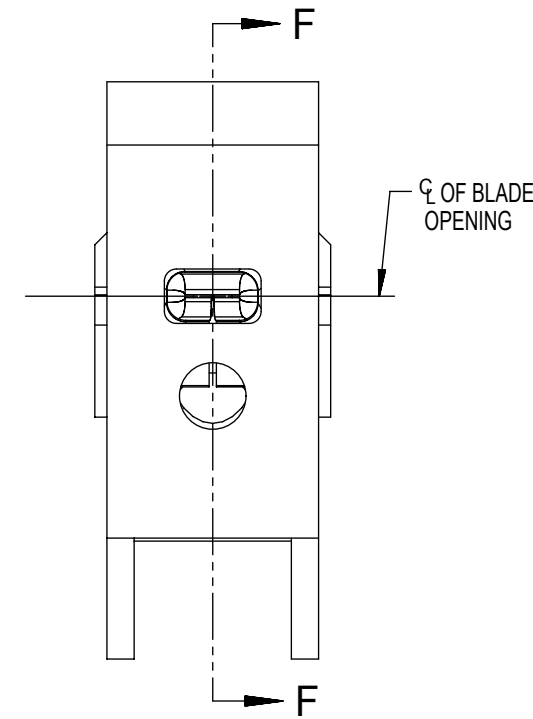
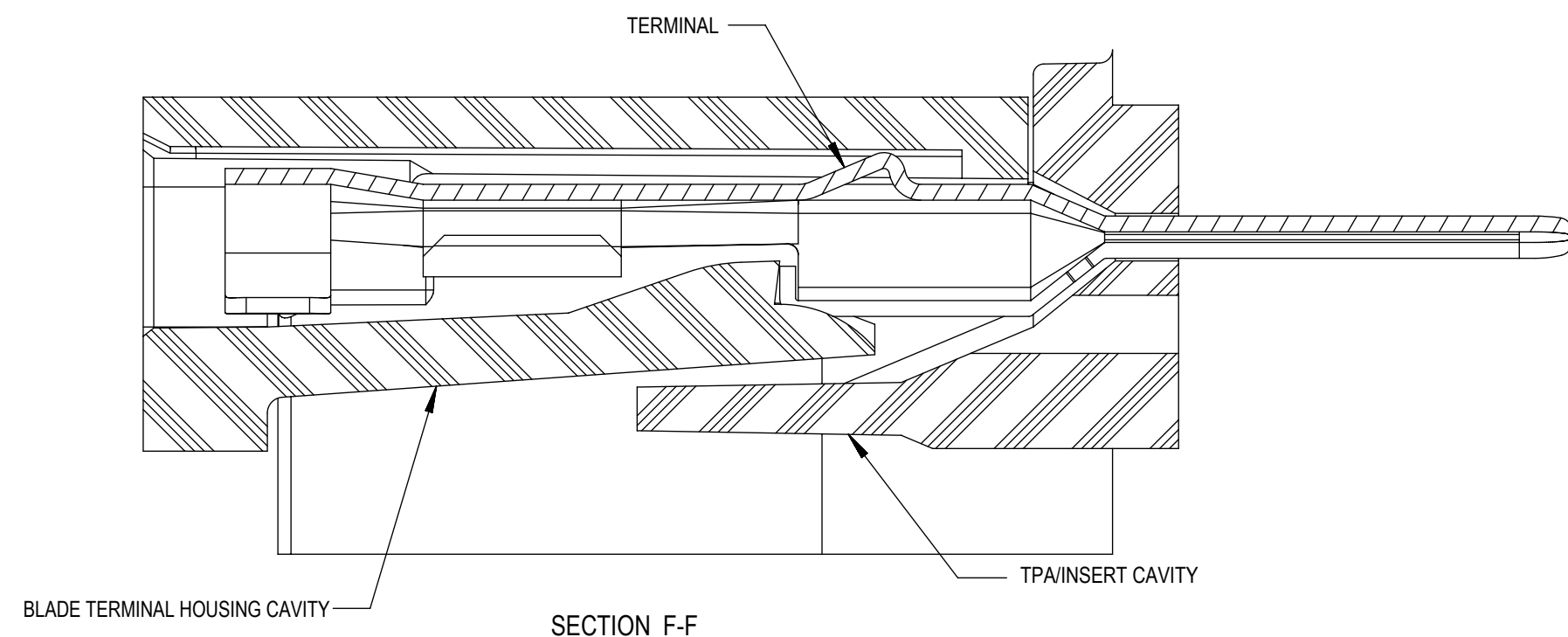
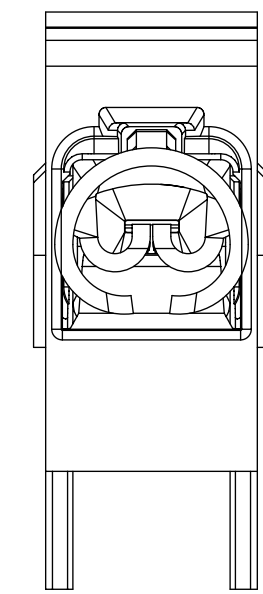

NOTES: (UNLESS OTHERWISE SPECIFIED)

1. TOLERANCES: LINEAR ±0.10
ANGULAR 3°
2. ALL DRAFT WITHIN TOLERANCE
3. MAX RADII ON ALL CORNERS SHOWN SHARP: 0.10
4. MAX FLASH PERMISSIBLE: 0.1
5. EJECTOR PIN MARKS PERMISSIBLE IF FLUSH TO 0.25 BELOW SURFACE
6. MATERIAL: HOUSING/FINGER SPECIFICATION ENGINEERED FOR MATERIAL WITH THE FOLLOWING PROPERTIES:
A. FLEXURAL MODULUS = 4,500 TO 9,400 MPa
PER ASTM TEST D790
B. ELONGATION AT YIELD = 2.3% OR BETTER
PER ASTM TEST D638 TYPE V
7. CAVITY SPEC FOR USE ONLY WITH MOLEX BLADE TERMINAL PART NUMBERS (EXCEPT PIN'S FOR UNSEALED APPLICATIONS) SPECIFIED ELSEWHERE ON THIS DRAWING

BLADE CAVITY ASSEMBLY VIEWS

THIS DRAWING CONTAINS INFORMATION THAT IS PROPRIETARY TO MOLEX ELECTRONIC TECHNOLOGIES, LLC AND SHOULD NOT BE USED WITHOUT WRITTEN PERMISSION									
SYMBOLS DIMENSION UNITS: mm SCALE: 1:1 GENERAL TOLERANCES (UNLESS SPECIFIED): ANGULAR TOL ± 3.0° 4 PLACES ± 3 PLACES ± 2 PLACES ± 0.10 1 PLACE ± 0.3 0 PLACES ± DRAFT WHERE APPLICABLE MUST REMAIN WITHIN DIMENSIONS		CURRENT REV DESC: EC NO: 631014 DRWN: NVENKATESHSH 2019/05/11 CHK'D: ADHIR 2020/03/06 APPR: ADHIR 2020/03/06 INITIAL REVISION: DRWN: LPULLIAM 2006/01/31 APPR: bmoser 2006/02/02			<p>MX150 1.5MM BLADE TERMINAL</p> <p>PRODUCT CUSTOMER DRAWING</p>				
DOCUMENT STATUS: P1 RELEASE DATE: 2020/03/06 02:34:08		THIRD ANGLE PROJECTION DRAWING: C-SIZE SERIES: 33000							

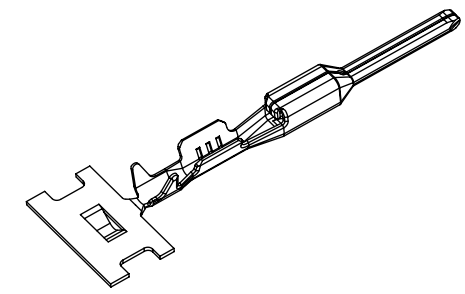

ISO VIEW
SCALE 2:1

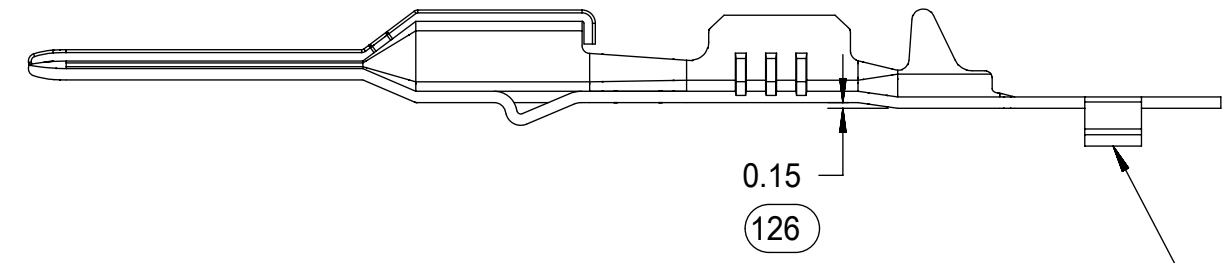
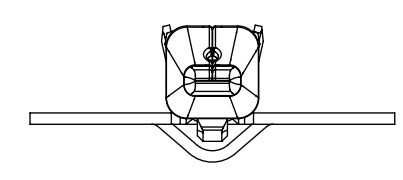
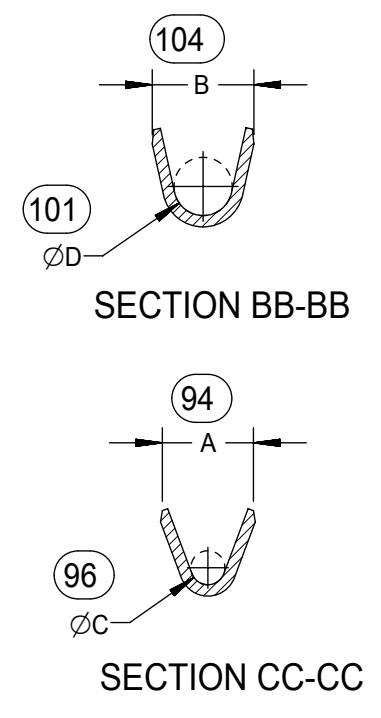
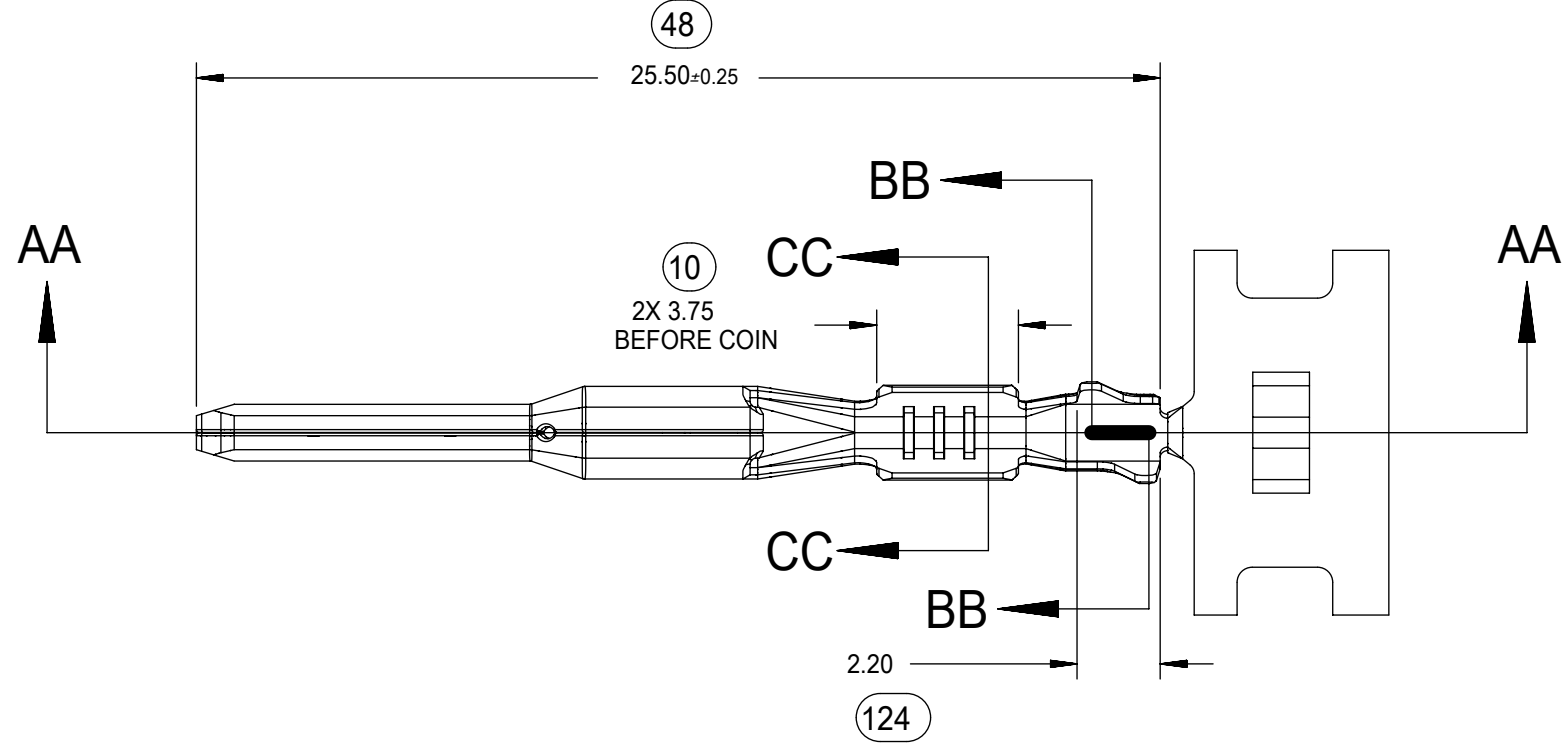

SECTION AA-AA
M3 GRIP CODE TERMINAL
SEE TABLE (SHEET 2) FOR PART NUMBERS

CARRIER BUMP DIRECTION
POINTS DOWN FOR TIN PLATED TERMINALS
POINTS UP FOR PRECIOUS METAL PLATED TERMINALS

THIS DRAWING CONTAINS INFORMATION THAT IS PROPRIETARY TO MOLEX ELECTRONIC TECHNOLOGIES, LLC AND SHOULD NOT BE USED WITHOUT WRITTEN PERMISSION											
SYMBOLS		DIMENSION UNITS		SCALE		CURRENT REV DESC:					
▽ = 0 ▽ = 0 ▽ = 0 ▽ = 0 ▽ = 0 ▽ = 0 ▽ = 0 ▽ = 0 ▽ = 0		mm		5:1		EC NO: 631014 DRWN: NVENKATESHSH 2019/05/11 CHK'D: ADHIR 2020/03/06 APPR: ADHIR 2020/03/06					
▽ = 0 ▽ = 0 ▽ = 0 ▽ = 0 ▽ = 0 ▽ = 0 ▽ = 0 ▽ = 0		GENERAL TOLERANCES (UNLESS SPECIFIED)				INITIAL REVISION: DRWN: LPULLIAM 2006/01/31 APPR: bmoser 2006/02/02				DOCUMENT NUMBER SD-33000-001	
▽ = 0 ▽ = 0 ▽ = 0 ▽ = 0 ▽ = 0 ▽ = 0 ▽ = 0 ▽ = 0		ANGULAR TOL ± 3.0° 4 PLACES ± 3 PLACES ± 2 PLACES ± 0.10 1 PLACE ± 0.3 0 PLACES ±				THIRD ANGLE PROJECTION 				DOC TYPE DOC PART REVISION PSD 001 D2	
▽ = 0 ▽ = 0 ▽ = 0 ▽ = 0 ▽ = 0 ▽ = 0 ▽ = 0 ▽ = 0		DRAFT WHERE APPLICABLE MUST REMAIN WITHIN DIMENSIONS		DRAWING SERIES C-SIZE 33000		MATERIAL NUMBER SEE TABLE		CUSTOMER GENERAL MARKET		SHEET NUMBER 5 OF 5	

X-ON Electronics

Largest Supplier of Electrical and Electronic Components

Click to view similar products for [Automotive Connectors](#) category:

Click to view products by [Molex](#) manufacturer:

Other Similar products are found below :

[003-018-000](#) [60403001](#) [60993906-B](#) [M902-2131](#) [M902-2161](#) [72.330.1035.1](#) [73.353.4028.0](#) [F119300-B](#) [F166900](#) [F258300-B](#) [F358300-B](#)
[F407400](#) [F444110](#) [F487000](#) [F509500B-B](#) [827153-1](#) [8N1515-32-24P](#) [9-1326729-8](#) [925474-1](#) [928905-1](#) [964562-4](#) [968782-1](#) [GT17SA-8DS-](#)
[HU](#) [98891-1012](#) [98947-1016](#) [12004475-L](#) [12010290](#) [12010309-B](#) [12015454](#) [12020219-B](#) [12020308](#) [12041318-B](#) [12052225-L](#) [12052466](#)
[12059125](#) [12064869](#) [12004327-B](#) [12010503-B](#) [12015308](#) [12015384](#) [12015909](#) [1-21030-1](#) [12041254](#) [12041318](#) [12047946-B](#) [12047957](#)
[12047957-L](#) [12059473](#) [12066261](#) [12110546](#)