

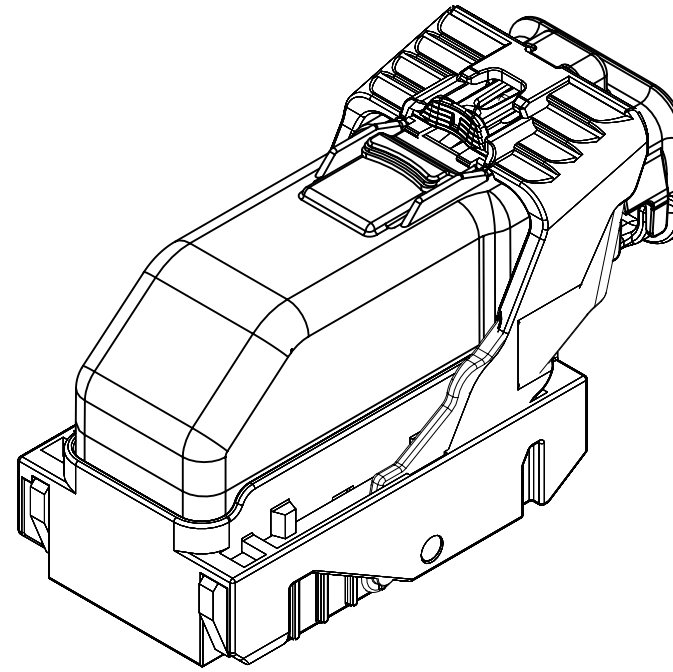

INDEX	
PAGE TITLE	PAGE
TITLE BLOCK	1
REVISION BLOCK	2
PART BLOCK	3
KPC BLOCK	4
COMPONENT TABLE	5
NOTES	6
NOTES	7
WIRE DRESS PACKAGING DIMENSIONS	8
LOCATION AND PACKAGING DIMENSIONS REFERENCING INTERFACE DATUMS B & C	9
LOCATION AND PACKAGING DIMENSIONS REFERENCING INTERFACE DATUM A	10
KEY ID REF - WIRE DRESS OPTION 0	11
KEY ID REF - WIRE DRESS OPTION 9	12
CIRCUIT CONFIGURATIONS	13
CIRCUIT CONFIGURATIONS	14
COMPONENT CONNECTOR INTERFACE	15
COMPONENT CONNECTOR INTERFACE	16
COMPONENT CONNECTOR INTERFACE	17
COMPONENT CONNECTOR INTERFACE	18
COMPONENT CONNECTOR INTERFACE	19
COMPONENT CONNECTOR INTERFACE	20
COMPONENT CONNECTOR INTERFACE	21



ISO VIEW

	<p><b>UNLESS OTHERWISE SPECIFIED:</b> THIS DOCUMENT IS IN ACCORDANCE WITH ASME Y14.5M-1994 AS AMMENDED BY THE GM GLOBAL DIMENSIONING AND TOLERANCING ADDENDUM-1997. ALL GEOMETRIC TOLERANCES AND RELATED DATUMS APPLY RFS. RULE #1 (PERFECT FORM AT MMC) DOES NOT APPLY WHEN A RELATIONSHIP BETWEEN FEATURES IS ESTABLISHED BY ORIENTATION OR LOCATION TOLERANCES. SEPARATE POSITION CALLOUTS MAY BE GAGED SEPARATELY REGARDLESS OF DATUM REFERENCES.</p>			DATE						
	 CHANGE RESTRICTED NO MANUAL CHANGES	REFERENCE 12H (MOLEX AUTOMOTIVE)	DRAFTER J SZYMKOWSKI APVD1 D PFAFFINGER APVD2 B BURT APVD3 APVD4 APVD5	22DE05 22DE05 22DE05    						
DO NOT SCALE	DRAWING NAME HARNESS CONN ASM 66/73/80 CKTS									
METRIC DIMENSIONS SHOWN IN MILLIMETERS UNLESS OTHERWISE SPECIFIED	DRAWING NUMBER 12642695		DWG STATUS <table border="1"> <tr> <td>ST</td> <td>REV</td> <td>PD1</td> </tr> <tr> <td>R</td> <td>002</td> <td></td> </tr> </table>		ST	REV	PD1	R	002	
ST	REV	PD1								
R	002									
			PAGE NUMBER 1 OF 21							

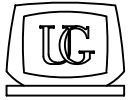
PAGE	DWG STATUS					REVISION HISTORY	AUTH	DR	CK	ENG
	DATE	ST	REV	CHG	PDI					
	19DE11	R	001			RELEASED TO PRODUCTION AT DLS A	CRMRJB	SC	MRO	GF
3	08MY15	R	002	A		REORDERED PART BLOCK AND ADDED MASS CORRECTED P/N TYPO FROM 12562676 TO 12582676				
3, 5		R	002	B		ADDED 12659312, 12659313, 12653574 AND 12653575				
6		R	002	C		REMOVED NOTE 1 . D . 3 . C				
20		R	002	D		DIM 125 WAS 3.25 DIM 131 WAS 5.5	CRMRJD	DFK	MRO	GF

PAGE	DWG STATUS					REVISION HISTORY	AUTH	DR	CK	ENG
	DATE	ST	REV	CHG	PDI					



KEY PRODUCT CHARACTERISTICS  
(IN ACCORDANCE WITH QN 1805 OR ON 1050)



SAFETY/COMPLIANCE

TOTAL ON  
DRAWING

5



FIT/FUNCTION

LAST NO.  
USED

5

NO	TYPE	DESCRIPTION	RATIONALE	PAGE/ZONE
1	F/F	32.68	IMPROVE CONNECTOR SYSTEM MATING	15
2	F/F	29.00	INSURE PROPER RELEASE OF LEVER	15
3	F/F	15.25	INSURE FINAL MATE POSITION	16
5	F/F	POSITIONAL TOLERANCE (2 PLACES)	INSURE CONNECTOR SYSTEM MATEABILITY	19



PAGE TITLE  
KPC BLOCK

DRAWING NUMBER

12642695

DWG STATUS

ST	REV	PD1
----	-----	-----

R	002	
---	-----	--

PAGE NUMBER

4 OF 21

APPLICABLE COMPONENTS										
LINE	MFG.	MFG. P/N	GM P/N	EFFECTIVE DATE	DESCRIPTION	KEY OPTION	WIRE DRESS OPTION	KEY CONFIG.	COLOR	STATUS
-										
1	MOLEX	34565-0003	12582676	02JN03	MX123 DRESS COVER 66/73/80 CKT	N/A	N/A	N/A	BLACK	AVAILABLE
2	MOLEX	34822-0013	12642692	01SP13	MX123 HRNS CONN ASSY 66 CKT	A	0	1458	BLACK	AVAILABLE
3	MOLEX	34822-0033	12659312	01SP13	MX123 HRNS CONN ASSY 66 CKT	C	0	2467	BLUE	AVAILABLE
4	MOLEX	34822-0023	12642693	01SP13	MX123 HRNS CONN ASSY 66 CKT	A	9	1458	BLACK	AVAILABLE
5	MOLEX	34822-0043	12659313	01SP13	MX123 HRNS CONN ASSY 66 CKT	C	9	2467	BLUE	AVAILABLE
6	MOLEX	34566-0103	12582677	11JN04	MX123 HRNS CONN ASSY 73 CKT	A	0	1458	BLACK	AVAILABLE
7	MOLEX	34566-0203	12582678	11JN04	MX123 HRNS CONN ASSY 73 CKT	B	0	1468	ST GRAY	AVAILABLE
8	MOLEX	34566-0303	12615654	09AP08	MX123 HRNS CONN ASSY 73 CKT	C	0	2467	BLUE	AVAILABLE
9	MOLEX	34566-0403	12647268	T.B.D	MX123 HRNS CONN ASSY 73 CKT	D	0	2367	BROWN	NOT ACTIVE
10	MOLEX	34566-0503	AMJ28633	T.B.D	MX123 HRNS CONN ASSY 73 CKT	E	0	2468	GREEN	NOT ACTIVE
11	MOLEX	34566-0603	12653574	05DC14	MX123 HRNS CONN ASSY 73 CKT	F	0	1357	NATURAL	AVAILABLE
12	MOLEX	34566-0703	12588057	09AP08	MX123 HRNS CONN ASSY 80 CKT	G	0	1358	BLUE	AVAILABLE
13	MOLEX	34566-0803	12588058	11JN04	MX123 HRNS CONN ASSY 80 CKT	H	0	2458	ST GRAY	AVAILABLE
14	MOLEX	34566-0903	12615656	T.B.D	MX123 HRNS CONN ASSY 80 CKT	J	0	2457	BLACK	NOT ACTIVE
15	MOLEX	34566-1003	AMJ28595	T.B.D	MX123 HRNS CONN ASSY 80 CKT	K	0	2357	BROWN	NOT ACTIVE
16	MOLEX	34566-1103	AMJ29057	T.B.D	MX123 HRNS CONN ASSY 80 CKT	L	0	2368	GREEN	NOT ACTIVE
17	MOLEX	34566-1203	AMJ28669	T.B.D	MX123 HRNS CONN ASSY 80 CKT	M	0	2358	NATURAL	NOT ACTIVE
18	MOLEX	34566-1303	12603596	11JN04	MX123 HRNS CONN ASSY 73 CKT	A	9	1458	BLACK	AVAILABLE
19	MOLEX	34566-1403	12603597	11JN04	MX123 HRNS CONN ASSY 73 CKT	B	9	1468	ST GRAY	AVAILABLE
20	MOLEX	34566-1503	12615655	09AP08	MX123 HRNS CONN ASSY 73 CKT	C	9	2467	BLUE	AVAILABLE
21	MOLEX	34566-1603	12647269	T.B.D	MX123 HRNS CONN ASSY 73 CKT	D	9	2367	BROWN	NOT ACTIVE
22	MOLEX	34566-1703	AMJ28698	T.B.D	MX123 HRNS CONN ASSY 73 CKT	E	9	2468	GREEN	NOT ACTIVE
23	MOLEX	34566-1803	12653575	05DC14	MX123 HRNS CONN ASSY 73 CKT	F	9	1357	NATURAL	AVAILABLE
24	MOLEX	34566-1903	12603598	09AP08	MX123 HRNS CONN ASSY 80 CKT	G	9	1358	BLUE	AVAILABLE
25	MOLEX	34566-2003	12603599	11JN04	MX123 HRNS CONN ASSY 80 CKT	H	9	2458	ST GRAY	AVAILABLE
26	MOLEX	34566-2103	12615657	T.B.D	MX123 HRNS CONN ASSY 80 CKT	J	9	2457	BLACK	NOT ACTIVE
27	MOLEX	34566-2203	AMJ29117	T.B.D	MX123 HRNS CONN ASSY 80 CKT	K	9	2357	BROWN	NOT ACTIVE
28	MOLEX	34566-2303	AMJ29136	T.B.D	MX123 HRNS CONN ASSY 80 CKT	L	9	2368	GREEN	NOT ACTIVE
29	MOLEX	34566-2403	AMJ29214	T.B.D	MX123 HRNS CONN ASSY 80 CKT	M	9	2358	NATURAL	NOT ACTIVE
30	MOLEX	34736-2002	12642697	01AU10	MX64 RCPT TERM Ag 18/20 GAGE B (RIGHT PAYOFF)	N/A	N/A	N/A	N/A	AVAILABLE
31	MOLEX	34736-2001	12642696	01AU10	MX64 RCPT TERM Ag 22 GAGE B (RIGHT PAYOFF)	N/A	N/A	N/A	N/A	AVAILABLE
32	MOLEX	34586-0001	T.B.D.	11JN04	MX123 0.64MM GROMMET PLUG	N/A	N/A	N/A	NATURAL	AVAILABLE
33	YAZAKI	7116-4150-02	12588066	02JN03	2.8mm YESC SEALED FEMALE TERMINAL TIN 20/22 GAGE (CABLE RANGE 0.30mm-0.60mm)	N/A	N/A	N/A	N/A	NOT ACTIVE
34	YAZAKI	7116-4151-02	12588067	02JN03	2.8mm YESC SEALED FEMALE TERMINAL TIN 16/18 GAGE (CABLE RANGE 0.75mm-1.40mm)	N/A	N/A	N/A	N/A	NOT ACTIVE
35	YAZAKI	7116-4152-02	12582685	02JN03	2.8mm YESC SEALED FEMALE TERMINAL TIN 14 GAGE (CABLE RANGE 1.50mm-2.50mm)	N/A	N/A	N/A	N/A	AVAILABLE
36	YAZAKI	7158-3111-60	12588068	02JN03	2.8mm CABLE SEAL (wire O.D. range 1.20mm-1.90mm)	N/A	N/A	N/A	GREEN	NOT ACTIVE
37	YAZAKI	7158-3112-70	12588069	02JN03	2.8mm CABLE SEAL (wire O.D. range 1.80mm-2.30mm)	N/A	N/A	N/A	YELLOW	NOT ACTIVE
38	YAZAKI	7158-3113-40	12582686	02JN03	2.8mm CABLE SEAL (wire O.D. range 2.18mm-3.00mm)	N/A	N/A	N/A	WHITE	AVAILABLE
39	YAZAKI	7158-3114-90	T.B.D	02JN03	2.8mm YESC CAVITY PLUG	N/A	N/A	N/A	BLUE	AVAILABLE
40	MOLEX	63811-4200	XX019825	02JN03	MX64 TERM HAND CRIMP TOOL	N/A	N/A	N/A	N/A	AVAILABLE
41	MOLEX	63813-1400	XX019826	02JN03	MX64 TERM SERVICE TOOL	N/A	N/A	N/A	N/A	AVAILABLE
42	MOLEX	63865-8000	XX019827	02JN03	MX64 CRIMP APPLICATOR with TOOL KIT 18/20 GAGE PAYOFF DIRECTION D (left payoff) (contact Molex for payoff detail)	N/A	N/A	N/A	N/A	AVAILABLE
43	MOLEX	63865-8070	XX019828	02JN03	MX64 APPLICATOR TOOL KIT 18/20 GAGE	N/A	N/A	N/A	N/A	AVAILABLE
44	MOLEX	63865-8100	XX019829	02JN03	MX64 CRIMP APPLICATOR with TOOL KIT 22 GAGE PAYOFF DIRECTION D (left payoff) (contact Molex for payoff detail)	N/A	N/A	N/A	N/A	AVAILABLE
45	MOLEX	63865-8170	XX019830	02JN03	MX64 APPLICATOR TOOL KIT 22 GAGE	N/A	N/A	N/A	N/A	AVAILABLE
46	SPX	J35616-64	T.B.D.	02JN03	0.64mm PROBE TOOL (for rcpt)	N/A	N/A	N/A	N/A	AVAILABLE
47	SPX	J35616-64A	T.B.D.	02JN03	0.64mm PROBE TOOL WITH EXT (for rcpt)	N/A	N/A	N/A	N/A	AVAILABLE
48	SPX	J35616-65	T.B.D.	02JN03	0.64mm PROBE TOOL WITH EXT (for pin)	N/A	N/A	N/A	N/A	AVAILABLE
49	SPX	J35616-4A	T.B.D.	02JN03	2.8mm PROBE TOOL (for rcpt)	N/A	N/A	N/A	N/A	AVAILABLE
50	YAZAKI	X39899-J374	12094430	02JN03	2.8mm TERM SERVICE TOOL	N/A	N/A	N/A	N/A	AVAILABLE

002B

\* - MX123 DRESS COVER 73/80/66 CKT MATES TO ANY MX123 HARN CONN ASSY SHOWN ON TABLE ABOVE



PAGE TITLE  
COMPONENT TABLE

DRAWING NUMBER  
12642695

DWG STATUS			PAGE NUMBER
ST	REV	PD1	
R	002		5 OF 21

NOTES: UNLESS OTHERWISE SPECIFIED

1. MATERIAL FOR INTERFACE:

- A. RESIN:
  - 1. 30% G.F. PBT; 20% MAX. (BY WEIGHT) REGRIND.
  - 2. MATING CONNECTOR INTERFACE PART COLOR MUST BE SAME AS MATCHING KEYED HARNESS CONNECTOR ASSEMBLY.
  - 3. MUST BE VALIDATED FOR INDIVIDUAL DEVICE APPLICATION REQUIREMENTS.
- B. 0.64MM PINS:
  - 1. BASE MATERIAL: COPPER ALLOY; CONDUCTIVITY >= 28% IACS AT 20°C; TENSILE STRENGTH >= 635 N/mm<sup>2</sup>; SURFACE ROUGHNESS R<sub>a</sub> 6 MAX.
  - 2. PLATING FINISH: SILVER (Ag). PLATING TO BE 1.9-3.3 μm ELECTRODEPOSITED SEMI-BRIGHT SILVER OVER 1.25-2.25 μm DUCTILE SULPHAMATE NICKEL PER NOTE 1(D).
  - 3. ANTI-TARNISH: SYNTHETIC HYDROCARBON CONTACT SURFACE FINISH OR EQUIVALENT APPLIED WITHOUT VOID TO CONTACT AREA (MIN 3.7mm FROM PIN TIP).
- C. 2.8MM BLADE:
  - 1. BASE MATERIAL: COPPER ALLOY; CONDUCTIVITY >= 28% IACS AT 20°C; TENSILE STRENGTH >= 350 N/mm<sup>2</sup>; SURFACE ROUGHNESS R<sub>a</sub> 6 MAX.
  - 2. PLATING FINISH: TIN. PLATING TO BE 2.5-5.0 μm ELECTRODEPOSITED TIN, MATTE FINISH OVER 1.25-2.5 μm DUCTILE SULPHAMATE NICKEL PER NOTE 1(D).
- D. PLATING REQUIREMENTS:
  - 1. SILVER PLATING
    - a. 99.5% PURE SEMI-BRIGHT WITH NO ORGANIC BRIGHTNERS OR CHROMATES.
  - 2. NICKEL PLATING
    - a. ELECTRODEPOSITED DUCTILE SULFAMATE NICKEL WITH A NON-BRIGHTENED FINISH. NO ORGANIC OR BRIGHTENING AGENTS SHALL BE ALLOWED.
    - b. SHALL ONLY BE USED AS AN UNDERLYING PLATING AND MAY NOT BE USED AS AN ELECTRICAL CONTACT SURFACE PLATING.
    - c. SHALL BE NODULE FREE WHEN VIEWED AT 10X MAGNIFICATION IN MEASURED IN CONTACT SURFACE AREA PLUS 0.5MM PERIMETER AROUND THE CONTACT SURFACE AREA.
    - d. ALL PLATINGS SHALL HAVE A 1.0% MAXIMUM BY WEIGHT IMPURITIES. IMPURITIES ARE DEFINED AS ALL ELEMENTS NOT THE PRIMARY PLATING OR HARDENING AGENT IF APPLICABLE, AS DETERMINED BY WET CHEMICAL ANALYSIS OR AUGER METHOD. NO SINGLE IMPURITY SHALL EXCEED 0.1% MAXIMUM BY WEIGHT.
  - 3. TESTING
    - a. THICKNESS TO BE MEASURED IN CONTACT SURFACE AREA PLUS 0.5MM PERIMETER AROUND THE CONTACT SURFACE AREA AS DESIGNATED IN THE DRAWING. THICKNESS SHALL BE DETERMINED BY METHOD OF X-RAY (XRF).
    - b. PLATING ADHESION SHALL BE TESTED BY A BEND TEST FOR ALL METALS. THE TEST SAMPLE SHALL BE BENT 90 DEGREES TO DETERMINE DEPOSIT ADHESION. TESTING SHALL BE COMPLETED IN ACCORDANCE WITH ASTM SPEC B571.

2. DESIGN - GENERAL:

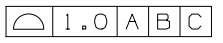
- A. THIS IS A 100% CAD GENERATED PART. THE CAD MATHEMATICAL DATA IS THE MASTER FOR THIS PART. FOR DIMENSIONAL OR ANY INFORMATION NOT SHOWN ON THIS DRAWING, ANALYZE THE CAD MODEL.
- B. TOLERANCES:
  - 1. LINEAR
    - 0.X ± 0.30
    - 0.XX ± 0.10
    - 0.XXX ± 0.10
  - 2. ANGULAR X° ± 3°
  - 3. 
- C. MINIMUM WALL THICKNESS REQUIRED: 1.3mm.
- D. CORNERS SHOWN AS SHARP TO BE R 0.2 MAX.
- E. LETTERING SHALL BE 0.15 MAX RAISED IN 0.20 MAX RECESS PAD. THIS INCLUDES MATERIAL CODE, RECYCLING CODE, CAVITY ID AND DATE CODE.
- F-1. PARTS MUST BE FREE OF DISCOLORATION, SALT RESIDUE AND OTHER IMPERFECTIONS THAT AFFECT FIT OR FUNCTION.
- F-2. SCRATCHES OR DENTS NOT TO EXCEED 0.013mm IN DEPTH.
- G. FOLLOWING PRODUCTION CODES TO BE PERMANENTLY MARKED & HUMAN READABLE TO A LETTER HEIGHT OF 1.5 ± 0.5MM X 0.3 MAX DEEP
  - 1. MATERIAL #: XXXXX-XXXX
  - 2. DATE CODE: JJYY (JULIAN DAY, LAST DIGIT OF YEAR)
  - 3. INSPECTION MACHINE CODE + SERIAL #: X\_XXXXX

3. DESIGN - MANUFACTURING:

- A. DRAFT TO BE WITHIN TOLERANCE.
- B. ALLOWABLE FLASH MAX 0.2 HIGH X MAX 0.13 THICK.
- C. ALLOWABLE PARTING LINE MISMATCH 0.2 MAX.
- D. EJECTOR PINS MARK TO BE FLUSH TO 0.25 MAX DEPRESSED.
- E. ALLOWABLE GATE VESTIGE FLUSH TO 0.25 MAX PROTRUSION.
- F. NO EXTERNAL MOLD RELEASE AGENT ALLOWED DURING MANUFACTURING.
- G. STEEL THAT FORMS THE INDICATED SURFACE MUST BE POLISHED WITH A DIAMOND FINISH (SPI A-2) OVER THE FULL PERIPHERY OF THE TOOL. SURFACE MUST HAVE NO MISMATCH.
- H. ANY PROCESS LUBRICANT REMAINING ON THE TERMINAL MUST NOT VARNISH OR DEGRADE IT'S ELECTRICAL PERFORMANCE UP TO A MAXIMUM CLASS AMBIENT TEMPERATURE PER SAE USCAR-2 FOR 1008 HOURS. PROCESS LUBRICANTS SHOULD BE APPROVED BY THE RESPONSIBLE ENGINEER.
- J. OPTIONAL FEATURES PROVIDED FOR AUTOMATION.
- K. PART MUST BE FREE FROM BURRS AND SHARP EDGES, WHICH MIGHT BE DETRIMENTAL TO SATISFACTORY ASSEMBLY, SAFE HANDLING OR FUNCTION OF PART.
- L. PARTS AS DELIVERED TO ASSEMBLY SHALL BE CLEAN AND FREE OF DEBRIS, RESIDUAL ABRASIVE MATERIAL AND CORROSION PRODUCTS ADVERESLY AFFECTING FUNCTION OR APPEARENCE.
- M. RESTRICTED AND REPORTABLE SUBSTANCES FOR PARTS PER GMW3059.

002C

	PAGE TITLE	DRAWING NUMBER <b>12642695</b>	DWG STATUS			PAGE NUMBER 6 OF 21
	NOTES		ST	REV	PDI	
			R	002		

NOTES: UNLESS OTHERWISE SPECIFIED

4. SYSTEM REQUIREMENTS:

- A. HARNESS CONNECTOR IS COMPATIBLE WITH THE FOLLOWING SAE WIRE SIZE NO'S:
  - 14, MEETING SAE J1128
  - 18, MEETING SAE J1128, MAX O.D. OF 2.06 MM
  - 20, MEETING SAE J1128
  - 22, MEETING SAE J1128, MIN O.D. OF 1.47 MM
- B. CABLE TIE SPECIFICATIONS:
  - 1. CABLE TIE:
    - TENSILE RATING: 220N / (50lbs) MIN
    - TIE LENGTH: 186mm MIN
    - TIE WIDTH: 4.75mm MAX
    - MATERIAL: NYLON
  - 2. INSTALLATION:
    - CABLE TIE TENSION: 190N MIN
  - 3. DRESSED WIRE BUNDLE PACKAGING: SEE FIG. 1
- C. WHEN MATED WITH COMPONENT CONNECTOR INTERFACE AND/OR DRESS COVER, HARNESS CONNECTOR SYSTEM CONFORMS TO THE FOLLOWING:
  - 1. SAE/USCAR-2, REV: 3 APRIL, 2001; CLASS 3
  - 2. FIELD CORRELATED LIFE TEST, SAE/USCAR-20, NOV. 2001
  - 3. GMW #3191 AUGUST 22, 2000 (DRAFT); TEMPERATURE CLASS 3, SEALING CLASS 1, VIBRATION CLASS 2
  - 4. RESTRICTED AND REPORTABLE CHEMICALS PER GMW #3059, REV: D AUGUST 2002
  - 5. TPA USER FORCES (FULLY POPULATED WITH TERMINALS)
    - a. REMOVAL FROM LOCK TO PRE-SET: <=120N
- D. WIRE SPECIFICATIONS:
  - 1. WIRE SURFACE MUST BE FREE OF SCRATCHES, GROOVES OR DENTS WHERE FUNCTIONAL

5. TERMINAL CURRENT RATINGS:

ALL TESTING DONE IN ACCORDANCE WITH USCAR-2 REV5 SECTION 5.3

- A. MX64 RCPT TERM
  - 1. MX64 RCPT TERM Ag 18/20 GAGE CRIMPED TO SAE WIRE SIZE NO.18 AND MATED TO MX123 0.64MM PIN: 11.3 AMPS
  - 2. MX64 RCPT TERM Ag 22 GAGE CRIMPED TO SAE WIRE SIZE NO.22 AND MATED TO MX123 0.64MM PIN:8.5 AMPS

WIRE	CURRENT RATING			
	23°C	85°C	105°C	125°C
18AWG	11.3A	11.3A	9.5A	6.6A
20AWG	10.0A	10.0A	8.3A	5.7A
22AWG	8.6A	8.6A	7.1A	5.0A

- B. 2.8MM RCPT TERM
  - 1. 2.8MM RCPT TERM TIN 14 GAGE CRIMPED TO SAE WIRE SIZE NO.14 AND MATED TO MX123 2.8MM BLADE: 25.6 AMPS

6. CONTACT MOLEX AUTOMOTIVE FOR AVAILABLE CUSTOM PATTERNS OF CAVITIES OPEN FOR CIRCUITS

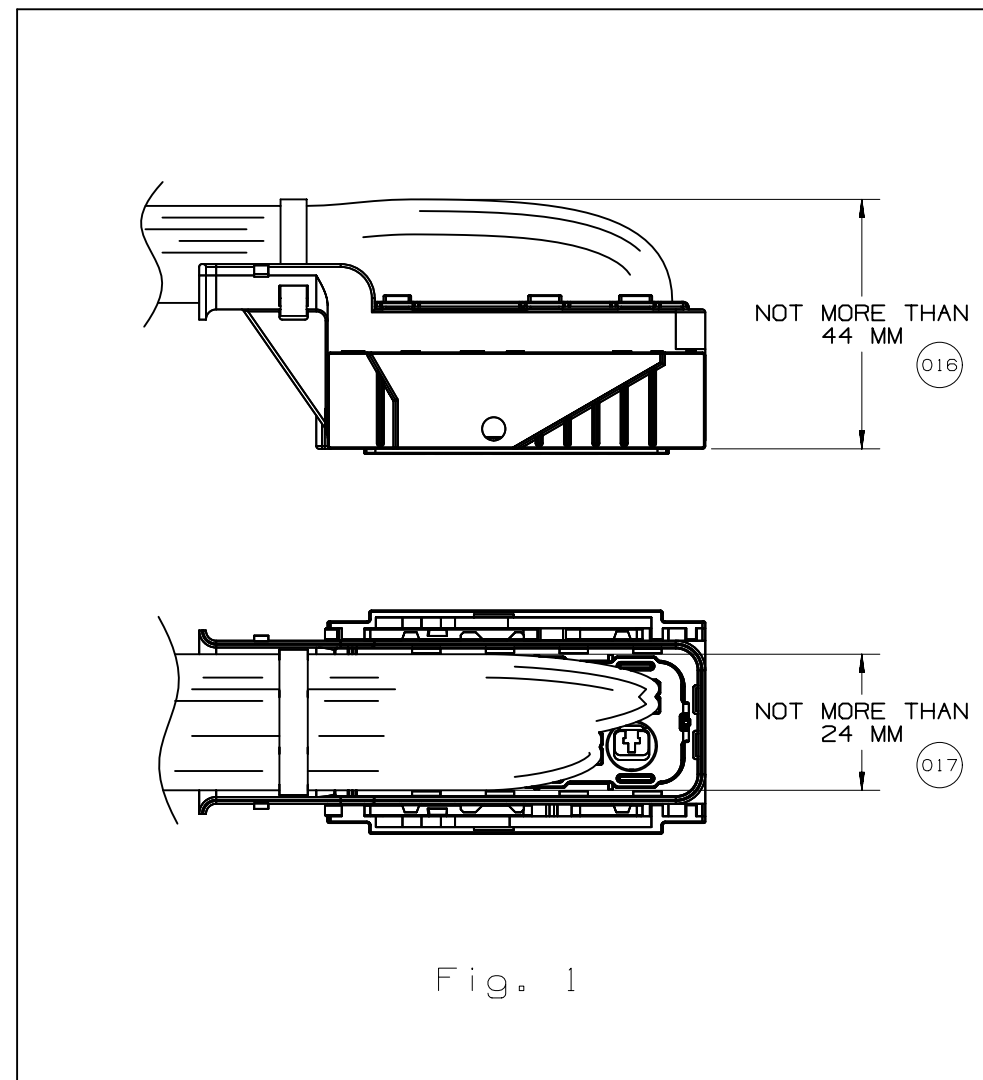
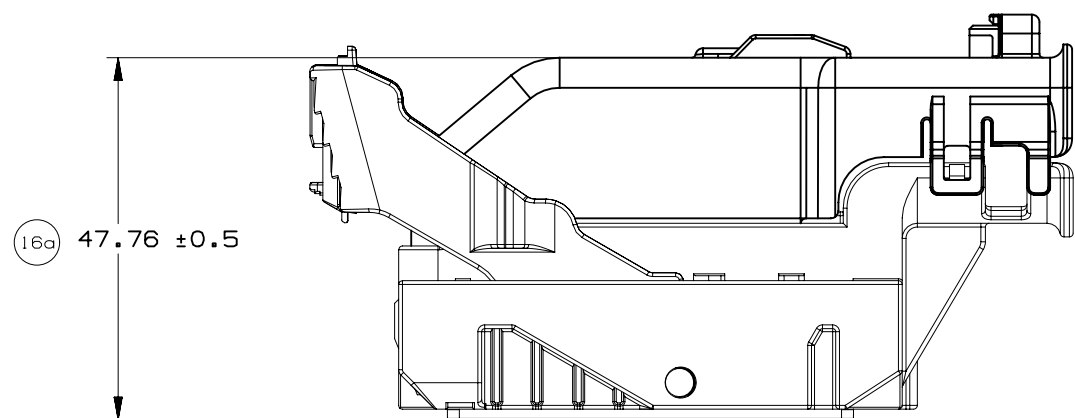



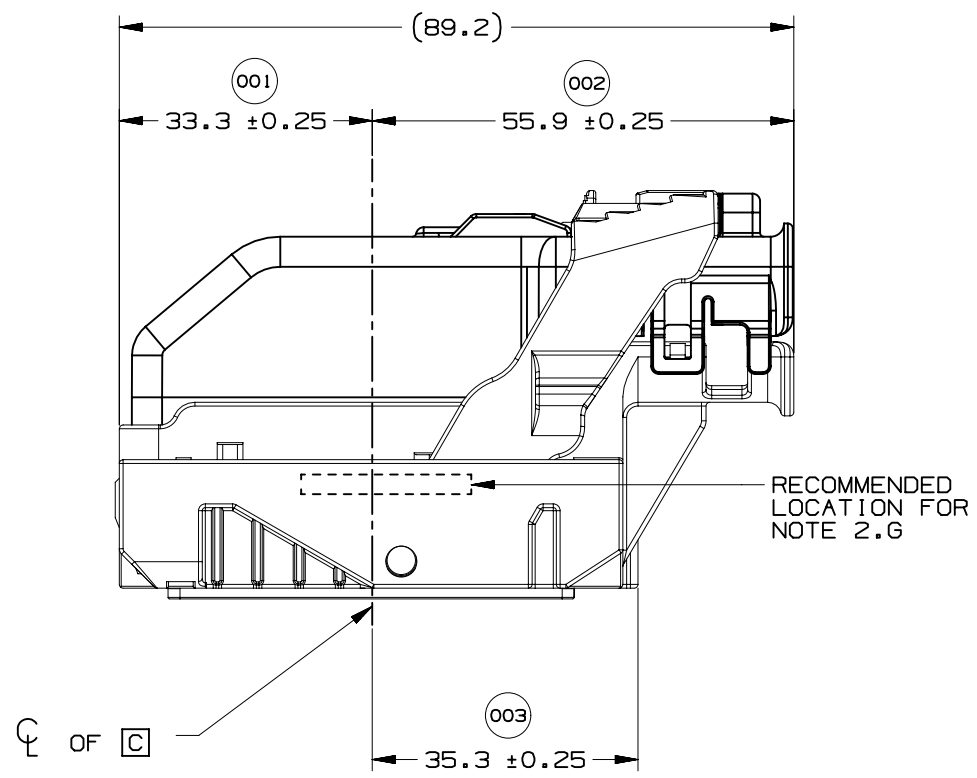

WIRE DRESS OPTION 0 SHOWN

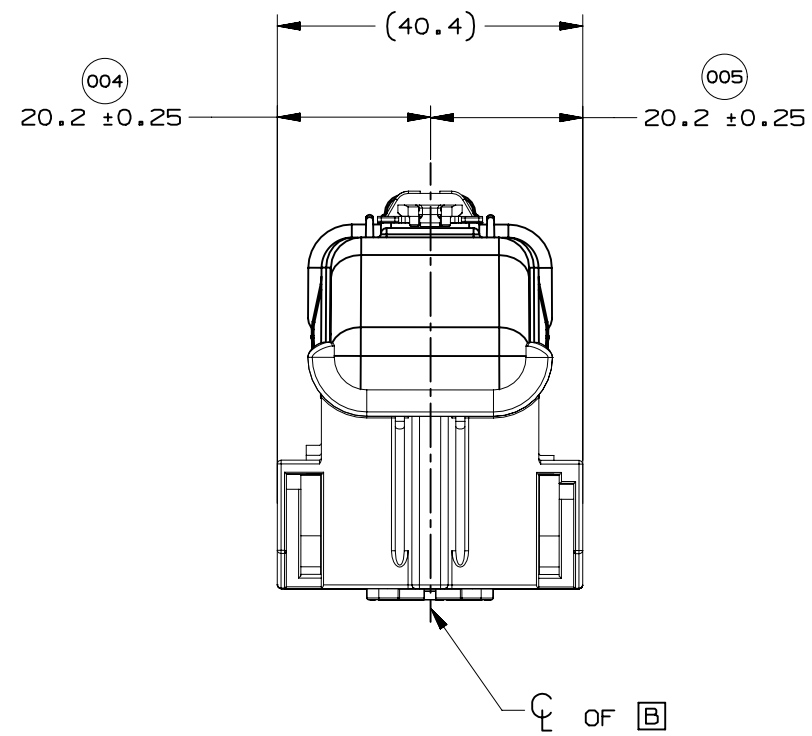

WIRE DRESS OPTION 0 SHOWN

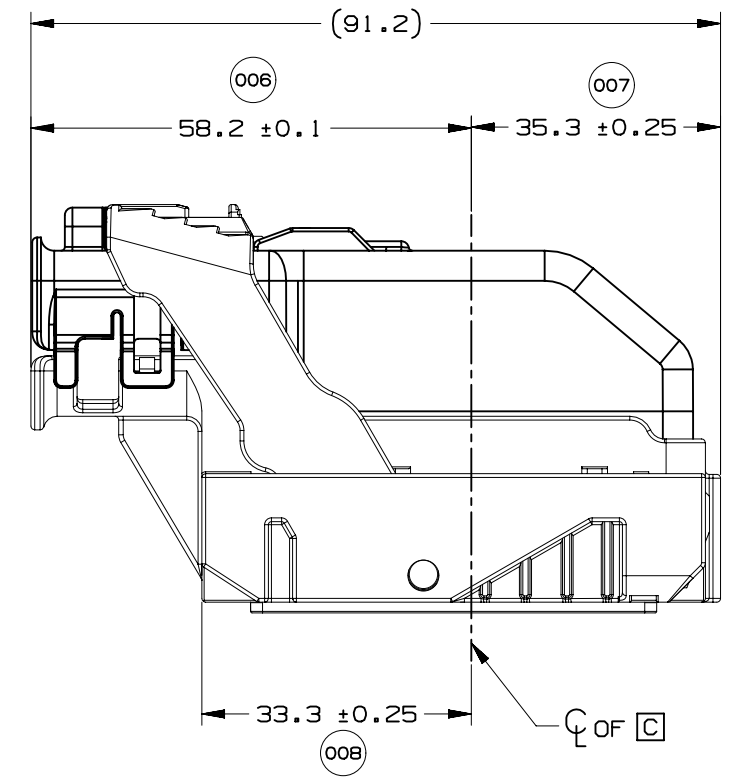

WIRE DRESS OPTION 9 SHOWN



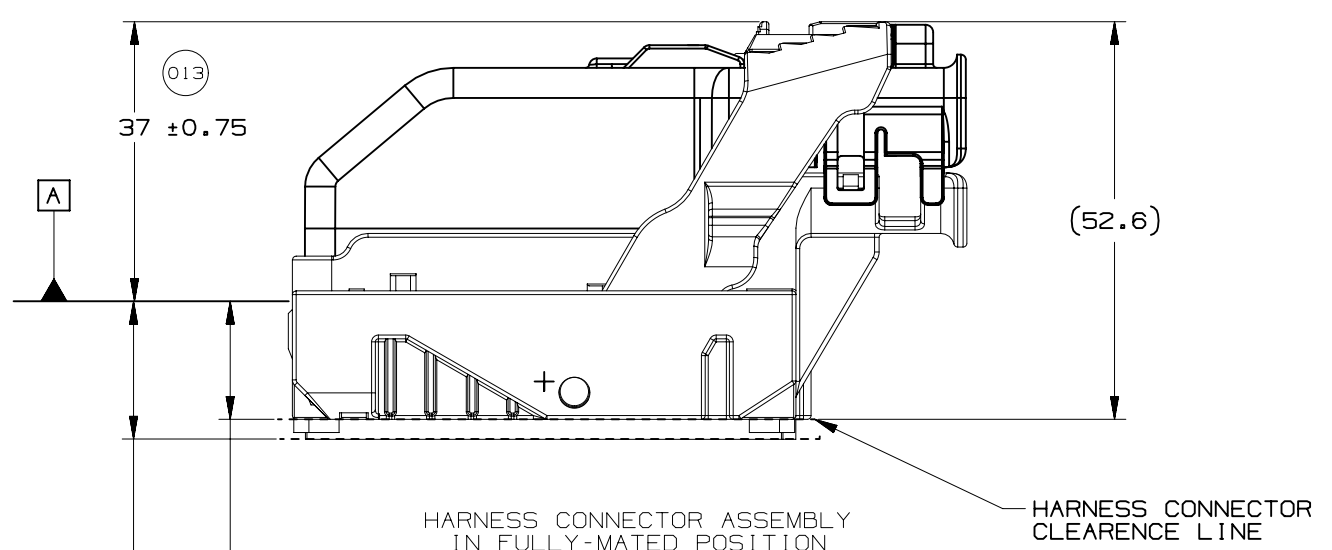
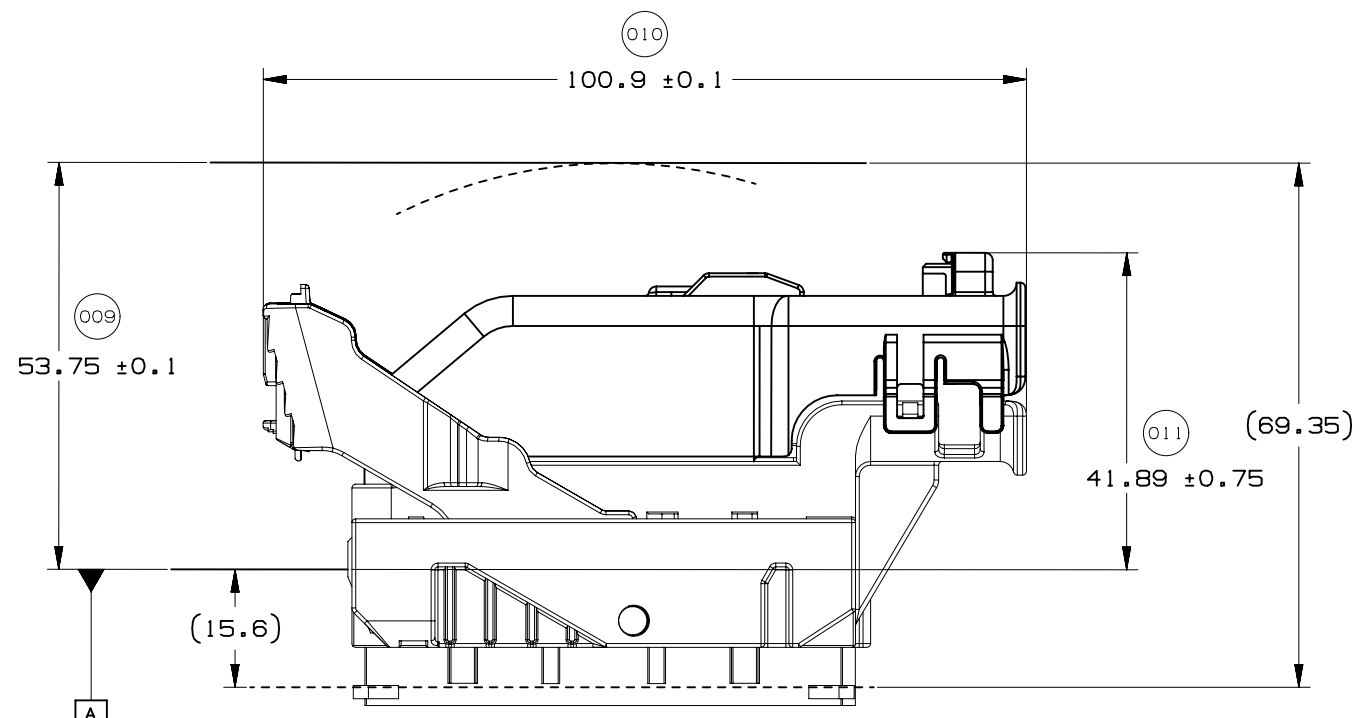
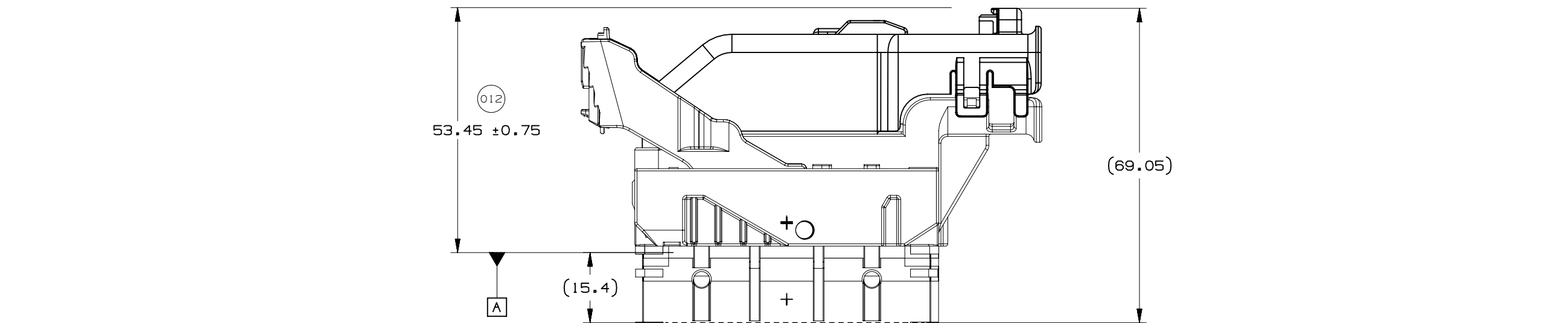

15.6 MIN. ALL AROUND CLEARANCE REQUIRED FOR HARNESS CONNECTOR

014

17.9 MIN. AT PAD LOCATION CLEARANCE REQUIRED FOR HARNESS CONNECTOR CONSTRUCTION BELOW THIS PLANE IS NOT CONTROLLED

015

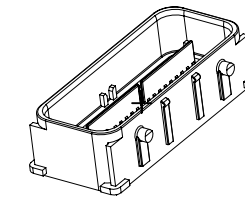
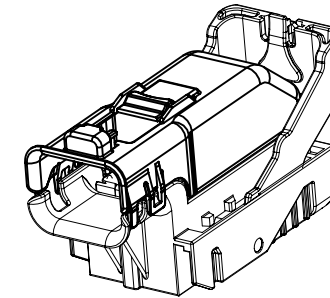
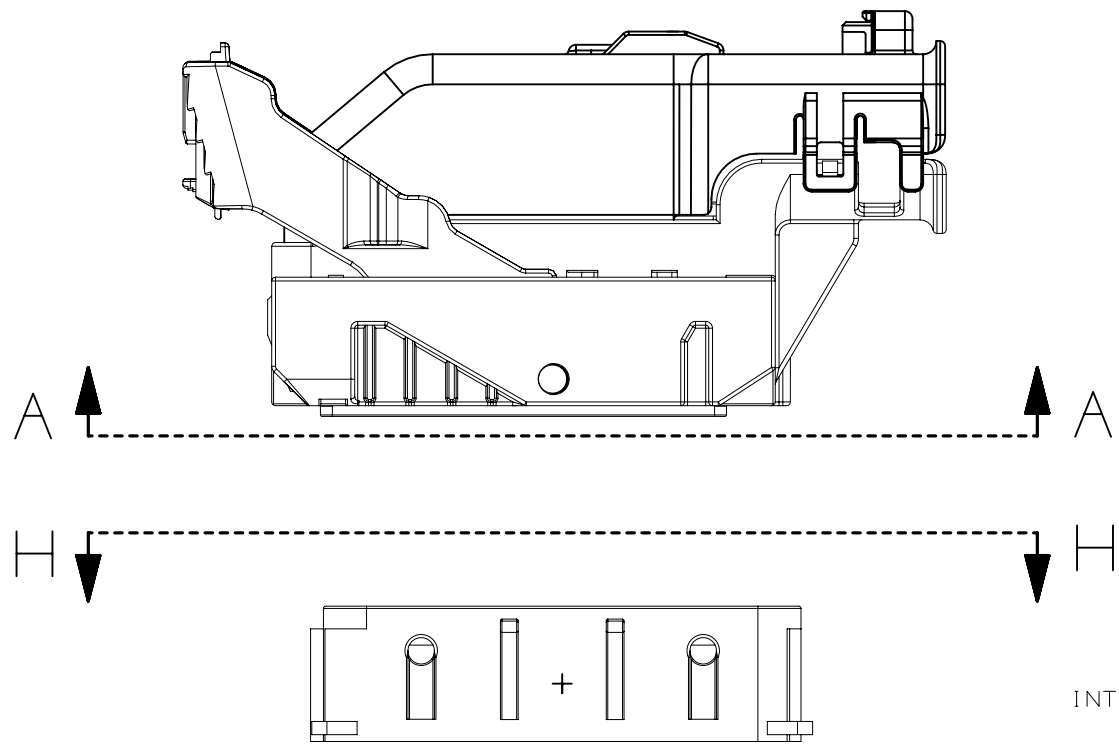

NOTE: REFERENCE THE COMPONENT TABLE FOR KEY OPTIONS AND CONFIGURATIONS

INTERFACE SIDE SHOWN ON ALL SECTION VIEWS

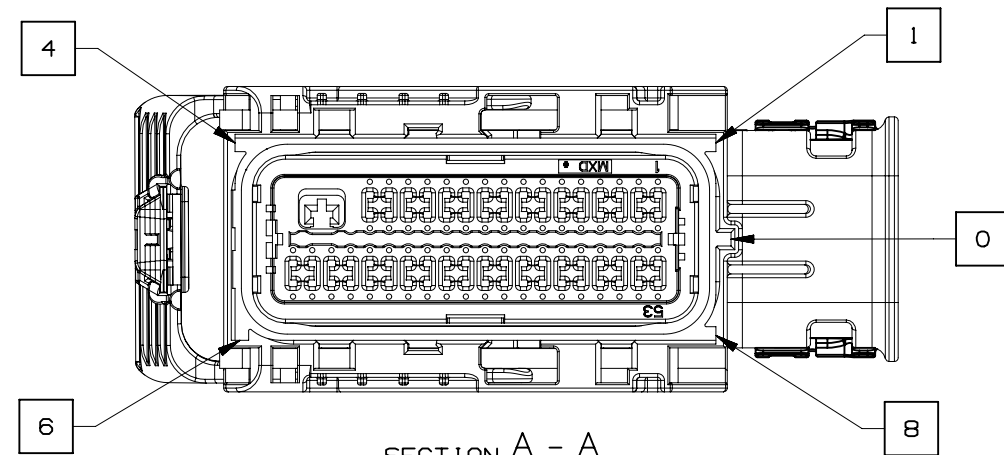

SECTION A - A  
KEY OPTION B SHOWN

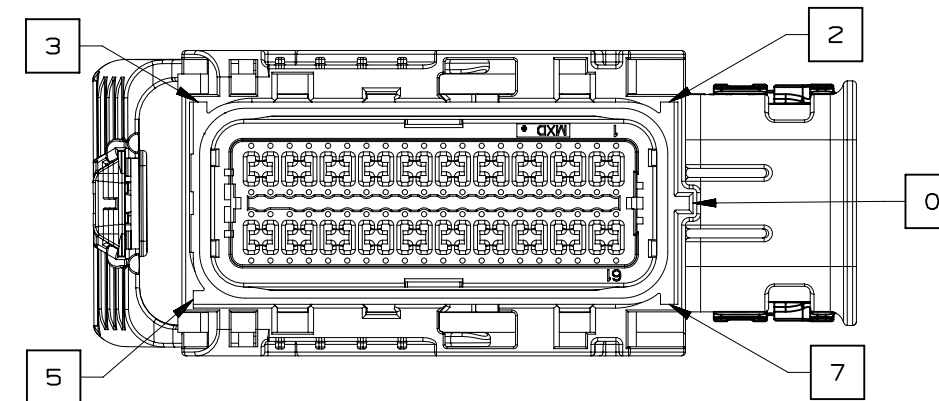

SECTION A - A  
KEY OPTION K SHOWN

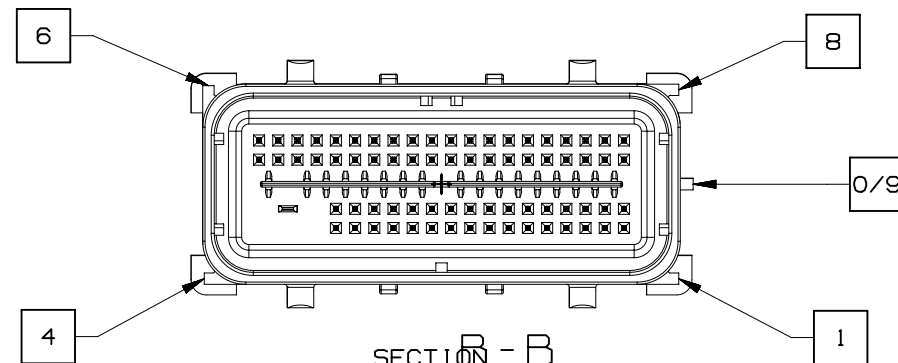

SECTION B - B  
KEY OPTION B SHOWN

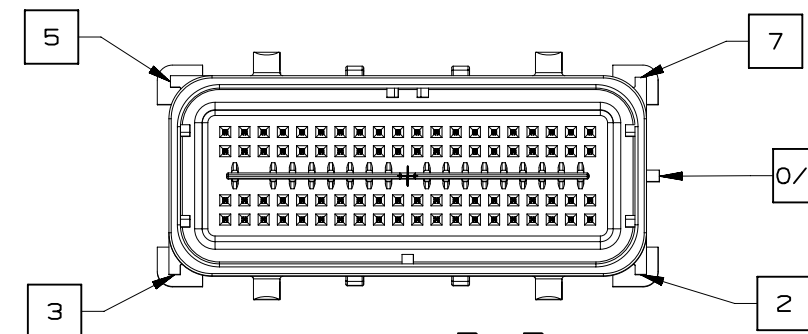

SECTION B - B  
KEY OPTION K SHOWN



PAGE TITLE  
KEY ID REF - WIRE DRESS OPTION 0

DRAWING NUMBER  
12642695

DWG STATUS		
ST	REV	PD1
R	002	

PAGE NUMBER  
11 OF 21

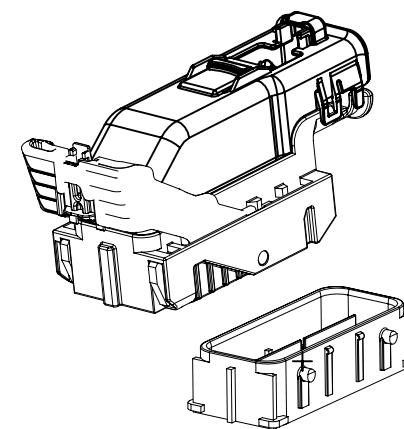
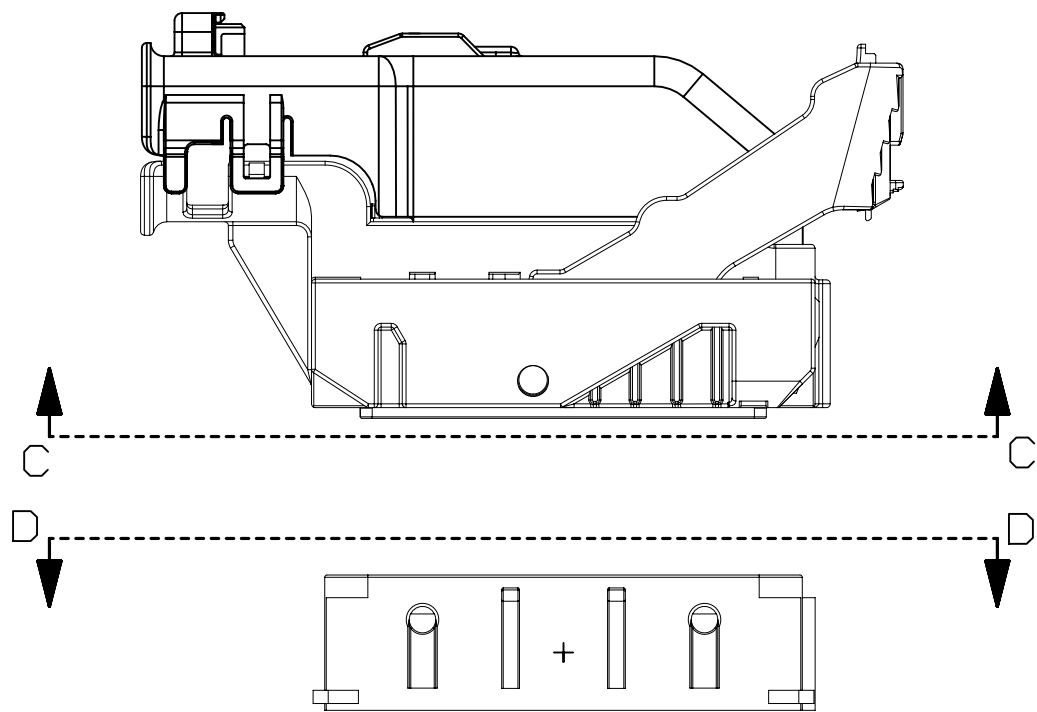

NOTE: REFERENCE THE COMPONENT TABLE FOR KEY OPTIONS AND CONFIGURATIONS

VIEW V

INTERFACE SIDE SHOWN ON ALL SECTION VIEWS

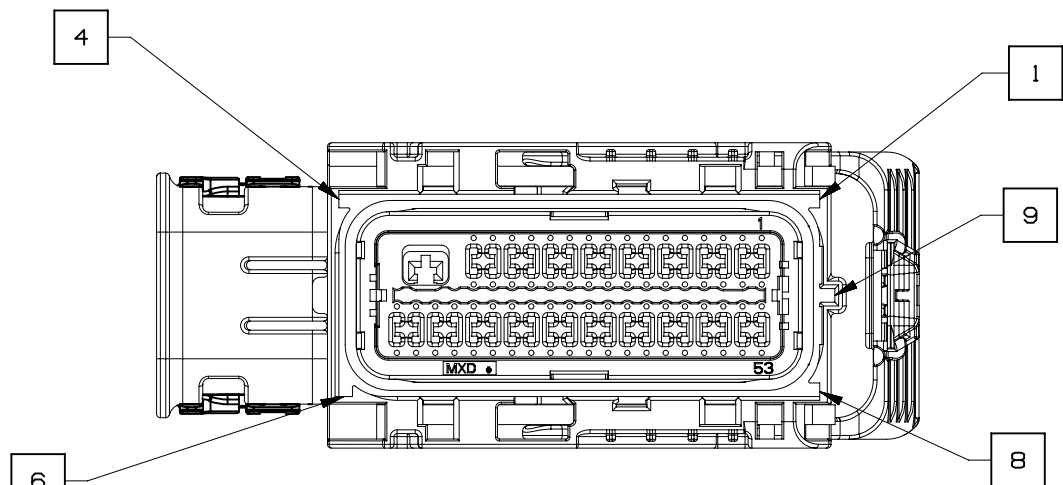

SECTION C-C  
KEY OPTION B SHOWN

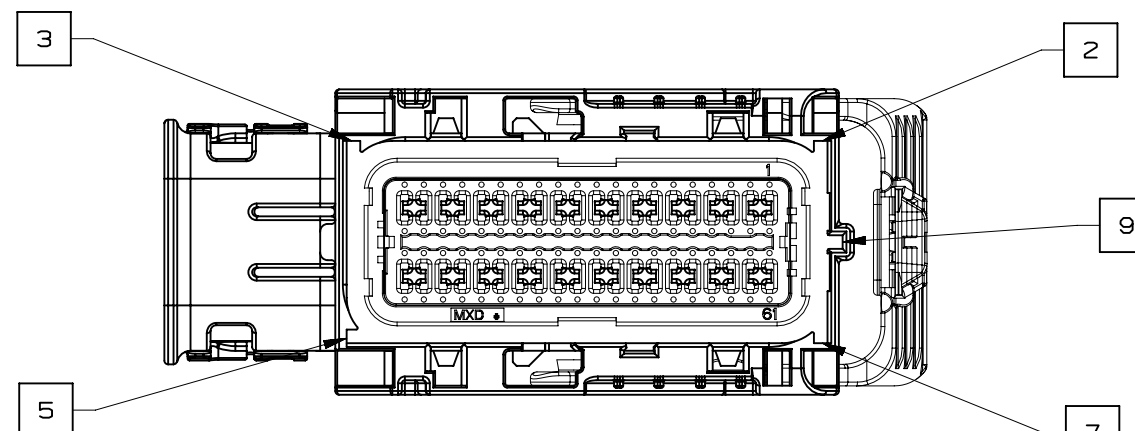

SECTION C-C  
KEY OPTION K SHOWN

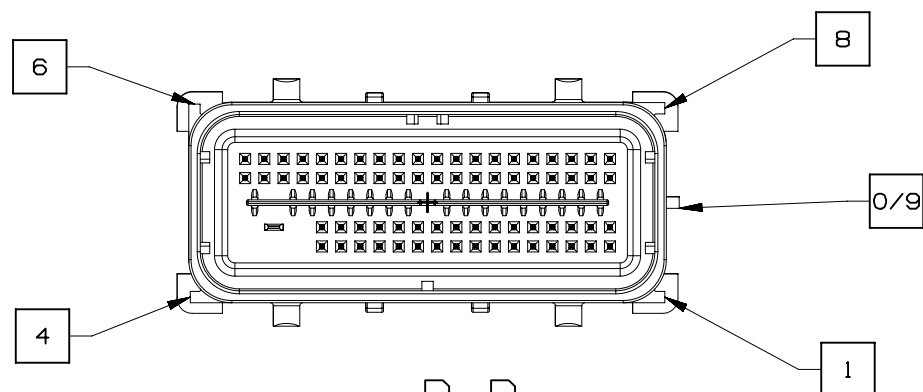

SECTION D-D  
KEY OPTION B SHOWN

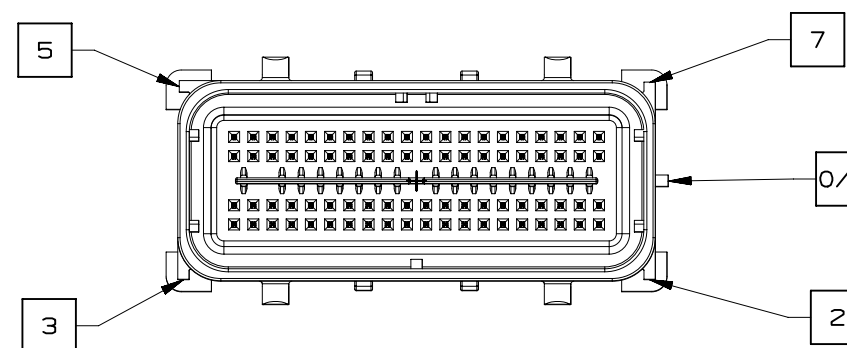

SECTION D-D  
KEY OPTION K SHOWN



PAGE TITLE  
KEY ID REF - WIRE DRESS OPTION 9

DRAWING NUMBER  
12642695

DWG STATUS		
ST	REV	PD1
R	002	

PAGE NUMBER  
12 OF 21

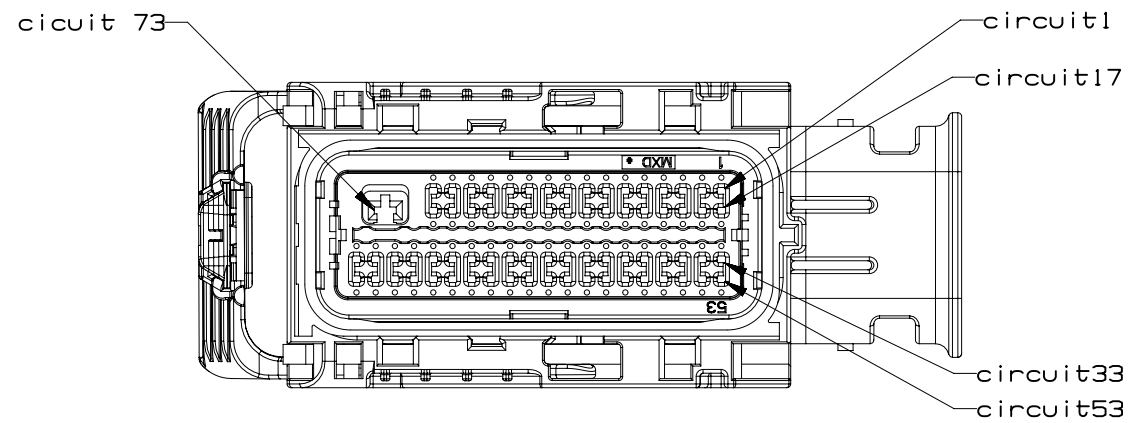

73 CKT HARNESS CONNECTOR ASSEMBLY  
WIRE DRESS OPTION 0

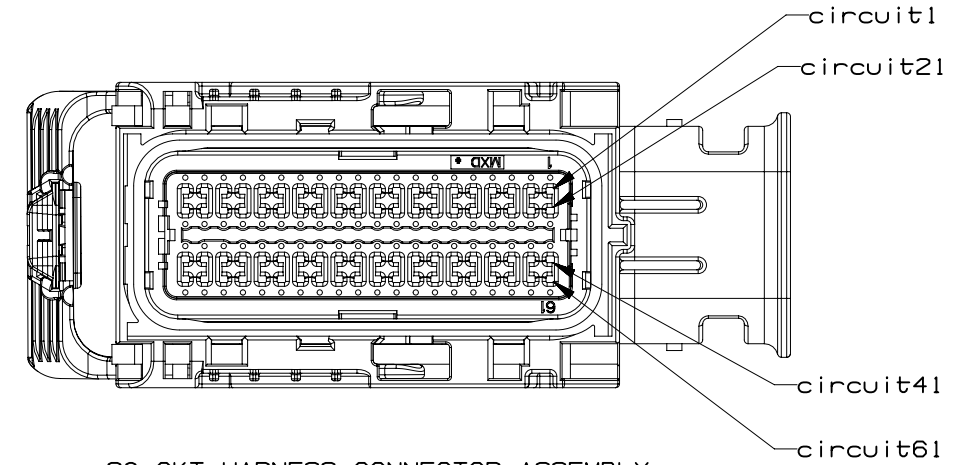

80 CKT HARNESS CONNECTOR ASSEMBLY  
WIRE DRESS OPTION 0

INTERFACE SIDE SHOWN ON ALL VIEWS

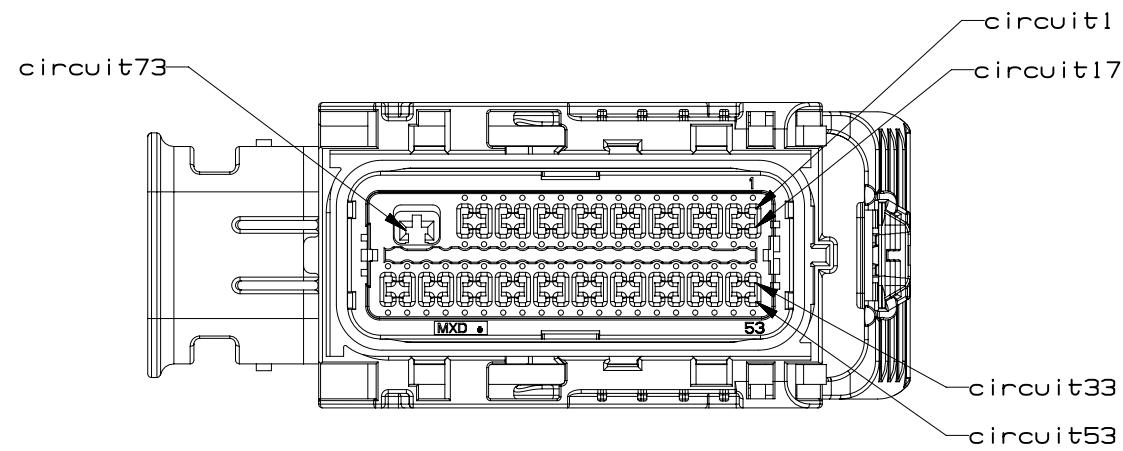

73 CKT HARNESS CONNECTOR ASSEMBLY  
WIRE DRESS OPTION 9

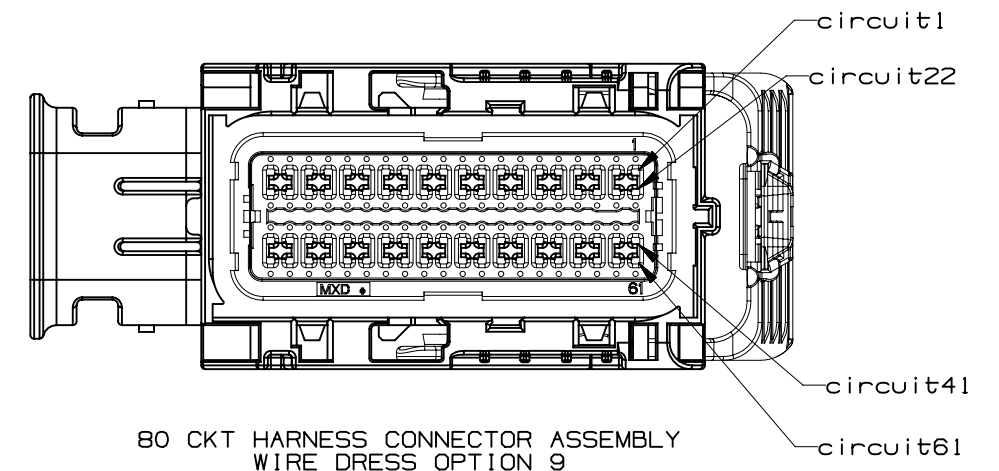

80 CKT HARNESS CONNECTOR ASSEMBLY  
WIRE DRESS OPTION 9

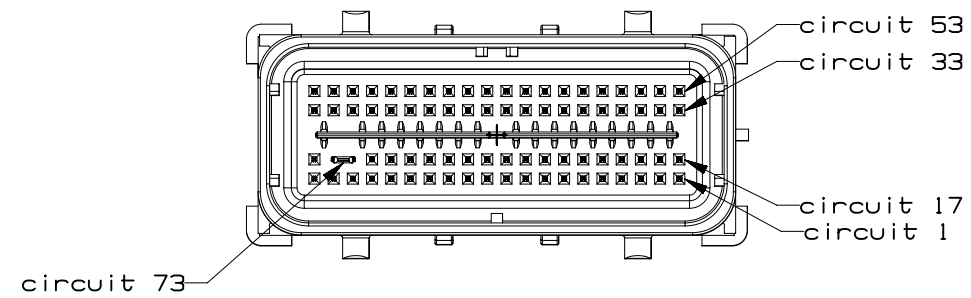

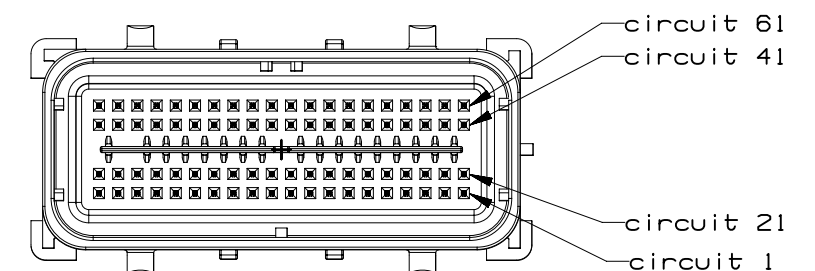

73 CKT COMPONENT CONNECTOR INTERFACE



80 CKT COMPONENT CONNECTOR INTERFACE

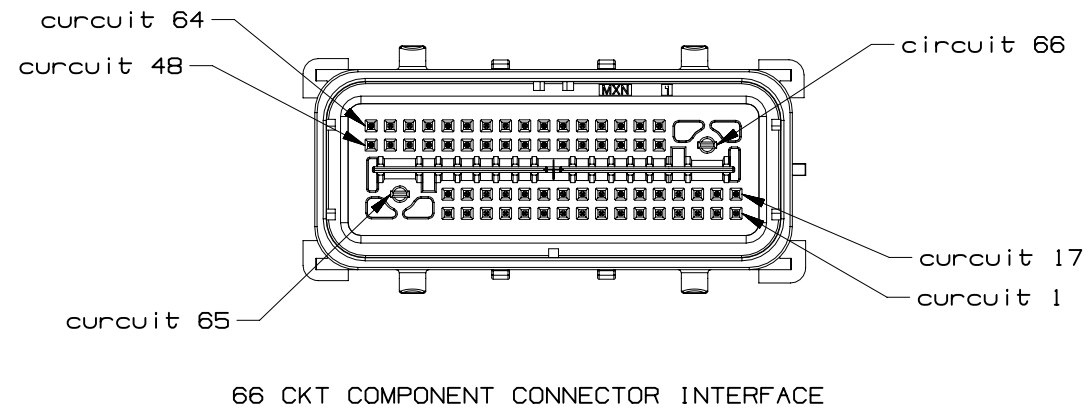
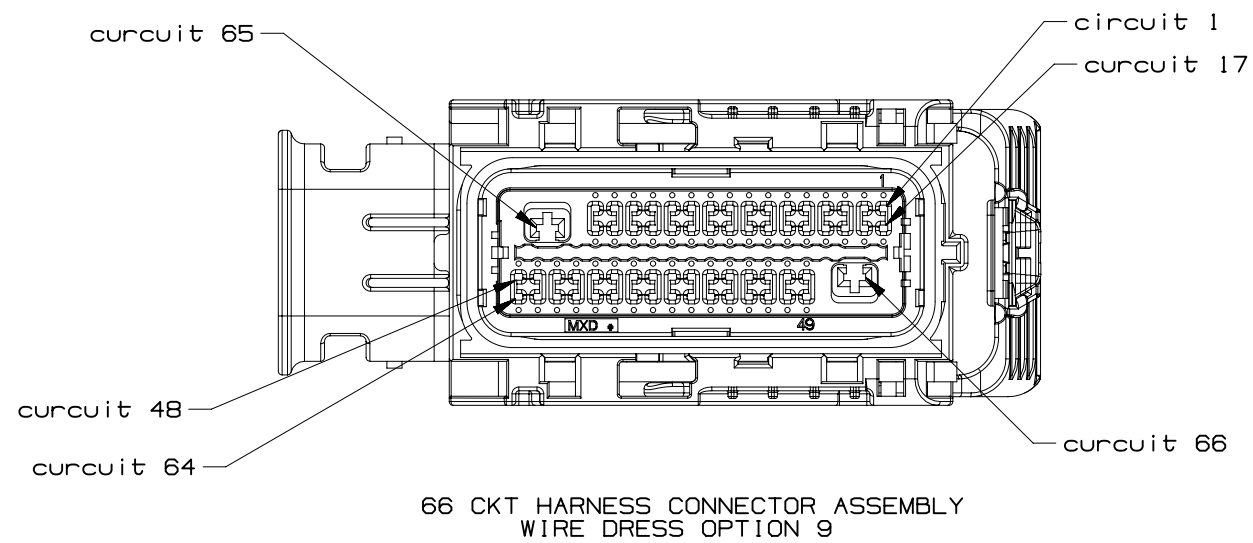
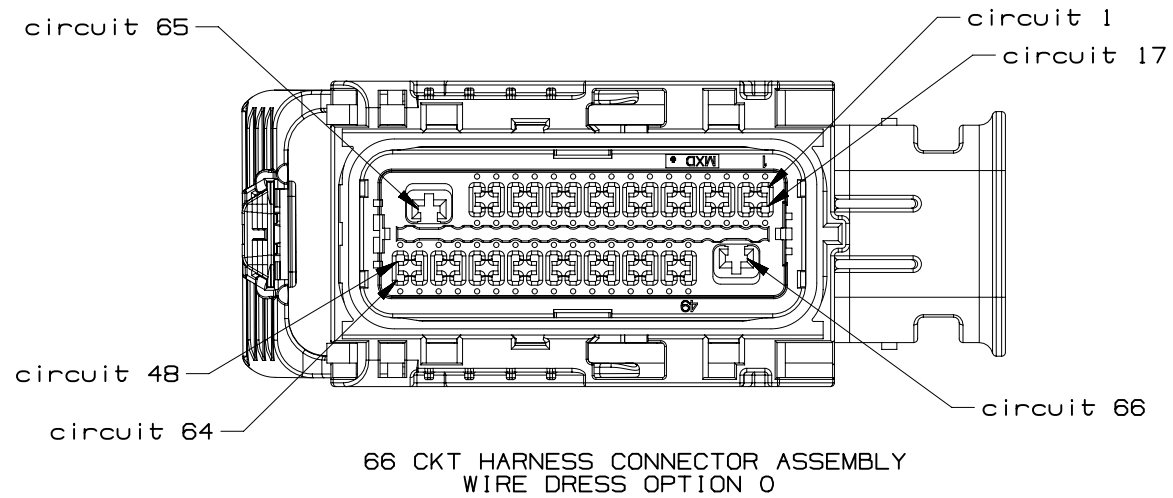



	PAGE TITLE	DRAWING NUMBER	DWG STATUS			PAGE NUMBER	
	CIRCUIT CONFIGURATIONS		12642695	ST	REV	PDI	14 of 21
				R	002		

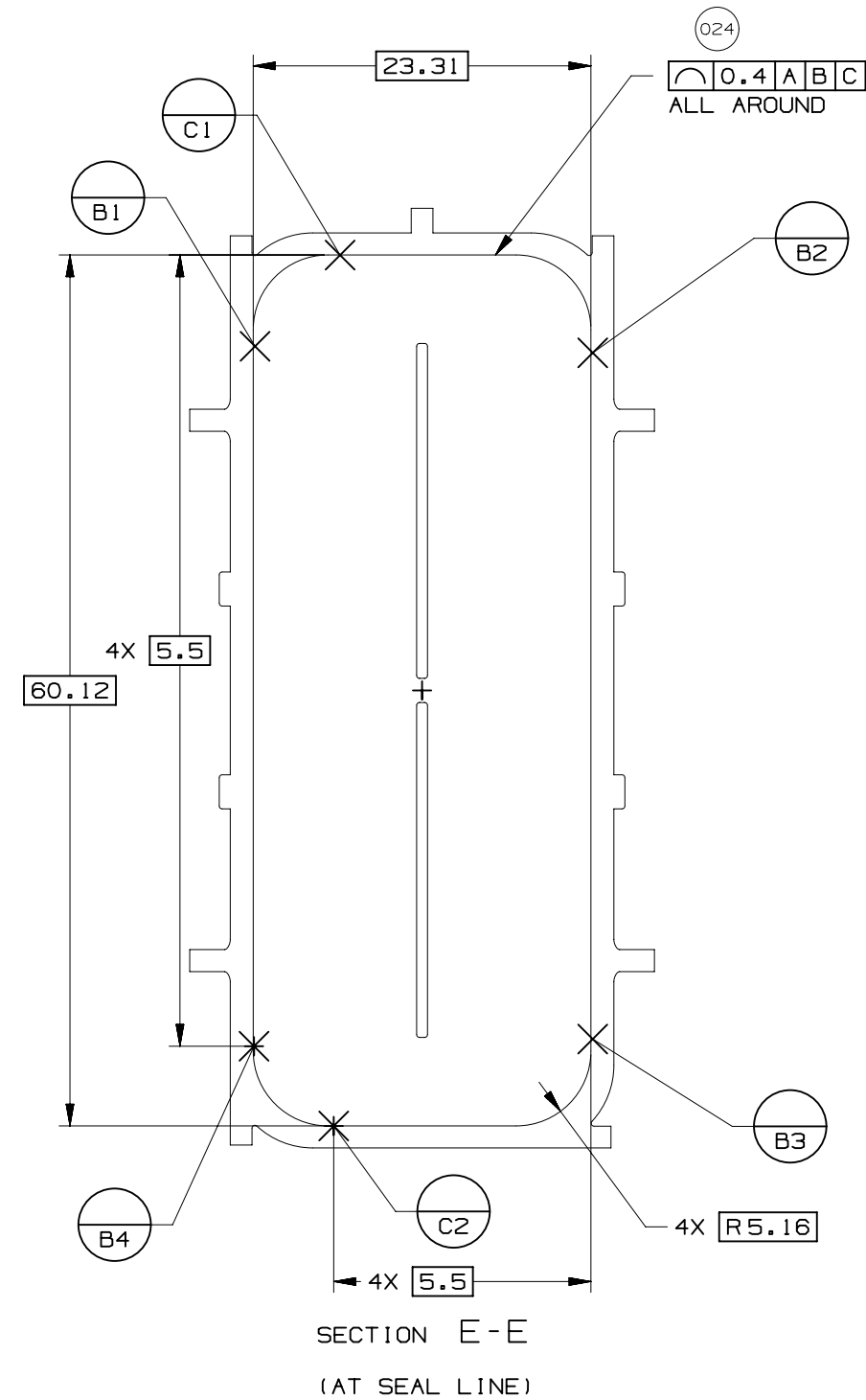
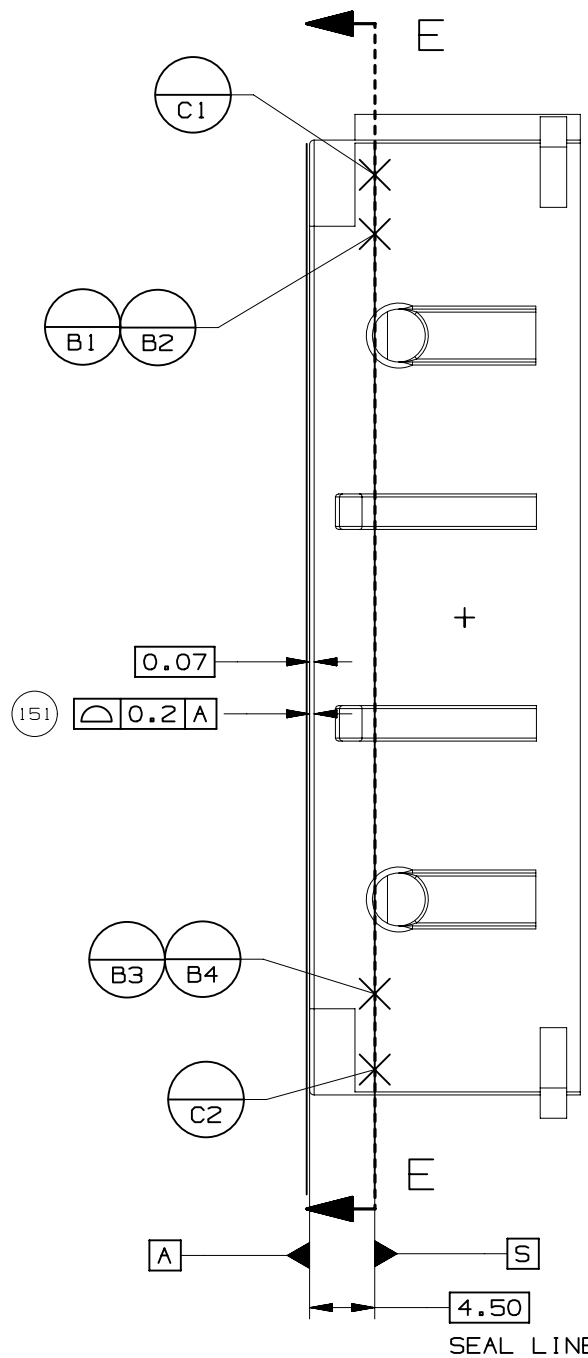
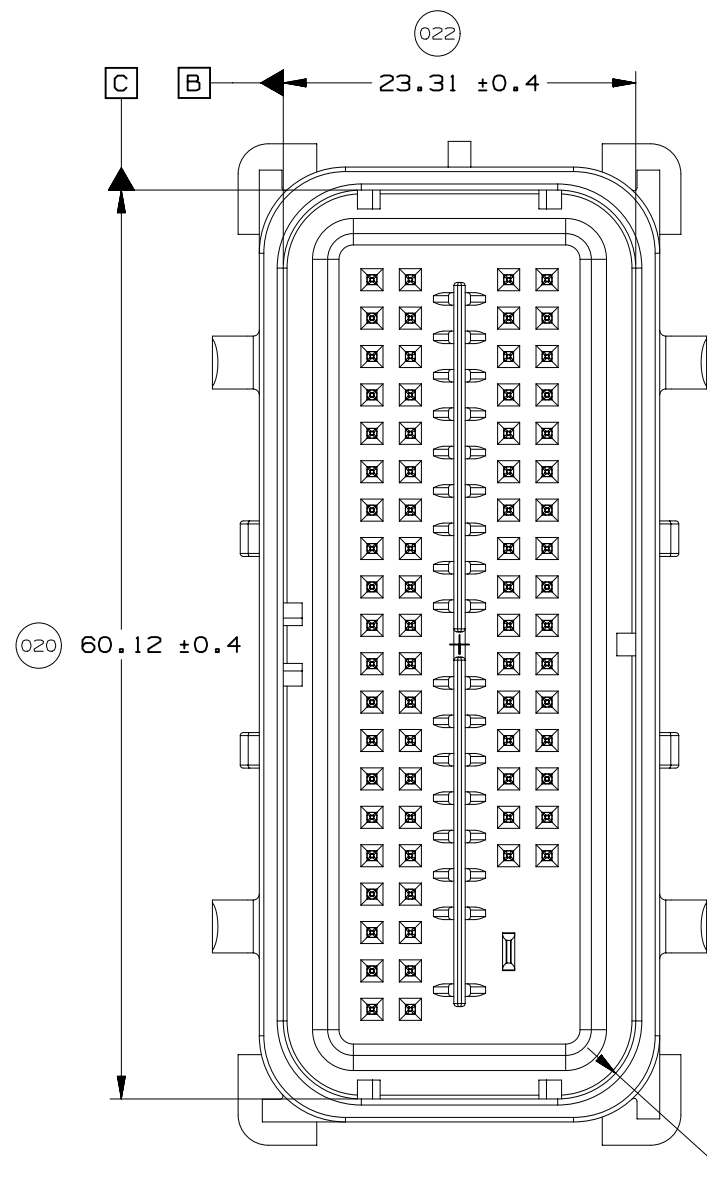
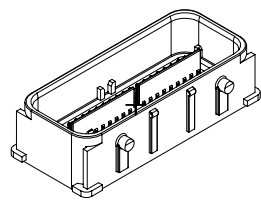

UNLESS SPECIFIED, TOLERANCE OF THE COMPONENT CONNECTOR INTERFACE TO BE  $\sqrt[0.13]{A B C}$



PAGE TITLE  
COMPONENT CONNECTOR INTERFACE

DRAWING NUMBER  
12642695

DWG STATUS			PAGE NUMBER
ST	REV	PD1	
R	002		15 OF 21

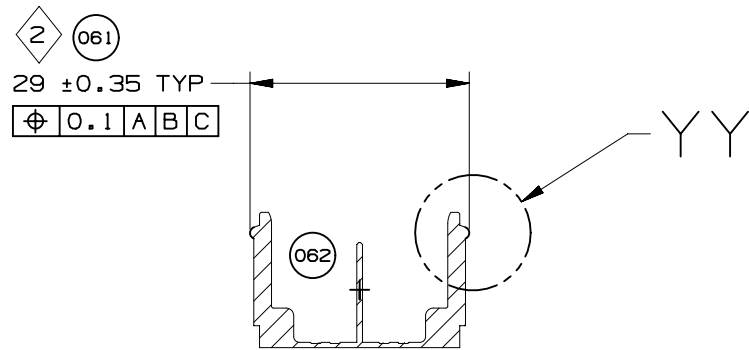
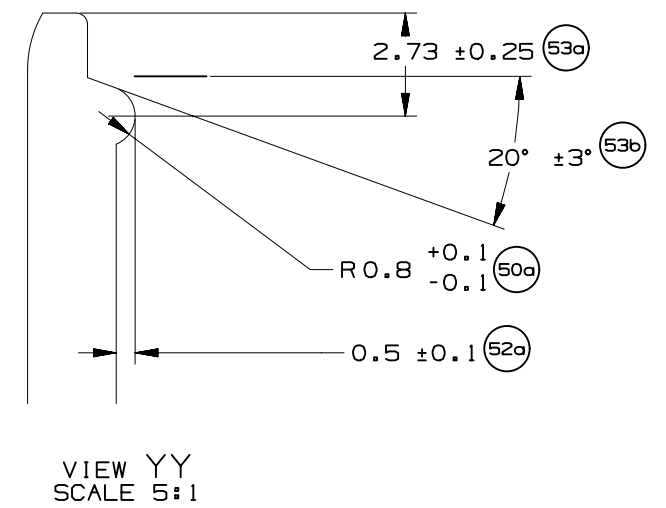
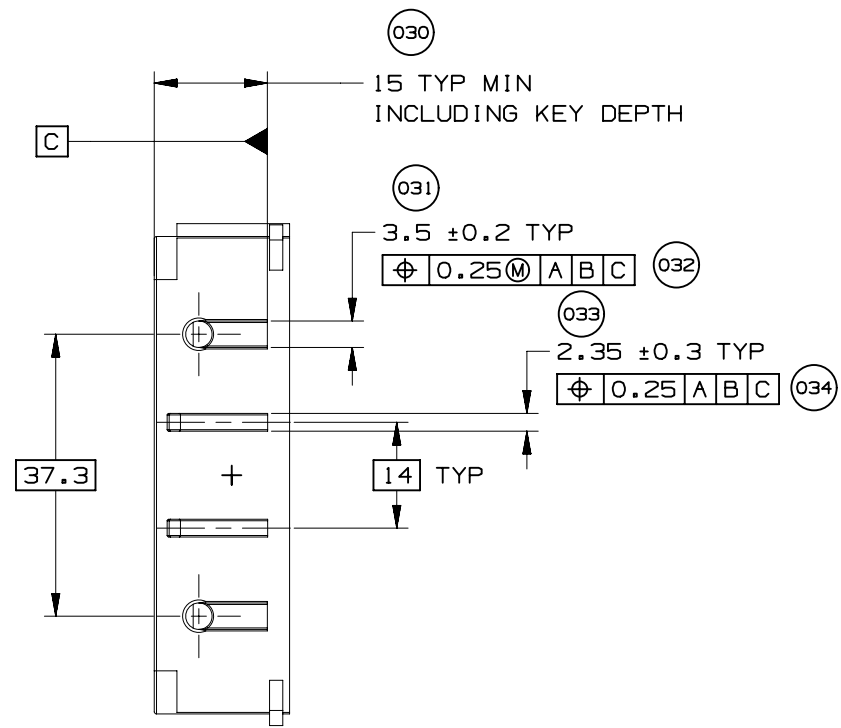
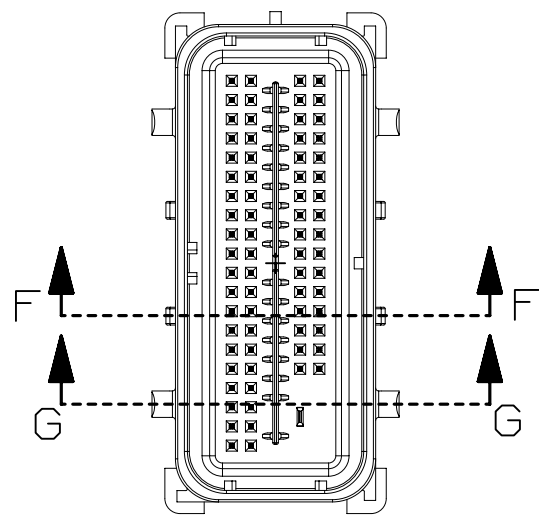

SECTION F-F

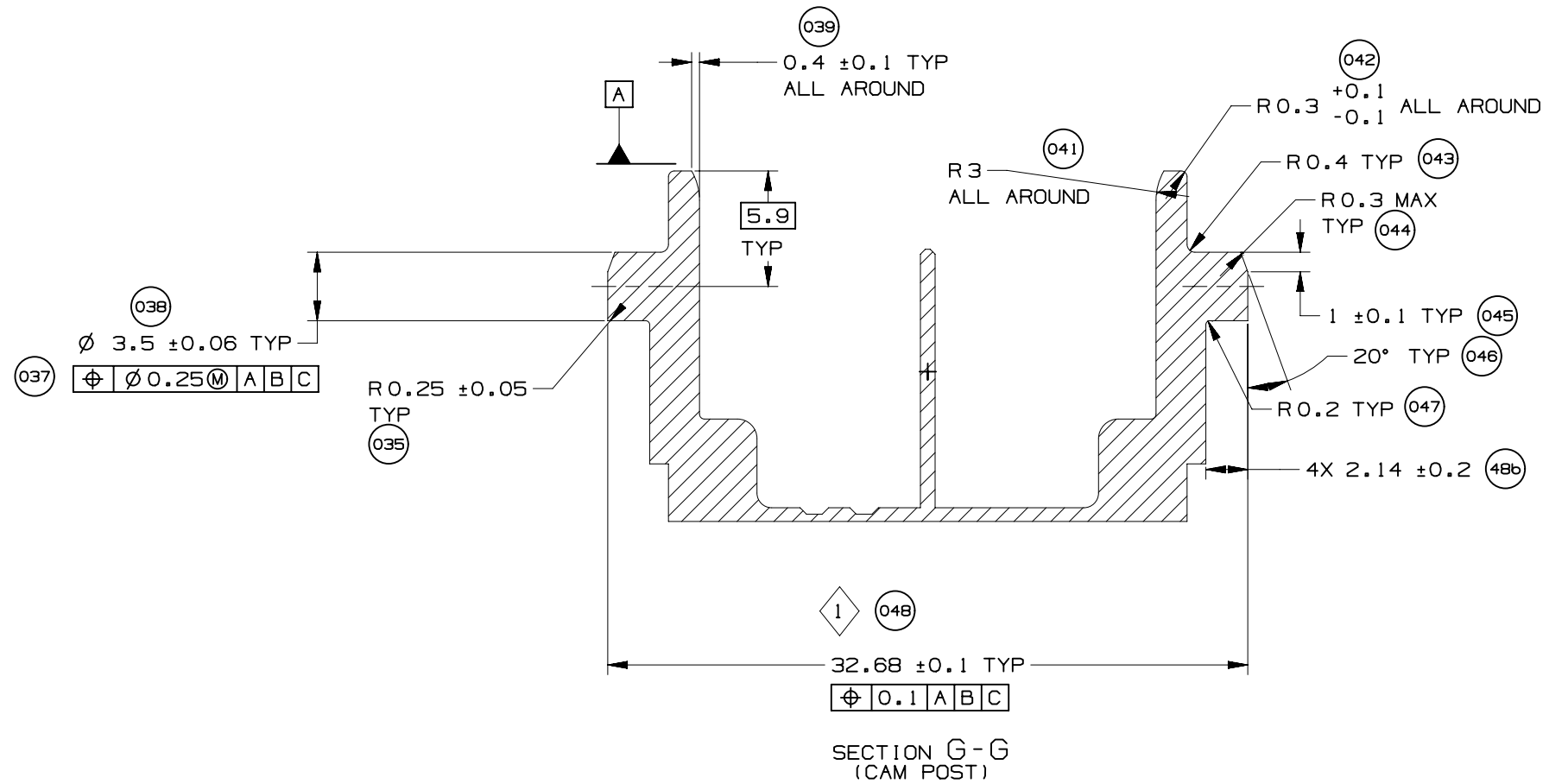

SECTION G-G (CAM POST)



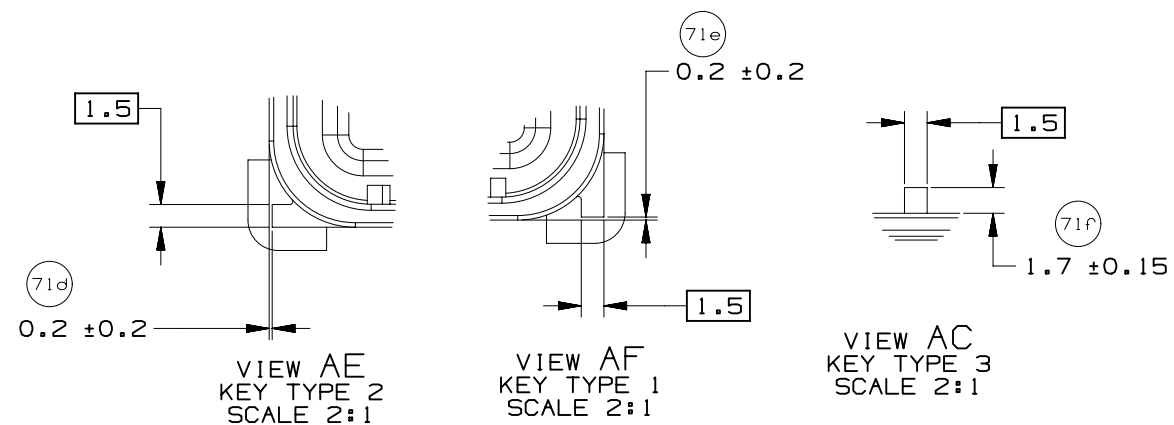
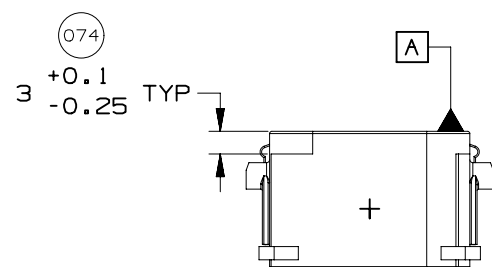
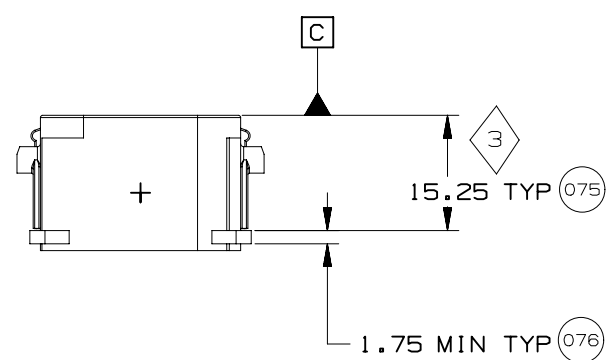
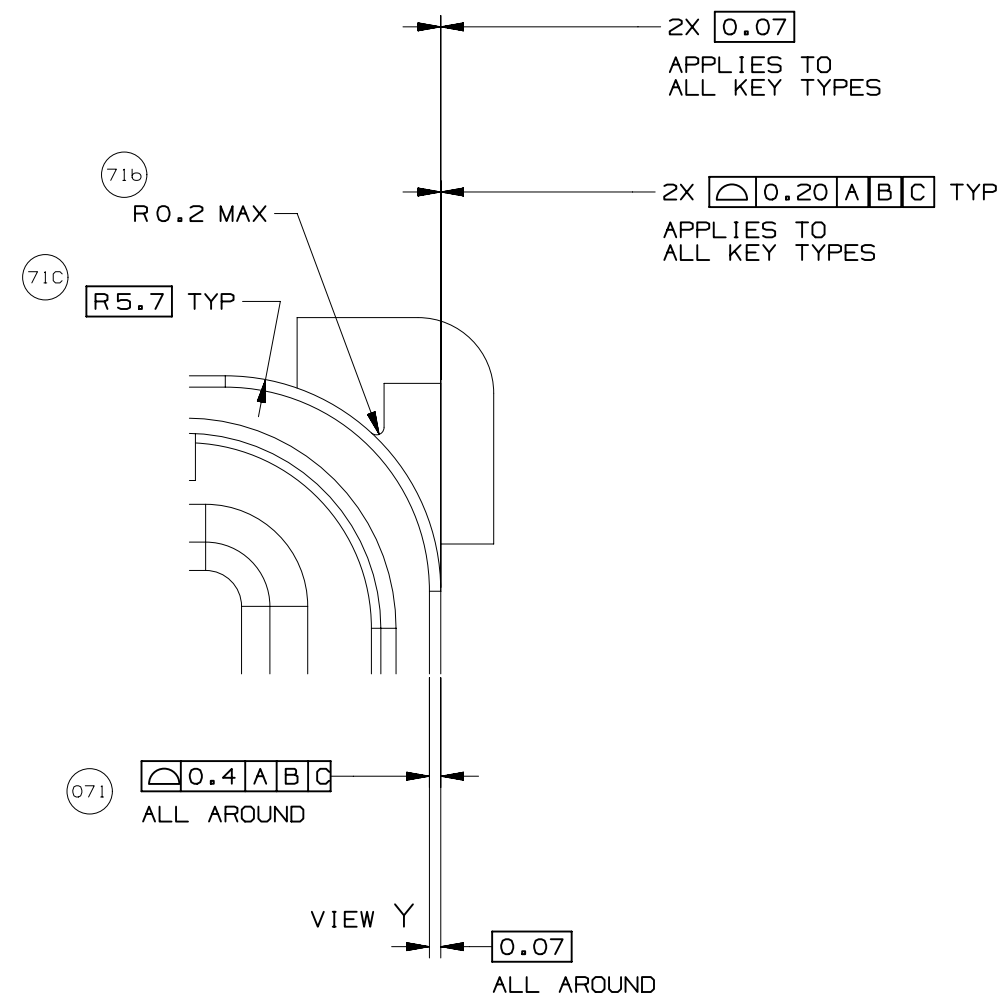
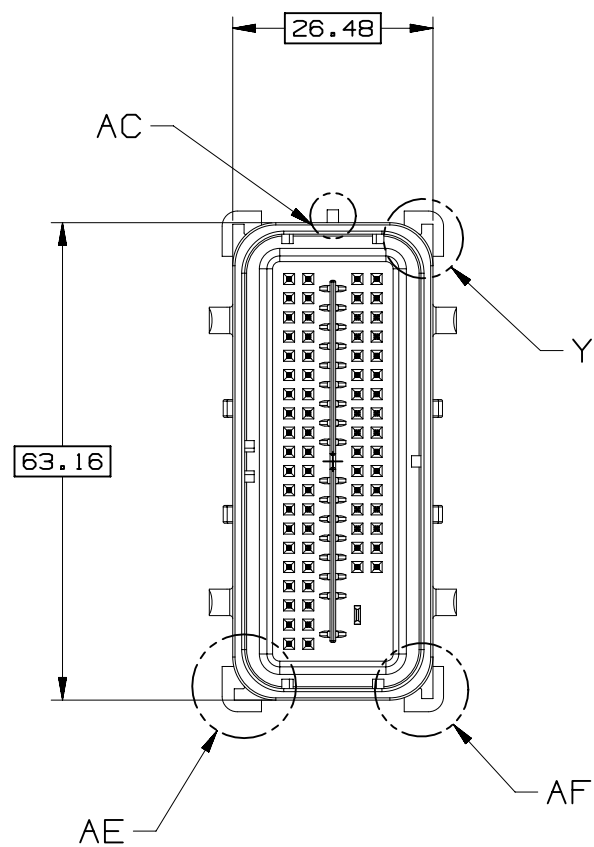
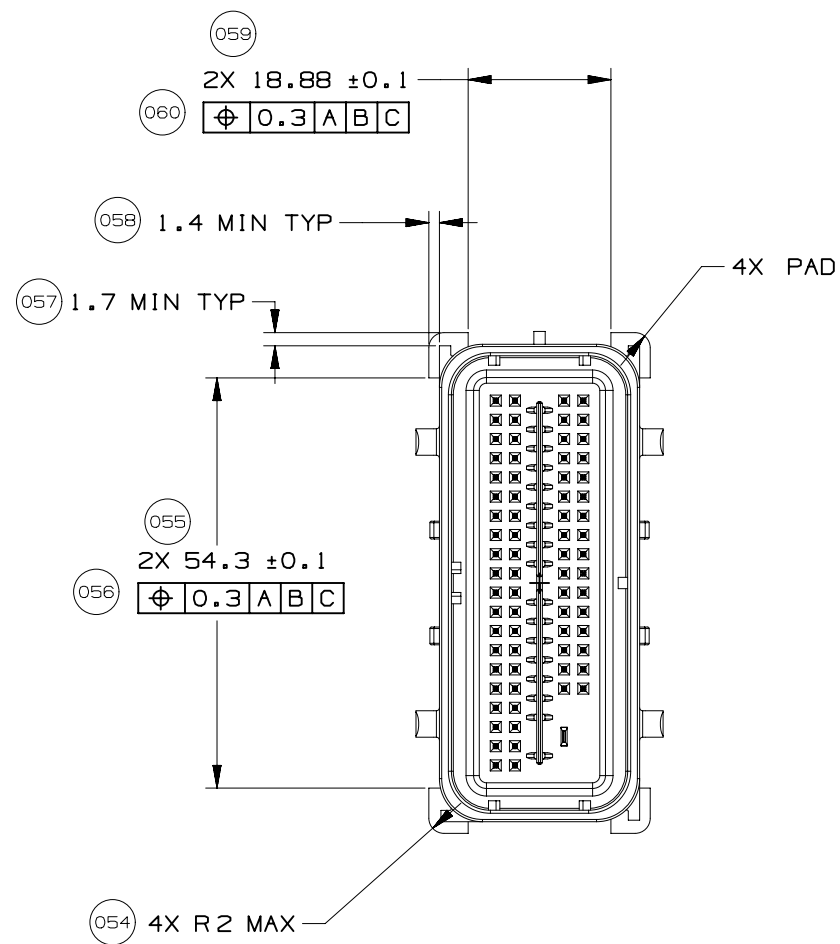

PAGE TITLE  
 COMPONENT CONNECTOR INTERFACE

DRAWING NUMBER  
 12642695

DWG STATUS			PAGE NUMBER	
ST	REV	PD1		
R	002		17	OF 21



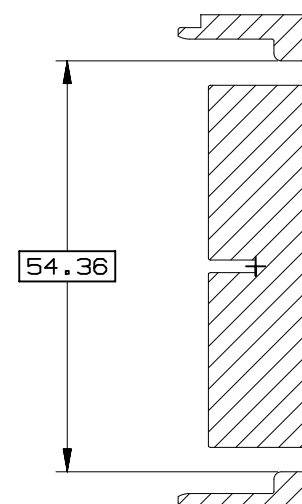
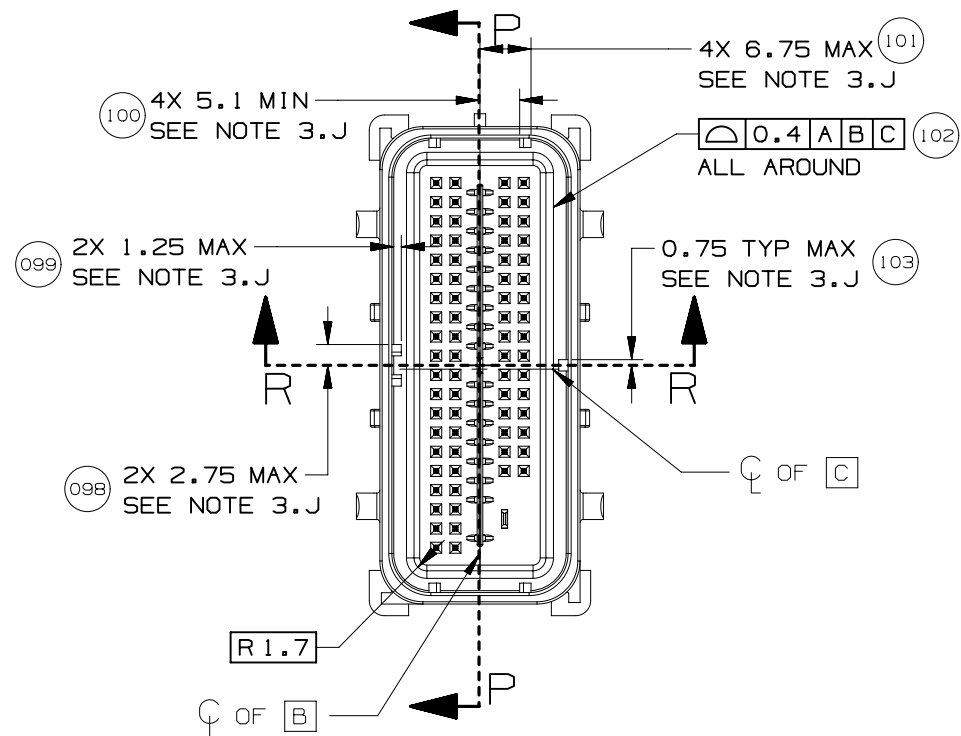

SECTION P-P

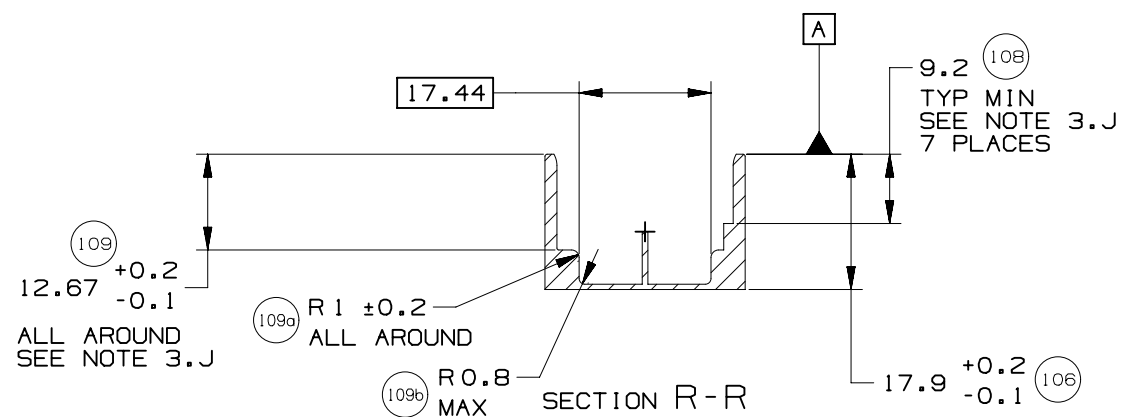

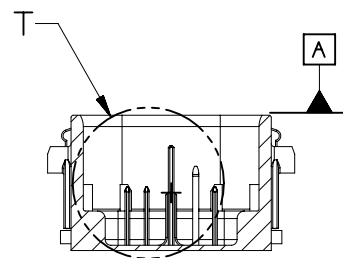
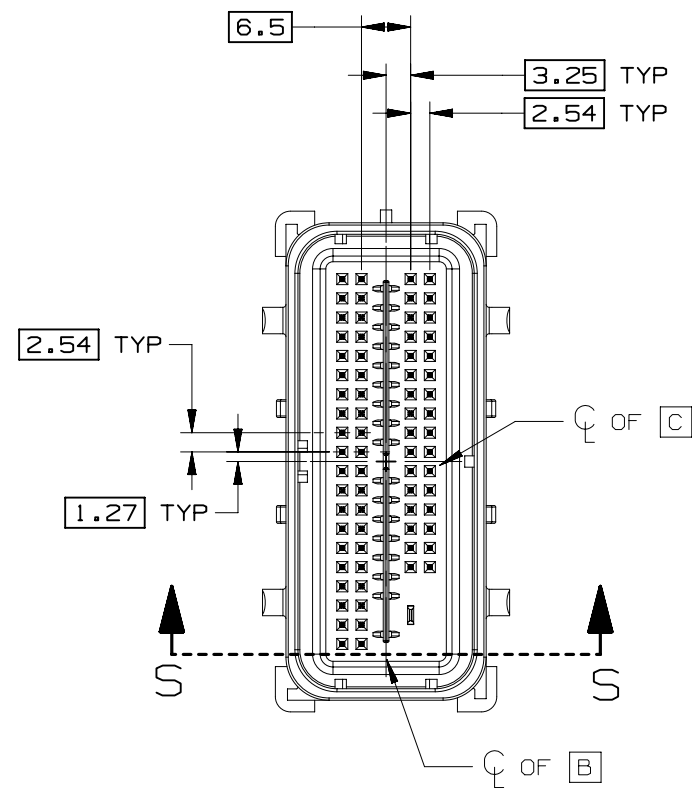

SECTION S-S

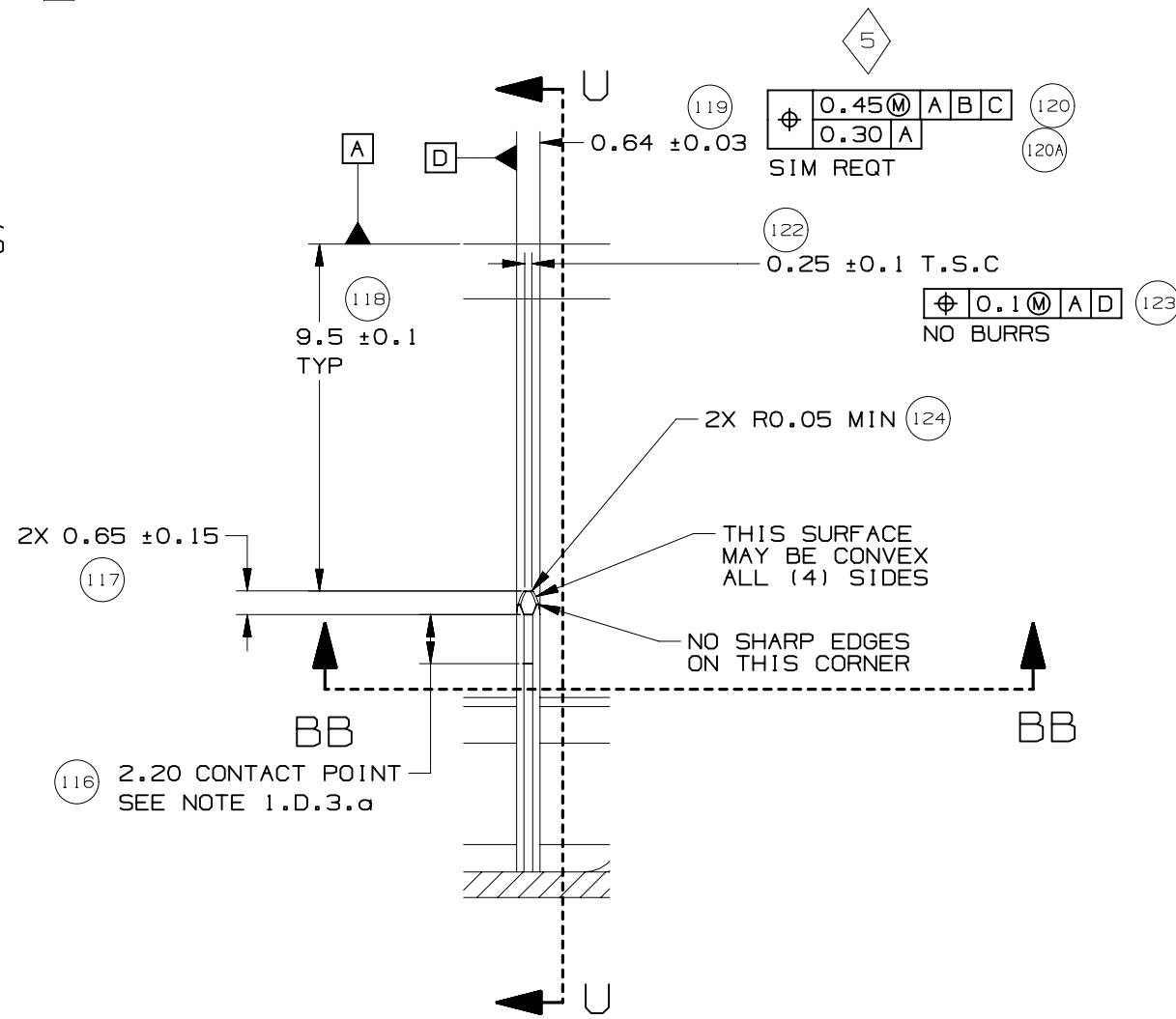

DETAIL T  
TYPICAL  
SCALE 5:1

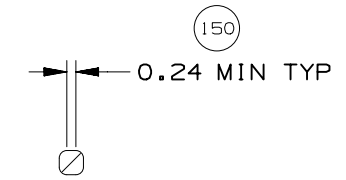

SECTION BB-BB

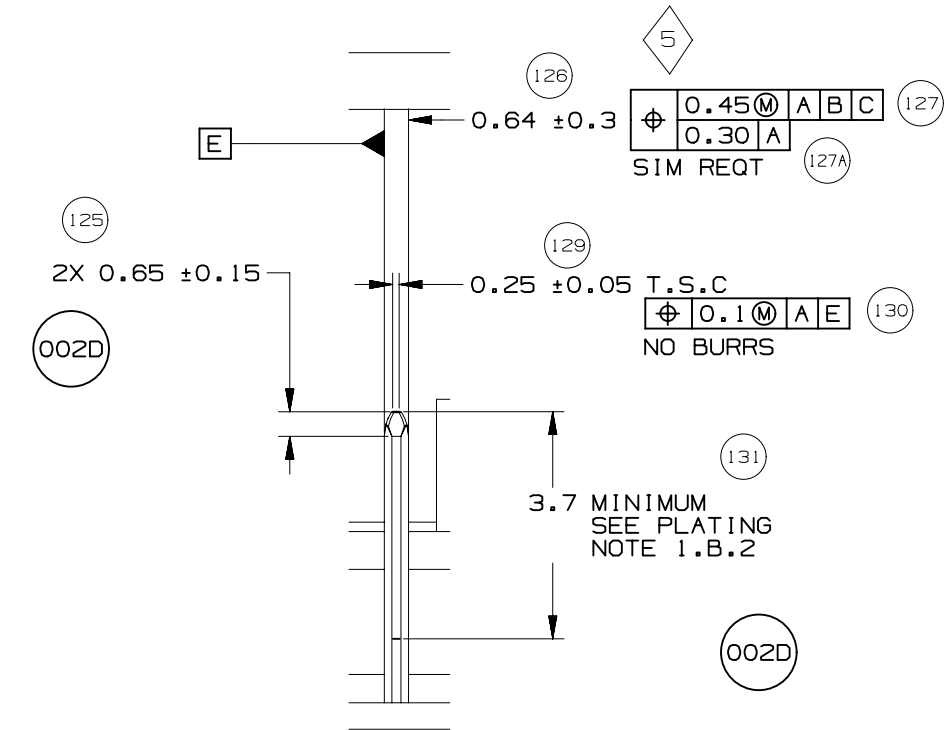

SECTION U-U



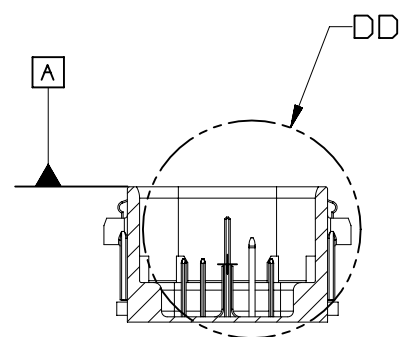
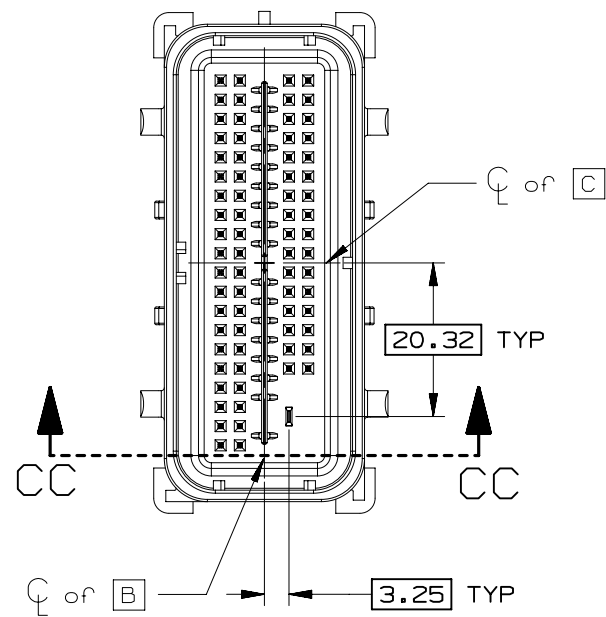

SECTION CC-CC

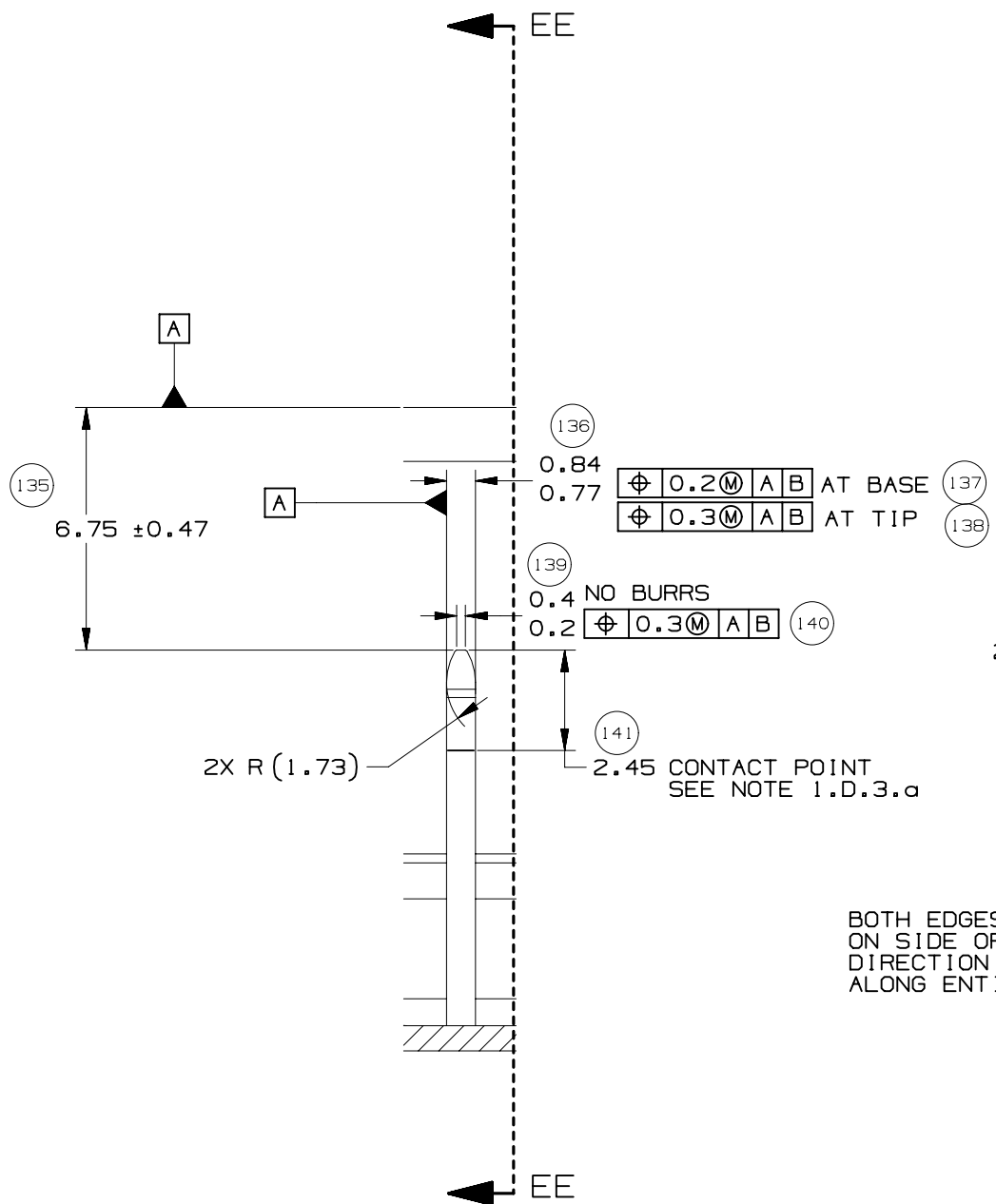

DETAIL DD  
TYPICAL  
SCALE 5:1

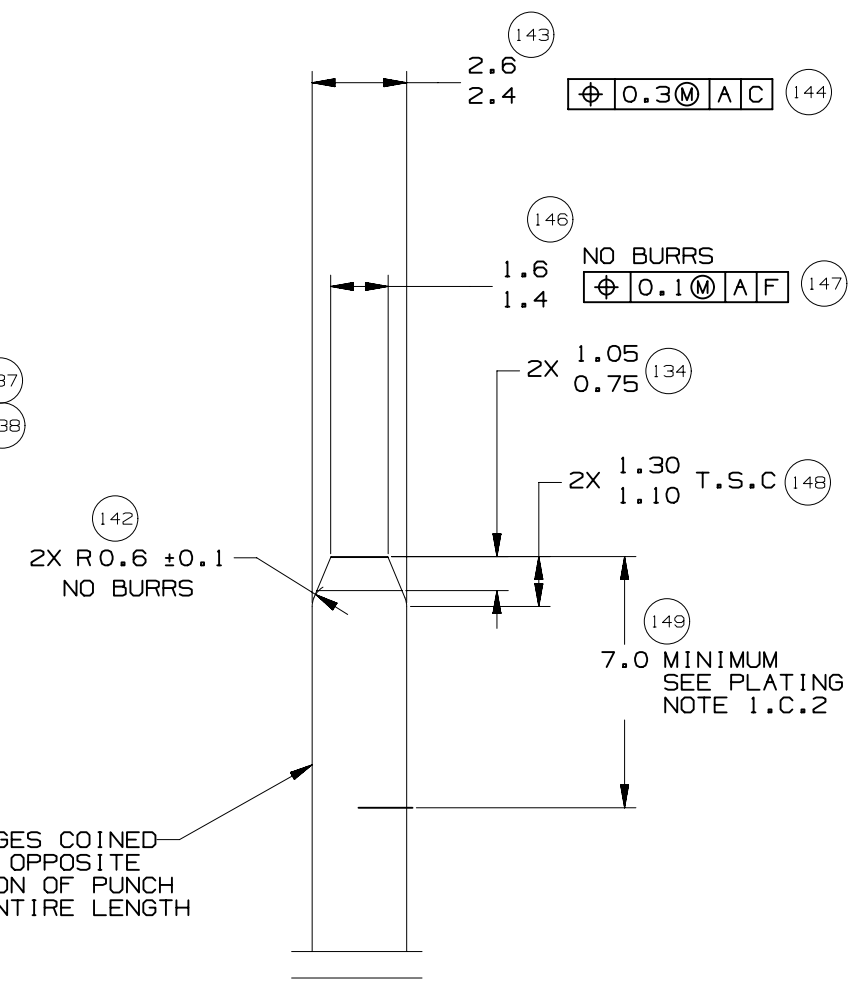

SECTION EE-EE  
TYPICAL

INDEX	
PAGE TITLE	PAGE
TITLE BLOCK	1
REVISION BLOCK	2
PART BLOCK	3
KPC BLOCK	4
COMPONENT TABLE	5
NOTES	6
NOTES	7
WIRE DRESS PACKAGING DIMENSIONS	8
LOCATION AND PACKAGING DIMENSIONS REFERENCING INTERFACE DATUMS B & C	9
LOCATION AND PACKAGING DIMENSIONS REFERENCING INTERFACE DATUM A	10
KEY ID REF - WIRE DRESS OPTION 0	11
KEY ID REF - WIRE DRESS OPTION 9	12
CIRCUIT CONFIGURATIONS	13
CIRCUIT CONFIGURATIONS	14
COMPONENT CONNECTOR INTERFACE	15
COMPONENT CONNECTOR INTERFACE	16
COMPONENT CONNECTOR INTERFACE	17
COMPONENT CONNECTOR INTERFACE	18
COMPONENT CONNECTOR INTERFACE	19
COMPONENT CONNECTOR INTERFACE	20
COMPONENT CONNECTOR INTERFACE	21
COMPONENT CONNECTOR INTERFACE	22
ADDITIONAL COMPONENTS REQUIRED	23

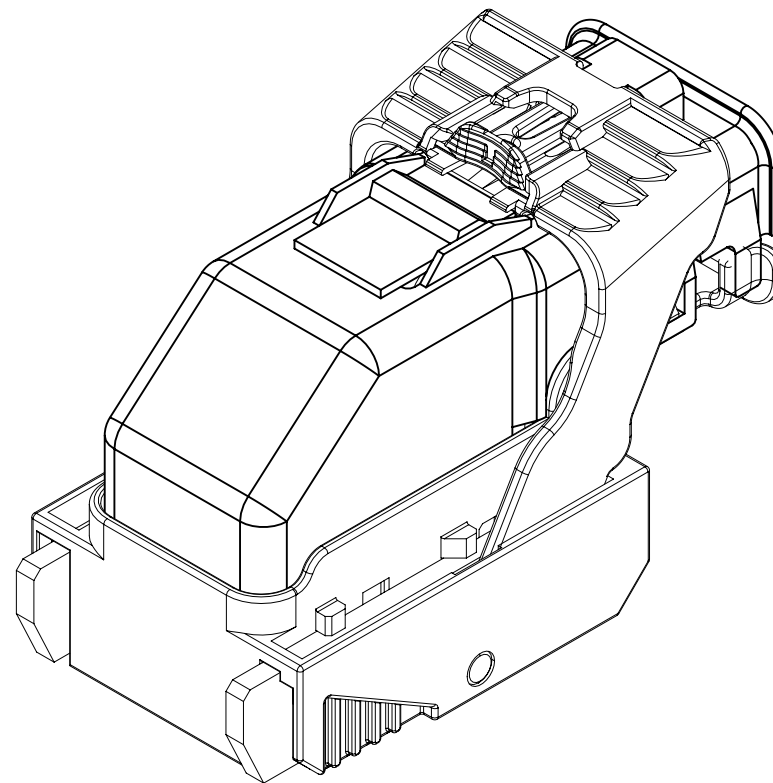

ISO VIEW

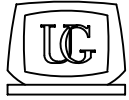
	THIS DOCUMENT IS IN ACCORDANCE WITH ASME Y14.5M-1994 AS AMENDED BY THE GM GLOBAL DIMENSIONING AND TOLERANCING ADDENDUM - 2004.			DATE
	 CHANGE RESTRICTED NO MANUAL CHANGES	REFERENCE 12H (MOLEX AUTOMOTIVE)	DRAFTER D. KOEHLER 04JN15	
DO NOT SCALE	DRAWING NAME HARNESS CONN ASM-SEALED 18/49/56 CKTS, MX123		APVD1	
METRIC		APVD2		
DIMENSIONS SHOWN IN MILLIMETERS UNLESS OTHERWISE SPECIFIED		APVD3		
		APVD4		
		APVD5		
	DRAWING NUMBER	DWG STATUS		PAGE NUMBER
	12672832	ST	REV	PDI
		R	001	1 of 23

PAGE	DWG STATUS					REVISION HISTORY	AUTH	DR	CK	ENG
	DATE	ST	REV	CHG	PDI					

PAGE	DWG STATUS					REVISION HISTORY	AUTH	DR	CK	ENG
	DATE	ST	REV	CHG	PDI					
	03JN15	R	001			RELEASED TO PRODUCTION AT DLS A	CRMRJE	DFK		

	PAGE TITLE	DRAWING NUMBER	DWG STATUS			PAGE NUMBER		
	REVISION BLOCK			12672832	ST		REV	PDI
				R	001			2 of 23





KEY PRODUCT CHARACTERISTICS  
(IN ACCORDANCE WITH QN 1805 OR ON 1050)



SAFETY/COMPLIANCE

TOTAL ON  
DRAWING

4



FIT/FUNCTION

LAST NO.  
USED

4

NO	TYPE	DESCRIPTION	RATIONALE	PAGE/ZONE
1	F/F	32.68	IMPROVE CONNECTOR SYSTEM MATING	16
2	F/F	29.00	INSURE PROPER RELEASE OF LEVER	16
3	F/F	15.25	INSURE FINAL MATE POSITION	17
4	F/F	POSITIONAL TOLERANCE (2 PLACES)	INSURE CONNECTOR SYSTEM MATIBILITY	20



PAGE TITLE  
KPC BLOCK

DRAWING NUMBER

12672832

DWG STATUS

ST	REV	PD1
----	-----	-----

R	001	
---	-----	--

PAGE NUMBER

4 OF 23

Γ J 0	MFG.	MFG. P/N	GM P/N	Effective Date	APPLICABLE COMPONENTS					
					DESCRIPTION	Key Option	Wire Dress Option	Key Config.	Color	Status
1	MOLEX	34575-0003	12582679	02JN03	WIRE HARNESS COVER	N/A	NA	N/A	BLACK	AVAILABLE
2	MOLEX	34851-0007	12672834	31AU15	HARN CONN ASM 18 CKT	G	0	1358	BLUE	ACTIVE
3	MOLEX	34851-0008	12672836	31AU15	HARN CONN ASM 18 CKT	H	0	2458	ST GRAY	ACTIVE
4	MOLEX	34851-0019	12672835	31AU15	HARN CONN ASM 18 CKT	G	9	1358	BLUE	ACTIVE
5	MOLEX	34851-0020	12672837	31AU15	HARN CONN ASM 18 CKT	H	9	2458	ST GRAY	ACTIVE
6	MOLEX	34576-0103	12672838	31JL15	HARN CONN ASM 49 CKT	A	0	1458	BLACK	ACTIVE
7	MOLEX	34576-0203	12672840	T.B.D.	HARN CONN ASM 49 CKT	B	0	1468	ST GRAY	NOT ACTIVE
8	MOLEX	34576-0303	12672842	31JL15	HARN CONN ASM 49 CKT	C	0	2467	BLUE	ACTIVE
9	MOLEX	34576-1303	12672839	31JL15	HARN CONN ASM 49 CKT	A	9	1458	BLACK	ACTIVE
10	MOLEX	34576-1403	12672841	T.B.D.	HARN CONN ASM 49 CKT	B	9	1468	ST GRAY	NOT ACTIVE
11	MOLEX	34576-1503	12672843	31JL15	HARN CONN ASM 49 CKT	C	9	2467	BLUE	ACTIVE
12	MOLEX	34576-0703	12672848	11JN04	HARN CONN ASM 56 CKT	G	0	1358	BLUE	AVAILABLE
13	MOLEX	34576-0803	12672846	11JN04	HARN CONN ASM 56 CKT	H	0	2458	ST GRAY	AVAILABLE
14	MOLEX	34576-0903	12672844	T.B.D.	HARN CONN ASM 56 CKT	J	0	2457	BLACK	NOT ACTIVE
15	MOLEX	34576-1903	12672849	11JN04	HARN CONN ASM 56 CKT	G	9	1358	BLUE	AVAILABLE
16	MOLEX	34576-2003	12672847	T.B.D.	HARN CONN ASM 56 CKT	H	9	2458	ST GRAY	NOT ACTIVE
17	MOLEX	34576-2103	12672845	T.B.D.	HARN CONN ASM 56 CKT	J	9	2457	BLACK	NOT ACTIVE
18	MOLEX	34736-0028	12672851	01AU10	MX64 RCPT TERM Ag 0.5mm/0.75mm ISO GAGE B (RIGHT PAYOFF)	N/A	N/A	N/A	N/A	AVAILABLE
19	MOLEX	34736-0026	12672850	01AU10	MX64 RCPT TERM Ag 0.35mm ISO B (RIGHT PAYOFF)	N/A	N/A	N/A	N/A	AVAILABLE
20	MOLEX	34586-0001	12674820	11JN04	MX123 0.64MM GROMMET PLUG	N/A	N/A	N/A	NATURAL	AVAILABLE
21	YAZAKI	7116-4150-02	12588066	02JN03	2.8mm YESC SEALED FEMALE TERMINAL TIN 0.35mm2-0.50mm2	N/A	N/A	N/A	N/A	NOT ACTIVE
22	YAZAKI	7116-4151-02	12588067	02JN03	2.8mm YESC SEALED FEMALE TERMINAL TIN 0.75mm2-1.0mm2	N/A	N/A	N/A	N/A	NOT ACTIVE
23	YAZAKI	7116-4152-02	12582685	02JN03	2.8mm YESC SEALED FEMALE TERMINAL TIN 1.5mm2-2.5mm2	N/A	N/A	N/A	N/A	AVAILABLE
24	YAZAKI	7158-3111-60	12588068	02JN03	2.8mm CABLE SEAL (wire O.D. range 1.2mm-1.9mm)	N/A	N/A	N/A	GREEN	NOT ACTIVE
25	YAZAKI	7158-3112-70	12588069	02JN03	2.8mm CABLE SEAL (wire O.D. range 1.8mm-2.3mm)	N/A	N/A	N/A	YELLOW	NOT ACTIVE
26	YAZAKI	7158-3113-40	12582686	02JN03	2.8mm CABLE SEAL (wire O.D. range 2.1mm-3.0mm)	N/A	N/A	N/A	WHITE	AVAILABLE
27	YAZAKI	7158-3114-90	12674821	02JN03	2.8mm YESC CAVITY PLUG	N/A	N/A	N/A	BLUE	AVAILABLE
28	DELPHI	33140138	12646399	10JA14	6.35mm APEX RCPT TERM Sn/Ag GRIP CODE-10 (6mm2) - GREASED	N/A	N/A	N/A	N/A	AVAILABLE
29	DELPHI	33140135	12654556	10JA14	6.35mm APEX RCPT TERM Sn/Ag GRIP CODE-TBD (1mm2) - GREASED	N/A	N/A	N/A	N/A	AVAILABLE
30	OSR	A-0549C	12646688	01SE14	6.35mm CABLE SEAL (FOR 6.0mm2 WIRE SIZE - 3.6 TO 4.2mm INSULATION OD)	N/A	N/A	N/A	WHITE	AVAILABLE
31	OSR	A-0549B	12654557	01SE14	6.35mm CABLE SEAL (FOR 0.75-1.25mm2 WIRE SIZE - 1.8 TO 2.3mm INSULATION OD)	N/A	N/A	N/A	BLUE	AVAILABLE
32	MOLEX	63825-8400	N/A	02JN03	MX64 TERM HAND CRIMP TOOL	N/A	N/A	N/A	N/A	AVAILABLE
33	MOLEX	63813-1400	XX019826	02JN03	MX64 TERM SERVICE TOOL	N/A	N/A	N/A	N/A	AVAILABLE
34	MOLEX	63902-5300	N/A	02JN03	MX64 CRIMP APPLICATOR with TOOL KIT 0.5/0.75mm2 PAYOFF DIRECTION D (left payoff) (contact Molex for payoff detail)	N/A	N/A	N/A	N/A	AVAILABLE
35	MOLEX	63902-5370	N/A	02JN03	MX64 APPLICATOR TOOL KIT 0.5/0.75mm2	N/A	N/A	N/A	N/A	AVAILABLE
36	MOLEX	63902-5100	N/A	02JN03	MX64 CRIMP APPLICATOR with TOOL KIT 0.35mm2 PAYOFF DIRECTION D (left payoff) (contact Molex for payoff detail)	N/A	N/A	N/A	N/A	AVAILABLE
37	MOLEX	63902-5170	N/A	02JN03	MX64 APPLICATOR TOOL KIT 0.35mm2	N/A	N/A	N/A	N/A	AVAILABLE
38	SPX	J35616-64	T.B.D.	02JN03	0.64mm PROBE TOOL (for rcpt)	N/A	N/A	N/A	N/A	AVAILABLE
39	SPX	J35616-64A	T.B.D.	02JN03	0.64mm PROBE TOOL WITH EXT (for rcpt)	N/A	N/A	N/A	N/A	AVAILABLE
40	SPX	J35616-65	T.B.D.	02JN03	0.64mm PROBE TOOL WITH EXT (for pin)	N/A	N/A	N/A	N/A	AVAILABLE
41	SPX	J35616-4A	T.B.D.	02JN03	2.8mm PROBE TOOL (for rcpt)	N/A	N/A	N/A	N/A	AVAILABLE
42	YAZAKI	X39899-J374	12094430	02JN03	2.8mm TERM SERVICE TOOL	N/A	N/A	N/A	N/A	AVAILABLE
43	TQI	7000-1001	N/A	01FE15	18CKT PASS THROUGH ADAPTERS	N/A	N/A	N/A	BLACK	AVAILABLE
44	TQI	7000-1004	N/A	01FE15	49CKT PASS THROUGH ADAPTERS	N/A	N/A	N/A	BLACK	AVAILABLE
45	TQI	79917-0060	N/A	02JA08	56CKT PASS THROUGH ADAPTERS	N/A	N/A	N/A	BLACK	AVAILABLE
46	MOLEX	63813-1500	J-38125-217	01SE14	6.35mm APEX TERM SERVICE TOOL	N/A	N/A	N/A	N/A	AVAILABLE

\* MX123 WIRE HARNESS COVER  
MATES TO ANY 18/49/56 CKT  
MX123 HARN CONN ASSY  
SHOWN ON THIS TABLE



PAGE TITLE  
COMPONENT TABLE

DRAWING NUMBER

12672832

DWG STATUS

ST REV PDI

R 001

PAGE NUMBER

5 of 23

NOTES: UNLESS OTHERWISE SPECIFIED

1. MATERIAL FOR INTERFACE:

- A. RESIN:
  - 1. 30% G.F. PBT; 20% MAX. (BY WEIGHT) REGRIND.
  - 2. MATING CONNECTOR INTERFACE PART COLOR MUST BE SAME AS MATCHING KEYED HARNESS CONNECTOR ASSEMBLY.
  - 3. MUST BE VALIDATED FOR INDIVIDUAL DEVICE APPLICATION REQUIREMENTS.
- B. 0.64MM PINS:
  - 1. BASE MATERIAL: COPPER ALLOY; CONDUCTIVITY >= 28% IACS AT 20°C; TENSILE STRENGTH >= 635 N/mm<sup>2</sup>; SURFACE ROUGHNESS R<sub>a</sub> 6 MAX.
  - 2. PLATING FINISH: SILVER (Ag). PLATING TO BE 1.9-3.3 μm ELECTRODEPOSITED SEMI-BRIGHT SILVER OVER 1.25-2.25 μm DUCTILE SULPHAMATE NICKEL PER NOTE 1(D).
  - 3. ANTI-TARNISH: SYNTHETIC HYDROCARBON CONTACT SURFACE FINISH OR EQUIVALENT APPLIED WITHOUT VOID TO CONTACT AREA (MIN 3.7mm FROM PIN TIP).
- C. 2.8MM BLADE:
  - 1. BASE MATERIAL: COPPER ALLOY; CONDUCTIVITY >= 28% IACS AT 20°C; TENSILE STRENGTH >= 350 N/mm<sup>2</sup>; SURFACE ROUGHNESS R<sub>a</sub> 6 MAX.
  - 2. PLATING FINISH: TIN. PLATING TO BE 2.5-5.0 μm ELECTRODEPOSITED TIN, MATTE FINISH OVER 1.25-2.5μm DUCTILE SULPHAMATE NICKEL PER NOTE 1(D).
- D. 6.3MM BLADE:
  - 1. BASE MATERIAL: COPPER ALLOY; CONDUCTIVITY >= 50% IACS AT 20°C;
  - 2. PLATING FINISH: SILVER (Ag) PLATING TO BE 1.9-3.3 μm ELECTRODEPOSITED SEMI-BRIGHT SILVER, OVER 1.25-2.5μm DUCTILE SULPHAMATE NICKEL PER NOTE 1(D) WITH ENVIRONMENTAL BARRIER OR TIN/SILVER (ELECTRO-DEPOSITED), UNDERPLATE 0.5-2.0 μm NICKEL OR COPPER. TOP PLATING: 1.0-3.0 μm (SILVER RANGE 3.75-X.XX NO ANTI-TARNISH COATING REQUIRED).
- E. PLATING REQUIREMENTS:
  - 1. SILVER PLATING
    - a. 99.5% PURE SEMI-BRIGHT WITH NO ORGANIC BRIGHTNERS OR CHROMATES.
  - 2. NICKEL PLATING
    - a. ELECTRODEPOSITED DUCTILE SULFAMATE NICKEL WITH A NON-BRIGHTENED FINISH. NO ORGANIC OR BRIGHTENING AGENTS SHALL BE ALLOWED.
    - b. SHALL ONLY BE USED AS AN UNDERLYING PLATING AND MAY NOT BE USED AS AN ELECTRICAL CONTACT SURFACE PLATING.
    - c. SHALL BE NODULE FREE WHEN VIEWED AT 10X MAGNIFICATION IN MEASURED IN CONTACT SURFACE AREA PLUS 0.5MM PERIMETER AROUND THE CONTACT SURFACE AREA.
    - d. ALL PLATINGS SHALL HAVE A 1.0% MAXIMUM BY WEIGHT IMPURITIES. IMPURITIES ARE DEFINED AS ALL ELEMENTS NOT THE PRIMARY PLATING OR HARDENING AGENT IF APPLICABLE, AS DETERMINED BY WET CHEMICAL ANALYSIS OR AUGER METHOD. NO SINGLE IMPURITY SHALL EXCEED 0.1% MAXIMUM BY WEIGHT.
  - 3. TESTING
    - a. THICKNESS TO BE MEASURED IN CONTACT SURFACE AREA PLUS 0.5MM PERIMETER AROUND THE CONTACT SURFACE AREA AS DESIGNATED IN THE DRAWING. THICKNESS SHALL BE DETERMINED BY METHOD OF X-RAY (XRF).
    - b. PLATING ADHESION SHALL BE TESTED BY A BEND TEST FOR ALL METALS. THE TEST SAMPLE SHALL BE BENT 90 DEGREES TO DETERMINE DEPOSIT ADHESION. TESTING SHALL BE COMPLETED IN ACCORDANCE WITH ASTM SPEC B571.

2. DESIGN - GENERAL:

- A. THIS IS A 100% CAD GENERATED PART. THE CAD MATHEMATICAL DATA IS THE MASTER FOR THIS PART. WHERE DIMENSIONS ARE SPECIFIED ON THE DRAWING, THE DRAWING IS THE AUTHORITY FOR DIMENSIONAL VALUES. FOR DIMENSIONAL OR ANY INFORMATION NOT SHOWN ON THIS DRAWING, ANALYZE THE CAD MODEL.
- B. DIMENSIONS OBTAINED FROM THE DIGITAL MODEL ARE BASIC:
  - 1. FOR RELATIONSHIPS BETWEEN FEATURES WHEN ESTABLISHED BY GEOMETRIC TOLERANCES.
  - 2. FOR THE FORM OF A FEATURE WHEN CONTROLLED BY A PROFILE TOLERANCE.
  - 3. FOR THE SIZE, FORM AND/OR RELATIONSHIP BETWEEN FIXED DATUM TARGETS.
- C. DIMENSIONS OBTAINED FROM THE DIGITAL MODEL ARE ROUNDED TO TWO DECIMAL PLACES (PER IEEE/ASTM SI 10-2002)
- D. VIEWS AND SECTIONS ON THIS DRAWING ARE IN ACCORDANCE WITH GM DCS SECTION C3.
- E. THE DIGITAL MODEL MUST CORRESPOND TO THE RELEASE LEVEL SHOWN IN THE PART BLOCK ON THIS DOCUMENT.
- F. TOLERANCES:
  - 1. LINEAR
 

0.X	± 0.30
0.XX	± 0.10
0.XXX	± 0.10
  - 2. ANGULAR
 

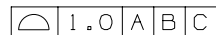
X°	± 3°
----	------
  - 3. 
- G. MINIMUM WALL THICKNESS REQUIRED: 1.3mm.
- H. CORNERS SHOWN AS SHARP TO BE R 0.2 MAX.
- J. LETTERING SHALL BE 0.15 MAX RAISED IN 0.20 MAX RECESS PAD. THIS INCLUDES MATERIAL CODE, RECYCLING CODE, CAVITY ID AND DATE CODE.
- K-1. PARTS MUST BE FREE OF DISCOLORATION, SALT RESIDUE AND OTHER IMPERFECTIONS THAT AFFECT FIT OR FUNCTION.
- K-2. SCRATCHES OR DENTS NOT TO EXCEED 0.013mm IN DEPTH.
- L. FOLLOWING PRODUCTION CODES TO BE PERMANENTLY MARKED & HUMAN READABLE TO A LETTER HEIGHT OF 1.5 ±0.5MM X 0.3 MAX DEEP
  - 1. MATERIAL #: XXXXX-XXXX
  - 2. DATE CODE: JJJY (JULIAN DAY, LAST DIGIT OF YEAR)
  - 3. INSPECTION MACHINE CODE + SERIAL #: X\_XXXXXX

3. DESIGN - MANUFACTURING:

- A. DRAFT TO BE WITHIN TOLERANCE.
- B. ALLOWABLE FLASH MAX 0.2 HIGH X MAX 0.13 THICK.
- C. ALLOWABLE PARTING LINE MISMATCH 0.2 MAX.
- D. EJECTOR PINS MARK TO BE FLUSH TO 0.25 MAX DEPRESSED.
- E. ALLOWABLE GATE VESTIGE FLUSH TO 0.25 MAX PROTRUSION.
- F. NO EXTERNAL MOLD RELEASE AGENT ALLOWED DURING MANUFACTURING.
- G. STEEL THAT FORMS THE INDICATED SURFACE MUST BE POLISHED WITH A DIAMOND FINISH (SPI A-2) OVER THE FULL PERIPHERY OF THE TOOL. SURFACE MUST HAVE NO MISMATCH.
- H. ANY PROCESS LUBRICANT REMAINING ON THE TERMINAL MUST NOT VARNISH OR DEGRADE IT'S ELECTRICAL PERFORMANCE UP TO A MAXIMUM CLASS AMBIENT TEMPERATURE PER SAE USCAR-2 FOR 1008 HOURS. PROCESS LUBRICANTS SHOULD BE APPROVED BY THE RESPONSIBLE ENGINEER.
- J. OPTIONAL FEATURES PROVIDED FOR AUTOMATION.
- K. PART MUST BE FREE FROM BURRS AND SHARP EDGES, WHICH MIGHT BE DETRIMENTAL TO SATISFACTORY ASSEMBLY, SAFE HANDLING OR FUNCTION OF PART.
- L. PARTS AS DELIVERED TO ASSEMBLY SHALL BE CLEAN AND FREE OF DEBRIS, RESIDUAL ABRASIVE MATERIAL AND CORROSION PRODUCTS ADVERESLY AFFECTING FUNCTION OR APPEARANCE.
- M. RESTRICTED AND REPORTABLE SUBSTANCES FOR PARTS PER GMW3059.

	PAGE TITLE	DRAWING NUMBER	DWG STATUS			PAGE NUMBER	
	NOTES		12672832	ST	REV		PDI
				R	001		

NOTES: UNLESS OTHERWISE SPECIFIED

4. SYSTEM REQUIREMENTS:

- A. HARNESS CONNECTOR IS COMPATIBLE WITH THE FOLLOWING WIRE SIZE NO'S:  
 0.35mm<sup>2</sup>, MEETING GMW15626 - MIN OD OF 1.30MM  
 0.50mm<sup>2</sup>, MEETING GMW15626  
 0.75mm<sup>2</sup>, MEETING GMW15626 - MIN OD OF 2.06MM

B. CABLE TIE SPECIFICATIONS:

1. CABLE TIE:  
 TENSILE RATING: 220N / (50lbs) MIN  
 TIE LENGTH: 186mm MIN  
 TIE WIDTH: 4.75mm MAX  
 MATERIAL: NYLON
2. INSTALLATION:  
 CABLE TIE TENSION: 190N MIN
3. DRESSED WIRE BUNDLE PACKAGING: SEE FIG. 1

C. WHEN MATED WITH COMPONENT CONNECTOR INTERFACE AND/OR DRESS COVER, HARNESS CONNECTOR SYSTEM CONFORMS TO THE FOLLOWING:

1. SAE/USCAR-2, REV: 3 APRIL, 2001; CLASS 3
2. FIELD CORRELATED LIFE TEST, SAE/USCAR-20, NOV. 2001
3. GMW #3191 AUGUST 22, 2000 (DRAFT); TEMPERATURE CLASS 3 (145°C), SEALING CLASS 1 (HIGH PRESSURE SPRAY), VIBRATION CLASS 2 (ON BODY)
4. TPA USER FORCES (FULLY POPULATED WITH TERMINALS)
  - α. REMOVAL FROM LOCK TO PRE-SET: <=120N

D. WIRE SPECIFICATIONS:

1. WIRE SURFACE MUST BE FREE OF SCRATCHES, GROOVES OR DENTS WHERE FUNCTIONAL

5. TERMINAL CURRENT RATINGS:

A. MX64 RCPT TERM

ALL TESTING DONE IN ACCORDANCE WITH USCAR-2 REV5 SECTION 5.3

1. MX64 RCPT TERM Ag 0.50/0.75mm<sup>2</sup> CRIMPED TO 0.75mm<sup>2</sup> ISO WIRE AND MATED TO MX123 0.64MM PIN: SEE TABLE BELOW
2. MX64 RCPT TERM Ag 0.35mm<sup>2</sup> CRIMPED TO 0.35mm<sup>2</sup> ISO WIRE AND MATED TO MX123 0.64MM PIN: SEE TABLE BELOW

WIRE	CURRENT RATING			
	23 °C	85 °C	105 °C	125 °C
0.75mm <sup>2</sup>	11.3A	11.3A	9.5A	6.6A
0.50mm <sup>2</sup>	10.0A	10.0A	8.3A	5.7A
0.35mm <sup>2</sup>	8.5A	8.5A	7.1A	5.0A

B. 2.8MM RCPT TERM

ALL TESTING DONE IN ACCORDANCE WITH MOLEX DVP&R 0279 (TR# 7125)

1. 2.8MM RCPT TERM TIN 2.0mm<sup>2</sup> CRIMPED TO 2.0mm<sup>2</sup> ISO WIRE AND MATED TO MX123 2.8MM BLADE: 25.6 AMPS AT 125°C

C. 6.3MM RCPT TERM - DELPHI APEX

ALL TESTING DONE IN ACCORDANCE WITH USCAR-2 REV5 SECTION 5.3

1. 6.3MM RCPT TERM TIN/SILVER CRIMPED TO 6.0MM<sup>2</sup> WIRE AND MATED TO MOLEX 6.3MM<sup>2</sup> BLADE (Sn/Ag PLATED): 36A AT 125°C

6. CONTACT MOLEX AUTOMOTIVE FOR AVAILABLE CUSTOM PATTERNS OF CAVITIES OPEN FOR CIRCUITS - SEE GM DRAWING 13507495



PAGE TITLE  
NOTES

DRAWING NUMBER

12672832

DWG STATUS

ST	REV	PDI
R	001	

PAGE NUMBER

7 of 23

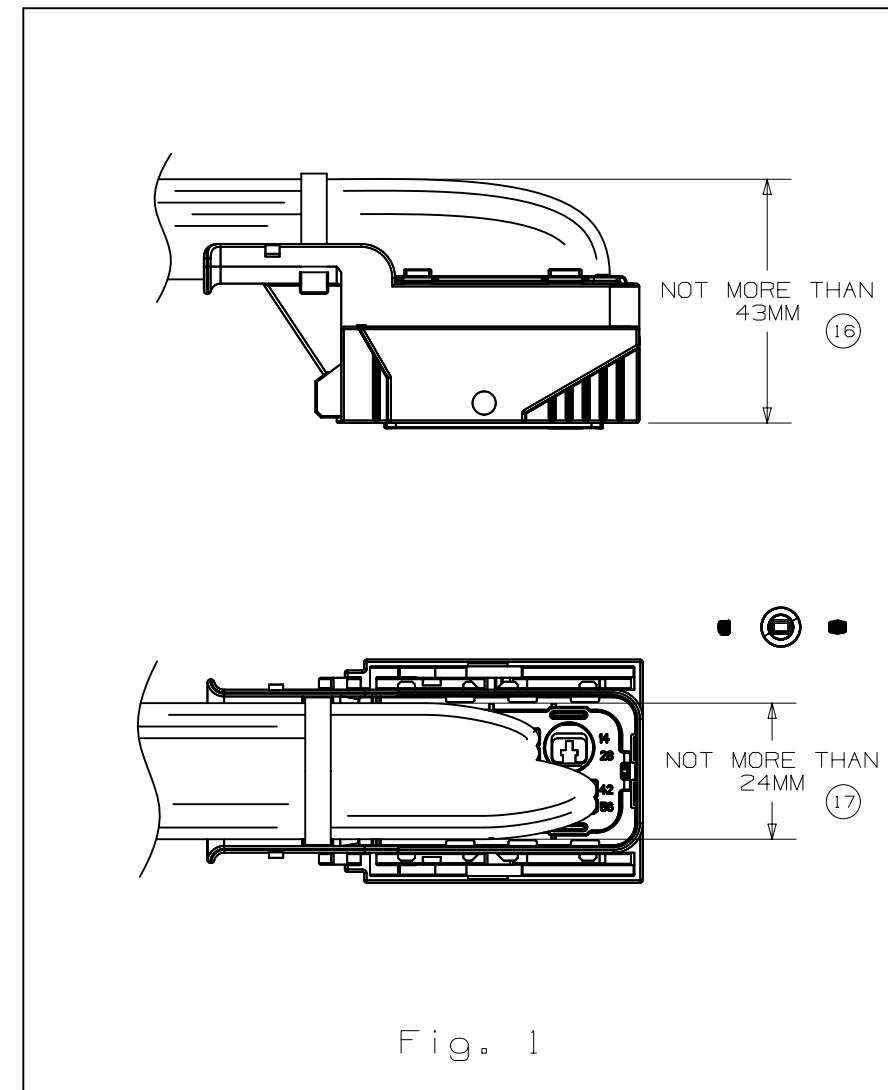
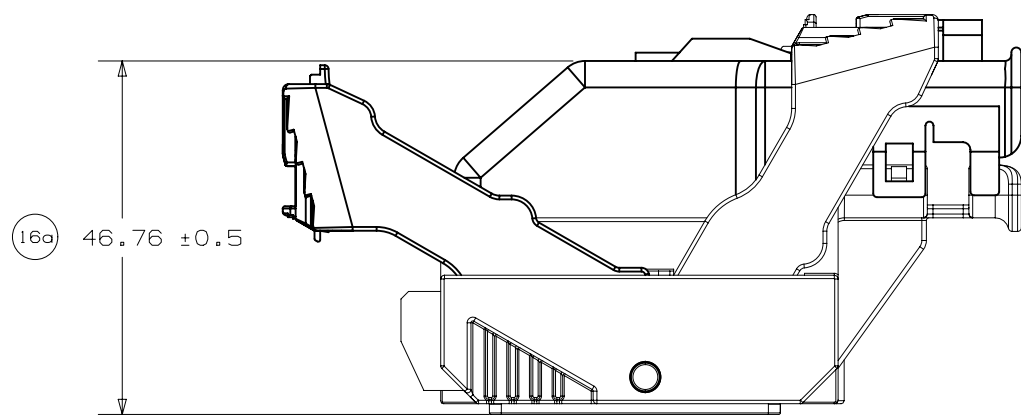

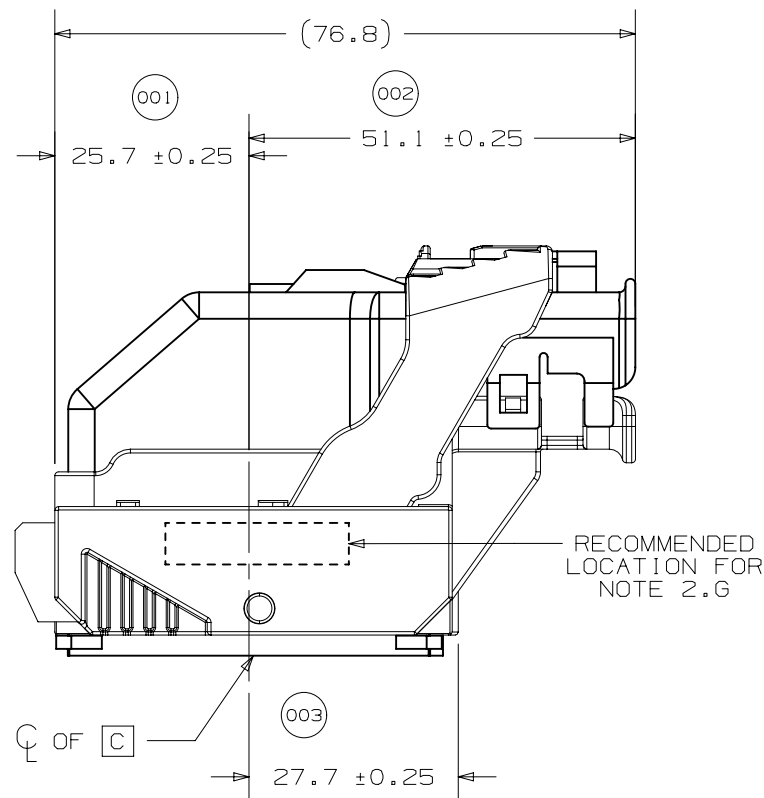

WIRE DRESS OPTION 0 SHOWN

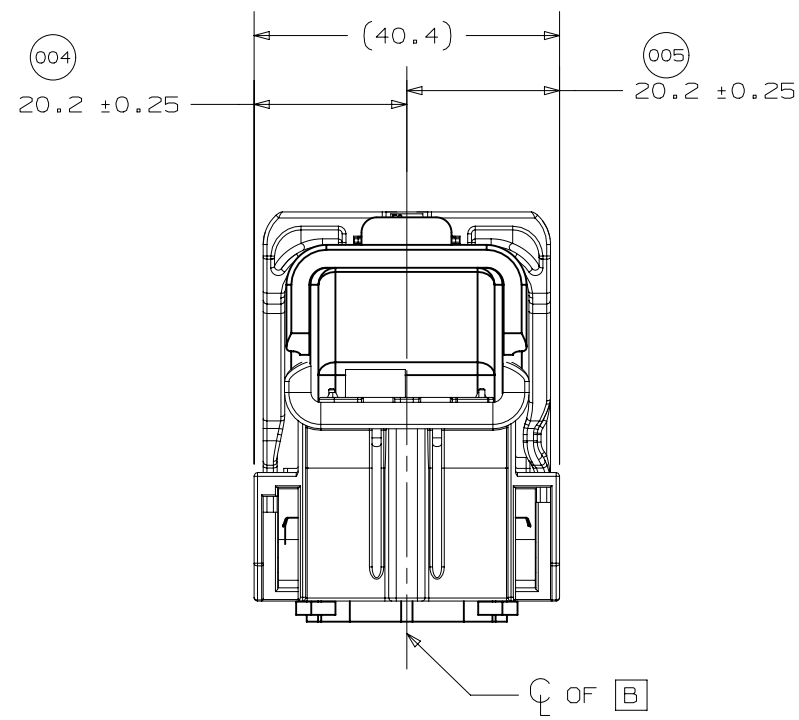

WIRE DRESS OPTION 0 SHOWN

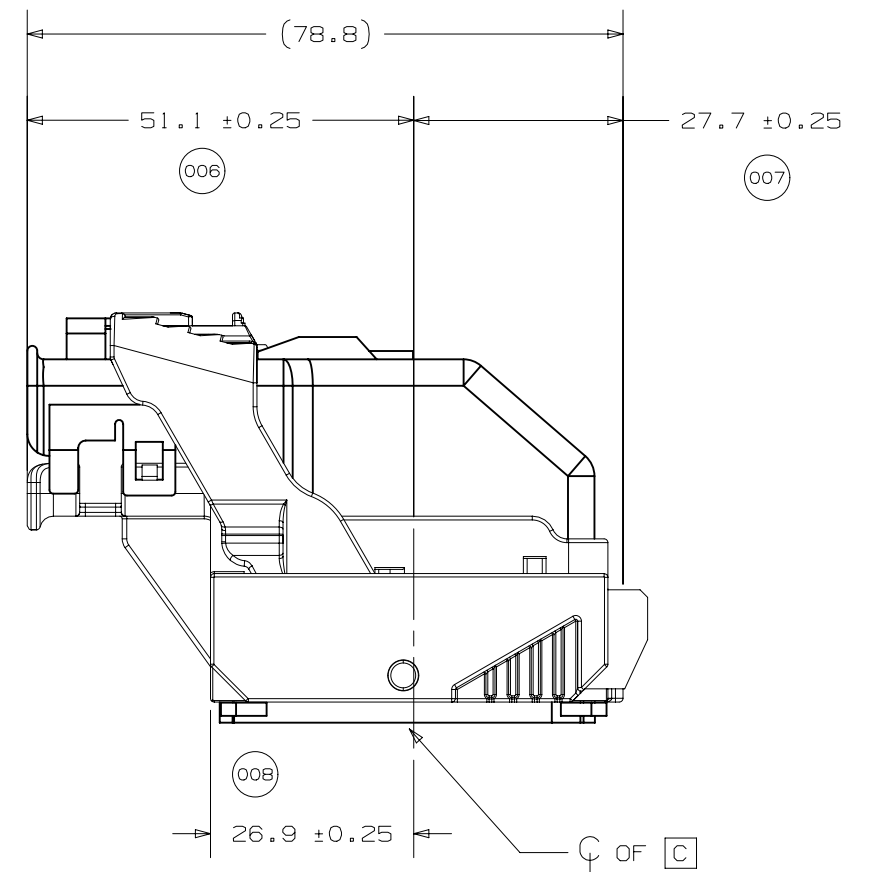

WIRE DRESS OPTION 9 SHOWN



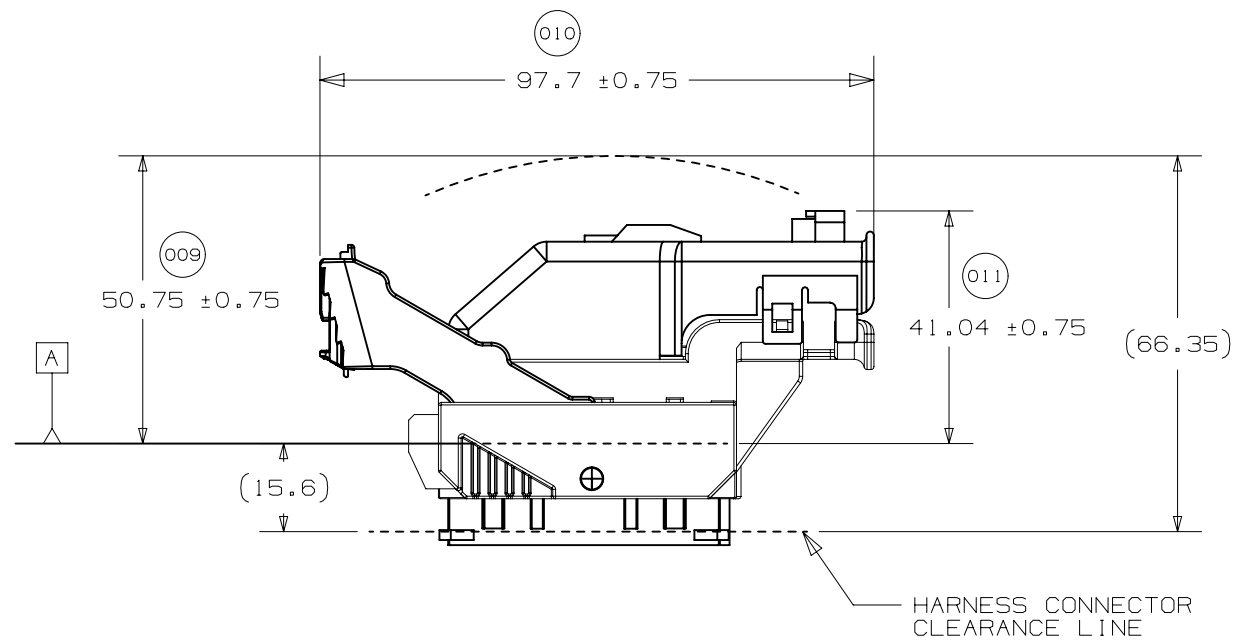
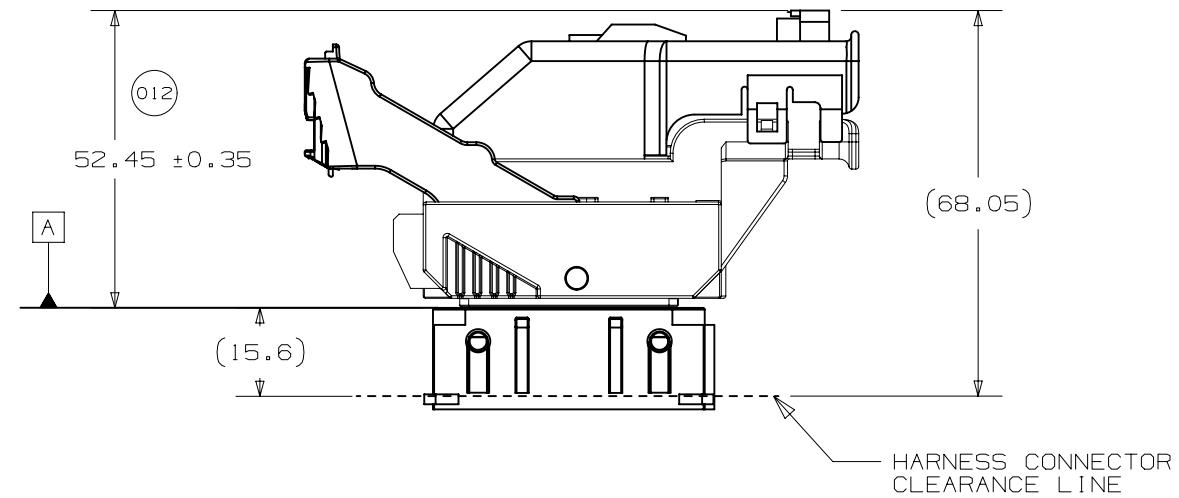

HARNESS CONNECTOR ASSEMBLY  
IN PRE-LOCK POSITION

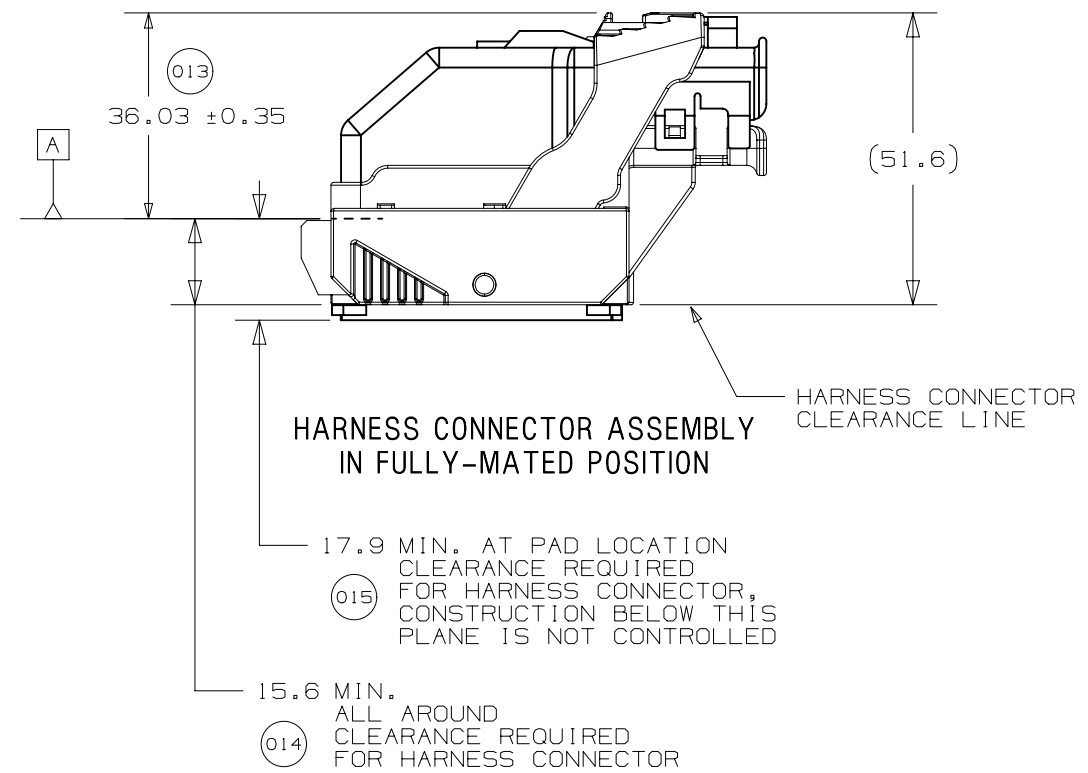

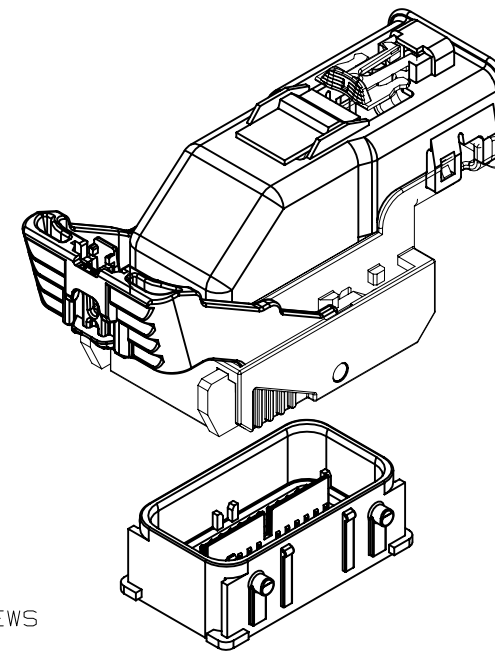
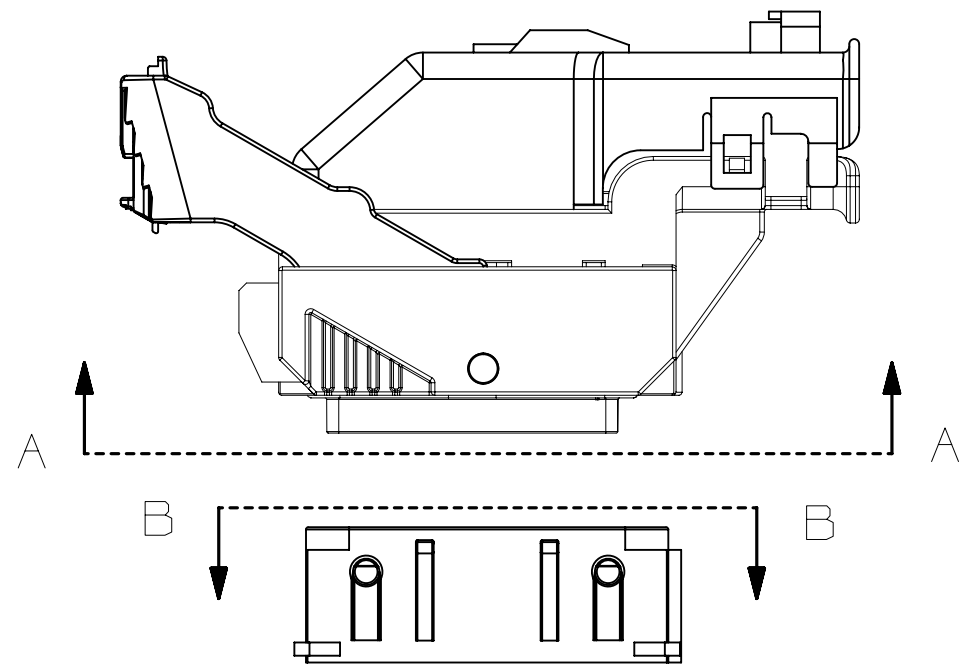

NOTE: REFERENCE THE COMPONENT TABLE FOR KEY OPTIONS AND CONFIGURATIONS

INTERFACE SIDE SHOWN IN ALL SECTION VIEWS

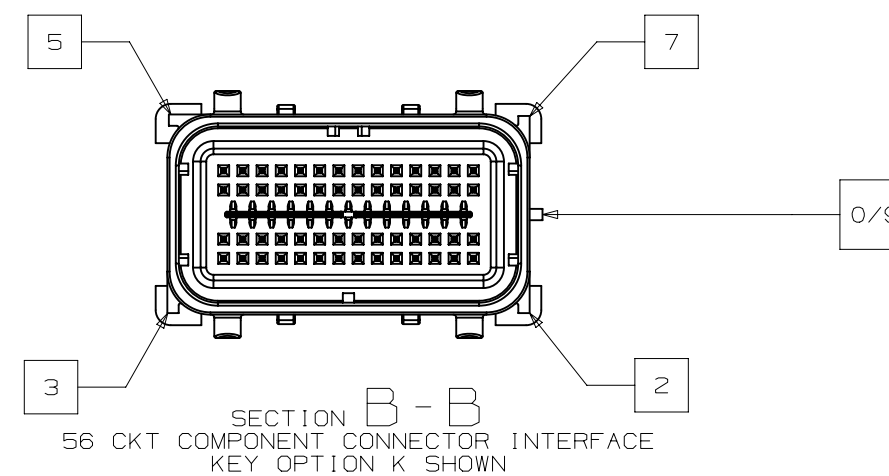
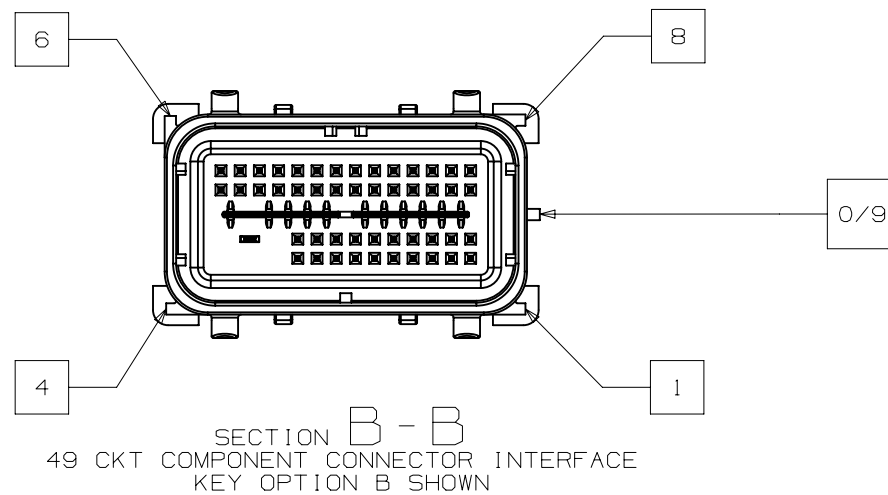
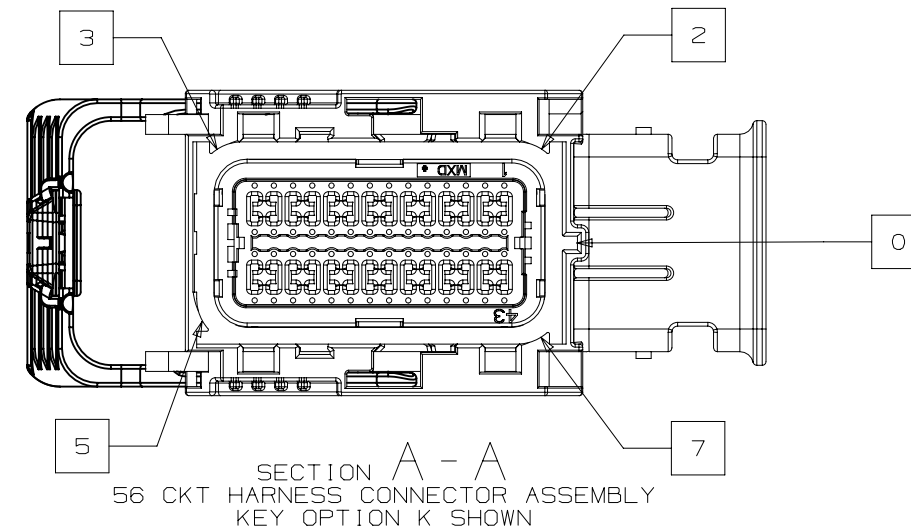
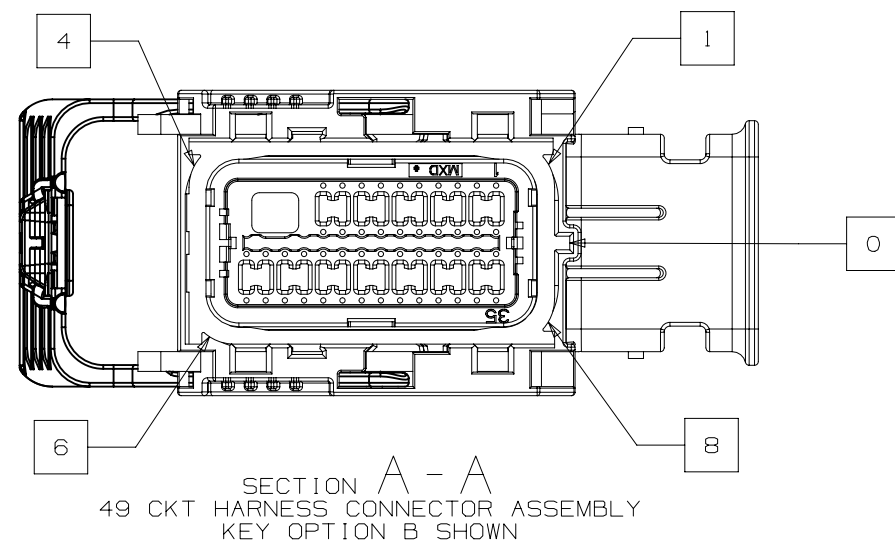

PAGE TITLE  
KEY ID REF - WIRE DRESS OPTION 0

DRAWING NUMBER  
12672832

DWG STATUS		
ST	REV	PD1
R	001	

PAGE NUMBER  
11 OF 23



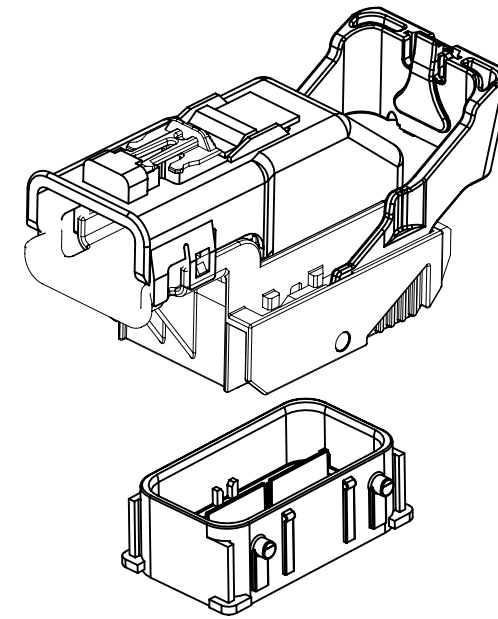
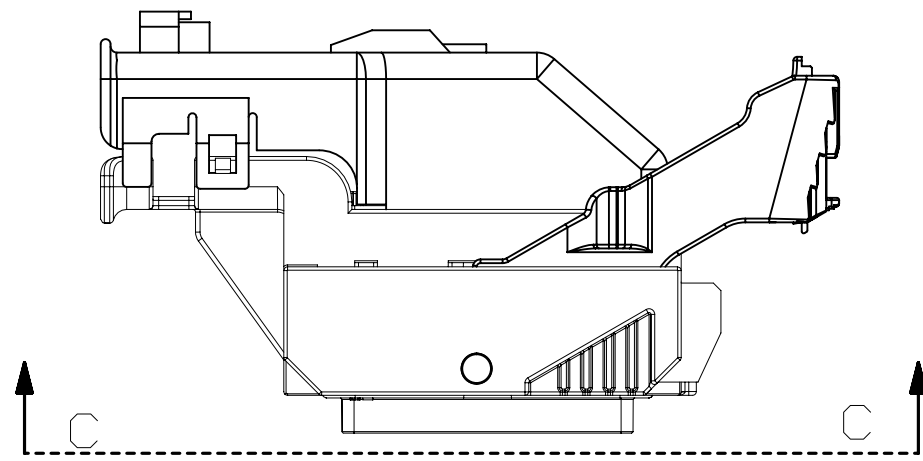

NOTE: REFERENCE THE COMPONENT TABLE FOR KEY OPTIONS AND CONFIGURATIONS

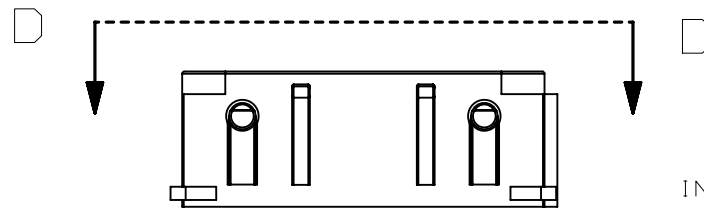

INTERFACE SIDE SHOWN ON ALL SECTION VIEWS

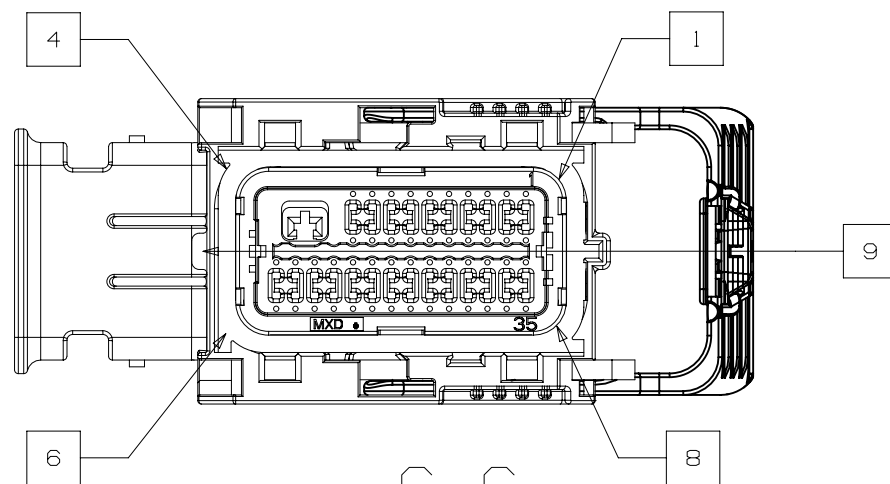

SECTION C - C  
49 CKT HARNESS CONNECTOR ASSEMBLY  
KEY OPTION B SHOWN

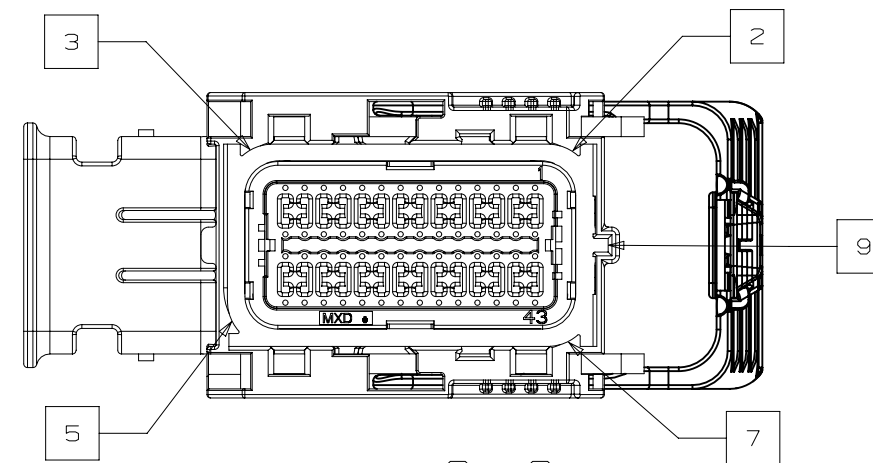

SECTION C - C  
56 CKT HARNESS CONNECTOR ASSEMBLY  
KEY OPTION K SHOWN

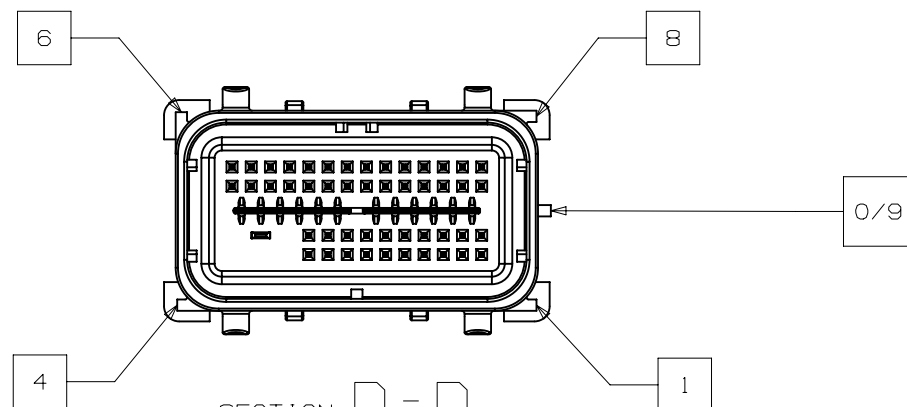

SECTION D - D  
49 CKT COMPONENT CONNECTOR INTERFACE  
KEY OPTION B SHOWN

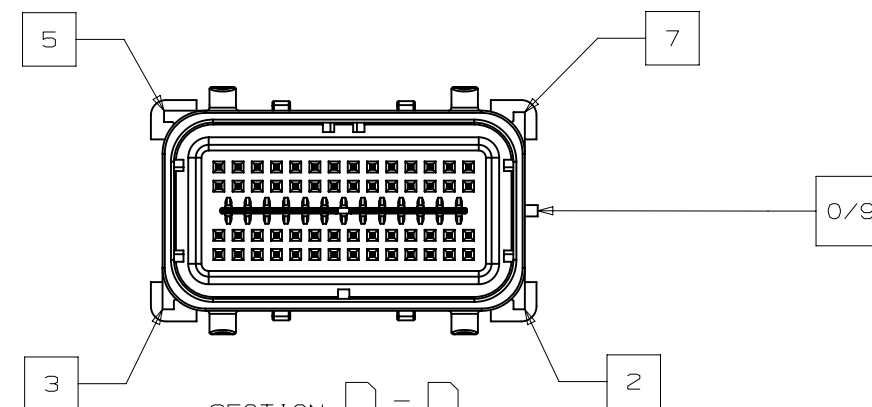

SECTION D - D  
56 CKT COMPONENT CONNECTOR INTERFACE  
KEY OPTION K SHOWN



PAGE TITLE  
KEY ID REF - WIRE DRESS OPTION 9

DRAWING NUMBER  
12672832

DWG STATUS			PAGE NUMBER
ST	REV	PD1	
R	001		12 OF 23

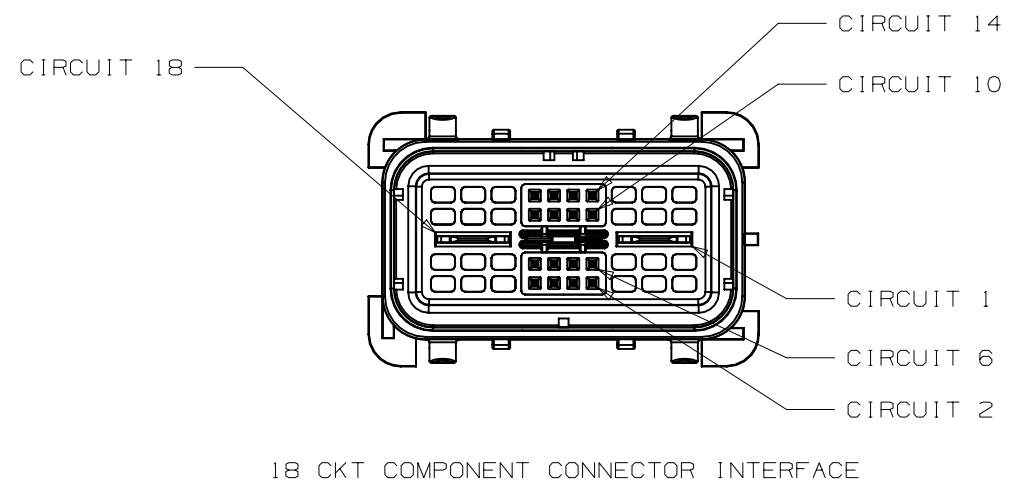
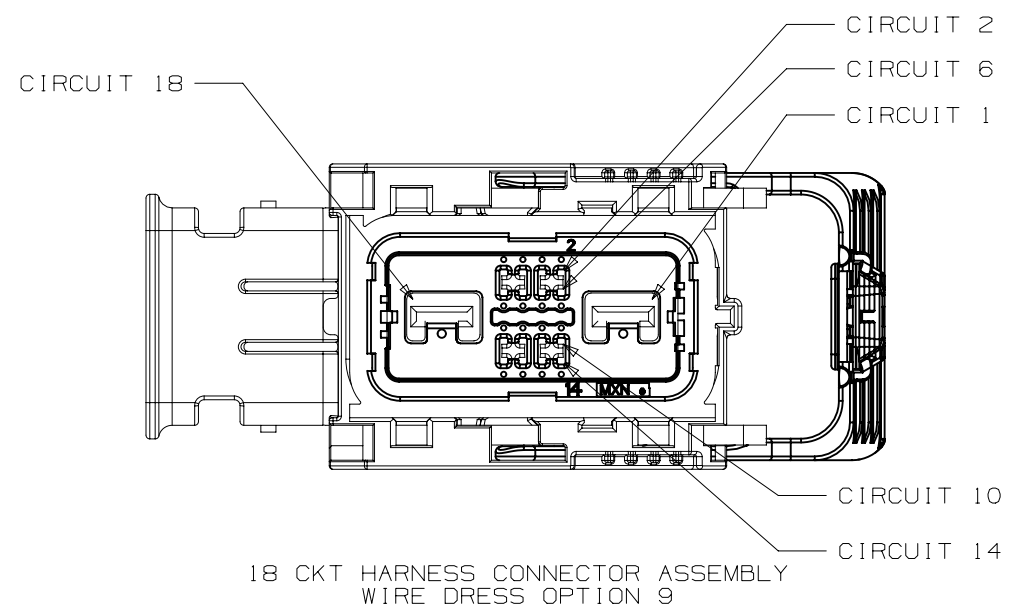
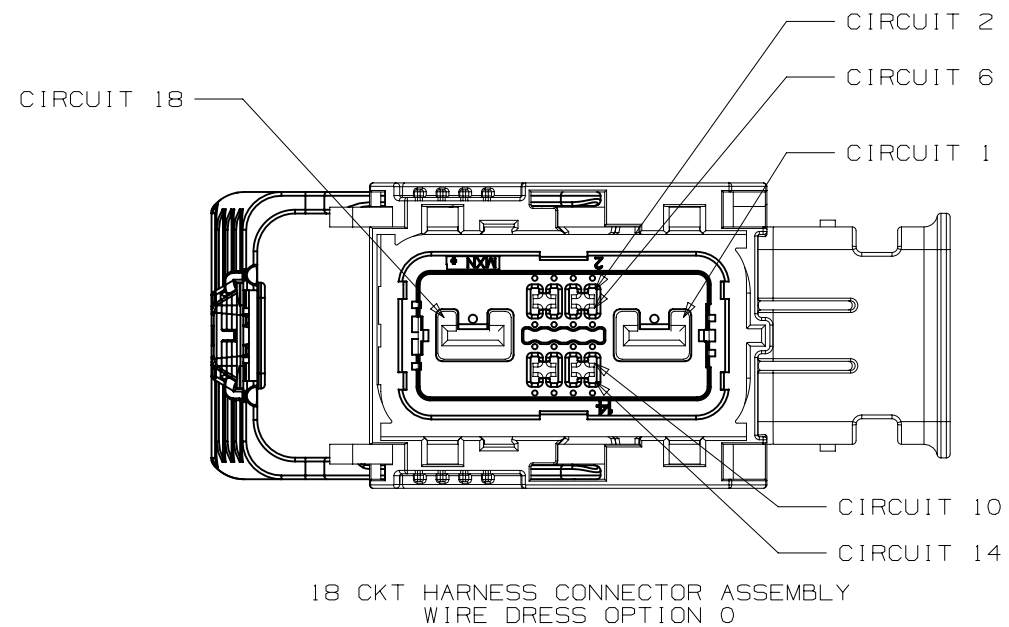

INTERFACE SIDE SHOWN ON ALL VIEWS



PAGE TITLE  
CIRCUIT CONFIGURATIONS

DRAWING NUMBER  
12672832

DWG STATUS			PAGE NUMBER	
ST	REV	PDI	13	OF 23
R	001			

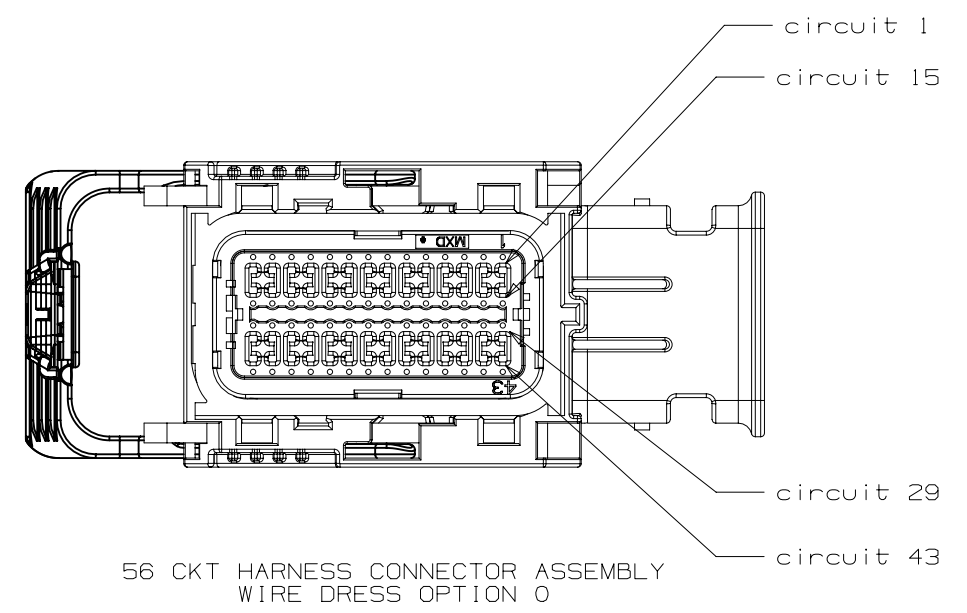
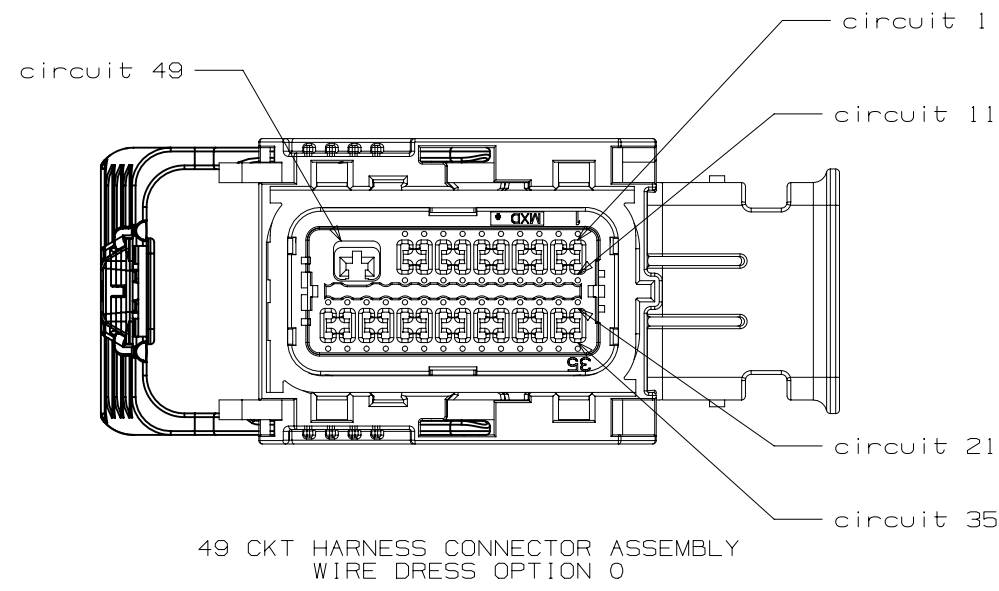

INTERFACE SIDE SHOWN ON ALL VIEWS

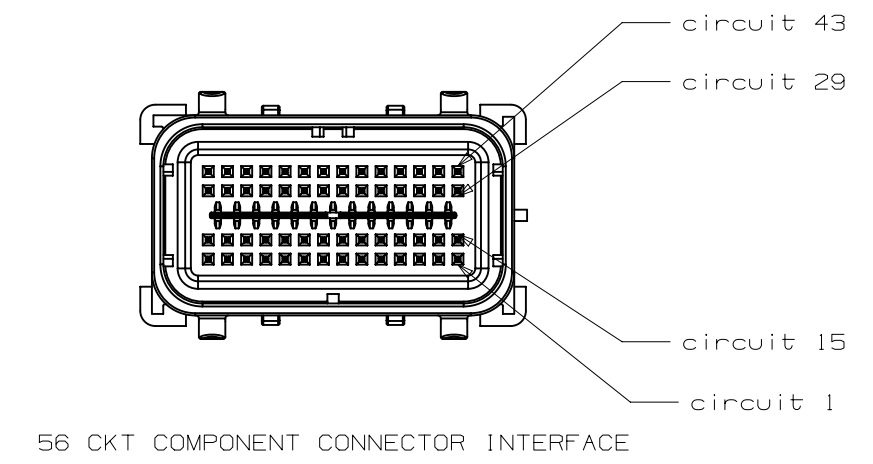
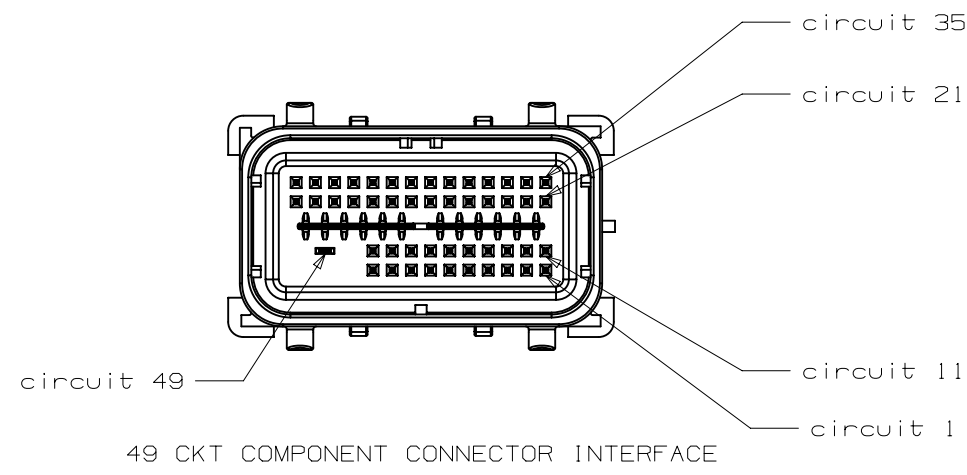
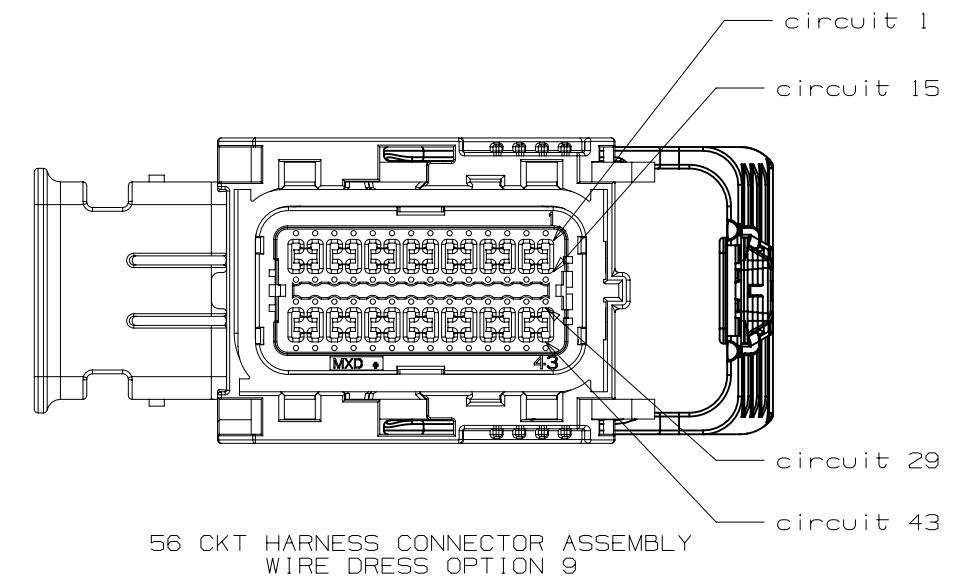
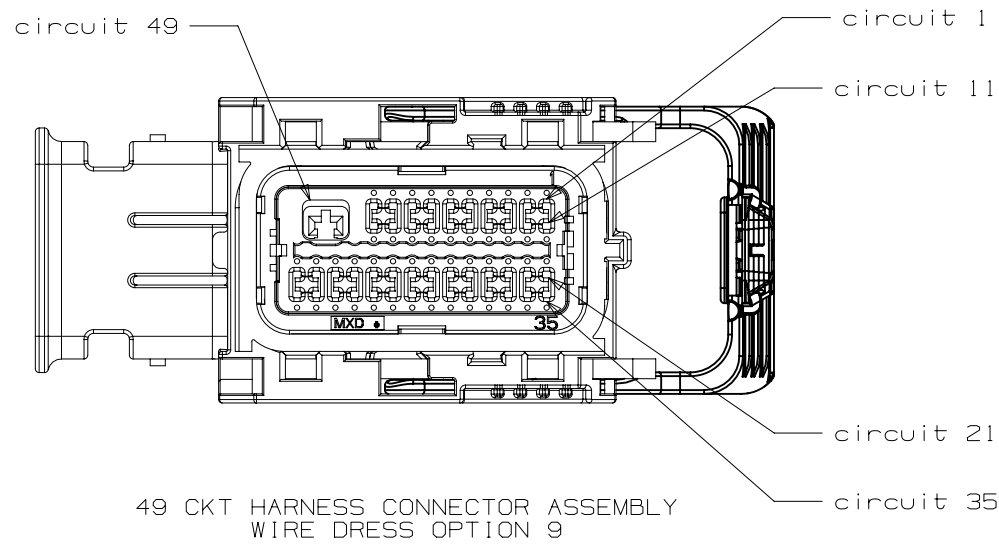

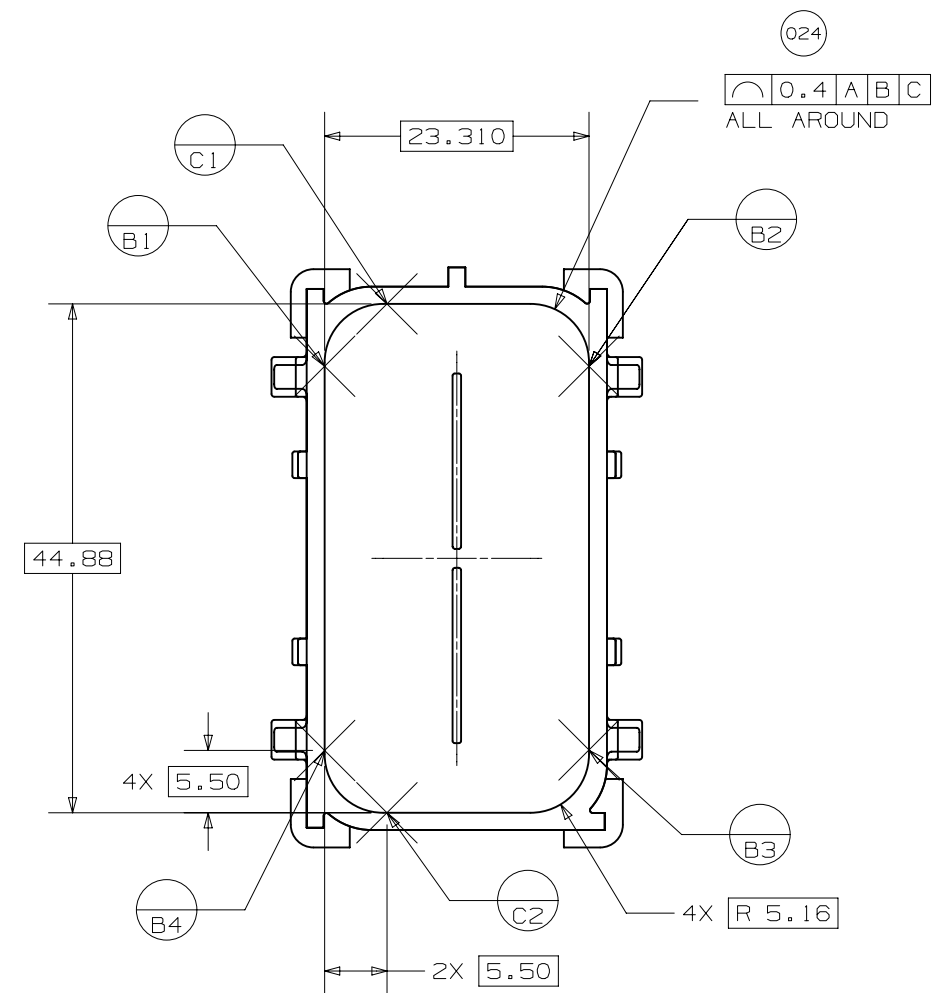
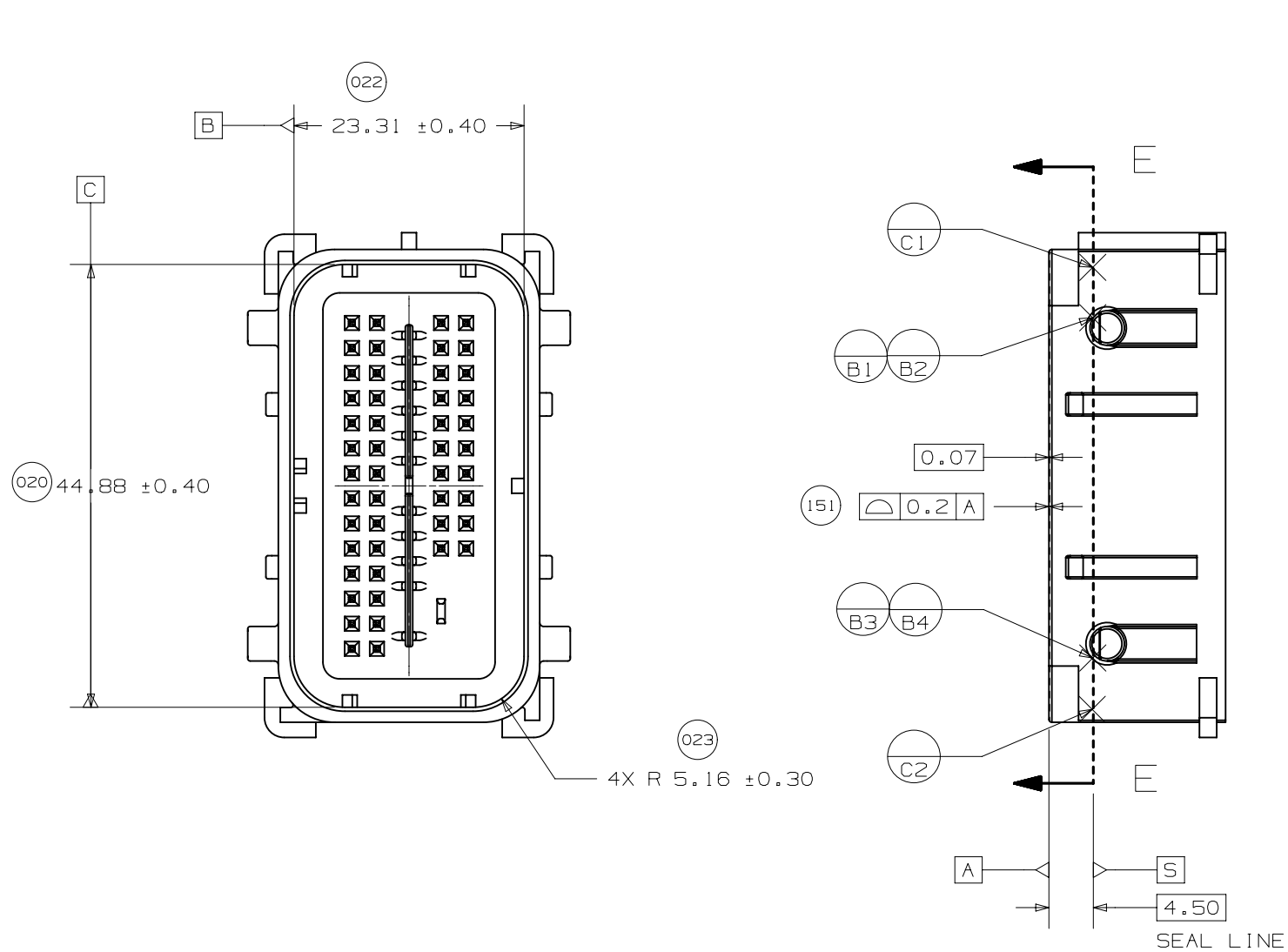
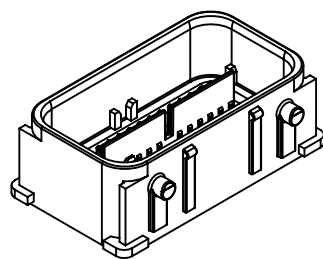

UNLESS SPECIFIED, TOLERANCE OF THE DEVICE INTERFACE TO BE  $\triangle 0.13 A B C$



PAGE TITLE  
COMPONENT CONNECTOR INTERFACE

DRAWING NUMBER  
12672832

DWG STATUS			PAGE NUMBER
ST	REV	PD1	
R	001		15 of 23

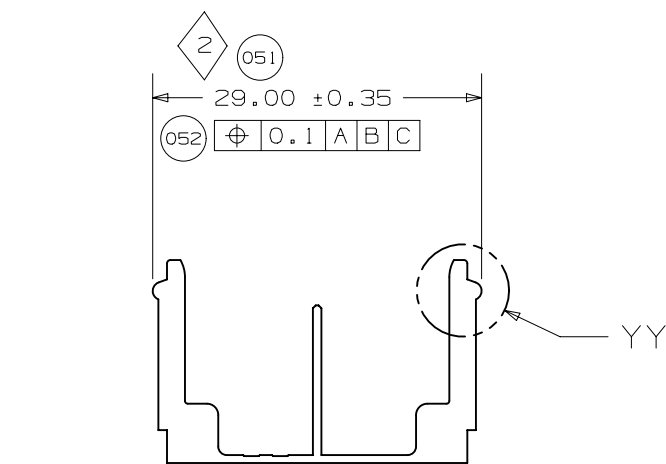
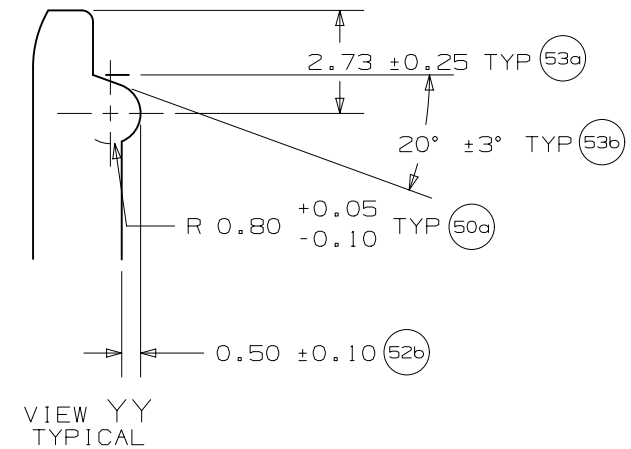
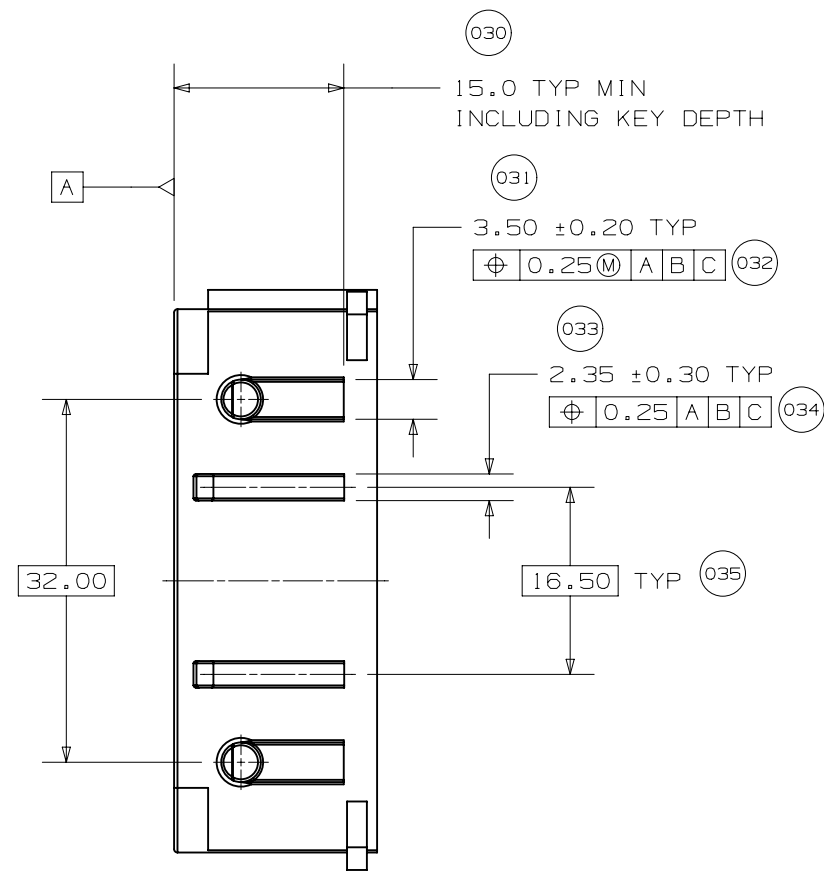
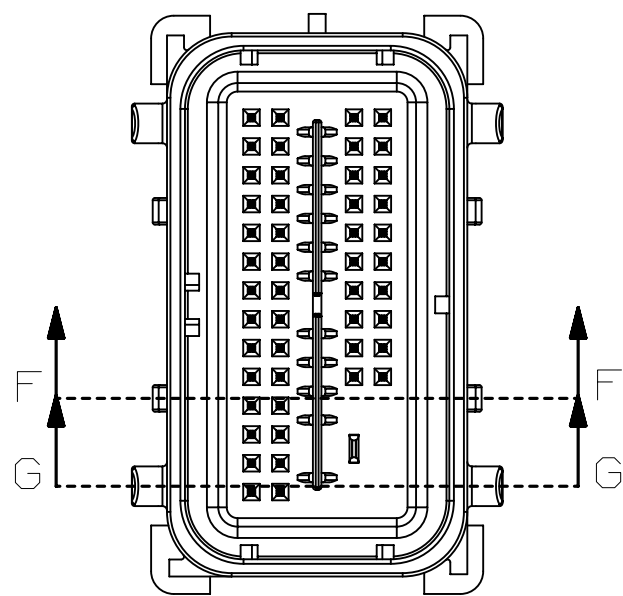

SECTION F - F  
(RELEASE FEATURE)

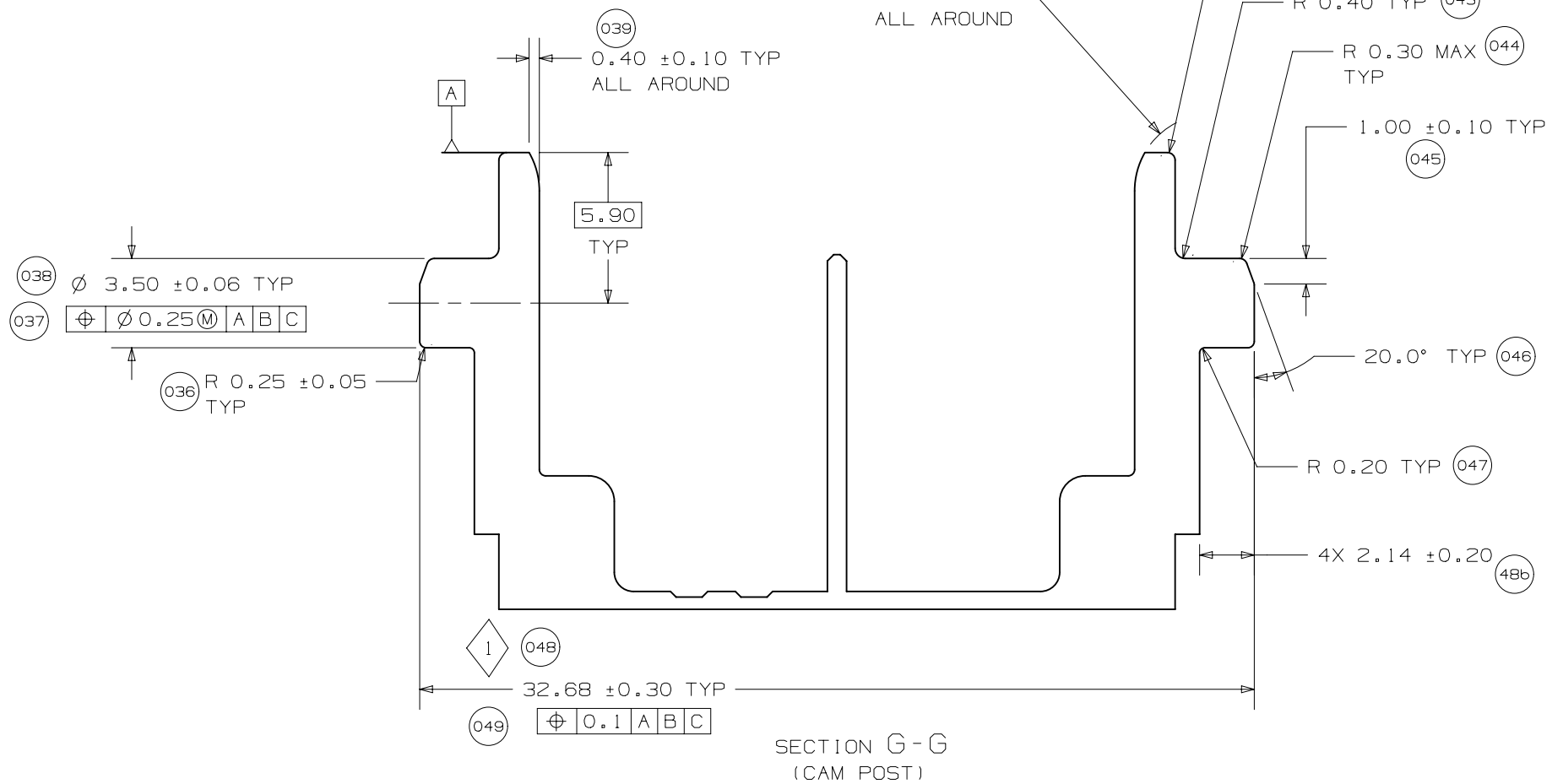

SECTION G - G  
(CAM POST)



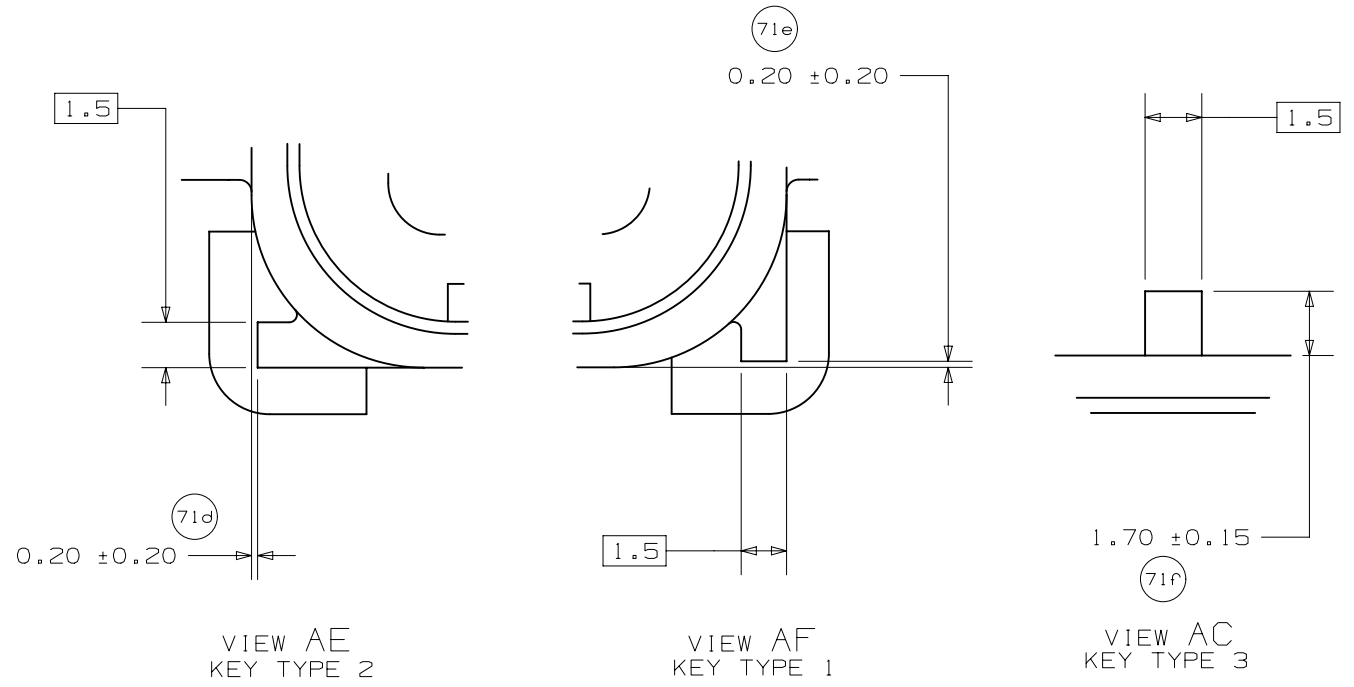
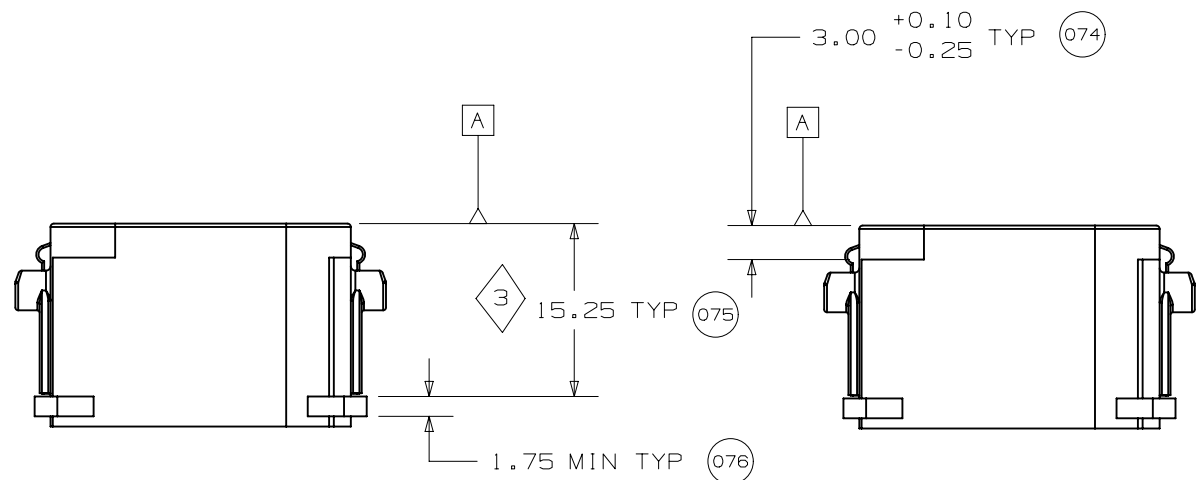
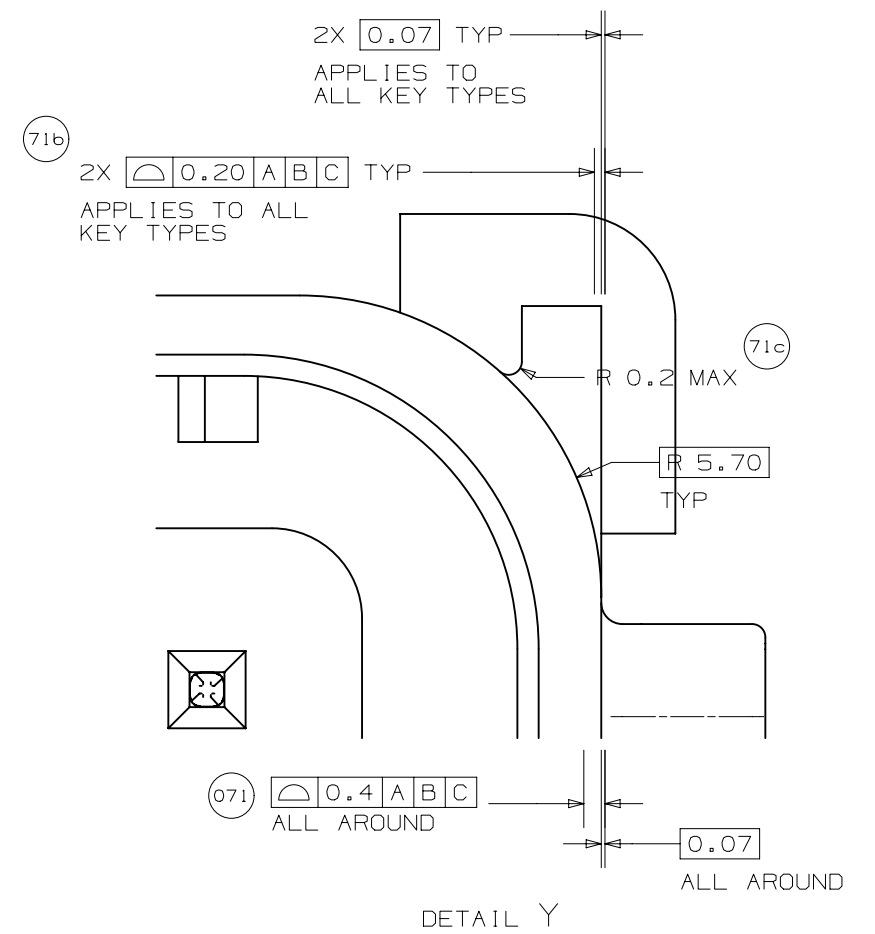
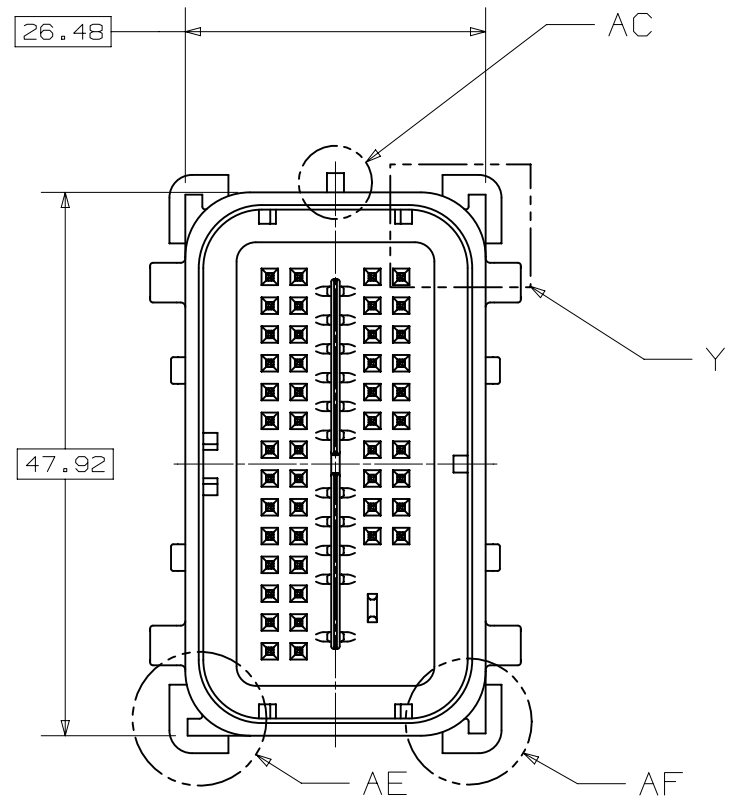
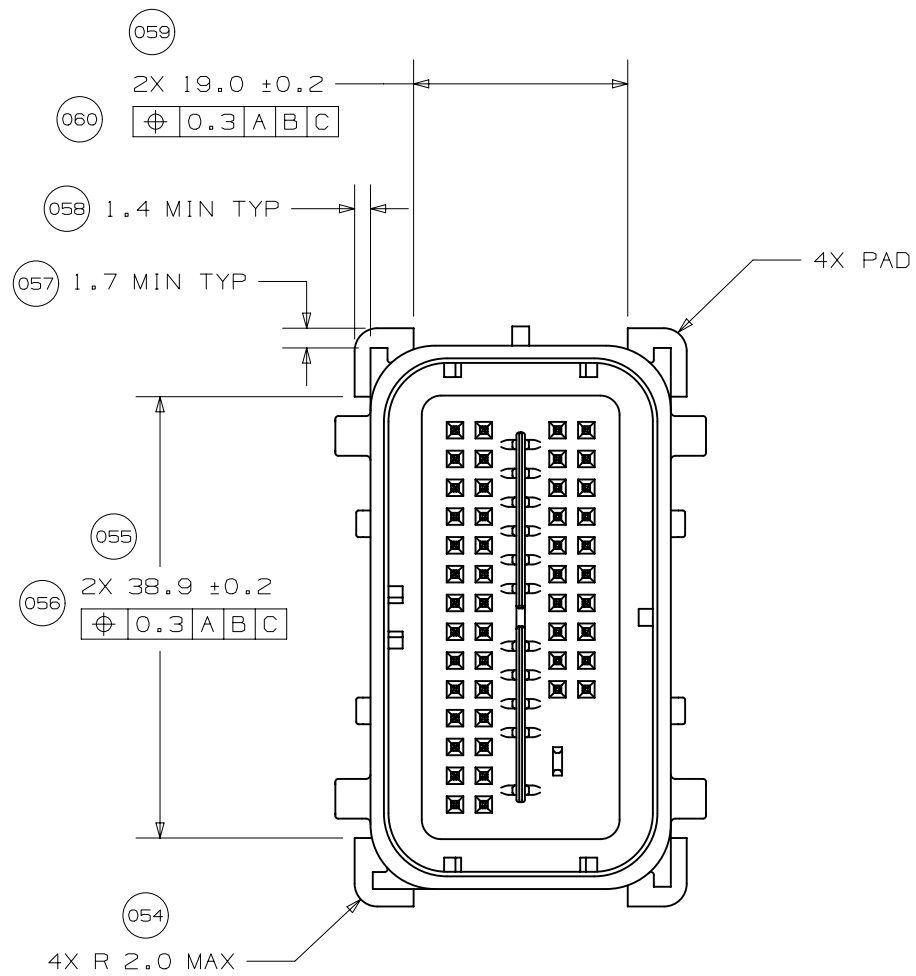

PAGE TITLE  
 COMPONENT CONNECTOR INTERFACE

DRAWING NUMBER  
 12672832

DWG STATUS			PAGE NUMBER
ST	REV	PD1	
R	001		17 of 23

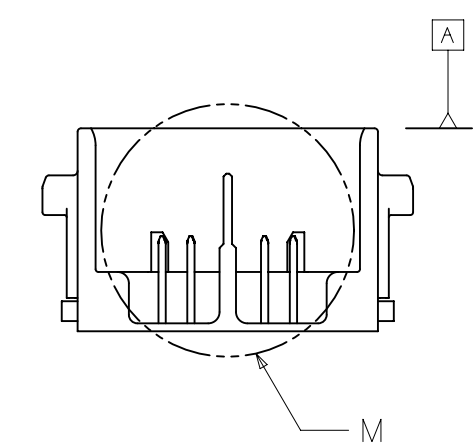
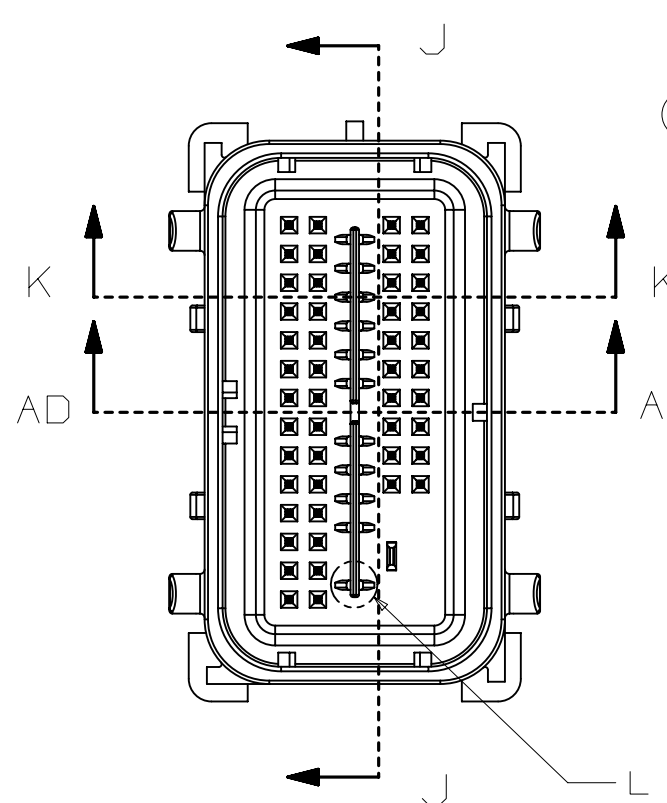

SECTION K-K

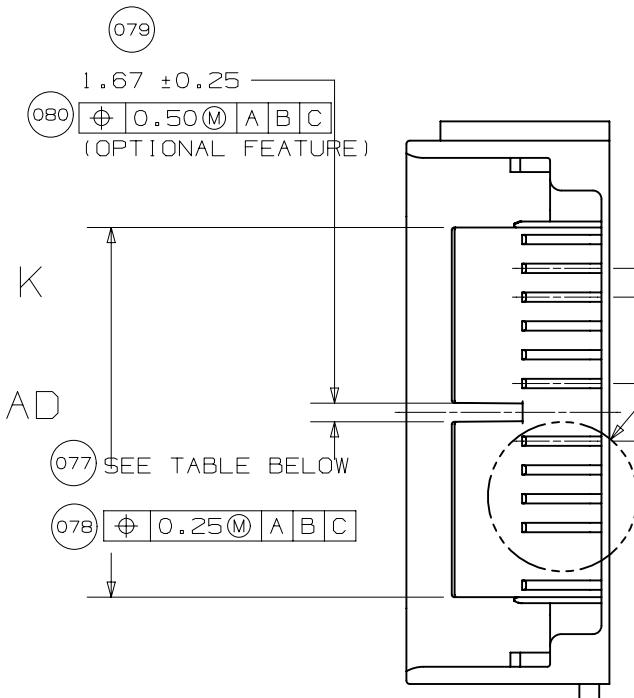

SECTION J-J

079 1.67 ±0.25  
 080  $\Phi$  0.50 (M) A B C (OPTIONAL FEATURE)  
 077 SEE TABLE BELOW  
 078  $\Phi$  0.25 (M) A B C

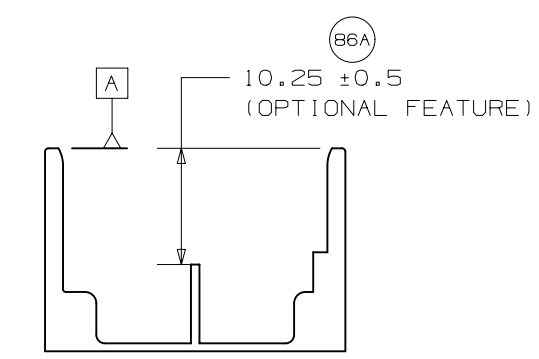

SECTION AD-AD

086A 10.25 ±0.5 (OPTIONAL FEATURE)

CKT	DIM 077
49 / 56 CKT	32.60 +0.10/-0.60
18 CKT	10.04 +0.10/-0.60

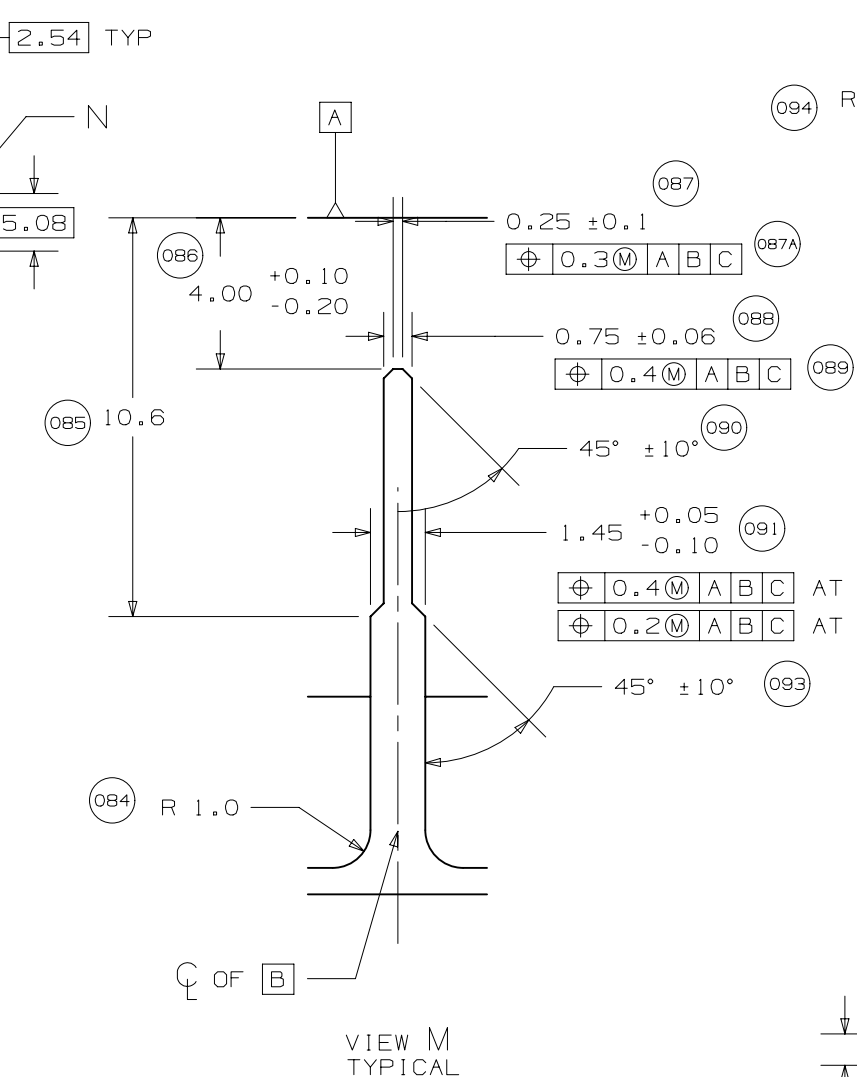

VIEW M TYPICAL

085 10.6  
 086 4.00 +0.10/-0.20  
 087 0.25 ±0.1  
 $\Phi$  0.3 (M) A B C 087A  
 0.75 ±0.06 088  
 $\Phi$  0.4 (M) A B C 089  
 45° ±10° 090  
 1.45 +0.05/-0.10 091  
 $\Phi$  0.4 (M) A B C AT TOP 092  
 $\Phi$  0.2 (M) A B C AT BOTTOM 092A  
 45° ±10° 093  
 084 R 1.0  
 CL OF B

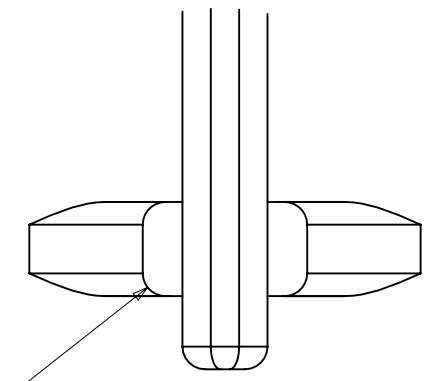

VIEW L

094 R 0.20 TYP

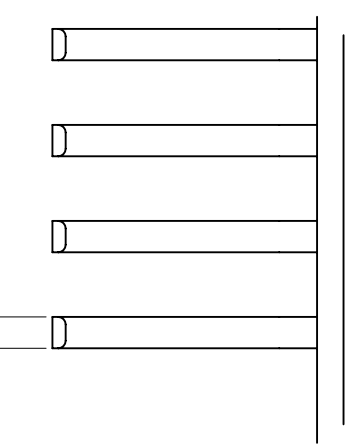

VIEW N

095 0.83 ±0.15 TYP  
 096  $\Phi$  0.5 (M) A B C



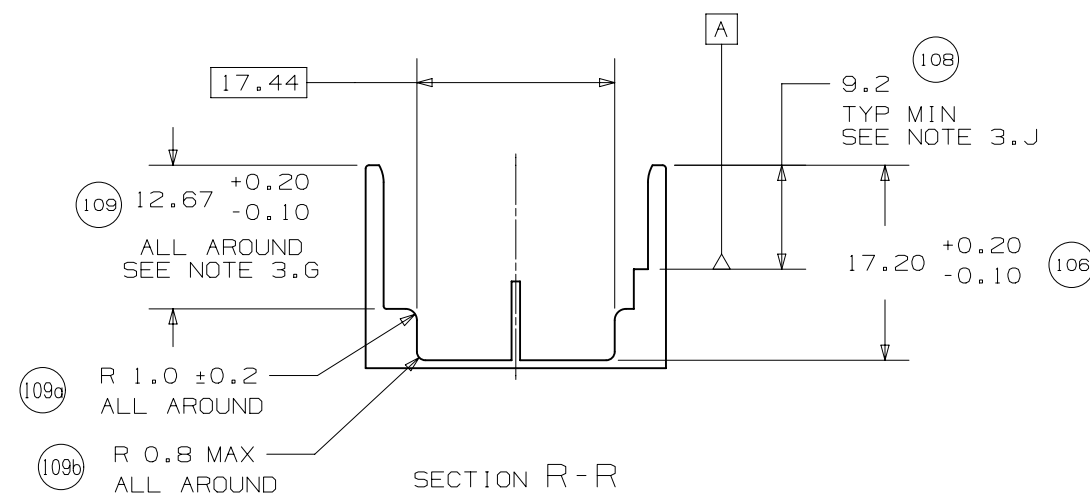
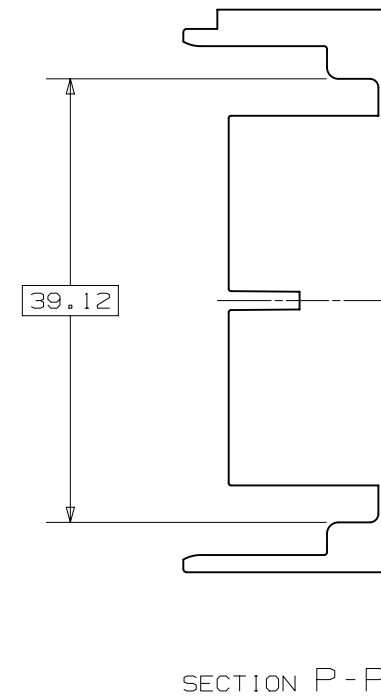
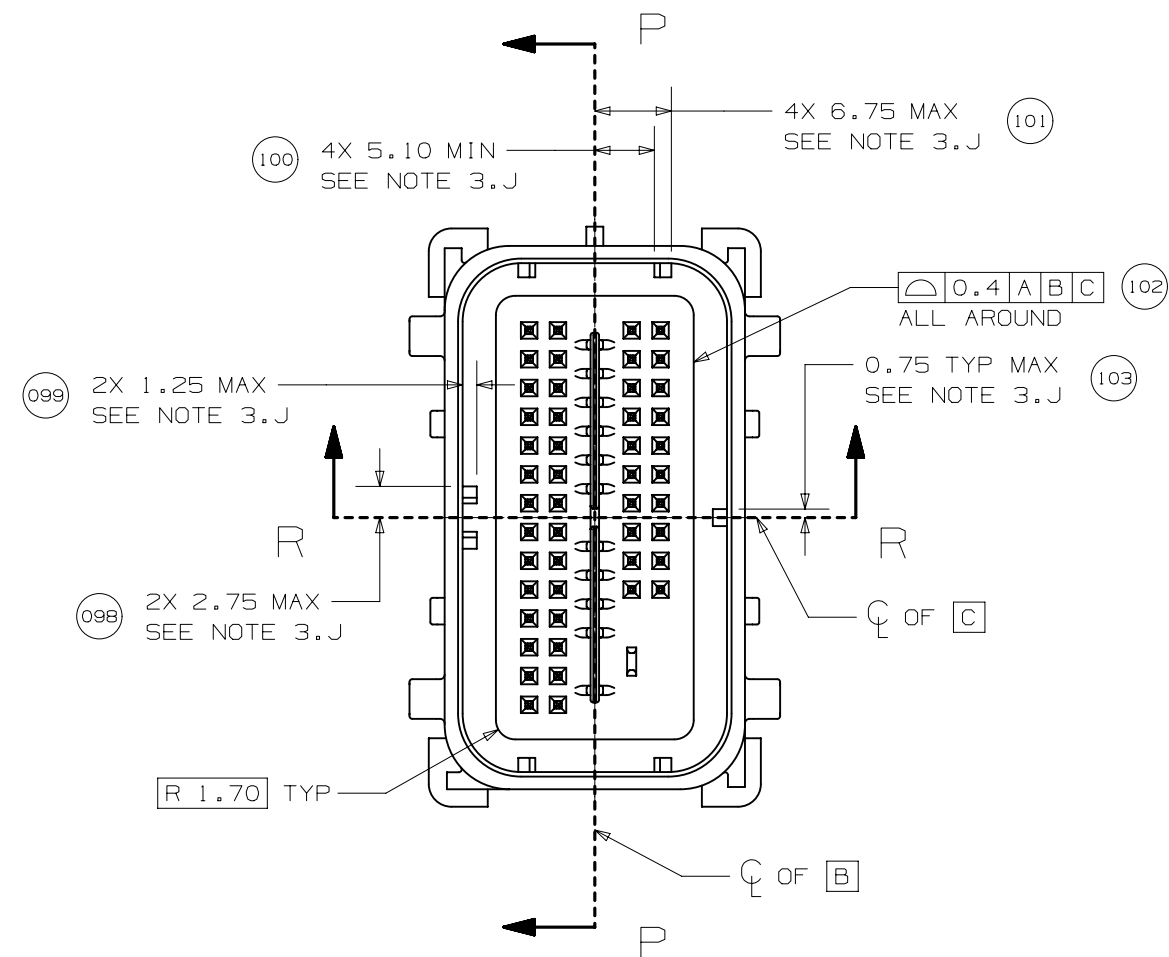



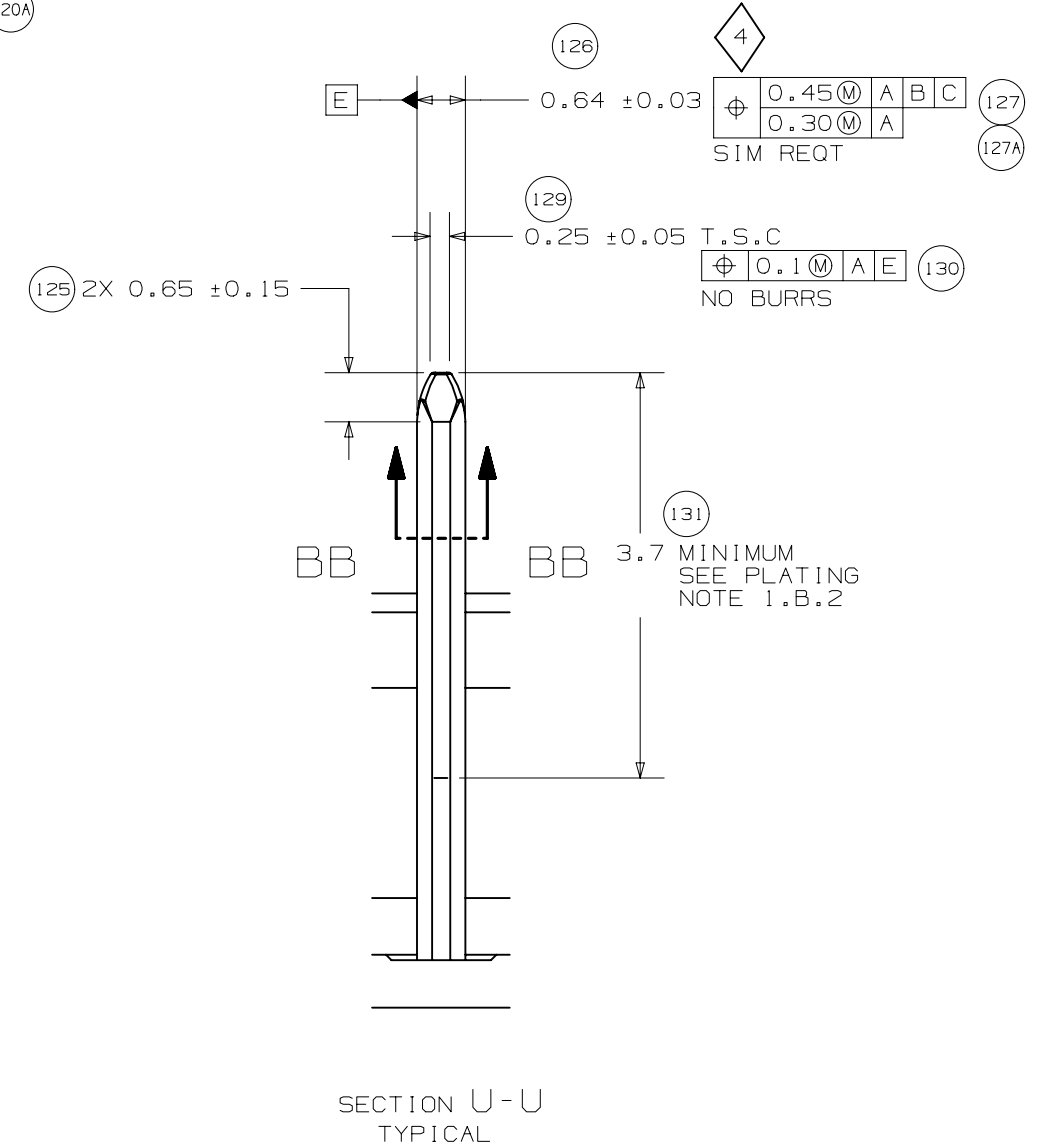
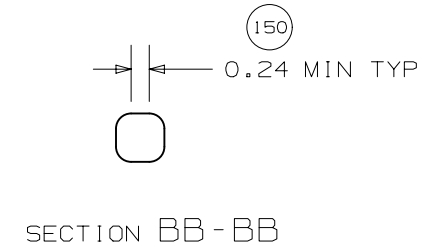
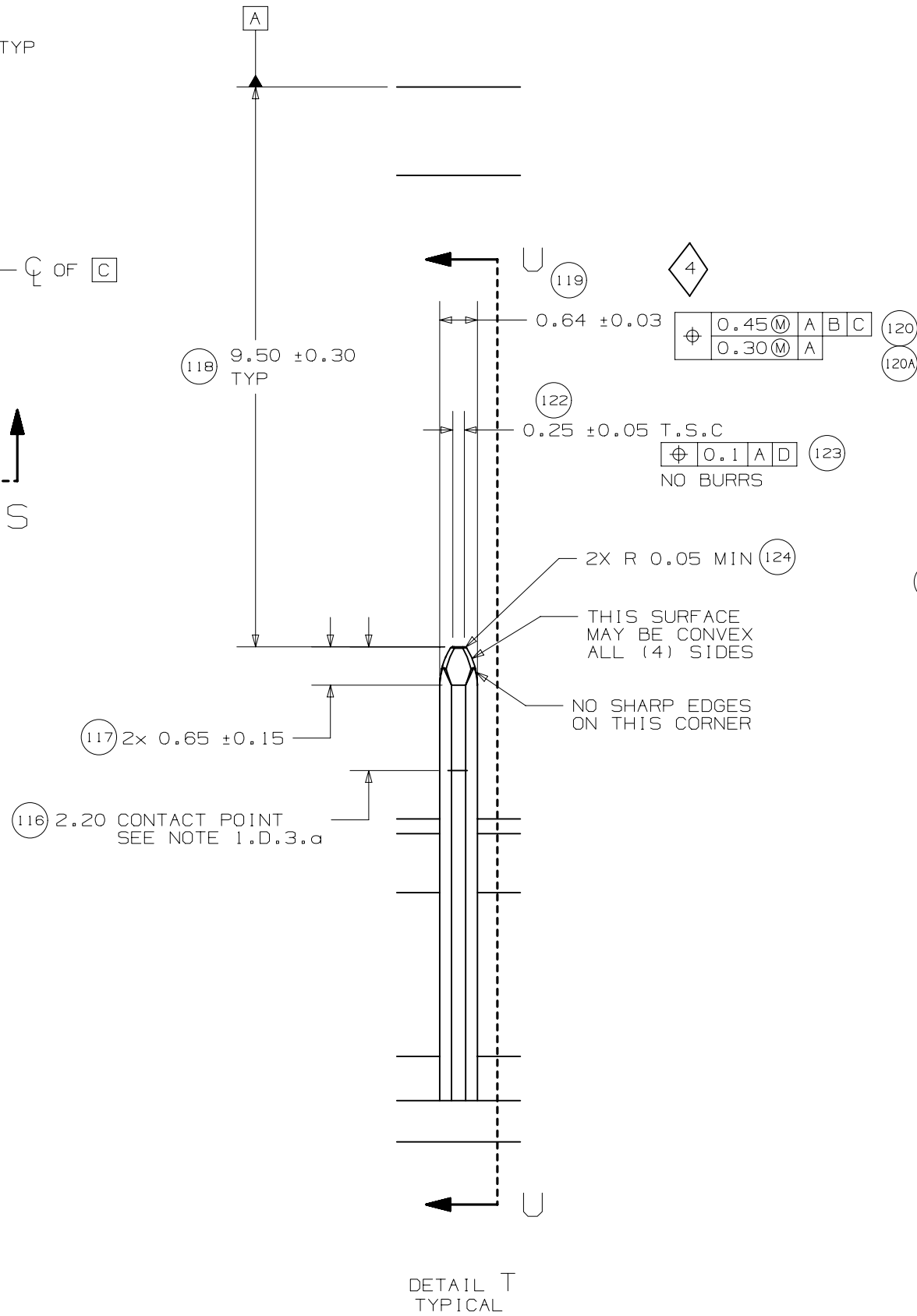
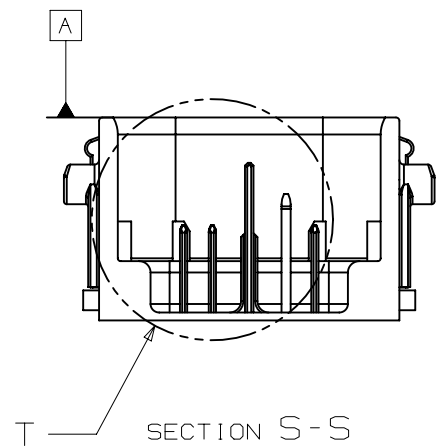
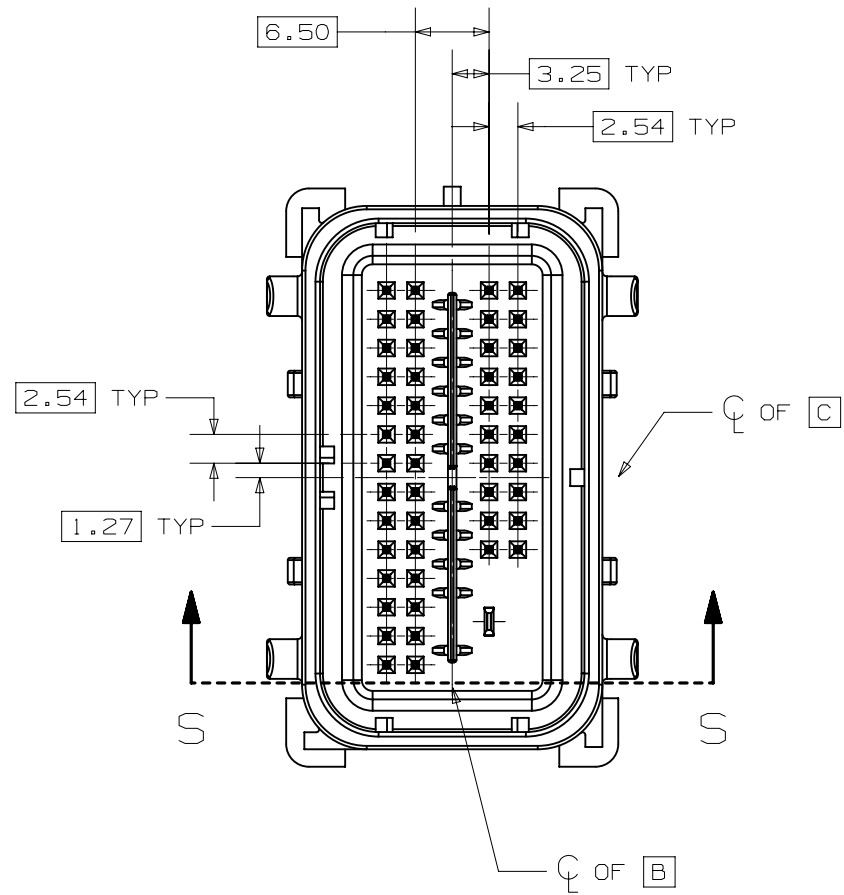

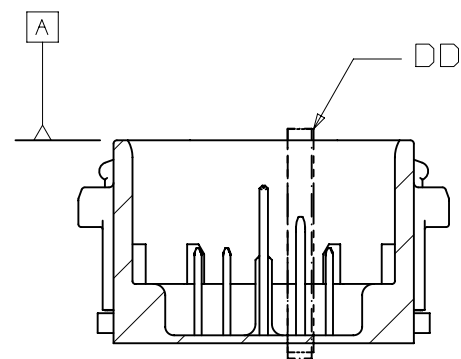
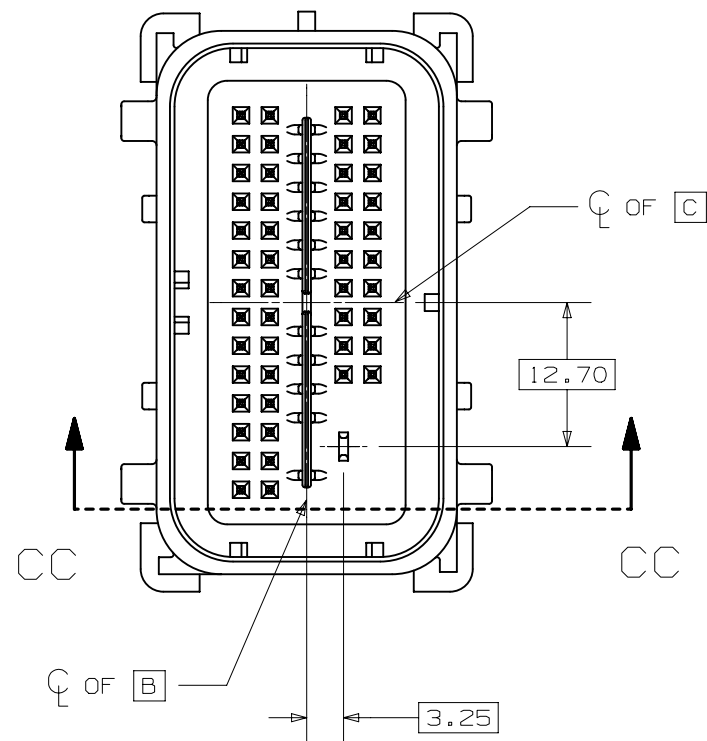

SECTION CC-CC

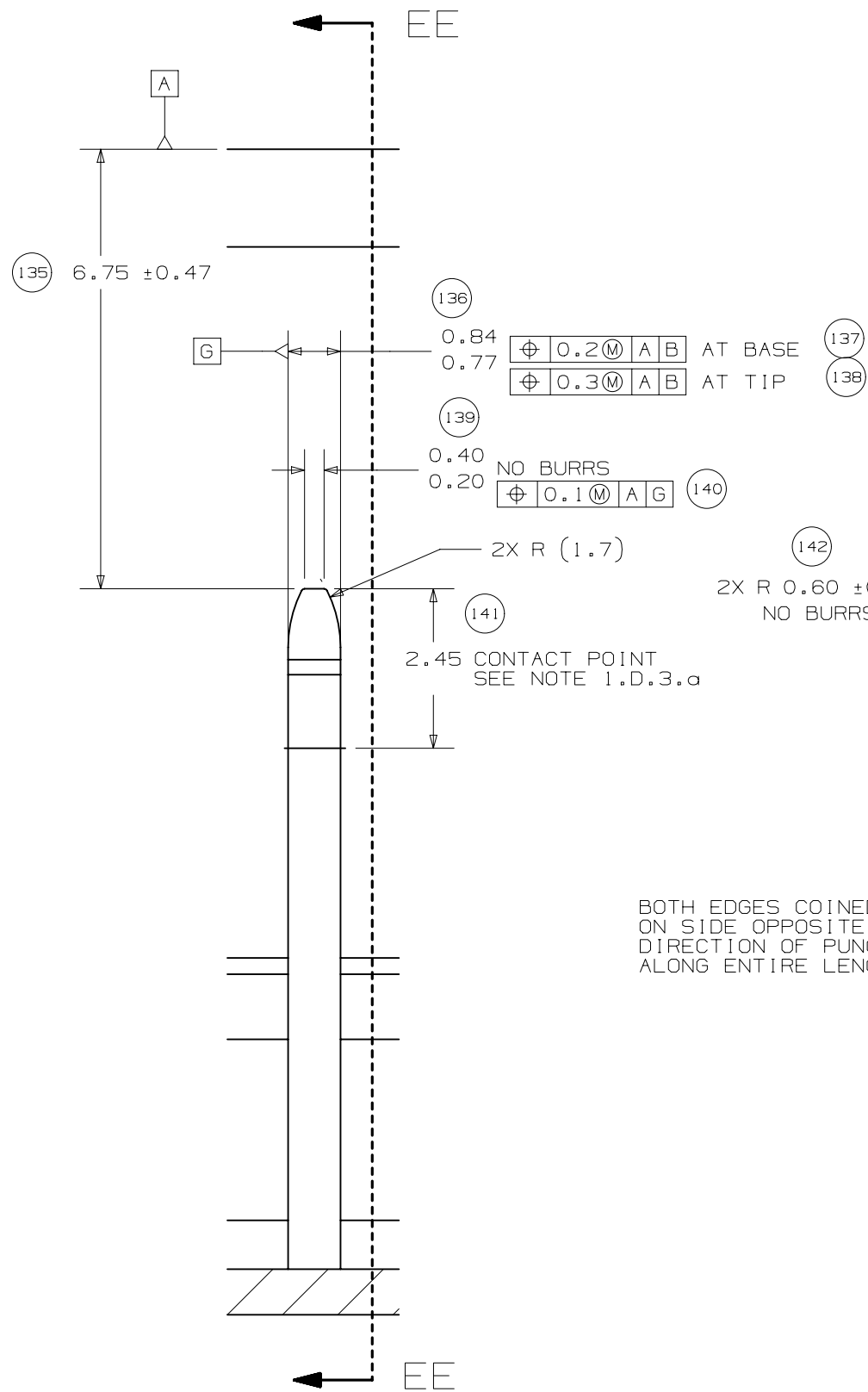

DETAIL DD  
TYPICAL

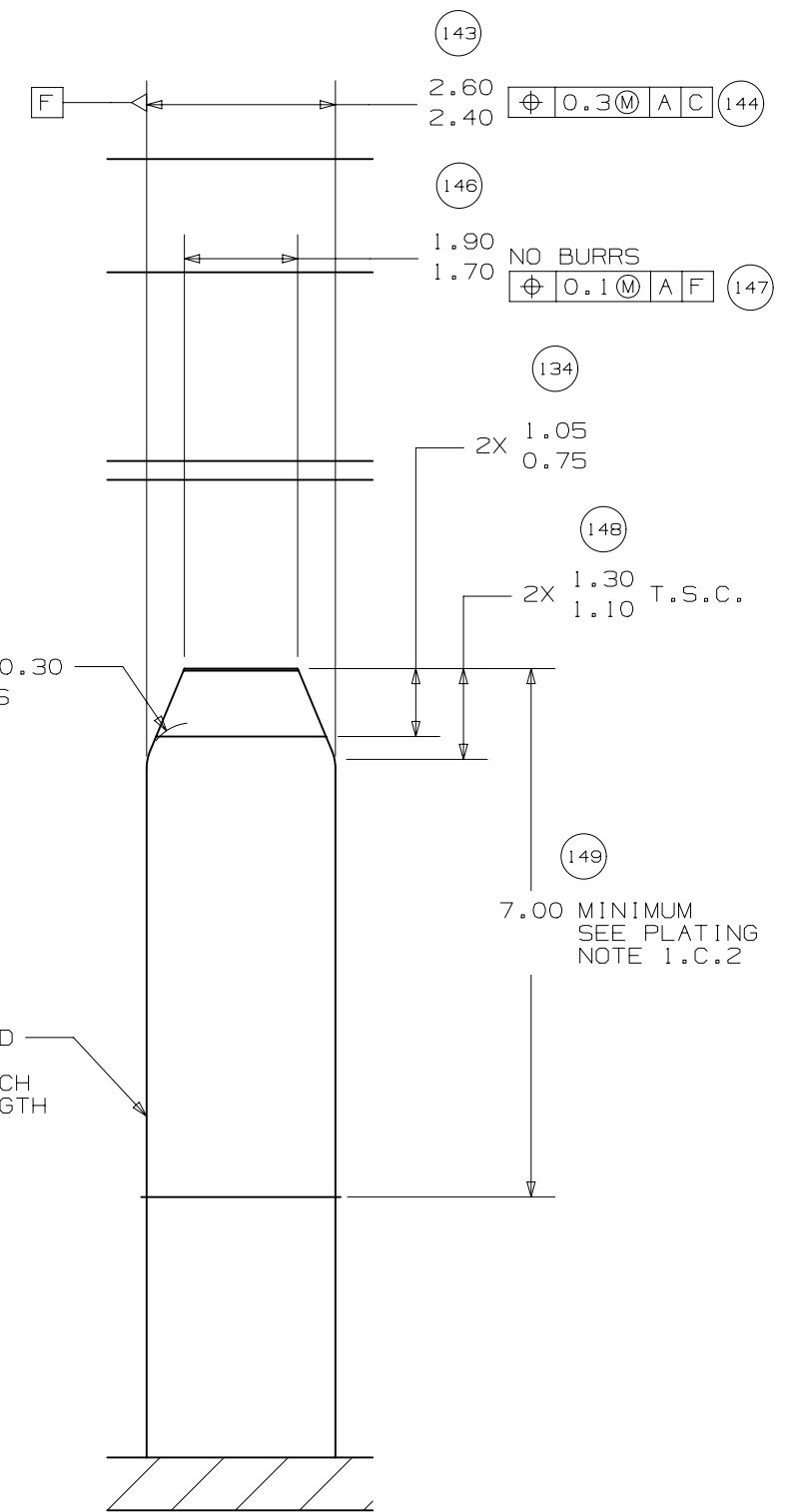

SECTION EE-EE  
TYPICAL



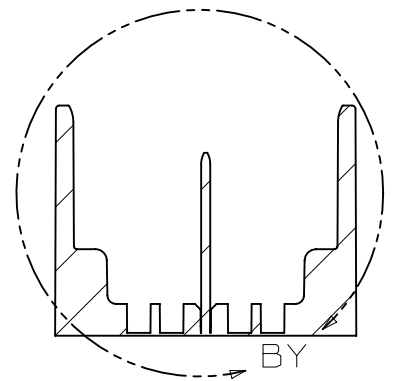
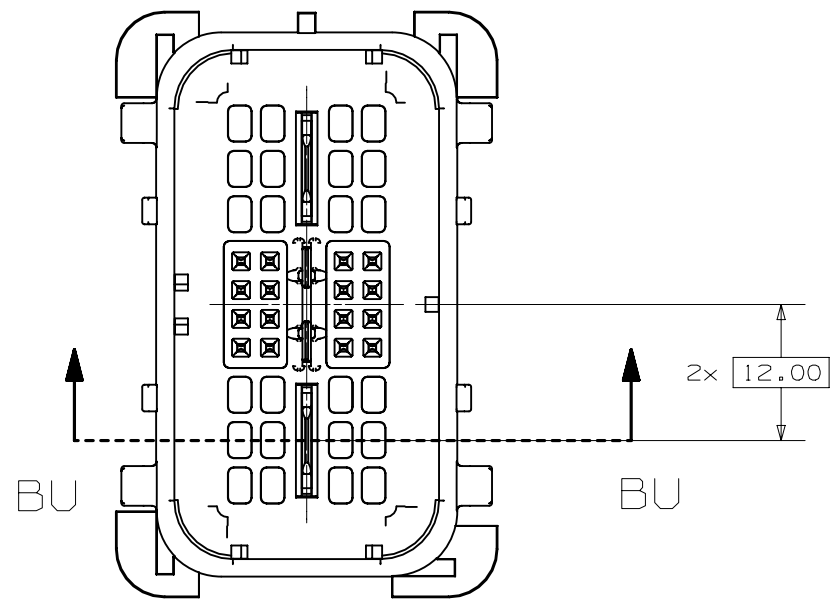

SECTION BU-BU

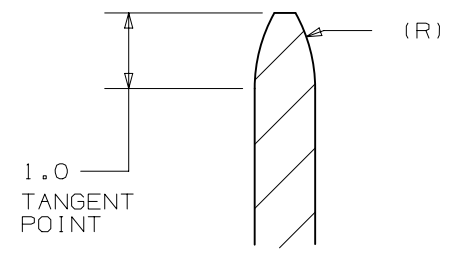

VIEW CA  
SCALE 10:1

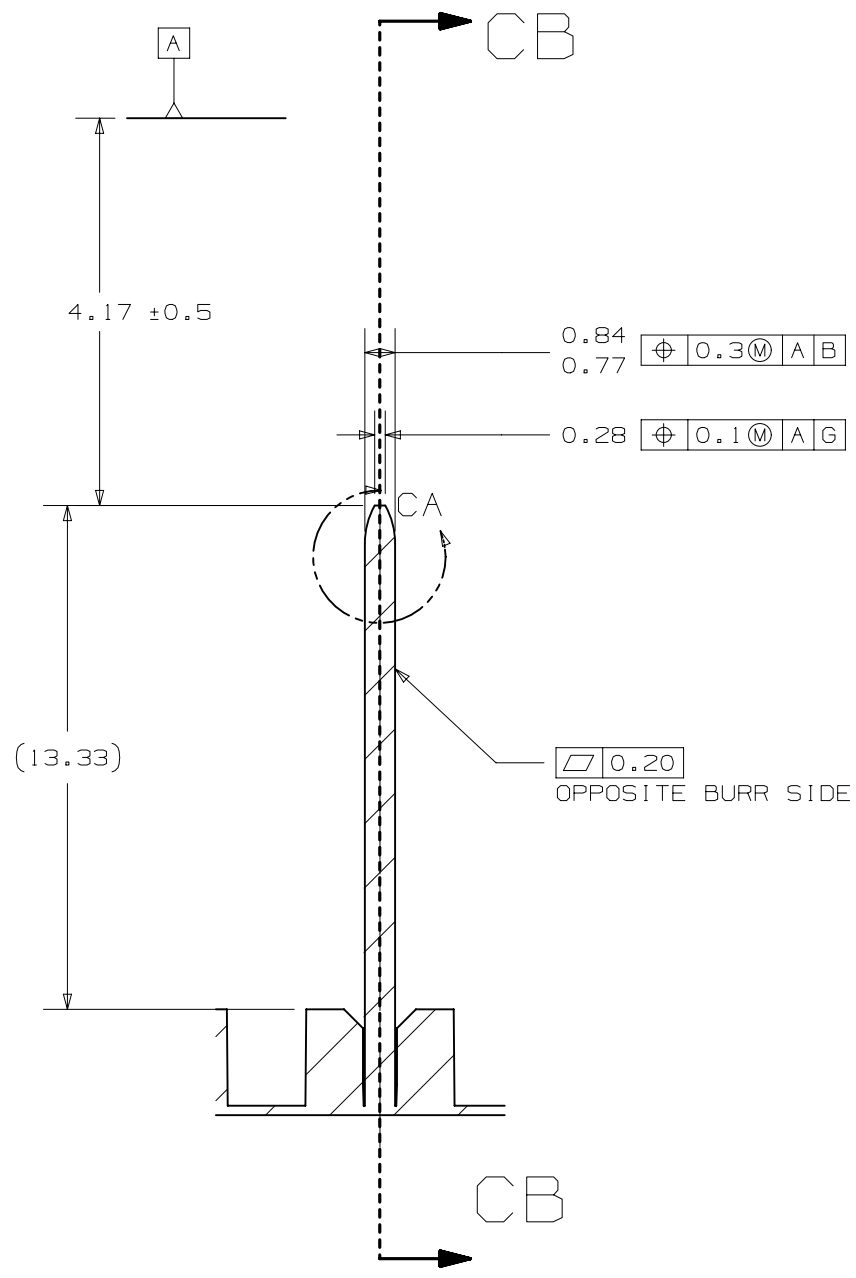

VIEW BY  
SCALE 5:1

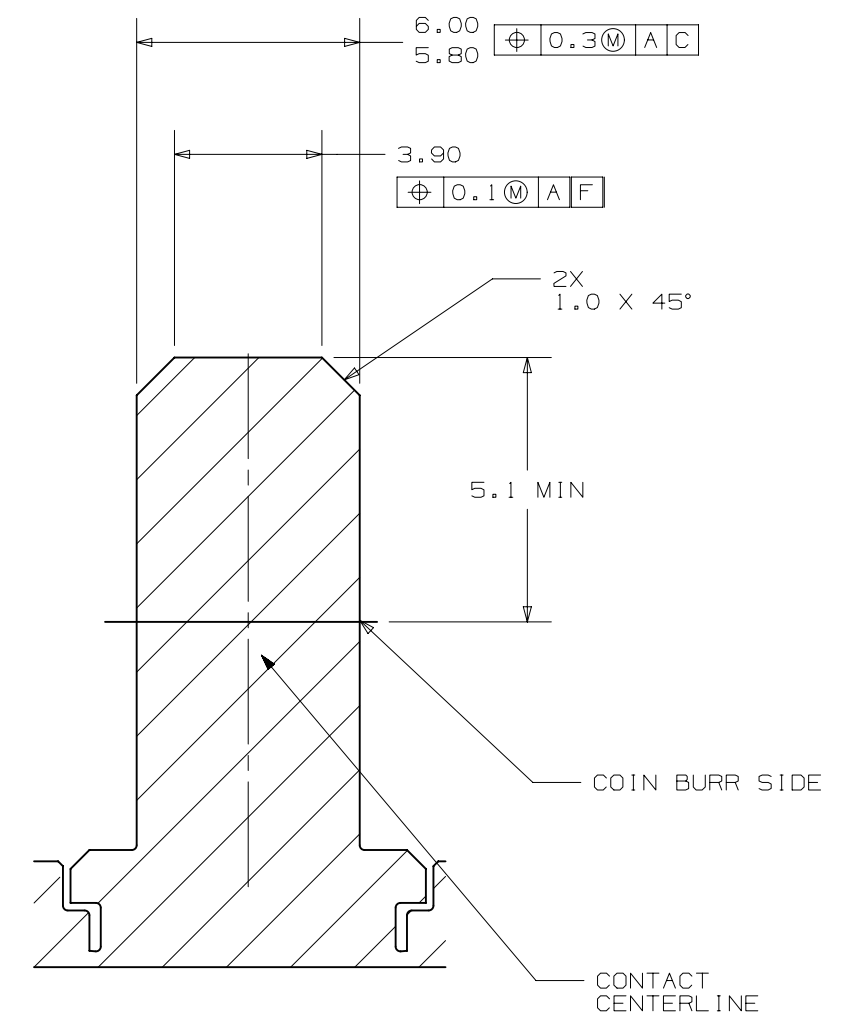

SECTION CB-CB



PAGE TITLE  
COMPONENT CONNECTOR INTERFACE

DRAWING NUMBER  
12672832

DWG STATUS		
ST	REV	PD1
R	001	

PAGE NUMBER  
22 OF 23

MOLEX MX64 RECEPTACLE TERMINAL INFORMATION

ITEM	MOLEX P/N	GM P/N	WIRE SIZE MM2	TYPE	PLATING	REEL WIND DIRECTION	COMMENTS
1	34736-0025		0.35	ISO	SILVER	LEFT	
2	34736-0026	12672850	0.35	ISO	SILVER	RIGHT	
3	34736-0027		0.5 / 0.75	ISO	SILVER	LEFT	
4	34736-0028	12672851	0.5 / 0.75	ISO	SILVER	RIGHT	

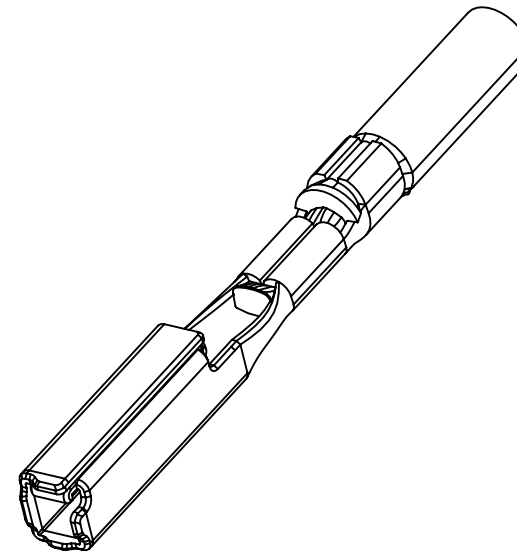
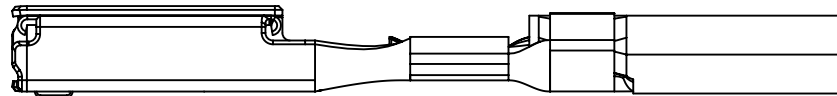
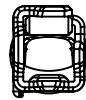

CAVITY PLUGS

ITEM	MFG	MFG P/N	GM P/N RD	SIZE	COLOR	MFG DRAWING	PROD SPEC	APP SPEC	COMMENTS
1	MOLEX	34586-0001	12674820	0.64	NATURAL	SD-34586-001	PS-34566-0000	AS-34566-001	
2	YAZAKI	7158-3114-90	12674821	2.8	BLUE	7158-3114-90	YPES-11-04-062	YPES-15-299	

ITEM 1

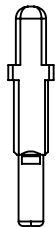
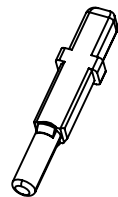

ITEM 2

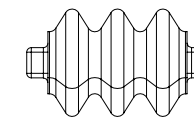
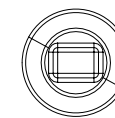

PAGE TITLE  
ADDITIONAL COMPONENTS REQUIRED

DRAWING NUMBER  
12672832

DWG STATUS		
ST	REV	PD1
R	001	

PAGE NUMBER  
23 of 23

INDEX	
PAGE TITLE	PAGE
TITLE BLOCK	1
REVISION BLOCK	2
PART BLOCK	3
KPC BLOCK	4
COMPONENT TABLE	5
NOTES	6
NOTES	7
WIRE DRESS PACKAGING DIMENSIONS	8
LOCATION AND PACKAGING DIMENSIONS REFERENCING INTERFACE DATUMS B & C	9
LOCATION AND PACKAGING DIMENSIONS REFERENCING INTERFACE DATUM A	10
KEY ID REF - WIRE DRESS OPTION 0	11
KEY ID REF - WIRE DRESS OPTION 9	12
CIRCUIT CONFIGURATIONS	13
CIRCUIT CONFIGURATIONS	14
COMPONENT CONNECTOR INTERFACE	15
COMPONENT CONNECTOR INTERFACE	16
COMPONENT CONNECTOR INTERFACE	17
COMPONENT CONNECTOR INTERFACE	18
COMPONENT CONNECTOR INTERFACE	19
COMPONENT CONNECTOR INTERFACE	20
COMPONENT CONNECTOR INTERFACE	21
ADDITIONAL COMPONENTS REQUIRED	22

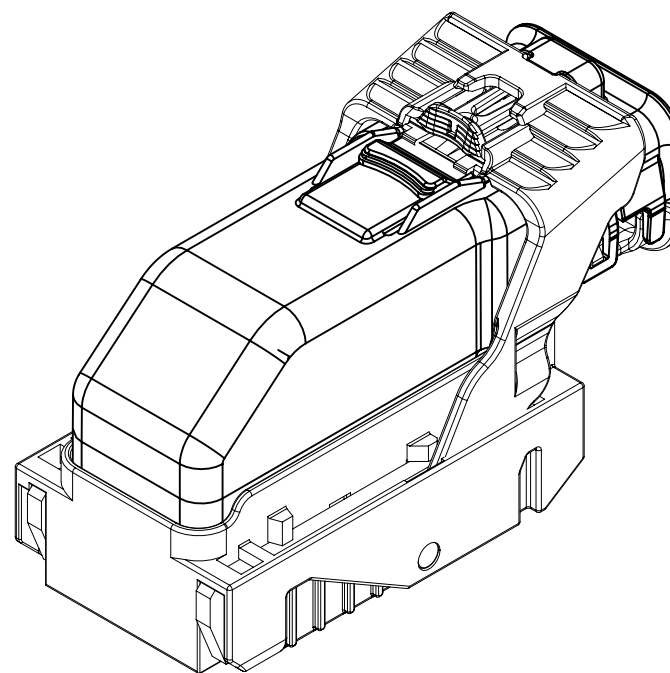

ISO VIEW

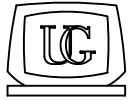
	<p><b>UNLESS OTHERWISE SPECIFIED:</b> THIS DOCUMENT IS IN ACCORDANCE WITH ASME Y14.5M-1994 AS AMMENDED BY THE GM GLOBAL DIMENSIONING AND TOLERANCING ADDENDUM-1997. ALL GEOMETRIC TOLERANCES AND RELATED DATUMS APPLY RFS. RULE #1 (PERFECT FORM AT MMC) DOES NOT APPLY WHEN A RELATIONSHIP BETWEEN FEATURES IS ESTABLISHED BY ORIENTATION OR LOCATION TOLERANCES. SEPARATE POSITION CALLOUTS MAY BE GAGED SEPARATELY REGARDLESS OF DATUM REFERENCES.</p>			DATE
	 CHANGE RESTRICTED NO MANUAL CHANGES	REFERENCE 12H (MOLEX AUTOMOTIVE)	DRAFTER APVD1	05JN15
DO NOT SCALE		APVD2		
METRIC DIMENSIONS SHOWN IN MILLIMETERS UNLESS OTHERWISE SPECIFIED	DRAWING NAME	APVD3		
	HARNESS CONN ASM-SEALED 52/66/73/80 CKTS, MX123	APVD4		
		APVD5		
	DRAWING NUMBER	DWG STATUS		
	12672833	ST	REV	
		R	001	
		PAGE NUMBER		
		1	OF 22	

PAGE	DWG STATUS					REVISION HISTORY	AUTH	DR	CK	ENG
	DATE	ST	REV	CHG	PDI					
	05JN15	R	001			RELEASED TO PRODUCTION AT DLS A	CRMRJE	DFK		

PAGE	DWG STATUS					REVISION HISTORY	AUTH	DR	CK	ENG
	DATE	ST	REV	CHG	PDI					

	PAGE TITLE	DRAWING NUMBER	DWG STATUS			PAGE NUMBER	
	REVISION BLOCK		12672833	ST	REV	PDI	2 OF 22
				R	001		



KEY PRODUCT CHARACTERISTICS  
(IN ACCORDANCE WITH QN 1805 OR ON 1050)



SAFETY/COMPLIANCE

TOTAL ON  
DRAWING

4



FIT/FUNCTION

LAST NO.  
USED

4

NO	TYPE	DESCRIPTION	RATIONALE	PAGE/ZONE
1	F/F	32.68	IMPROVE CONNECTOR SYSTEM MATING	16
2	F/F	29.00	INSURE PROPER RELEASE OF LEVER	16
3	F/F	15.25	INSURE FINAL MATE POSITION	17
4	F/F	POSITIONAL TOLERANCE (2 PLACES)	INSURE CONNECTOR SYSTEM MATEABILITY	20



PAGE TITLE  
KPC BLOCK

DRAWING NUMBER

12672833

DWG STATUS

ST	REV	PDI
----	-----	-----

R	001	
---	-----	--

PAGE NUMBER

4 OF 22



LINE	MFG.	MFG. P/N	GM P/N	EFFECTIVE DATE	APPLICABLE COMPONENTS	KEY OPTION	WIRE DRESS OPTION	KEY CONFIG.	COLOR	STATUS
					DESCRIPTION					
-										
1	MOLEX	34565-0003	12582676	02JN03	MX123 DRESS COVER 52/66/73/80 CKT	N/A	N/A	N/A	BLACK	AVAILABLE
2	MOLEX	160094-0001	12672852	01SP13	MX123 HRNS CONN ASSY 52 CKT	A	0	1458	BLACK	AVAILABLE
3	MOLEX	160094-0003	12672854	01SP13	MX123 HRNS CONN ASSY 52 CKT	C	0	2467	BLUE	AVAILABLE
4	MOLEX	160094-0013	12672853	01SP13	MX123 HRNS CONN ASSY 52 CKT	A	9	1458	BLACK	AVAILABLE
5	MOLEX	160094-0015	12672855	01SP13	MX123 HRNS CONN ASSY 52 CKT	C	9	2467	BLUE	AVAILABLE
6	MOLEX	34822-0013	12672856	01SP13	MX123 HRNS CONN ASSY 66 CKT	A	0	1458	BLACK	AVAILABLE
7	MOLEX	34822-0033	12672858	01SP13	MX123 HRNS CONN ASSY 66 CKT	C	0	2467	BLUE	AVAILABLE
8	MOLEX	34822-0023	12672857	01SP13	MX123 HRNS CONN ASSY 66 CKT	A	9	1458	BLACK	AVAILABLE
9	MOLEX	34822-0043	12672859	01SP13	MX123 HRNS CONN ASSY 66 CKT	C	9	2467	BLUE	AVAILABLE
10	MOLEX	34566-0103	12672860	11JN04	MX123 HRNS CONN ASSY 73 CKT	A	0	1458	BLACK	AVAILABLE
11	MOLEX	34566-0203	12672862	11JN04	MX123 HRNS CONN ASSY 73 CKT	B	0	1468	ST GRAY	AVAILABLE
12	MOLEX	34566-0303	12672864	09AP08	MX123 HRNS CONN ASSY 73 CKT	C	0	2467	BLUE	AVAILABLE
13	MOLEX	34566-0603	12672866	05DC14	MX123 HRNS CONN ASSY 73 CKT	F	0	1357	NATURAL	AVAILABLE
14	MOLEX	34566-1303	12672861	11JN04	MX123 HRNS CONN ASSY 73 CKT	A	9	1458	BLACK	AVAILABLE
15	MOLEX	34566-1403	12672863	11JN04	MX123 HRNS CONN ASSY 73 CKT	B	9	1468	ST GRAY	AVAILABLE
16	MOLEX	34566-1503	12672865	09AP08	MX123 HRNS CONN ASSY 73 CKT	C	9	2467	BLUE	AVAILABLE
17	MOLEX	34566-1803	12672867	05DC14	MX123 HRNS CONN ASSY 73 CKT	F	9	1357	NATURAL	AVAILABLE
18	MOLEX	34566-0703	12672872	09AP08	MX123 HRNS CONN ASSY 80 CKT	G	0	1358	BLUE	AVAILABLE
19	MOLEX	34566-0803	12672870	11JN04	MX123 HRNS CONN ASSY 80 CKT	H	0	2458	ST GRAY	AVAILABLE
20	MOLEX	34566-0903	12672868	T.B.D	MX123 HRNS CONN ASSY 80 CKT	J	0	2457	BLACK	NOT ACTIVE
21	MOLEX	34566-1903	12672873	09AP08	MX123 HRNS CONN ASSY 80 CKT	G	9	1358	BLUE	AVAILABLE
22	MOLEX	34566-2003	12672871	11JN04	MX123 HRNS CONN ASSY 80 CKT	H	9	2458	ST GRAY	AVAILABLE
23	MOLEX	34566-2103	12672869	T.B.D	MX123 HRNS CONN ASSY 80 CKT	J	9	2457	BLACK	NOT ACTIVE
24	MOLEX	34736-0028	12672851	01AU10	MX64 RCPT TERM Ag 0.5mm/0.75mm ISO GAGE B (RIGHT PAYOFF)	N/A	N/A	N/A	N/A	AVAILABLE
25	MOLEX	34736-0026	12672850	01AU10	MX64 RCPT TERM Ag 0.35mm ISO GAGE B (RIGHT PAYOFF)	N/A	N/A	N/A	N/A	AVAILABLE
26	MOLEX	34586-0001	12674820	11JN04	MX123 0.64mm GROMMET PLUG	N/A	N/A	N/A	NATURAL	AVAILABLE
27	YAZAKI	7116-4150-02	12588066	02JN03	2.8mm YESC SEALED FEMALE TERMINAL TIN 0.35mm2-0.50mm2	N/A	N/A	N/A	N/A	NOT ACTIVE
28	YAZAKI	7116-4151-02	12588067	02JN03	2.8mm YESC SEALED FEMALE TERMINAL TIN 0.75mm2-1.0mm2	N/A	N/A	N/A	N/A	NOT ACTIVE
29	YAZAKI	7116-4152-02	12582685	02JN03	2.8mm YESC SEALED FEMALE TERMINAL TIN 1.5mm2-2.5mm2	N/A	N/A	N/A	N/A	AVAILABLE
30	YAZAKI	7158-3111-60	12588068	02JN03	2.8mm CABLE SEAL (wire O.D. range 1.2mm-1.9mm)	N/A	N/A	N/A	GREEN	NOT ACTIVE
31	YAZAKI	7158-3112-70	12588069	02JN03	2.8mm CABLE SEAL (wire O.D. range 1.8mm-2.3mm)	N/A	N/A	N/A	YELLOW	NOT ACTIVE
32	YAZAKI	7158-3113-40	12582686	02JN03	2.8mm CABLE SEAL (wire O.D. range 2.1mm-3.0mm)	N/A	N/A	N/A	WHITE	AVAILABLE
33	YAZAKI	7158-3114-90	12674821	02JN03	2.8mm YESC CAVITY PLUG	N/A	N/A	N/A	BLUE	AVAILABLE
34	MOLEX	63825-8400	N/A	02JN03	MX64 TERM HAND CRIMP TOOL	N/A	N/A	N/A	N/A	AVAILABLE
35	MOLEX	63813-1400	XX019826	02JN03	MX64 TERM SERVICE TOOL	N/A	N/A	N/A	N/A	AVAILABLE
36	MOLEX	63902-5300	N/A	02JN03	MX64 CRIMP APPLICATOR with TOOL KIT 0.5/0.75mm2 PAYOFF DIRECTION D (left payoff) (contact Molex for payoff detail)	N/A	N/A	N/A	N/A	AVAILABLE
37	MOLEX	63902-5370	N/A	02JN03	MX64 APPLICATOR TOOL KIT 0.5/0.75mm2	N/A	N/A	N/A	N/A	AVAILABLE
38	MOLEX	63902-5100	N/A	02JN03	MX64 CRIMP APPLICATOR with TOOL KIT 0.35mm2 PAYOFF DIRECTION D (left payoff) (contact Molex for payoff detail)	N/A	N/A	N/A	N/A	AVAILABLE
39	MOLEX	63902-5170	N/A	02JN03	MX64 APPLICATOR TOOL KIT 0.35mm2	N/A	N/A	N/A	N/A	AVAILABLE
40	SPX	J35616-64	T.B.D.	02JN03	0.64mm PROBE TOOL (for rcpt)	N/A	N/A	N/A	N/A	AVAILABLE
41	SPX	J35616-64A	T.B.D.	02JN03	0.64mm PROBE TOOL WITH EXT (for rcpt)	N/A	N/A	N/A	N/A	AVAILABLE
42	SPX	J35616-65	T.B.D.	02JN03	0.64mm PROBE TOOL WITH EXT (for pin)	N/A	N/A	N/A	N/A	AVAILABLE
43	SPX	J35616-4A	T.B.D.	02JN03	2.8mm PROBE TOOL (for rcpt)	N/A	N/A	N/A	N/A	AVAILABLE
44	YAZAKI	X39899-J374	12094430	02JN03	2.8mm TERM SERVICE TOOL	N/A	N/A	N/A	N/A	AVAILABLE
45	TQI	7000-1006	N/A	15JN15	52 CKT PASS THROUGH ADAPTERS	N/A	N/A	N/A	BLACK	AVAILABLE
46	TQI	7000-1002	N/A	15JN15	66 CKT PASS THROUGH ADAPTERS	N/A	N/A	N/A	BLACK	AVAILABLE
47	TQI	79917-0061	N/A	15JN15	73 CKT PASS THROUGH ADAPTERS	N/A	N/A	N/A	BLACK	AVAILABLE
48	TQI	79917-0066	N/A	15JN15	80 CKT PASS THROUGH ADAPTERS	N/A	N/A	N/A	BLACK	AVAILABLE

\* - MX123 DRESS COVER 52/66/73/80 CKT MATES TO ANY MX123 HARN CONN ASSY SHOWN ON TABLE ABOVE



PAGE TITLE  
COMPONENT TABLE

DRAWING NUMBER

12672833

DWG STATUS

ST REV PDI

R 001

PAGE NUMBER

5 OF 22

NOTES: UNLESS OTHERWISE SPECIFIED

1. MATERIAL FOR INTERFACE:

- A. RESIN:
  - 1. 30% G.F. PBT; 20% MAX. (BY WEIGHT) REGRIND.
  - 2. MATING CONNECTOR INTERFACE PART COLOR MUST BE SAME AS MATCHING KEYED HARNESS CONNECTOR ASSEMBLY.
  - 3. MUST BE VALIDATED FOR INDIVIDUAL DEVICE APPLICATION REQUIREMENTS.
- B. 0.64MM PINS:
  - 1. BASE MATERIAL: COPPER ALLOY; CONDUCTIVITY >= 28% IACS AT 20°C; TENSILE STRENGTH >= 635 N/mm<sup>2</sup>; SURFACE ROUGHNESS R<sub>a</sub> 6 MAX.
  - 2. PLATING FINISH: SILVER (Ag). PLATING TO BE 1.9-3.3 μm ELECTRODEPOSITED SEMI-BRIGHT SILVER OVER 1.25-2.25 μm DUCTILE SULPHAMATE NICKEL PER NOTE 1(D).
  - 3. ANTI-TARNISH: SYNTHETIC HYDROCARBON CONTACT SURFACE FINISH OR EQUIVALENT APPLIED WITHOUT VOID TO CONTACT AREA (MIN 3.7mm FROM PIN TIP).
- C. 2.8MM BLADE:
  - 1. BASE MATERIAL: COPPER ALLOY; CONDUCTIVITY >= 28% IACS AT 20°C; TENSILE STRENGTH >= 350 N/mm<sup>2</sup>; SURFACE ROUGHNESS R<sub>a</sub> 6 MAX.
  - 2. PLATING FINISH: TIN. PLATING TO BE 2.5-5.0 μm ELECTRODEPOSITED TIN, MATTE FINISH OVER 1.25-2.5 μm DUCTILE SULPHAMATE NICKEL PER NOTE 1(D).
- D. PLATING REQUIREMENTS:
  - 1. SILVER PLATING
    - a. 99.5% PURE SEMI-BRIGHT WITH NO ORGANIC BRIGHTNERS OR CHROMATES.
  - 2. NICKEL PLATING
    - a. ELECTRODEPOSITED DUCTILE SULFAMATE NICKEL WITH A NON-BRIGHTENED FINISH. NO ORGANIC OR BRIGHTENING AGENTS SHALL BE ALLOWED.
    - b. SHALL ONLY BE USED AS AN UNDERLYING PLATING AND MAY NOT BE USED AS AN ELECTRICAL CONTACT SURFACE PLATING.
    - c. SHALL BE NODULE FREE WHEN VIEWED AT 10X MAGNIFICATION IN MEASURED IN CONTACT SURFACE AREA PLUS 0.5MM PERIMETER AROUND THE CONTACT SURFACE AREA.
    - d. ALL PLATINGS SHALL HAVE A 1.0% MAXIMUM BY WEIGHT IMPURITIES. IMPURITIES ARE DEFINED AS ALL ELEMENTS NOT THE PRIMARY PLATING OR HARDENING AGENT IF APPLICABLE, AS DETERMINED BY WET CHEMICAL ANALYSIS OR AUGER METHOD. NO SINGLE IMPURITY SHALL EXCEED 0.1% MAXIMUM BY WEIGHT.
  - 3. TESTING
    - a. THICKNESS TO BE MEASURED IN CONTACT SURFACE AREA PLUS 0.5MM PERIMETER AROUND THE CONTACT SURFACE AREA AS DESIGNATED IN THE DRAWING. THICKNESS SHALL BE DETERMINED BY METHOD OF X-RAY (XRF).
    - b. PLATING ADHESION SHALL BE TESTED BY A BEND TEST FOR ALL METALS. THE TEST SAMPLE SHALL BE BENT 90 DEGREES TO DETERMINE DEPOSIT ADHESION. TESTING SHALL BE COMPLETED IN ACCORDANCE WITH ASTM SPEC B571.

2. DESIGN - GENERAL:

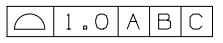
- A. THIS IS A 100% CAD GENERATED PART. THE CAD MATHEMATICAL DATA IS THE MASTER FOR THIS PART. FOR DIMENSIONAL OR ANY INFORMATION NOT SHOWN ON THIS DRAWING, ANALYZE THE CAD MODEL.
- B. TOLERANCES:
  - 1. LINEAR
    - 0.X ± 0.30
    - 0.XX ± 0.10
    - 0.XXX ± 0.10
  - 2. ANGULAR X° ± 3°
  - 3. 
- C. MINIMUM WALL THICKNESS REQUIRED: 1.3mm.
- D. CORNERS SHOWN AS SHARP TO BE R 0.2 MAX.
- E. LETTERING SHALL BE 0.15 MAX RAISED IN 0.20 MAX RECESS PAD. THIS INCLUDES MATERIAL CODE, RECYCLING CODE, CAVITY ID AND DATE CODE.
- F-1. PARTS MUST BE FREE OF DISCOLORATION, SALT RESIDUE AND OTHER IMPERFECTIONS THAT AFFECT FIT OR FUNCTION.
- F-2. SCRATCHES OR DENTS NOT TO EXCEED 0.013mm IN DEPTH.
- G. FOLLOWING PRODUCTION CODES TO BE PERMANENTLY MARKED & HUMAN READABLE TO A LETTER HEIGHT OF 1.5 ± 0.5MM X 0.3 MAX DEEP
  - 1. MATERIAL #: XXXXX-XXXX
  - 2. DATE CODE: JJYY (JULIAN DAY, LAST DIGIT OF YEAR)
  - 3. INSPECTION MACHINE CODE + SERIAL #: X\_XXXXX

3. DESIGN - MANUFACTURING:

- A. DRAFT TO BE WITHIN TOLERANCE.
- B. ALLOWABLE FLASH MAX 0.2 HIGH X MAX 0.13 THICK.
- C. ALLOWABLE PARTING LINE MISMATCH 0.2 MAX.
- D. EJECTOR PINS MARK TO BE FLUSH TO 0.25 MAX DEPRESSED.
- E. ALLOWABLE GATE VESTIGE FLUSH TO 0.25 MAX PROTRUSION.
- F. NO EXTERNAL MOLD RELEASE AGENT ALLOWED DURING MANUFACTURING.
- G. STEEL THAT FORMS THE INDICATED SURFACE MUST BE POLISHED WITH A DIAMOND FINISH (SPI A-2) OVER THE FULL PERIPHERY OF THE TOOL. SURFACE MUST HAVE NO MISMATCH.
- H. ANY PROCESS LUBRICANT REMAINING ON THE TERMINAL MUST NOT VARNISH OR DEGRADE IT'S ELECTRICAL PERFORMANCE UP TO A MAXIMUM CLASS AMBIENT TEMPERATURE PER SAE USCAR-2 FOR 1008 HOURS. PROCESS LUBRICANTS SHOULD BE APPROVED BY THE RESPONSIBLE ENGINEER.
- J. OPTIONAL FEATURES PROVIDED FOR AUTOMATION.
- K. PART MUST BE FREE FROM BURRS AND SHARP EDGES, WHICH MIGHT BE DETRIMENTAL TO SATISFACTORY ASSEMBLY, SAFE HANDLING OR FUNCTION OF PART.
- L. PARTS AS DELIVERED TO ASSEMBLY SHALL BE CLEAN AND FREE OF DEBRIS, RESIDUAL ABRASIVE MATERIAL AND CORROSION PRODUCTS ADVERESLY AFFECTING FUNCTION OR APPEARENCE.
- M. RESTRICTED AND REPORTABLE SUBSTANCES FOR PARTS PER GMW3059.

	PAGE TITLE	DRAWING NUMBER	DWG STATUS			PAGE NUMBER	
	NOTES		12672833	ST	REV	PDI	6 OF 22
				R	001		

NOTES: UNLESS OTHERWISE SPECIFIED

4. SYSTEM REQUIREMENTS:

- A. HARNESS CONNECTOR IS COMPATIBLE WITH THE FOLLOWING ISO WIRE SIZE NO'S:  
 0.35mm<sup>2</sup>, MEETING GMW15626 - MIN OD OF 1.30MM  
 0.50mm<sup>2</sup>, MEETING GMW15626  
 0.75mm<sup>2</sup>, MEETING GMW15626 - MAX OD OF 2.06MM

B. CABLE TIE SPECIFICATIONS:

1. CABLE TIE:  
 TENSILE RATING: 220N / (50lbs) MIN  
 TIE LENGTH: 186mm MIN  
 TIE WIDTH: 4.75mm MAX  
 MATERIAL: NYLON  
 2. INSTALLATION:  
 CABLE TIE TENSION: 190N MIN  
 3. DRESSED WIRE BUNDLE PACKAGING: SEE FIG. 1

C. WHEN MATED WITH COMPONENT CONNECTOR INTERFACE AND/OR DRESS COVER, HARNESS CONNECTOR SYSTEM CONFORMS TO THE FOLLOWING:

1. SAE/USCAR-2, REV: 3 APRIL, 2001; CLASS 3  
 2. FIELD CORRELATED LIFE TEST, SAE/USCAR-20, NOV. 2001  
 3. GMW #3191 AUGUST 22, 2000 (DRAFT); TEMPERATURE CLASS 3, SEALING CLASS 1, VIBRATION CLASS 2  
 4. RESTRICTED AND REPORTABLE CHEMICALS PER GMW #3059, REV: D AUGUST 2002  
 5. TPA USER FORCES (FULLY POPULATED WITH TERMINALS)  
 a. REMOVAL FROM LOCK TO PRE-SET: <=120N

D. WIRE SPECIFICATIONS:

1. WIRE SURFACE MUST BE FREE OF SCRATCHES, GROOVES OR DENTS WHERE FUNCTIONAL

5. TERMINAL CURRENT RATINGS:

A. MX64 RCPT TERM

ALL TESTING DONE IN ACCORDANCE WITH USCAR-2 REV5 SECTION 5.3

1. MX64 RCPT TERM Ag 0.50/0.75mm<sup>2</sup> CRIMPED TO 0.75mm<sup>2</sup> ISO WIRE AND MATED TO MX123 0.64MM PIN: SEE TABLE BELOW  
 2. MX64 RCPT TERM Ag 0.35mm<sup>2</sup> CRIMPED TO 0.35mm<sup>2</sup> ISO WIRE AND MATED TO MX123 0.64MM PIN: SEE TABLE BELOW

WIRE	CURRENT RATING			
	23°C	85°C	105°C	125°C
0.75mm <sup>2</sup>	11.3A	11.3A	9.5A	6.6A
0.50mm <sup>2</sup>	10.0A	10.0A	8.3A	5.7A
0.35mm <sup>2</sup>	8.5A	8.5A	7.1A	5.0A

B. 2.8MM RCPT TERM

ALL TESTING DONE IN ACCORDANCE WITH MOLEX DVP&R 0279 (TR # 7125)

1. 2.8MM RCPT TERM TIN 2.0mm<sup>2</sup> CRIMPED TO 2.0mm<sup>2</sup> ISO WIRE AND MATED TO MX123 2.8MM BLADE: 25.6 AMPS AT 125°C

6. CONTACT MOLEX AUTOMOTIVE FOR AVAILABLE CUSTOM PATTERNS OF CAVITIES OPEN FOR CIRCUITS - SEE GM DRAWING 13507496



PAGE TITLE  
NOTES

DRAWING NUMBER

12672833

DWG STATUS

ST	REV	PDI
R	001	

PAGE NUMBER

7 OF 22

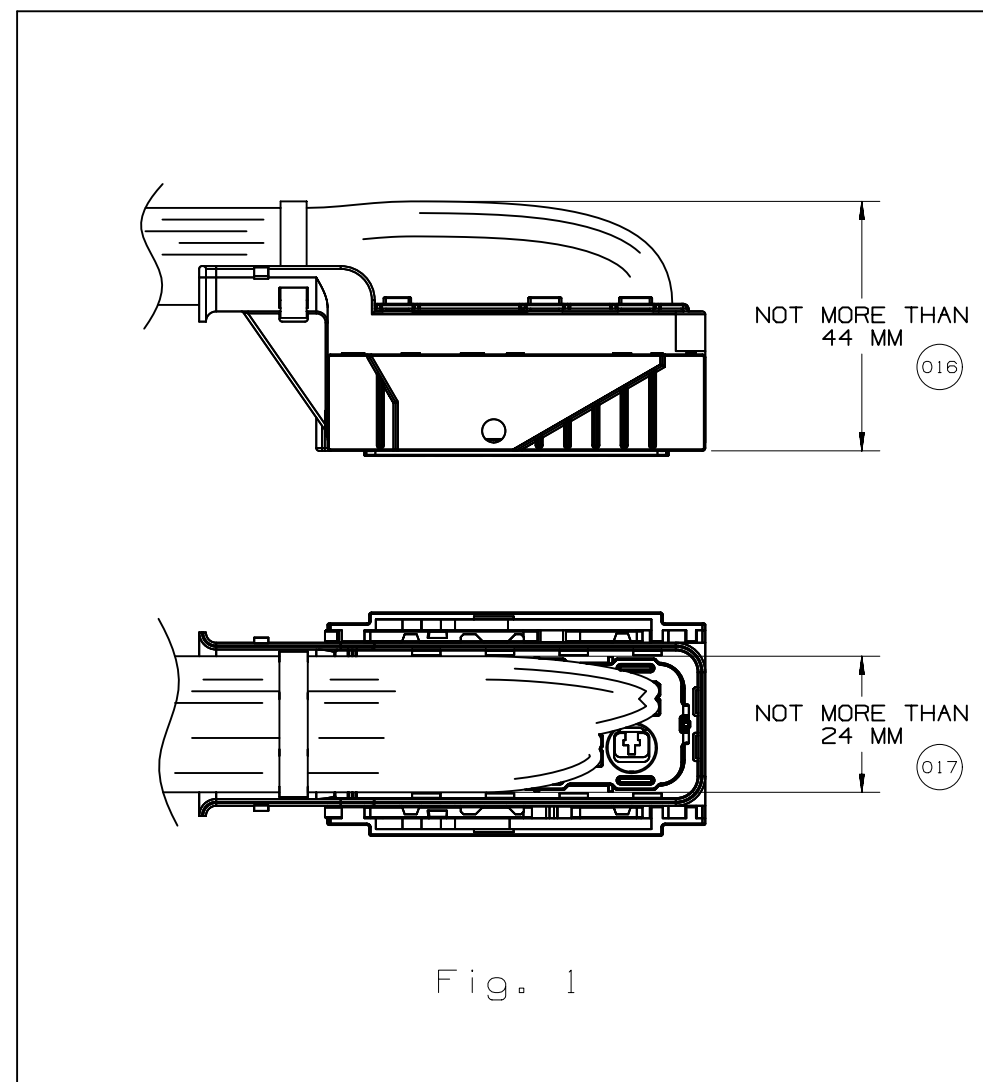
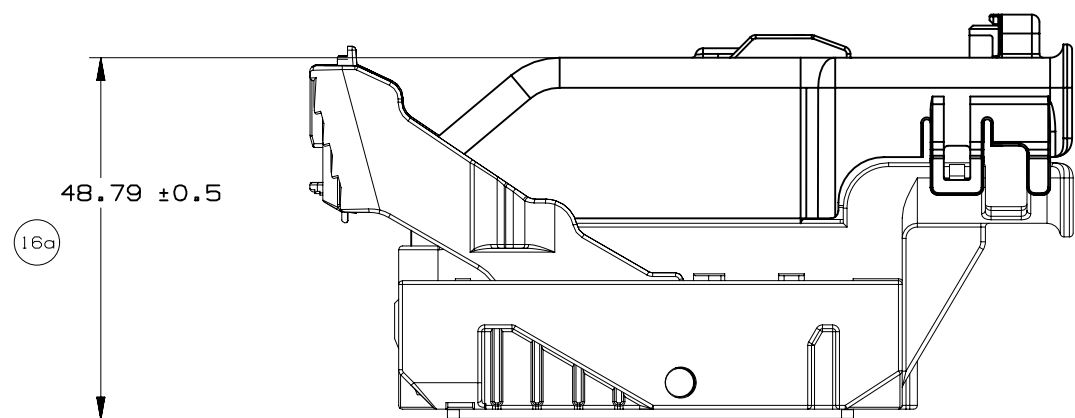

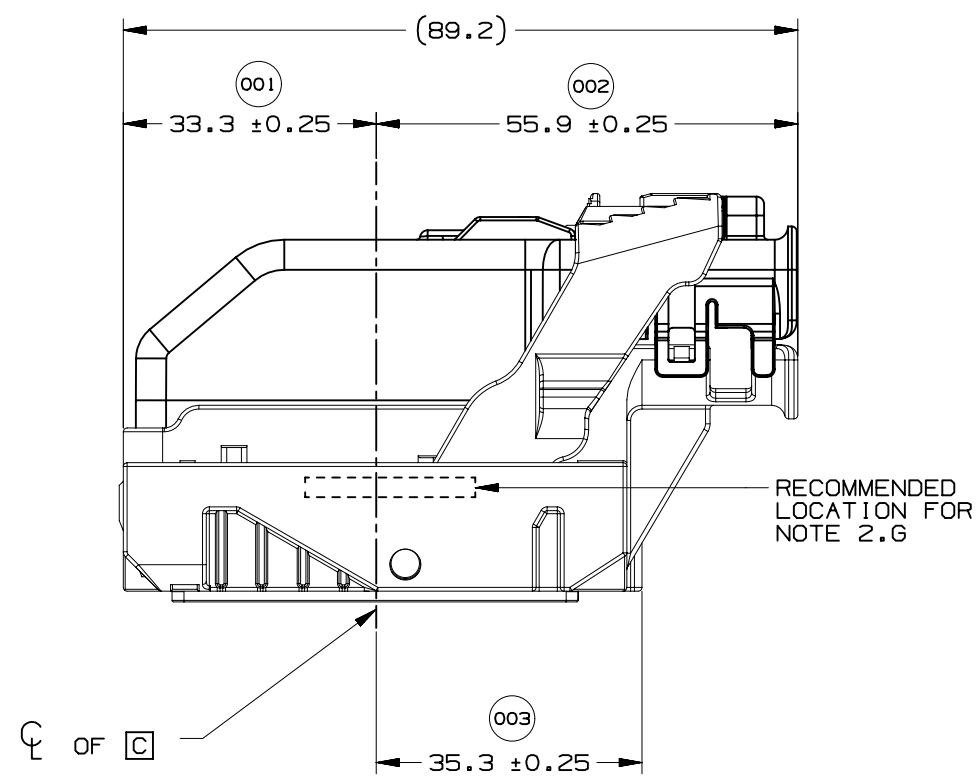

WIRE DRESS OPTION 0 SHOWN

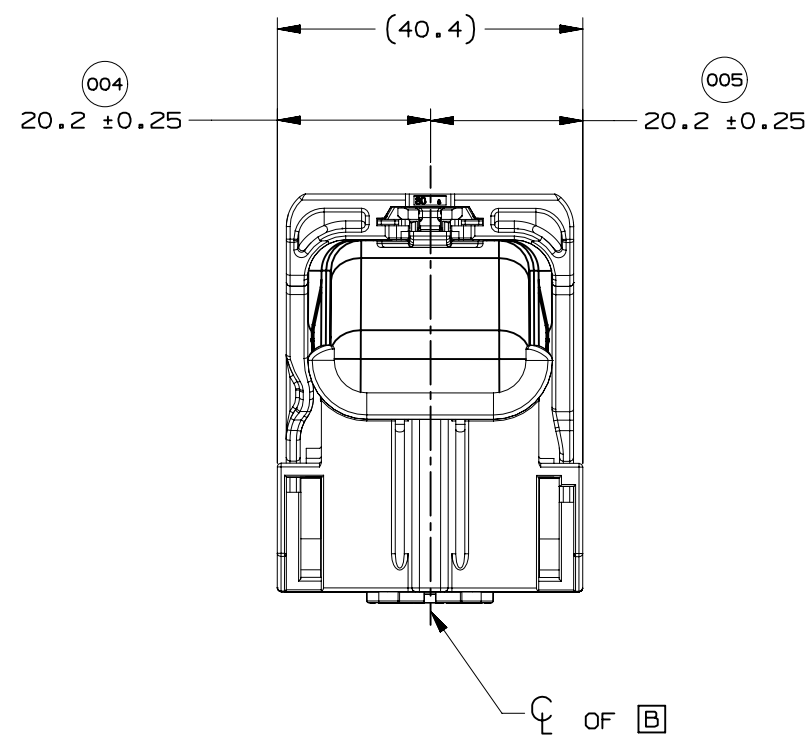

WIRE DRESS OPTION 0 SHOWN

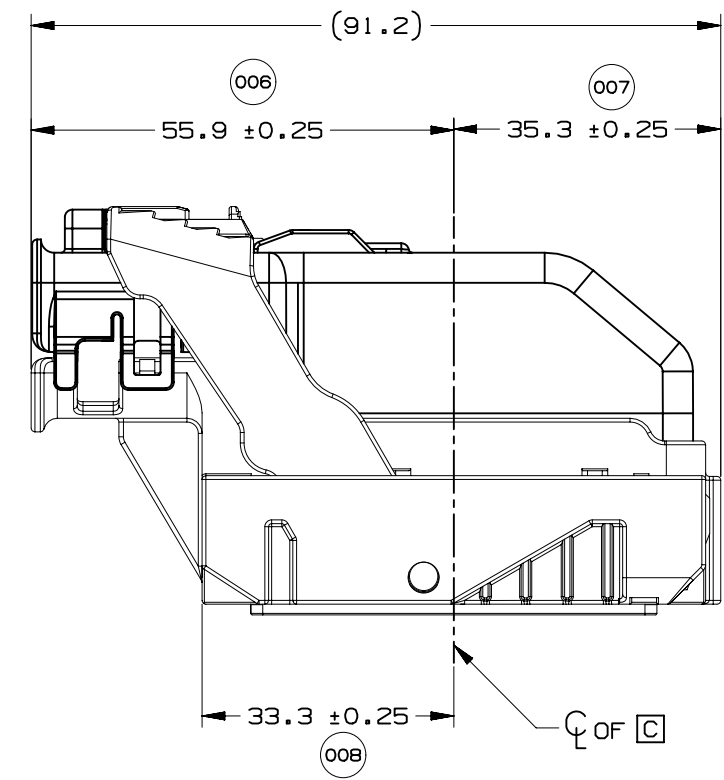

WIRE DRESS OPTION 9 SHOWN



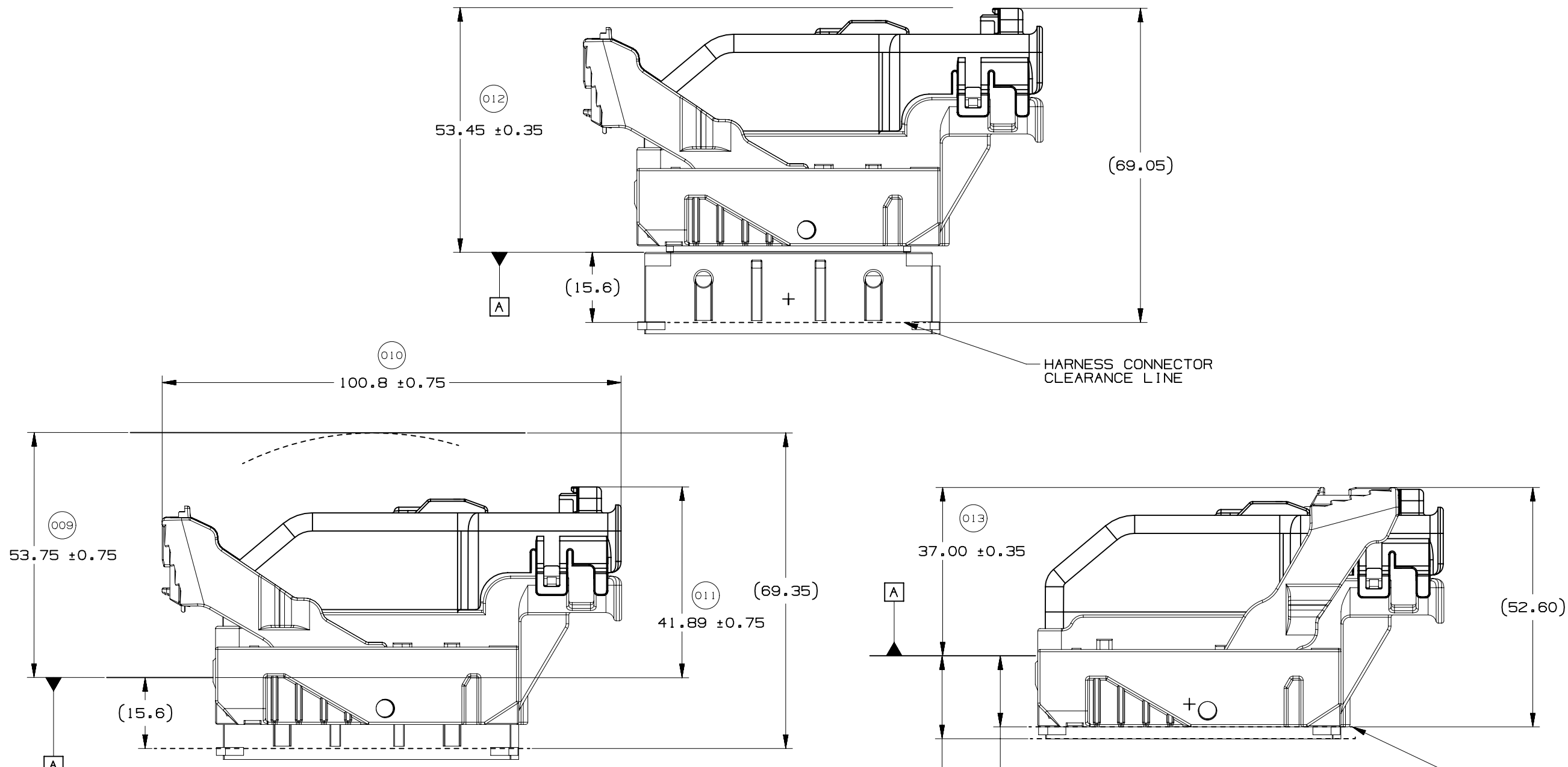

HARNESS CONNECTOR CLEARANCE LINE

HARNESS CONNECTOR ASSEMBLY IN FULLY-MATED POSITION

HARNESS CONNECTOR CLEARANCE LINE

15.6 MIN. ALL AROUND CLEARANCE REQUIRED FOR HARNESS CONNECTOR

17.9 MIN. AT PAD LOCATION CLEARANCE REQUIRED FOR HARNESS CONNECTOR CONSTRUCTION BELOW THIS PLANE IS NOT CONTROLLED



PAGE TITLE  
 LOCATION AND PACKAGING DIMENSIONS  
 REFERENCING INTERFACE DATUM A

DRAWING NUMBER  
 12672833

DWG STATUS		
ST	REV	PD1
R	001	

PAGE NUMBER  
 10 OF 22

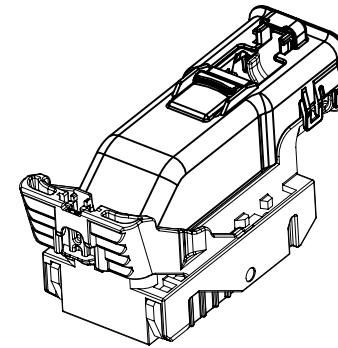
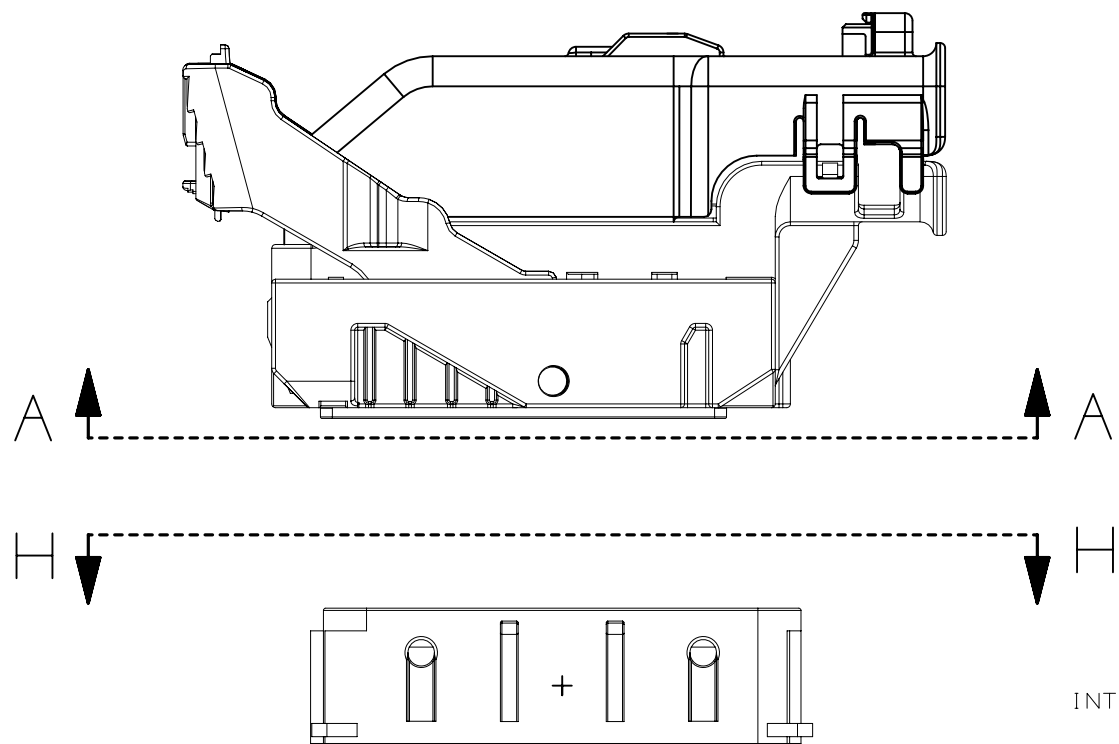

NOTE: REFERENCE THE COMPONENT TABLE FOR KEY OPTIONS AND CONFIGURATIONS

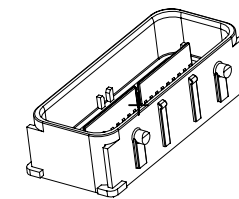

INTERFACE SIDE SHOWN ON ALL SECTION VIEWS

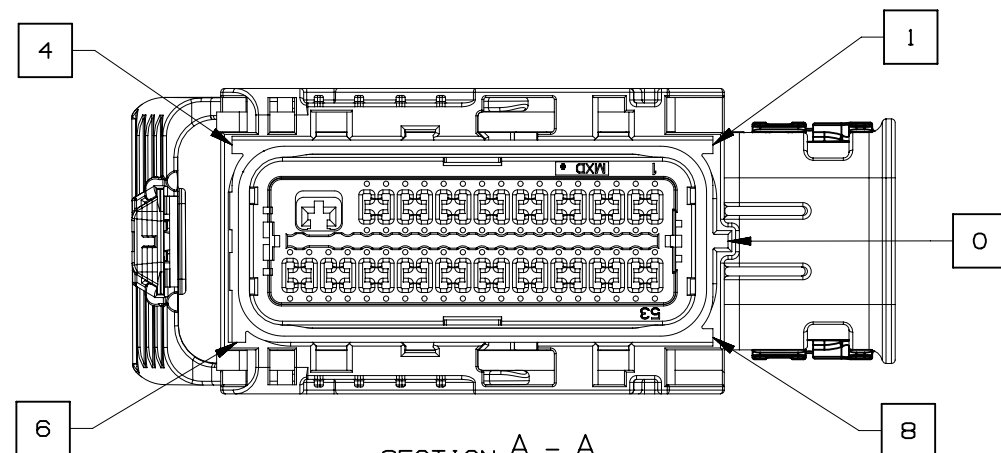

SECTION A - A  
73 CKT HARNESS CONNECTOR ASSEMBLY  
KEY OPTION B SHOWN

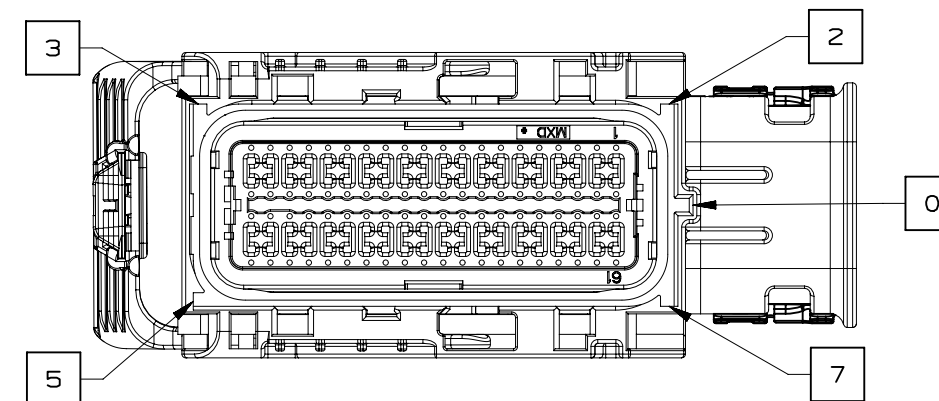

SECTION A - A  
80 CKT HARNESS CONNECTOR ASSEMBLY  
KEY OPTION K SHOWN

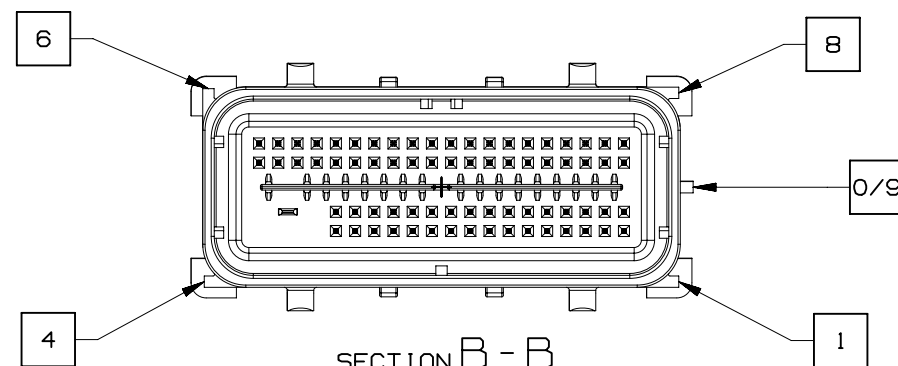

SECTION B - B  
73 CKT HARNESS CONNECTOR ASSEMBLY  
KEY OPTION B SHOWN

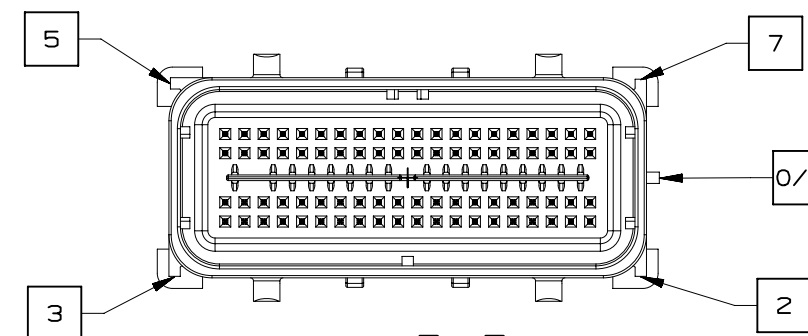

SECTION B - B  
80 CKT HARNESS CONNECTOR ASSEMBLY  
KEY OPTION K SHOWN



PAGE TITLE  
KEY ID REF - WIRE DRESS OPTION 0

DRAWING NUMBER  
12672833

DWG STATUS		
ST	REV	PD1
R	001	

PAGE NUMBER  
11 OF 22

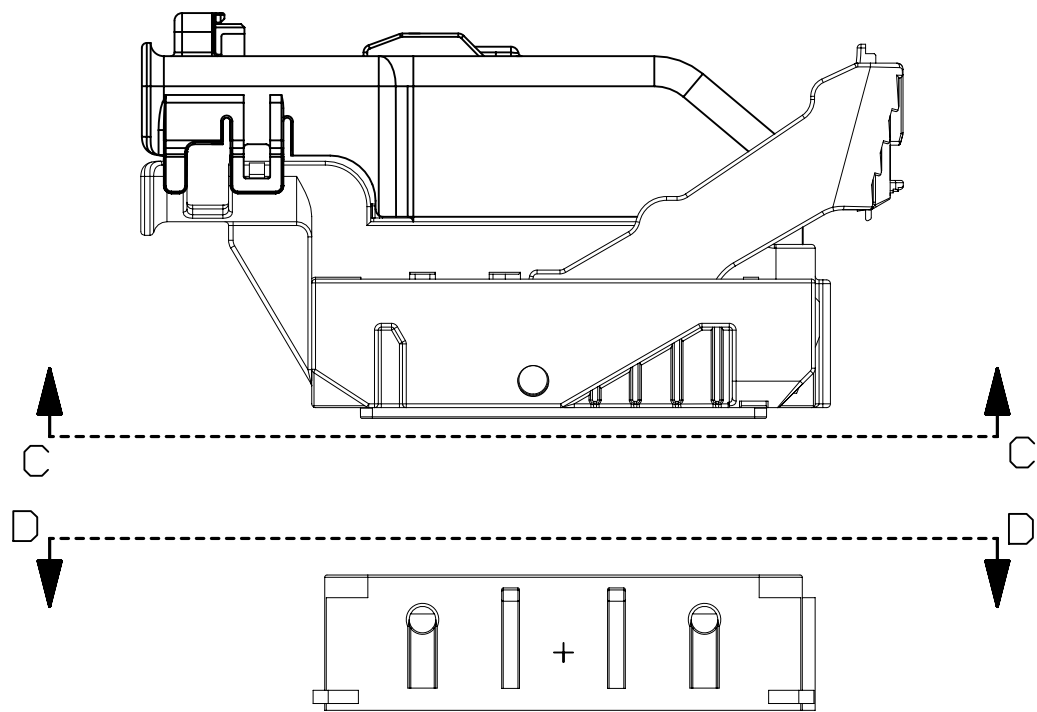

INTERFACE SIDE SHOWN ON ALL SECTION VIEWS

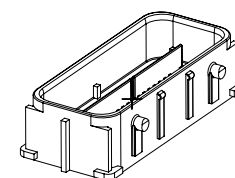
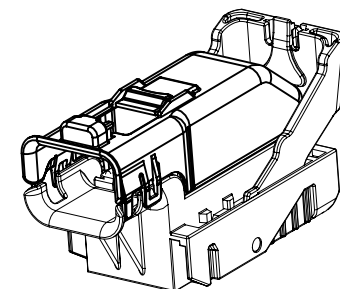

NOTE: REFERENCE THE COMPONENT TABLE FOR KEY OPTIONS AND CONFIGURATIONS

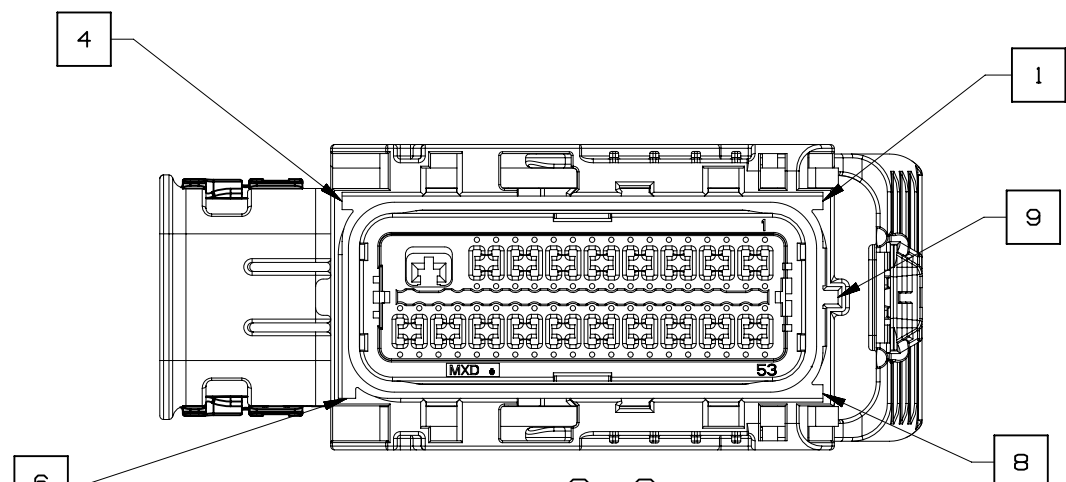

SECTION C - C  
73 CKT HARNESS CONNECTOR ASSEMBLY  
KEY OPTION B SHOWN

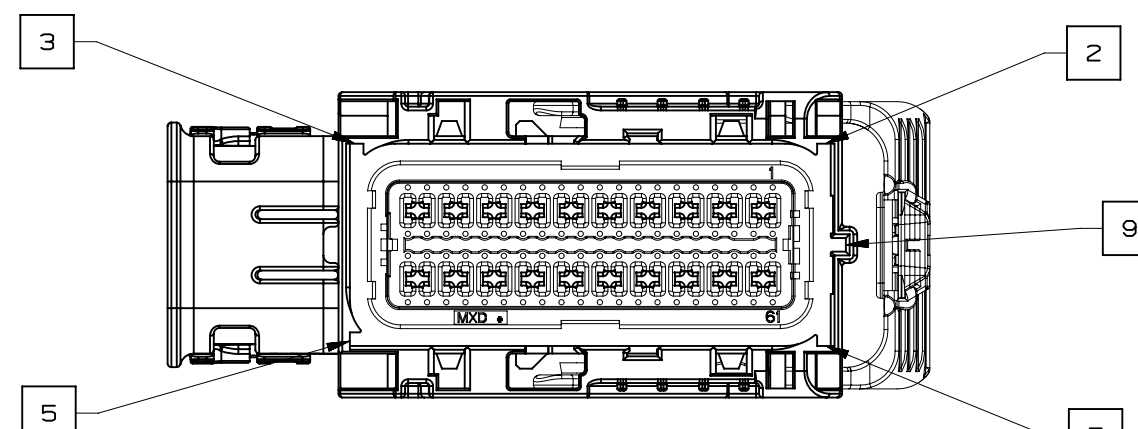

SECTION C - C  
80 CKT HARNESS CONNECTOR ASSEMBLY  
KEY OPTION K SHOWN

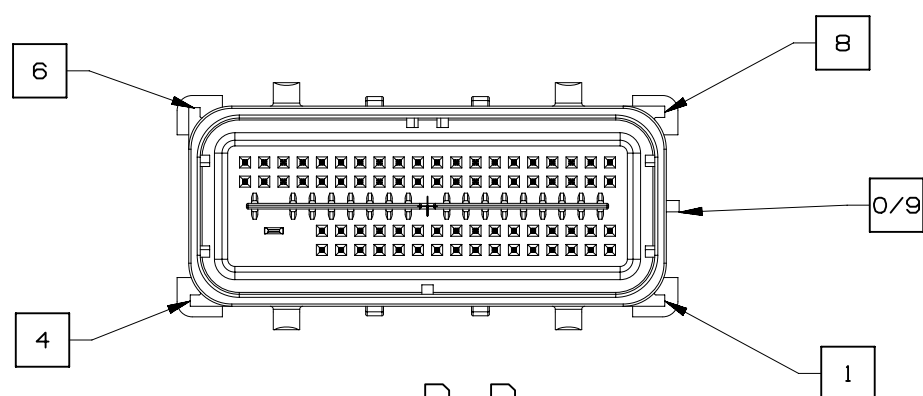

SECTION D - D  
73 CKT HARNESS CONNECTOR ASSEMBLY  
KEY OPTION B SHOWN

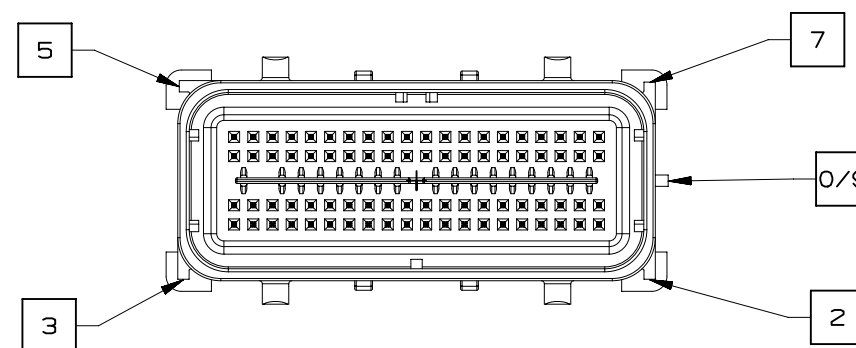

SECTION D - D  
80 CKT HARNESS CONNECTOR ASSEMBLY  
KEY OPTION K SHOWN



PAGE TITLE  
KEY ID REF - WIRE DRESS OPTION 9

DRAWING NUMBER  
12672833

DWG STATUS			PAGE NUMBER
ST	REV	PD1	
R	001		12 OF 22



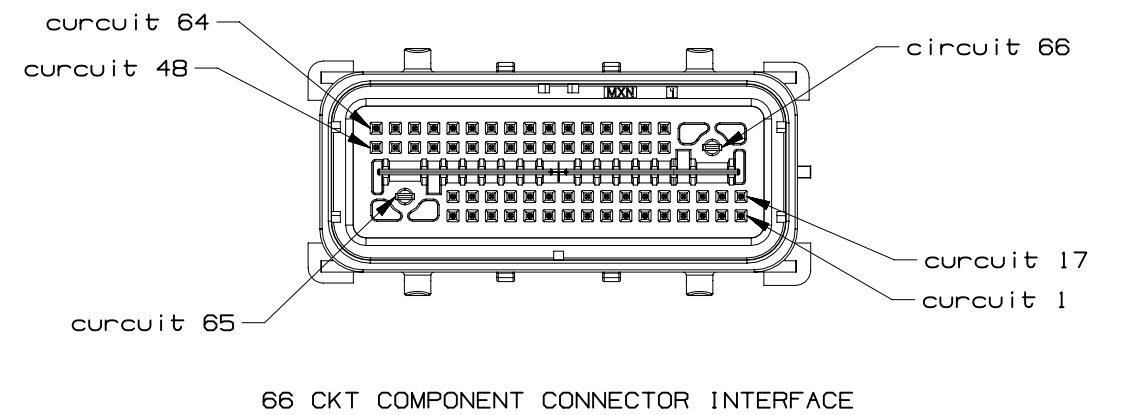
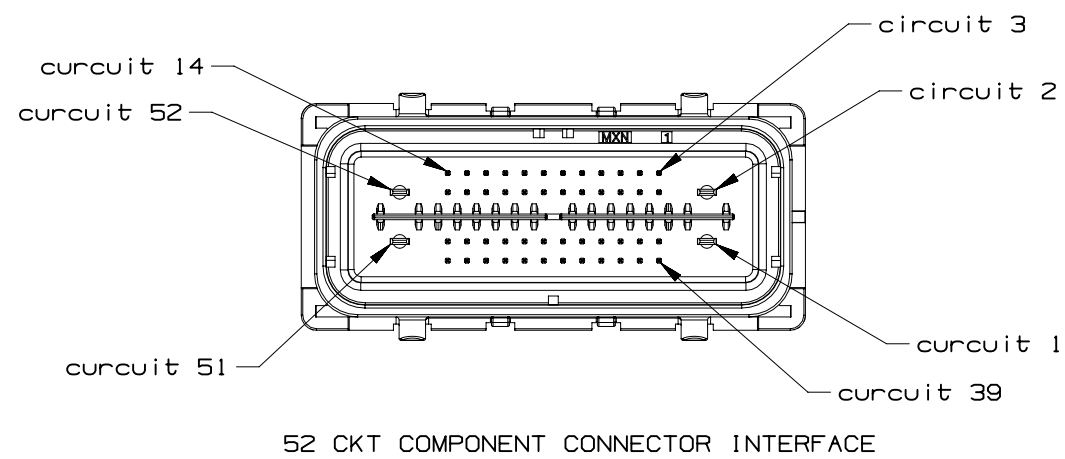
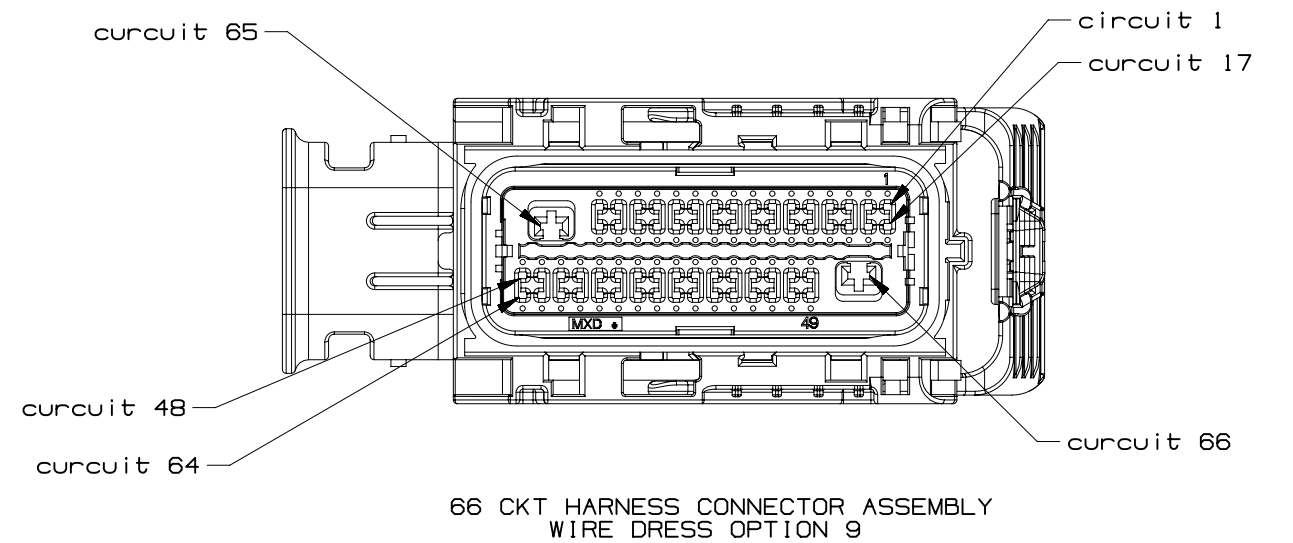
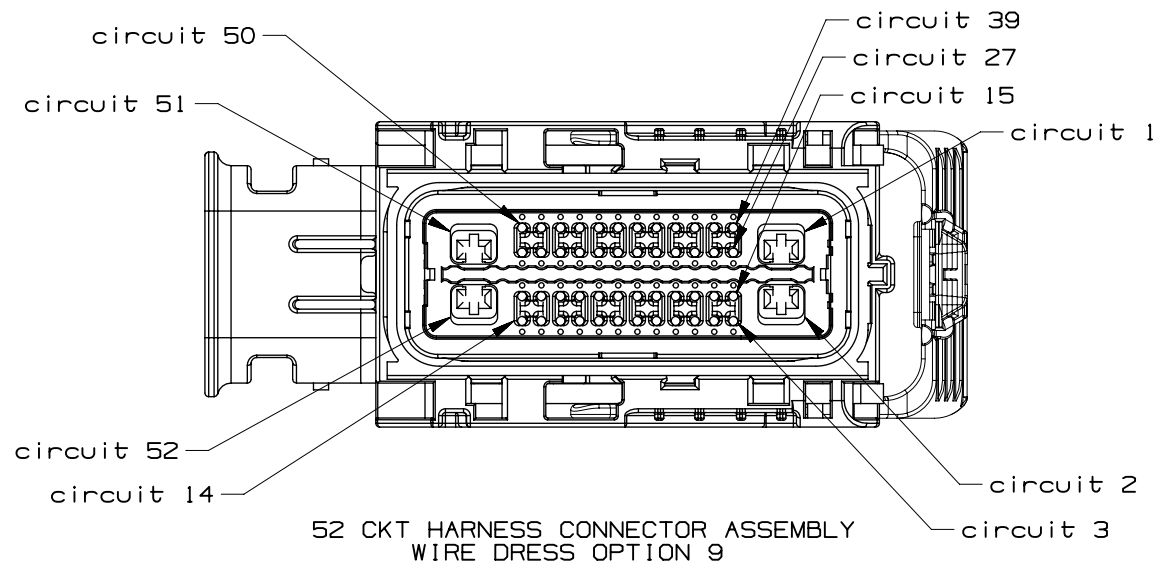
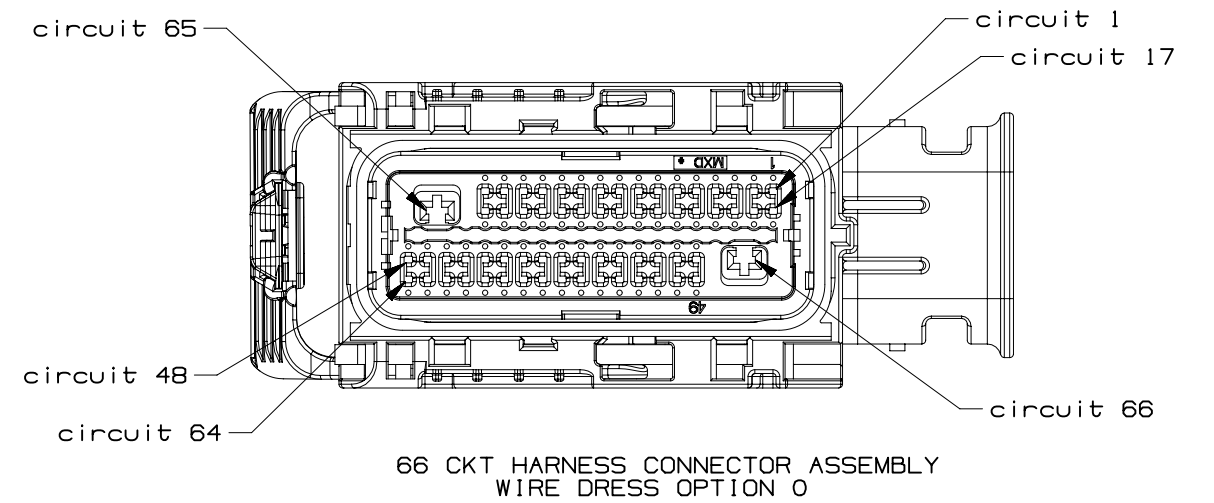
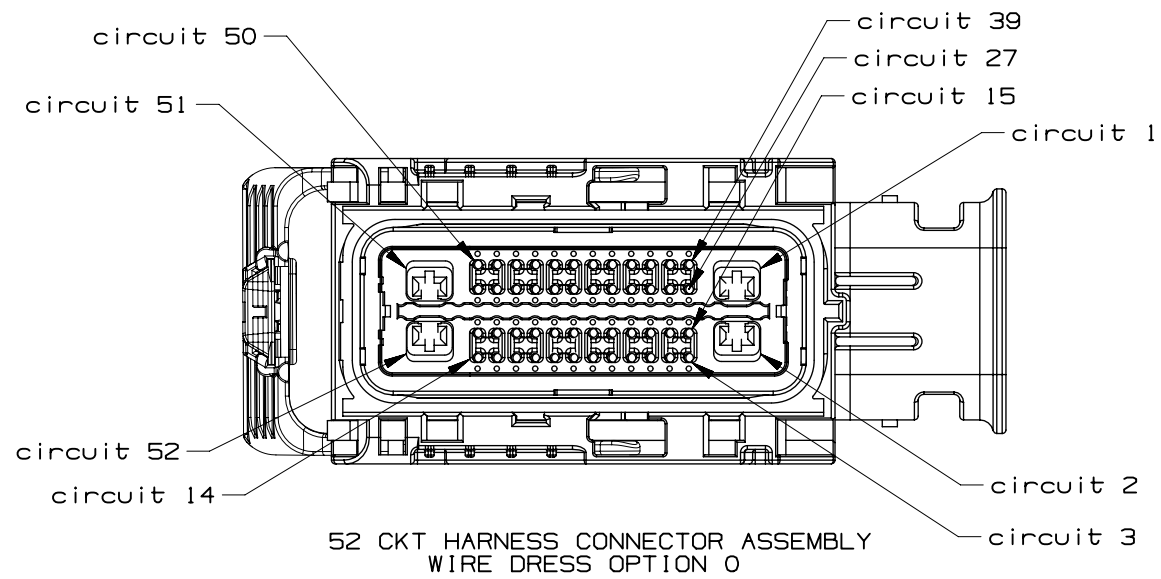

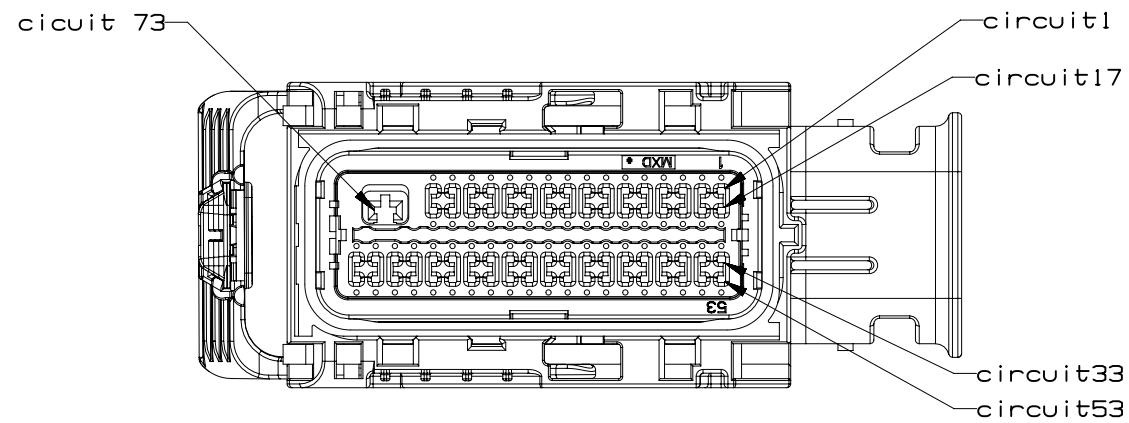

73 CKT HARNESS CONNECTOR ASSEMBLY  
WIRE DRESS OPTION 0

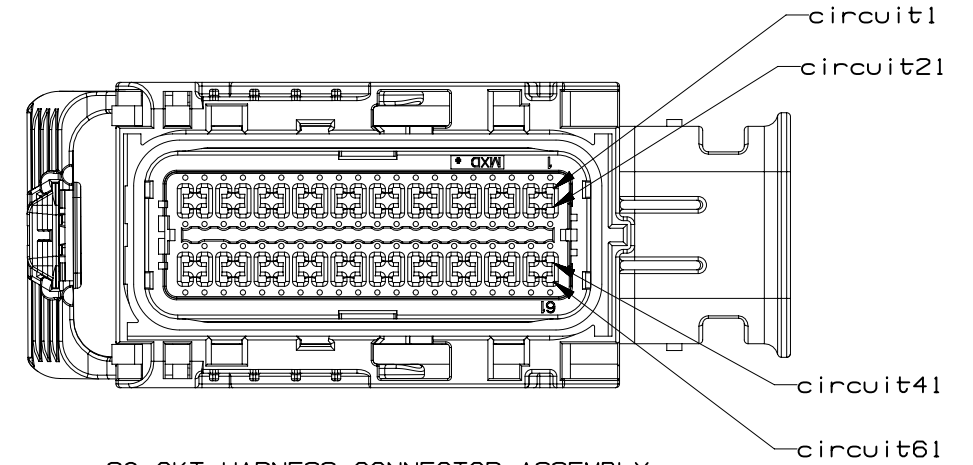

80 CKT HARNESS CONNECTOR ASSEMBLY  
WIRE DRESS OPTION 0

INTERFACE SIDE SHOWN ON ALL VIEWS

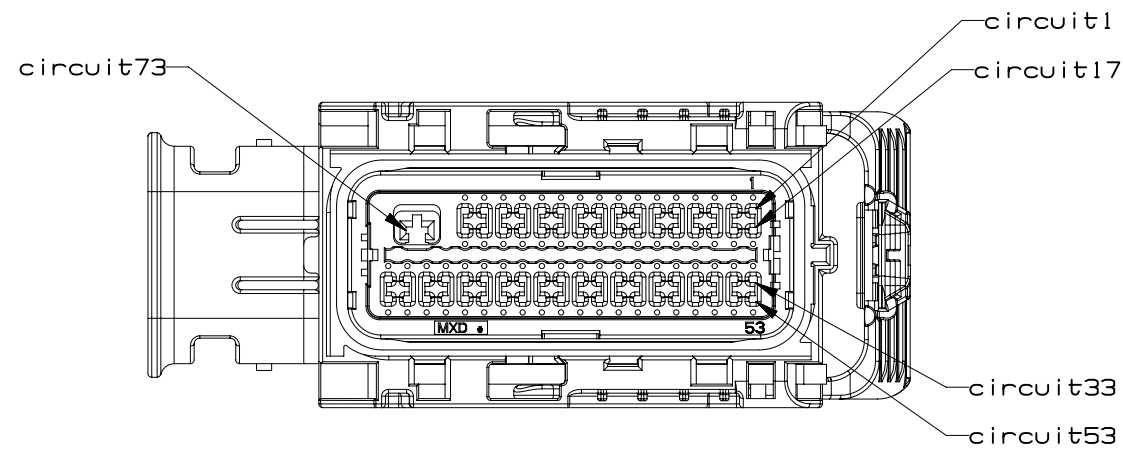

73 CKT HARNESS CONNECTOR ASSEMBLY  
WIRE DRESS OPTION 9

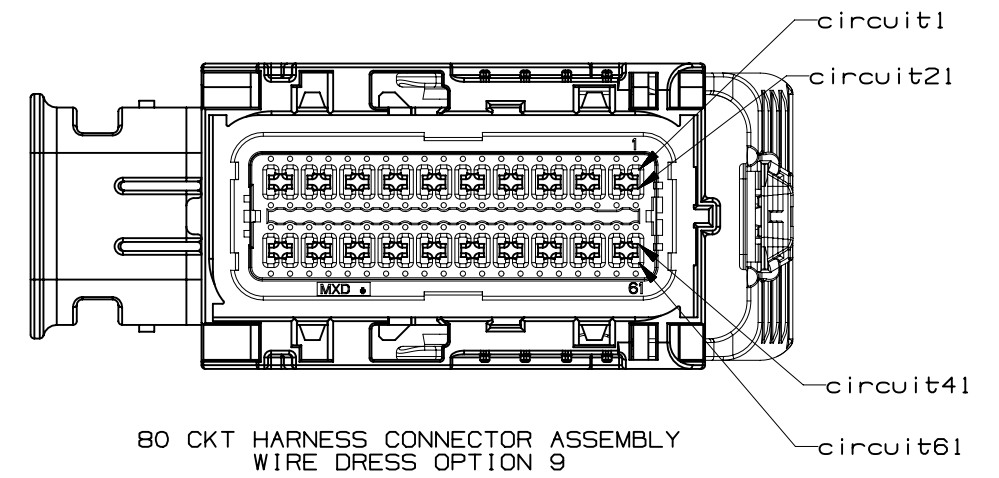

80 CKT HARNESS CONNECTOR ASSEMBLY  
WIRE DRESS OPTION 9

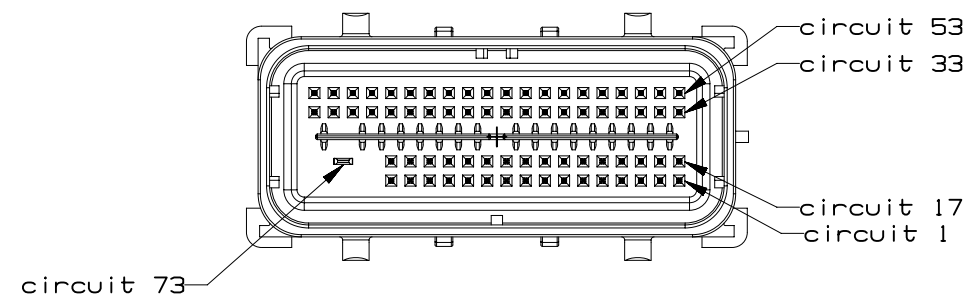

73 CKT COMPONENT CONNECTOR INTERFACE

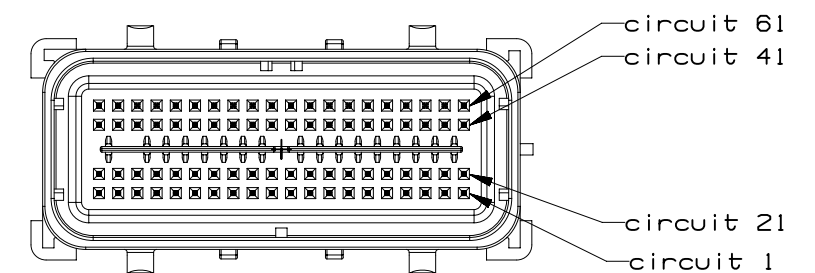

80 CKT COMPONENT CONNECTOR INTERFACE



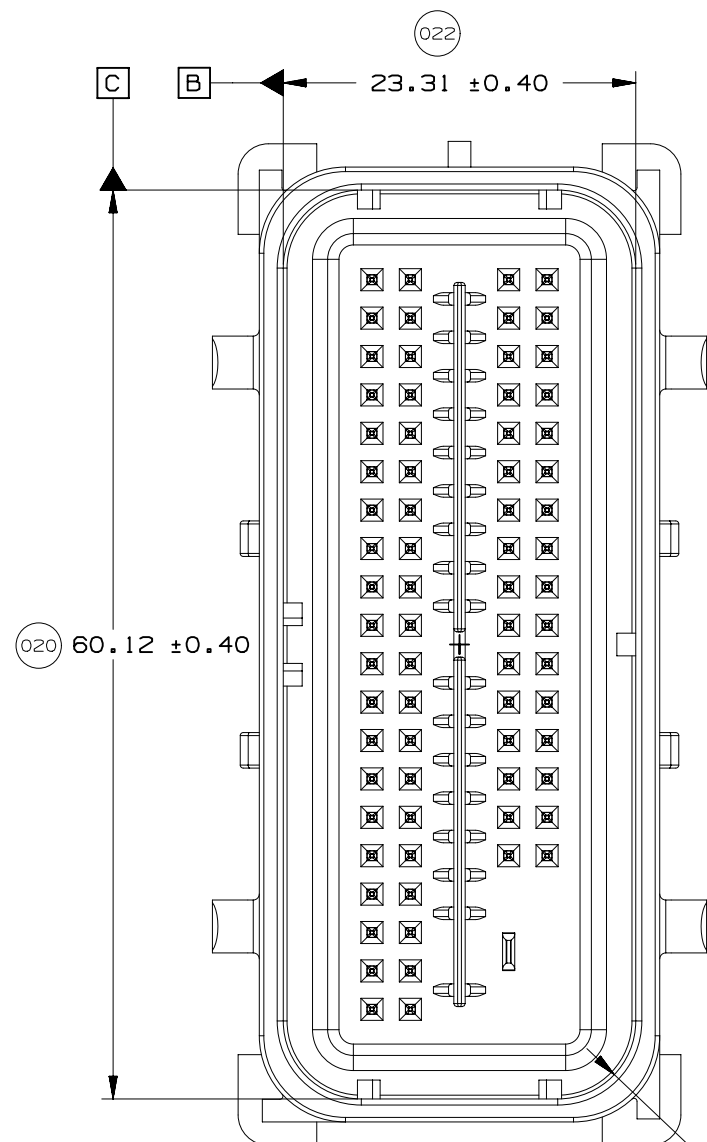
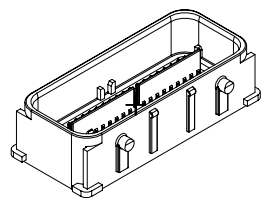

4X R5.16 ± 0.30

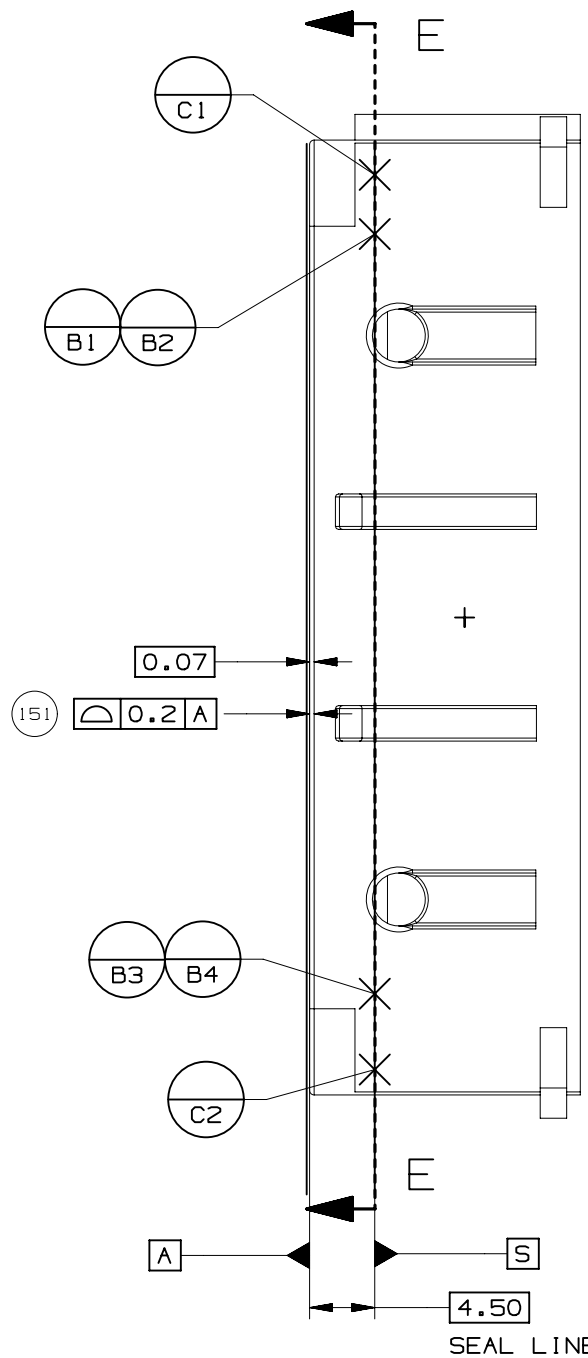

SEAL LINE

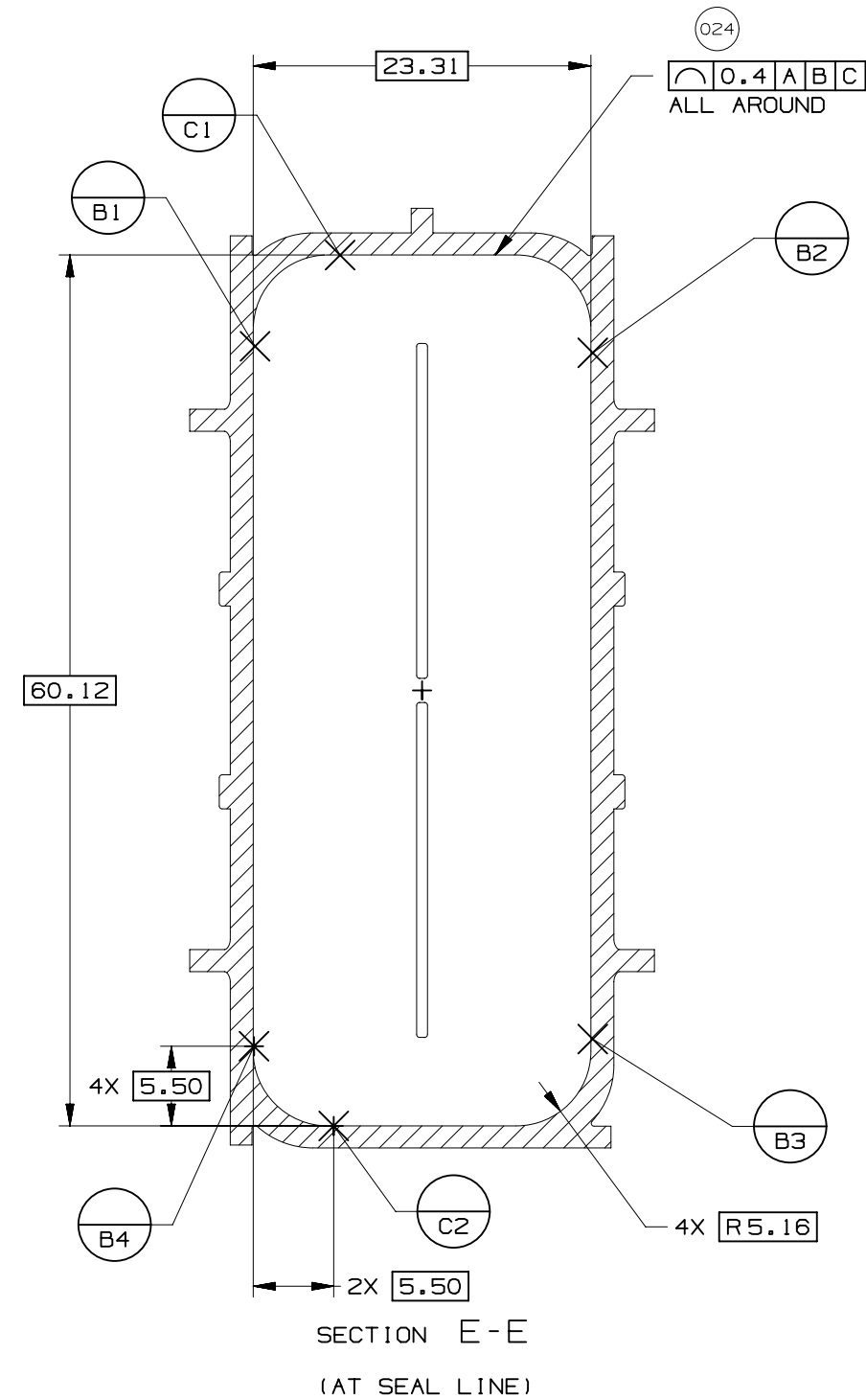

SECTION E-E  
(AT SEAL LINE)

UNLESS SPECIFIED, TOLERANCE OF THE COMPONENT CONNECTOR INTERFACE TO BE  $\sqrt[0.13]{A B C}$



PAGE TITLE  
COMPONENT CONNECTOR INTERFACE

DRAWING NUMBER  
12672833

DWG STATUS			PAGE NUMBER
ST	REV	PD1	
R	001		15 OF 22

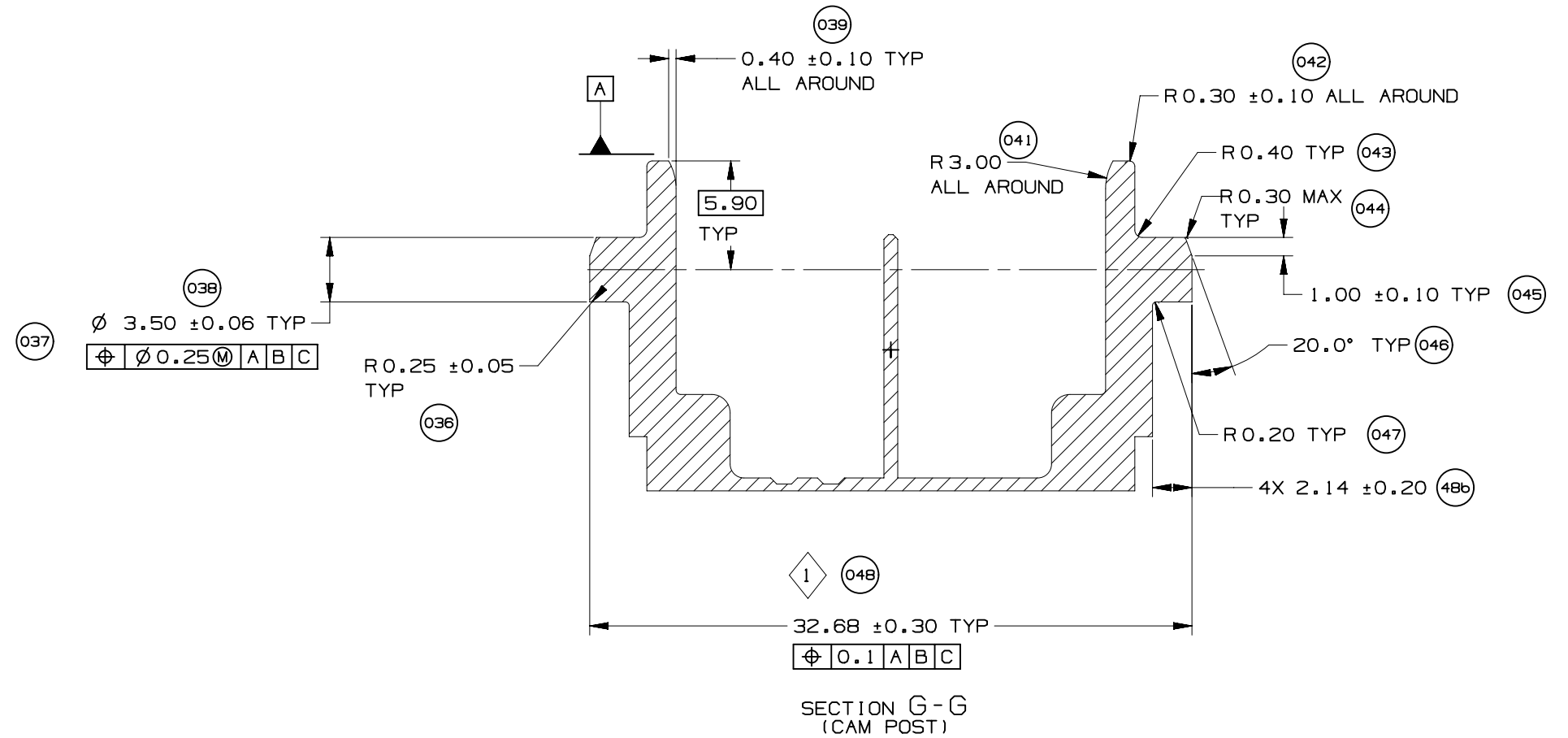
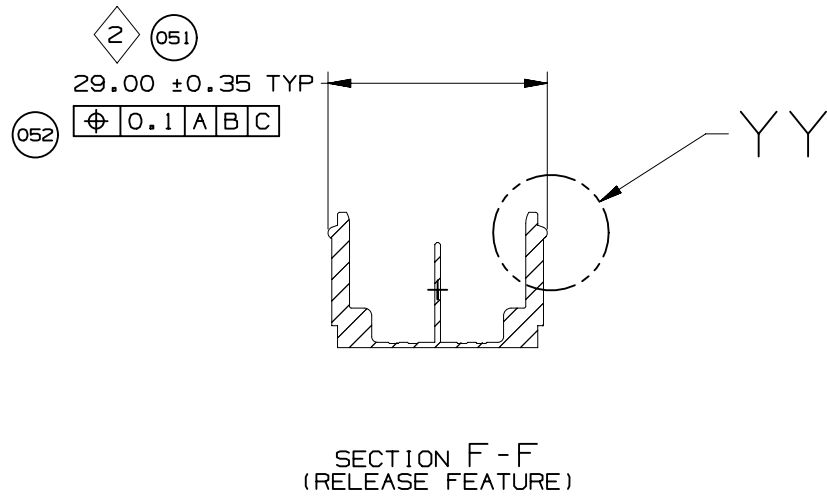
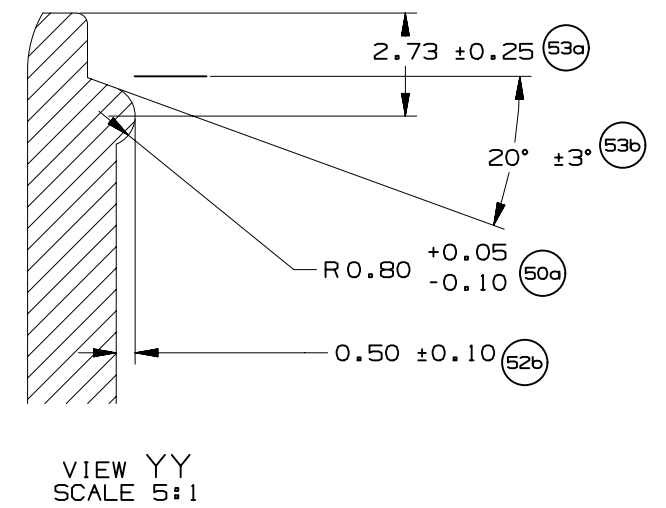
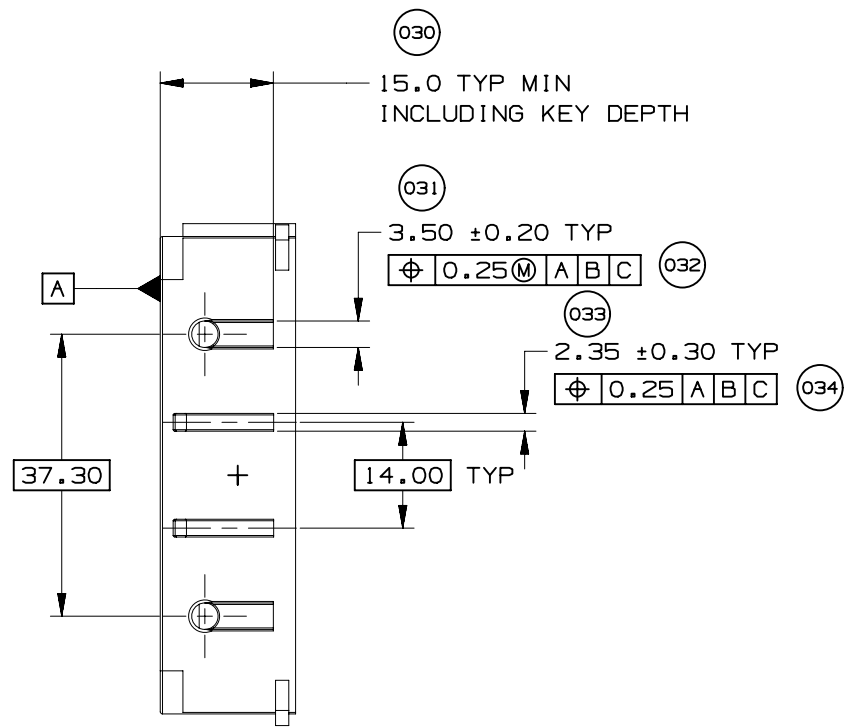
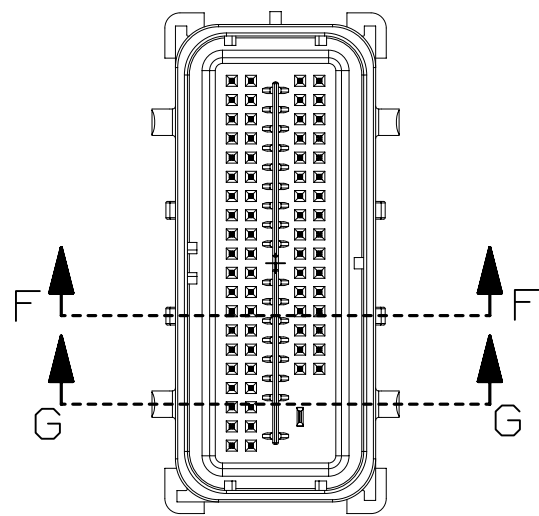

PAGE TITLE  
COMPONENT CONNECTOR INTERFACE

DRAWING NUMBER  
12672833

DWG STATUS			PAGE NUMBER
ST	REV	PDI	
R	001		16 OF 22

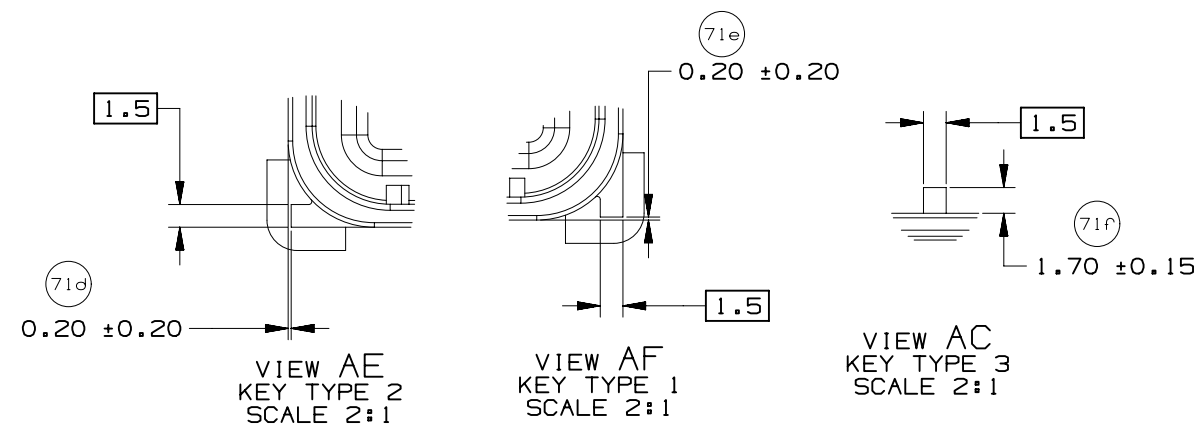
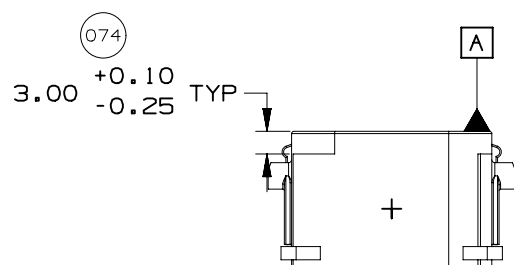
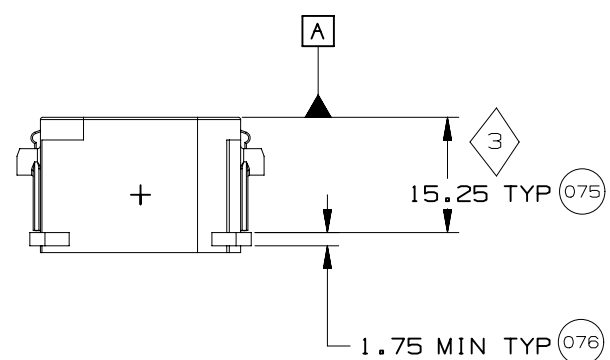
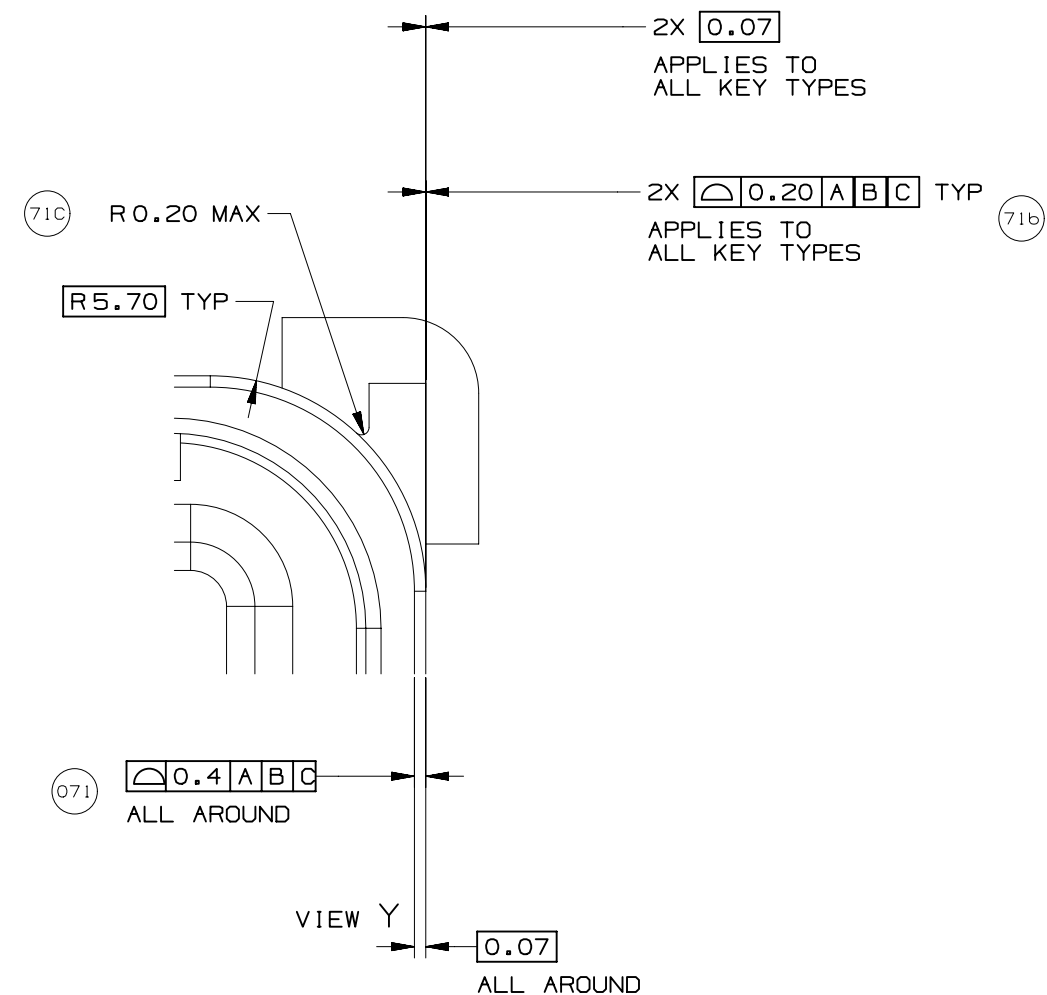
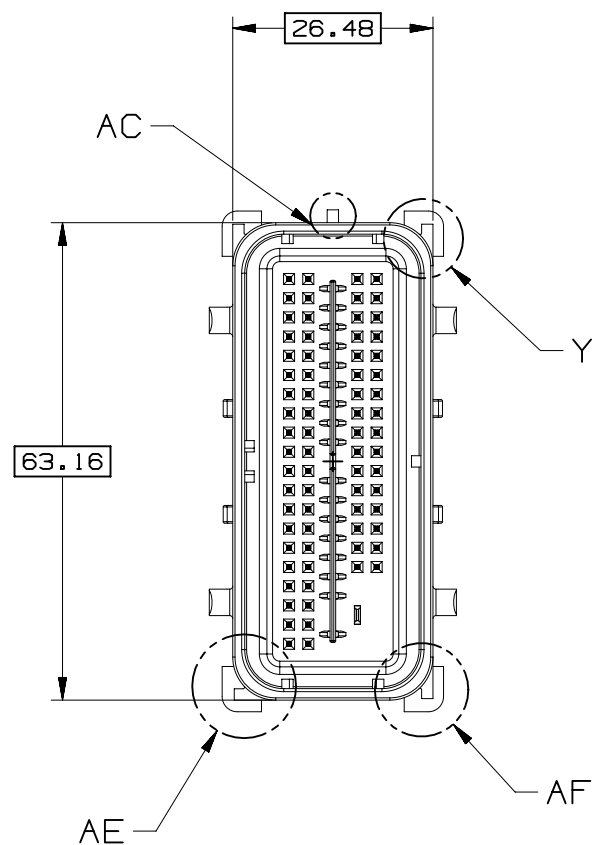
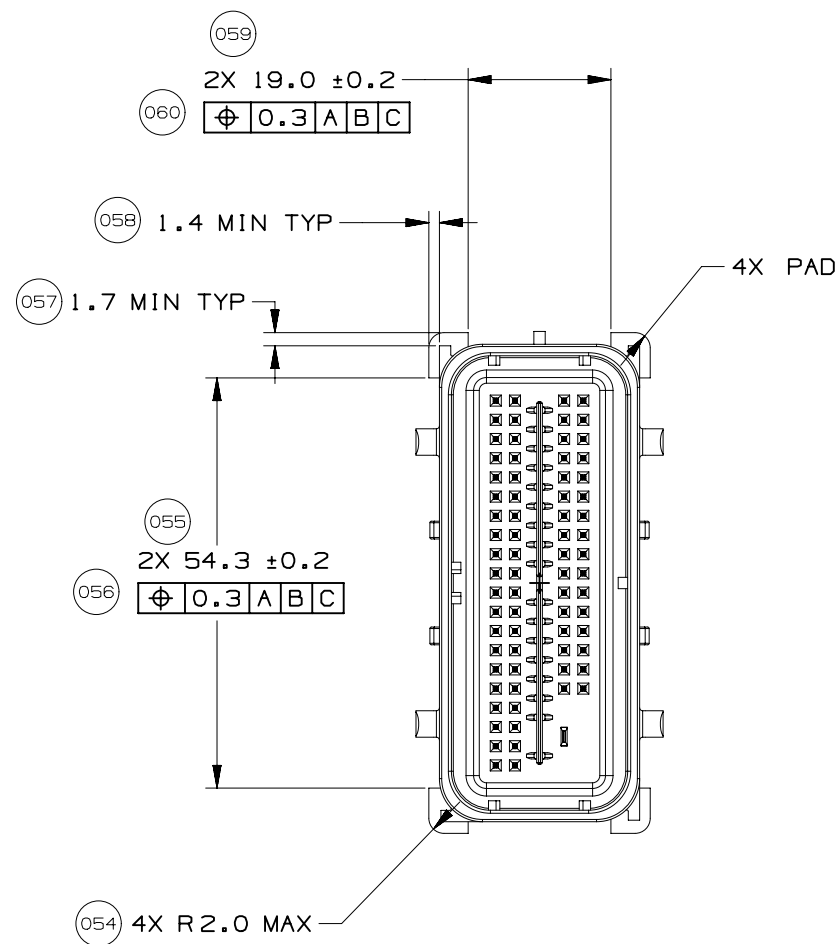

PAGE TITLE  
 COMPONENT CONNECTOR INTERFACE

DRAWING NUMBER  
 12672833

DWG STATUS			PAGE NUMBER
ST	REV	PD1	
R	001		17 OF 22

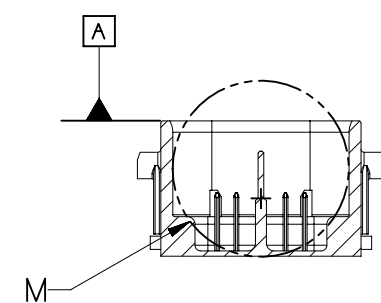
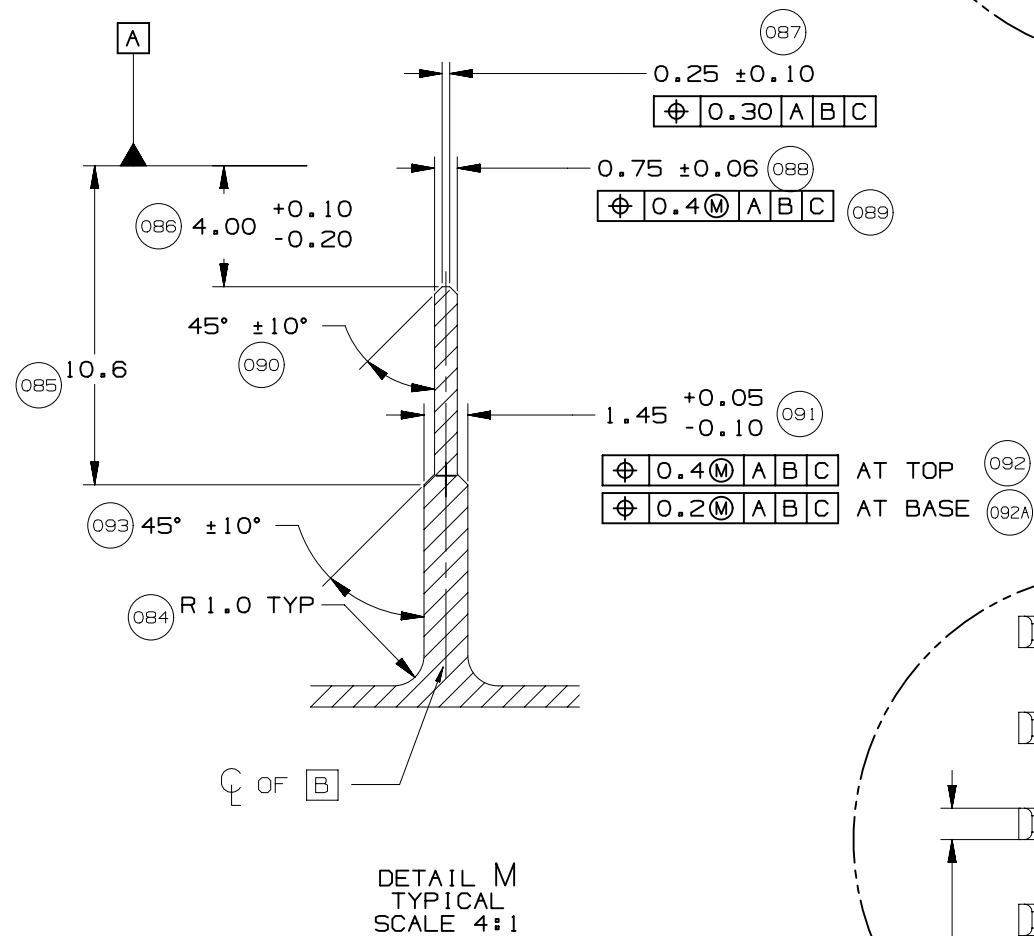
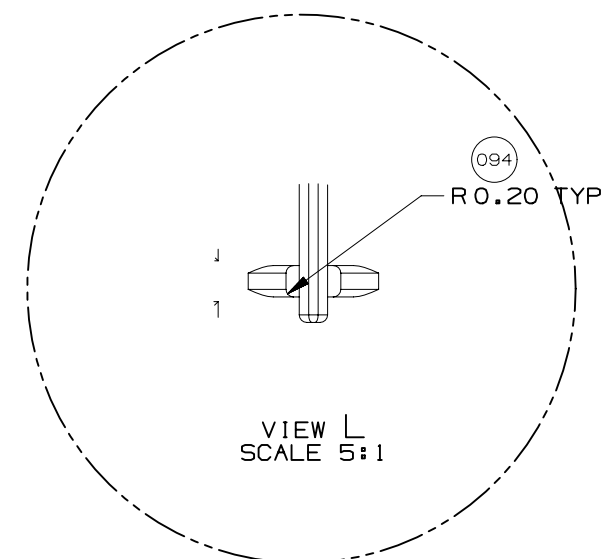
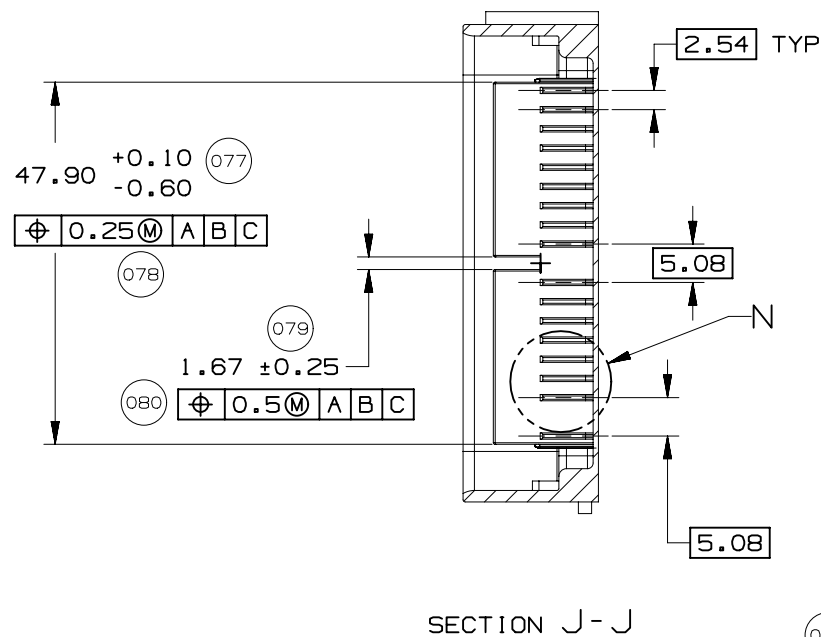
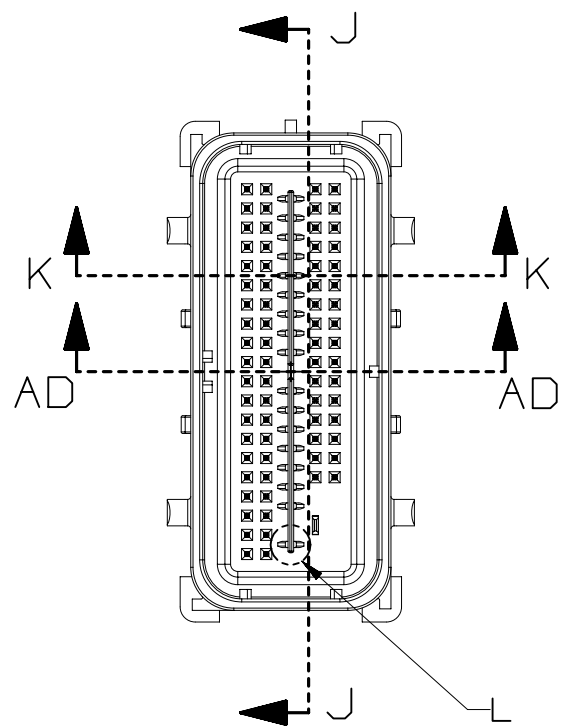

SECTION K-K

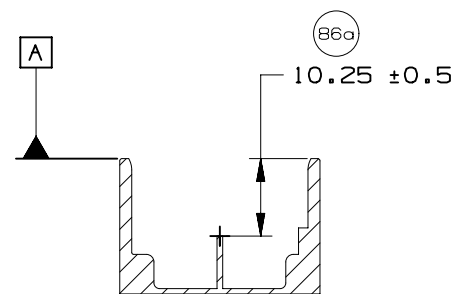

SECTION AD-AD

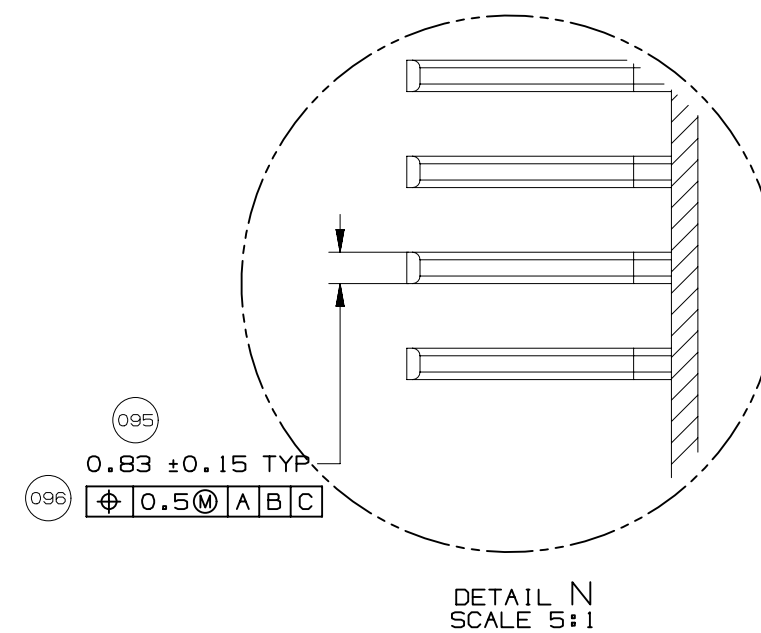

DETAIL N  
SCALE 5:1



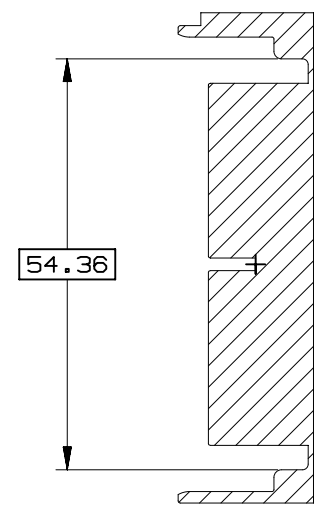
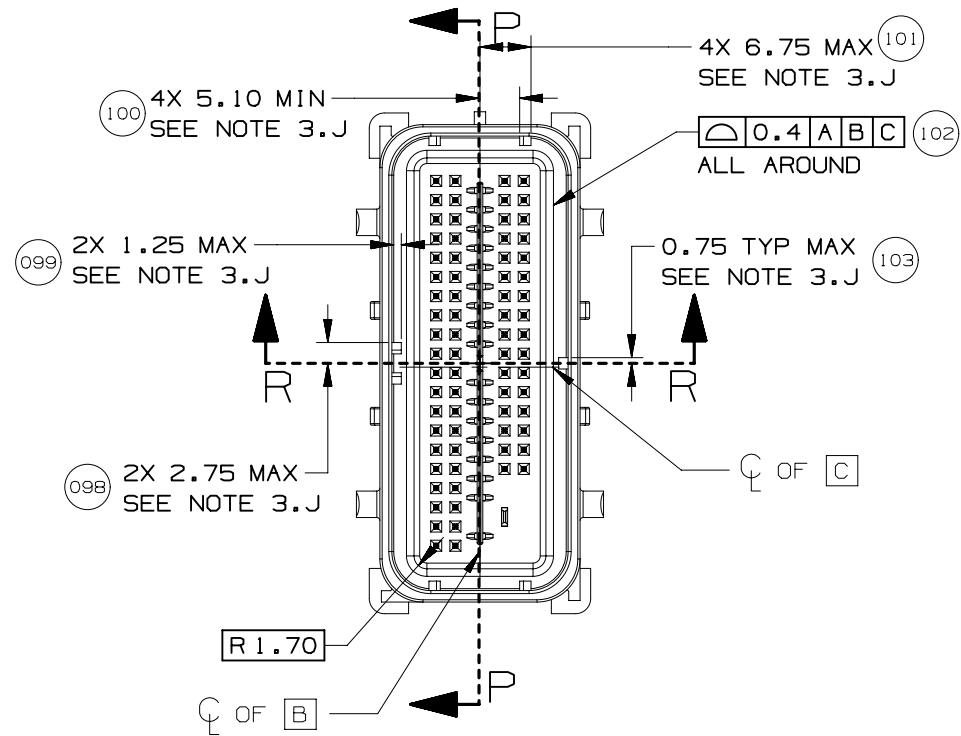

SECTION P-P

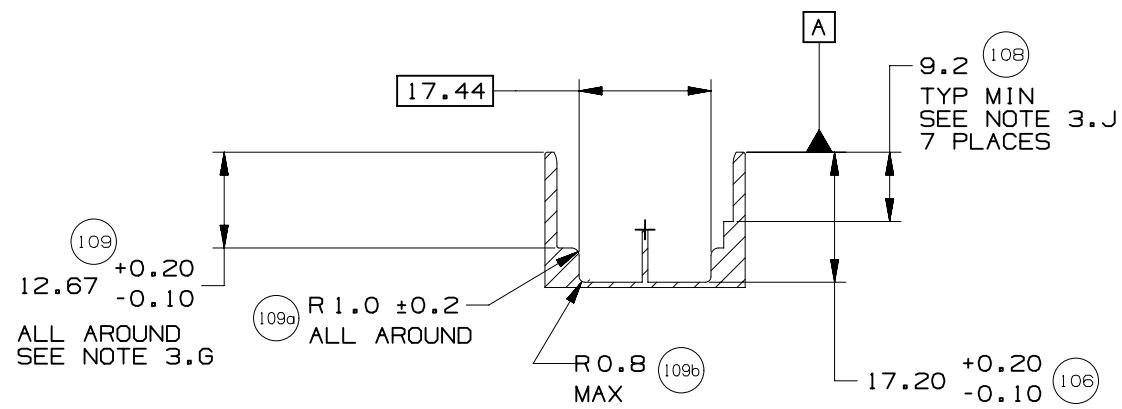

SECTION R-R



PAGE TITLE  
COMPONENT CONNECTOR INTERFACE

DRAWING NUMBER  
12672833

DWG STATUS			PAGE NUMBER	
ST	REV	PD1	19	OF 22
R	001			

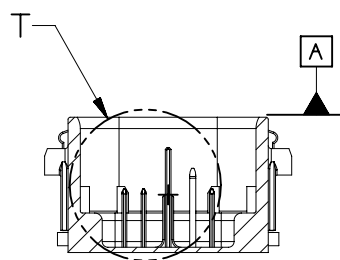
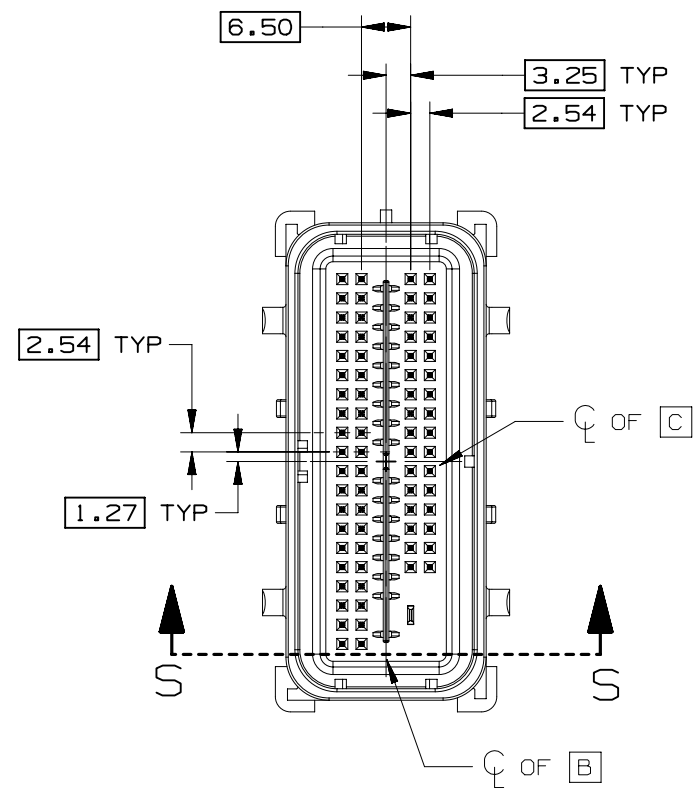

SECTION S-S

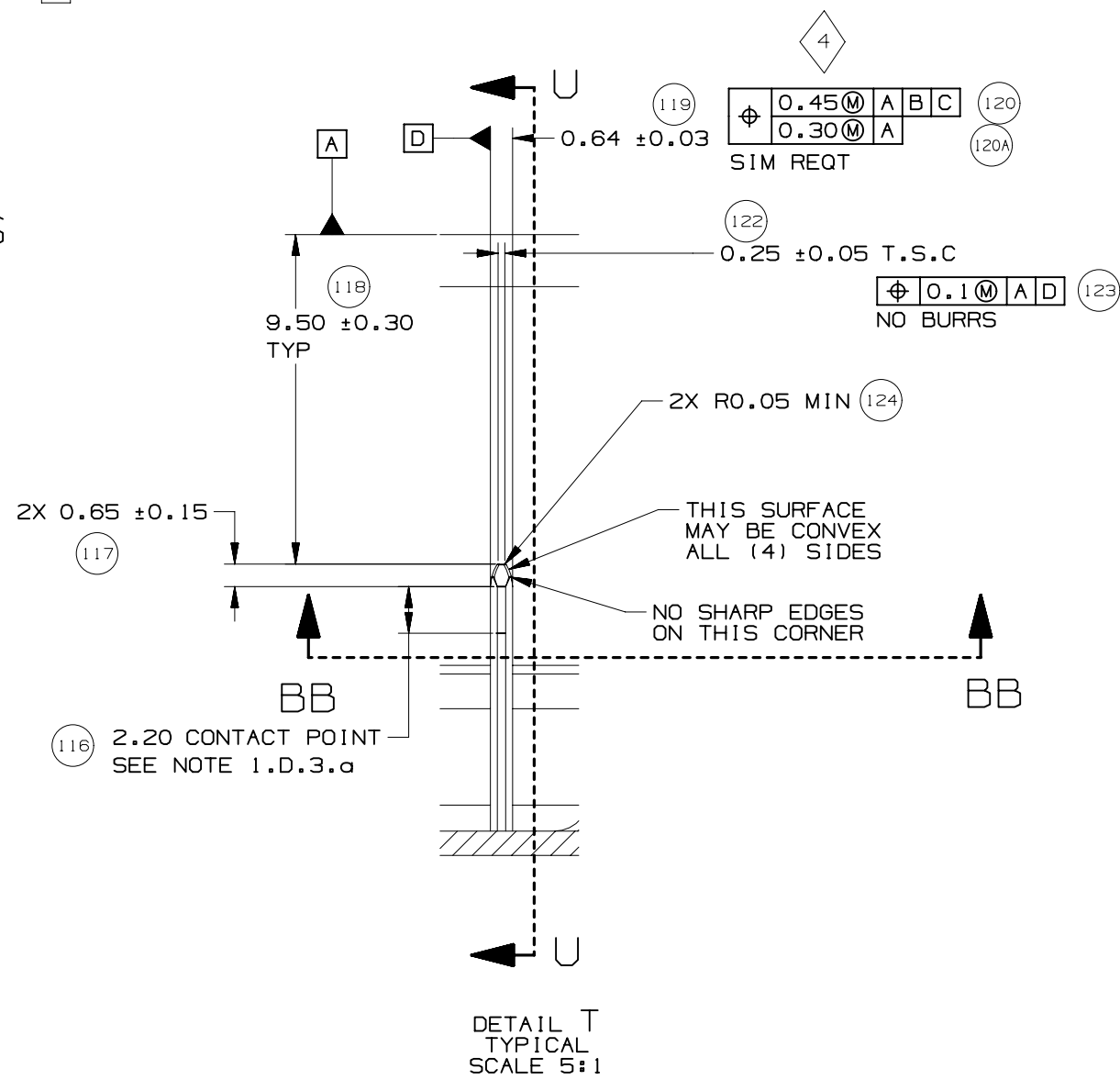

DETAIL T  
TYPICAL  
SCALE 5:1

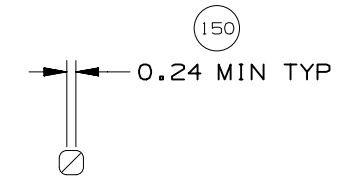

SECTION BB-BB

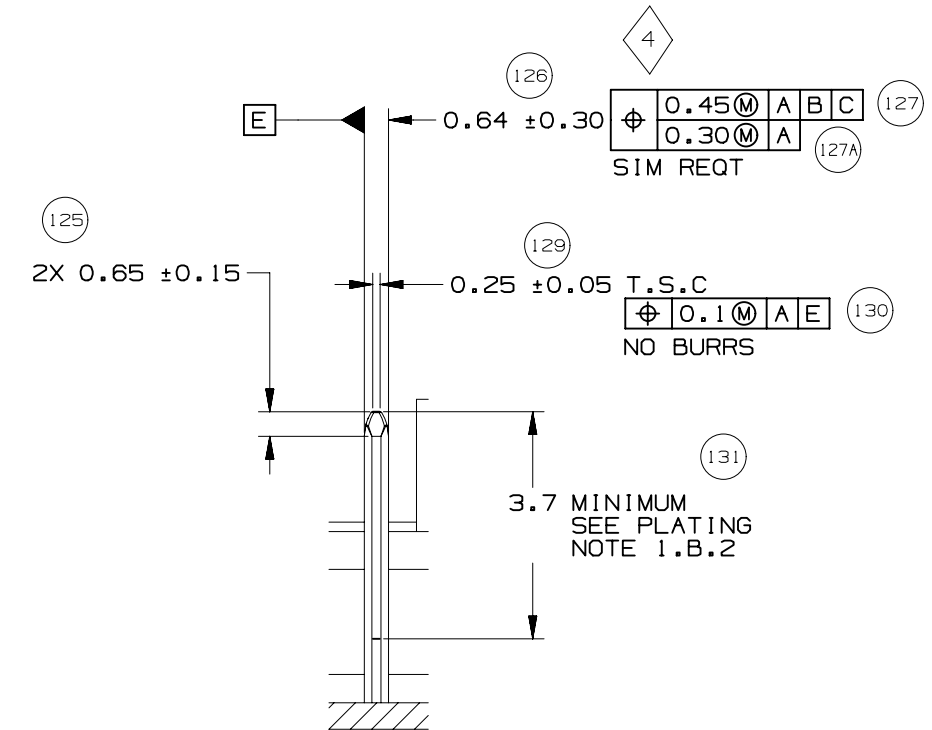

SECTION U-U  
TYPICAL





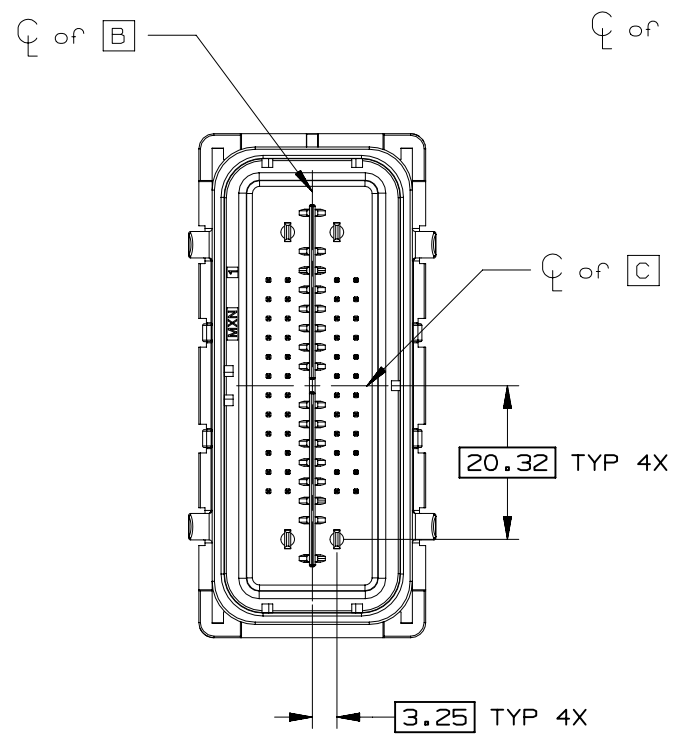

52 CKT COMPONENT  
CONNECTOR INTERFACE

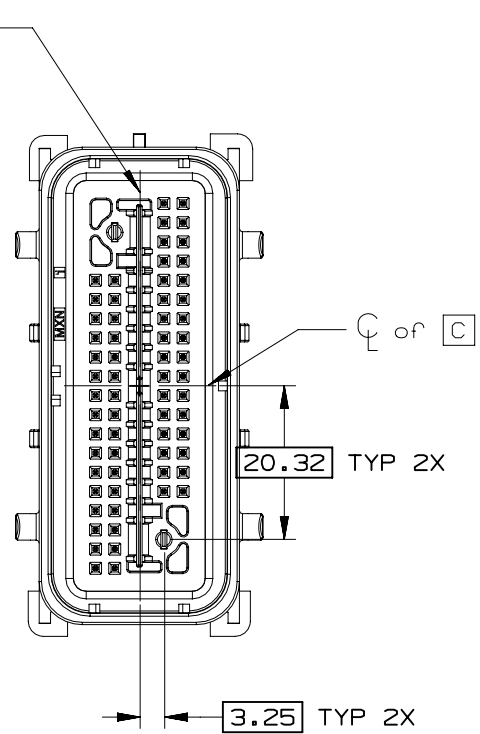

66 CKT COMPONENT  
CONNECTOR INTERFACE

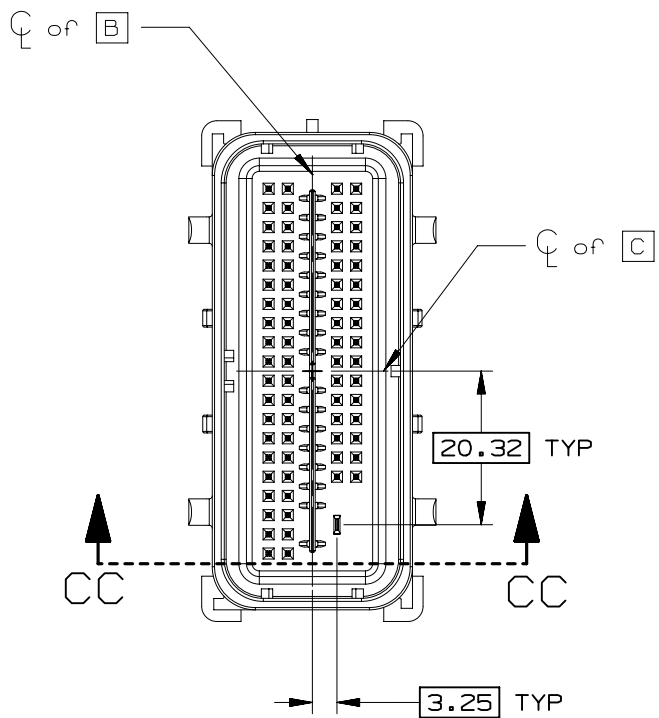

73 CKT COMPONENT  
CONNECTOR INTERFACE

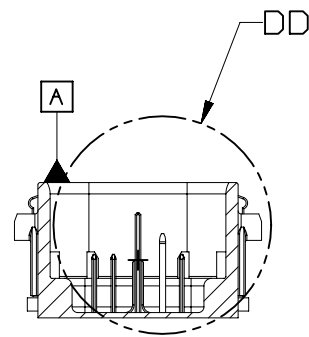

SECTION CC-CC

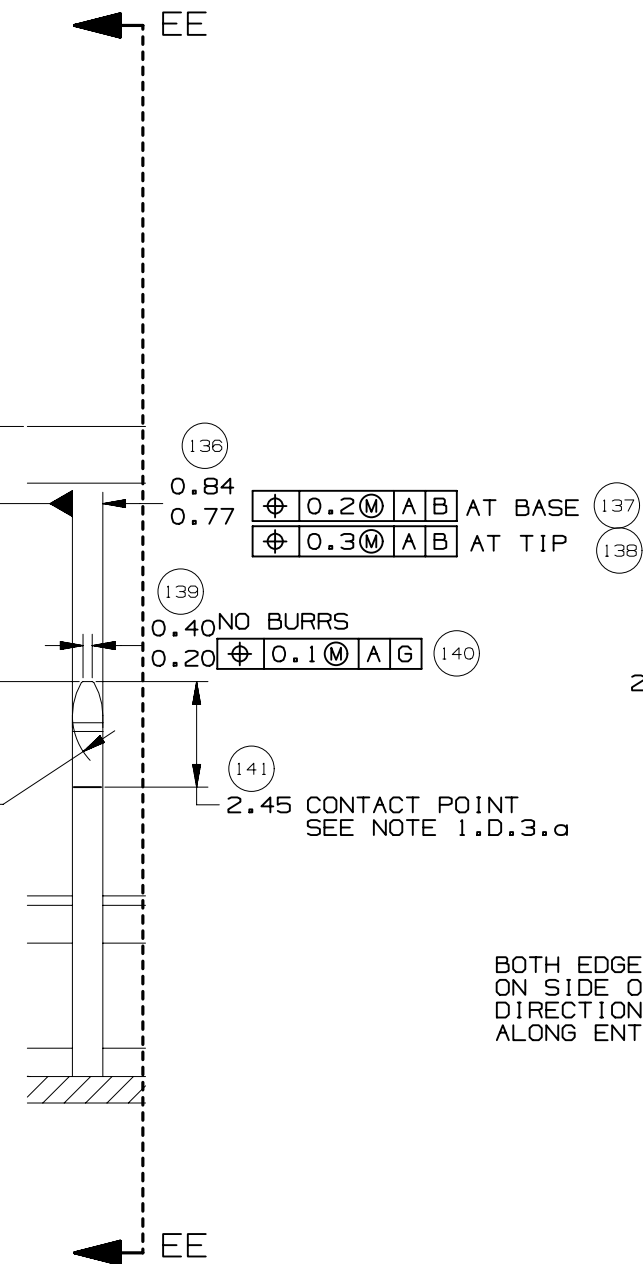

DETAIL DD  
TYPICAL  
SCALE 5:1

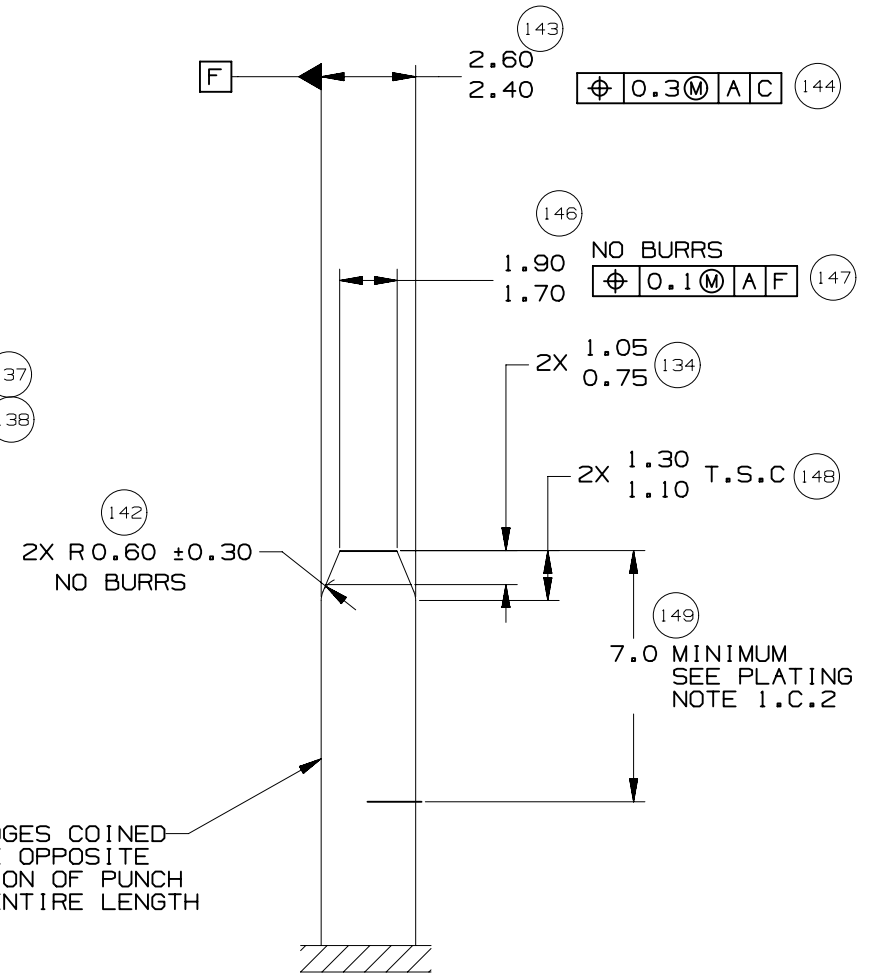

SECTION EE-EE  
TYPICAL



MOLEX MX64 RECEPTACLE TERMINAL INFORMATION

ITEM	MOLEX P/N	GM P/N	WIRE SIZE MM2	TYPE	PLATING	REEL WIND DIRECTION	COMMENTS
1	34736-0025		0.35	ISO	SILVER	LEFT	
2	34736-0026	12672850	0.35	ISO	SILVER	RIGHT	
3	34736-0027		0.5 / 0.75	ISO	SILVER	LEFT	
4	34736-0028	12672851	0.5 / 0.75	ISO	SILVER	RIGHT	

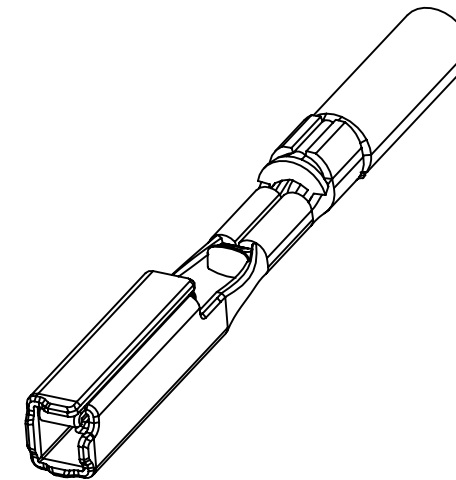
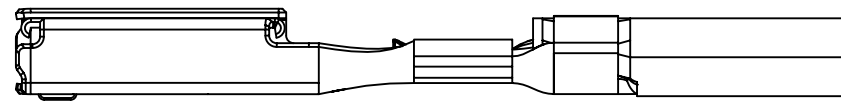
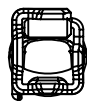

CAVITY PLUGS

ITEM	MFG	MFG P/N	GM P/N RD	SIZE	COLOR	MFG DRAWING	PROD SPEC	APP SPEC	COMMENTS
1	MOLEX	34586-0001	12674820	0.64	NATURAL	SD-34586-001	PS-34566-0000	AS-34566-001	
2	YAZAKI	7158-3114-90	12674821	2.8	BLUE	7158-3114-90	YPES-11-04-062	YPES-15-299	

ITEM 1

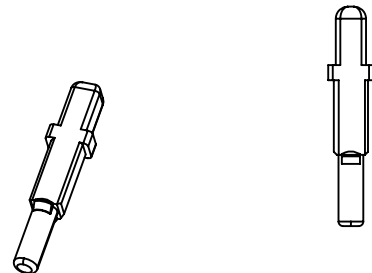

ITEM 2



PAGE TITLE  
ADDITIONAL COMPONENTS REQUIRED

DRAWING NUMBER  
12672833

DWG STATUS		
ST	REV	PD1
R	001	

PAGE NUMBER  
22 OF 22



E

D

C

B

A

CIRCUIT 61

CIRCUIT 41

CIRCUIT 21

CIRCUIT 1

+

+

+

KEY G

KEY H

RELEASE STATUS

RELEASE DATE

19

18

17

16

15

14

13

12

11

FORMAT: master-ib-prod-D  
REVISION: G  
DATE: 2015/12/14

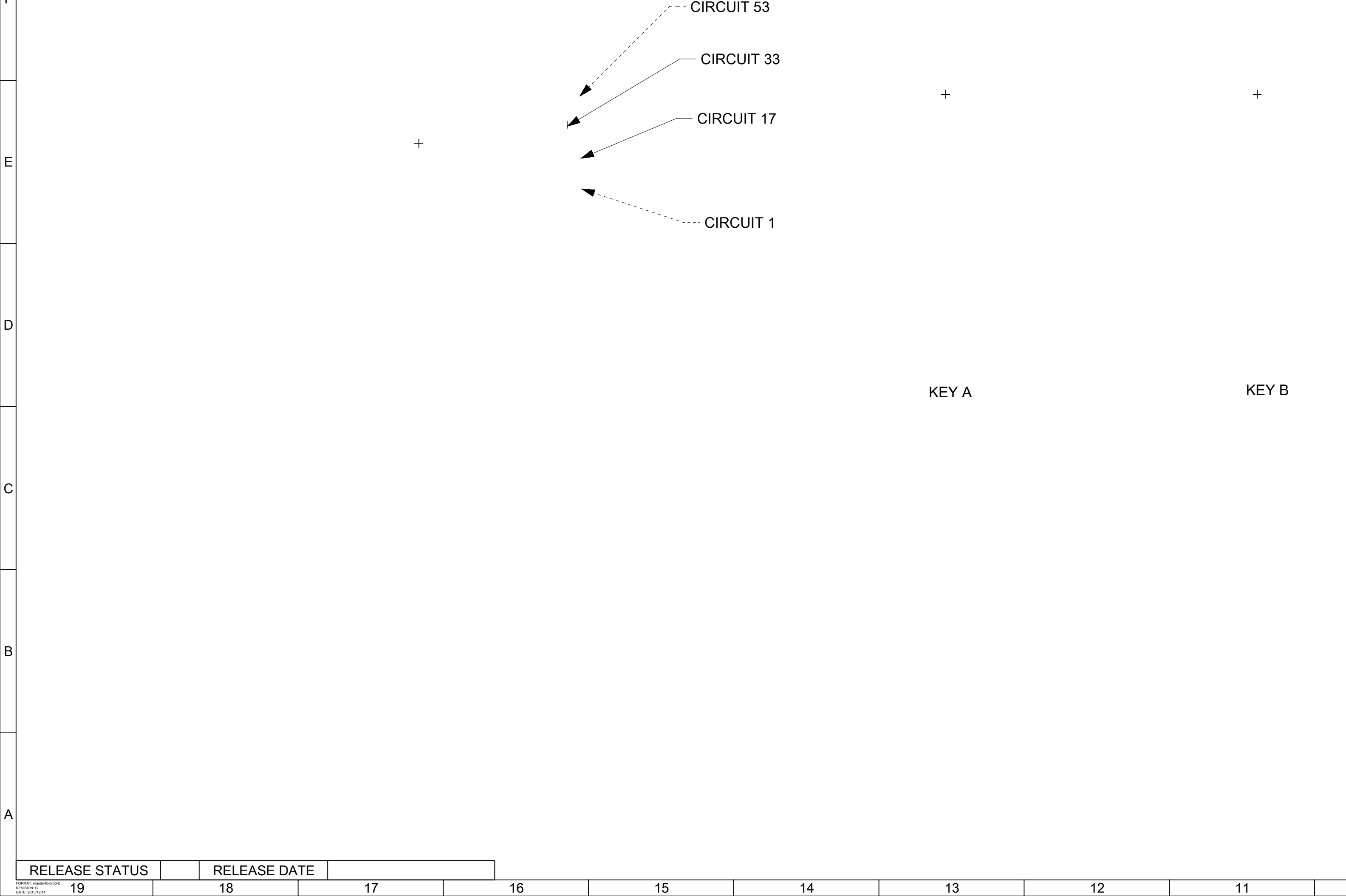

E

+

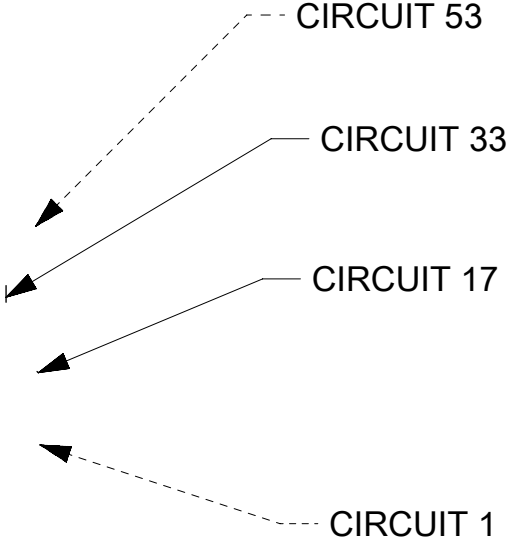

+

+

D

KEY A

KEY B

C

B

A

RELEASE STATUS	RELEASE DATE								
19	18	17	16	15	14	13	12	11	

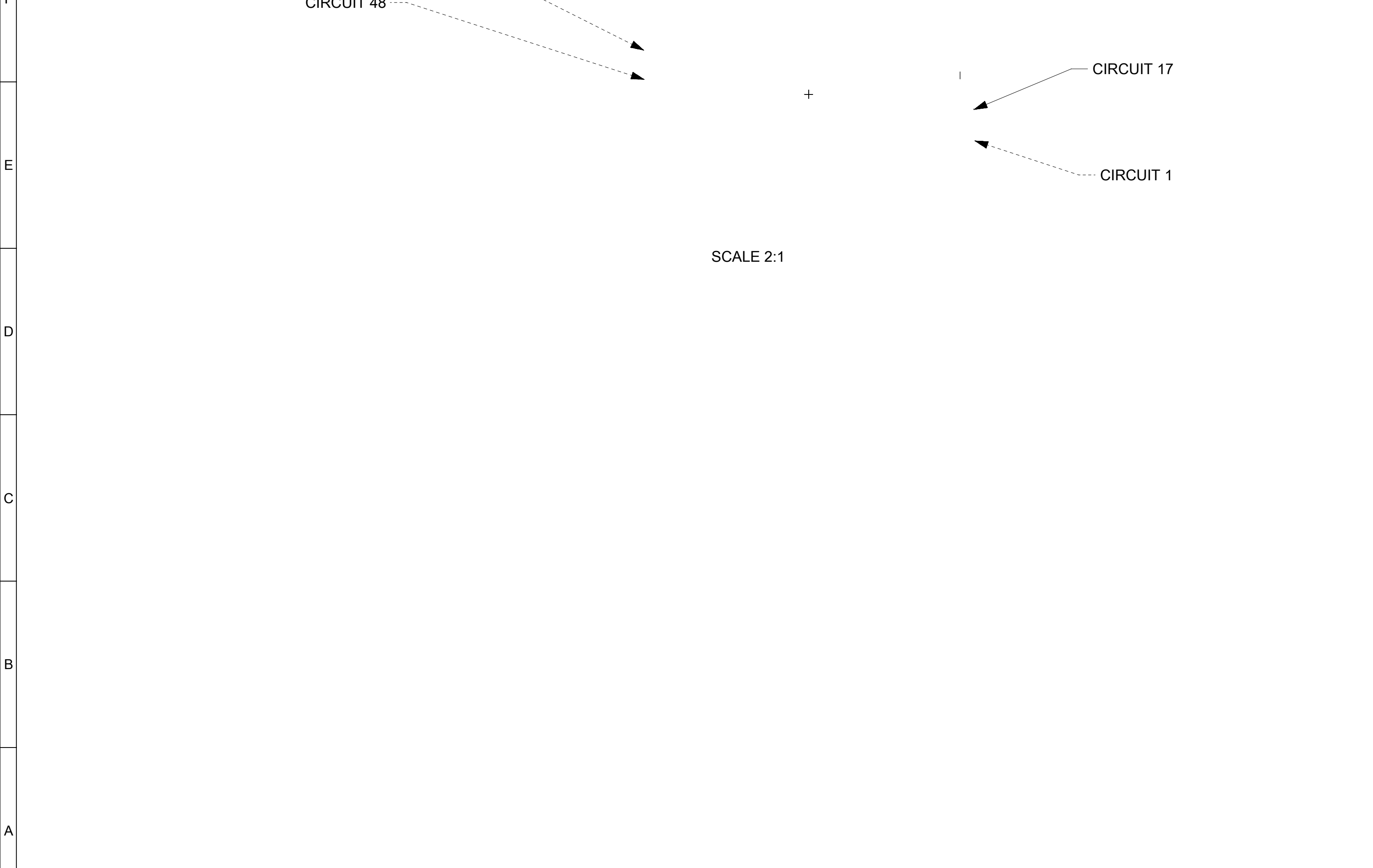

E

D

C

B

A

RELEASE STATUS	RELEASE DATE

19	18	17	16	15	14	13	12	11
----	----	----	----	----	----	----	----	----

FORMAT: master-lb-prod-D  
REVISION: 0  
DATE: 2015/12/14



RUBBER BAND  
 DESCRIPTION: #84 3.5" X 0.5"  
 SUGGESTED SOURCE:  
 MANUFACTURER: ALLIANCE  
 PART #: 987-370  
 VENDOR: OFFICE DEPOT  
 VENDOR #: 109099



TY-RAP  
 DESCRIPTION: SIZE TY25 CABLE TIE  
 SUGGESTED SOURCE:  
 MANUFACTURER: THOMAS & BETTS  
 PART #: TY25M  
 VENDOR: CRESENT ELEC  
 VENDOR #: 104144

PRODUCTION PART # FOR HARNESS ASSEMBLY

XXXXX- SERIES NUMBER		
SERIES #	CKT SIZE	WIRE TYPE
34070	73/80/66	TXL
34330	73/80/66	TXL
34333	73/80/66	PTFE

# HRNS ASSY

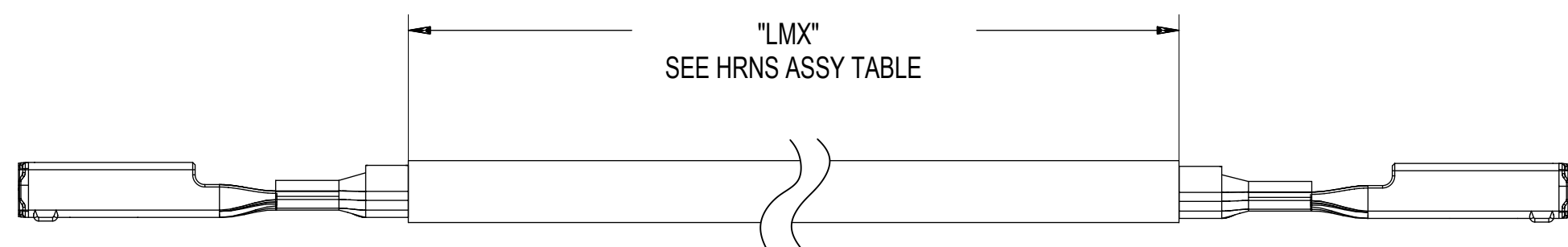

MX64 WIRE ASSY LOOPED  
 MATERIAL #: SEE HRNS ASSY TABLE

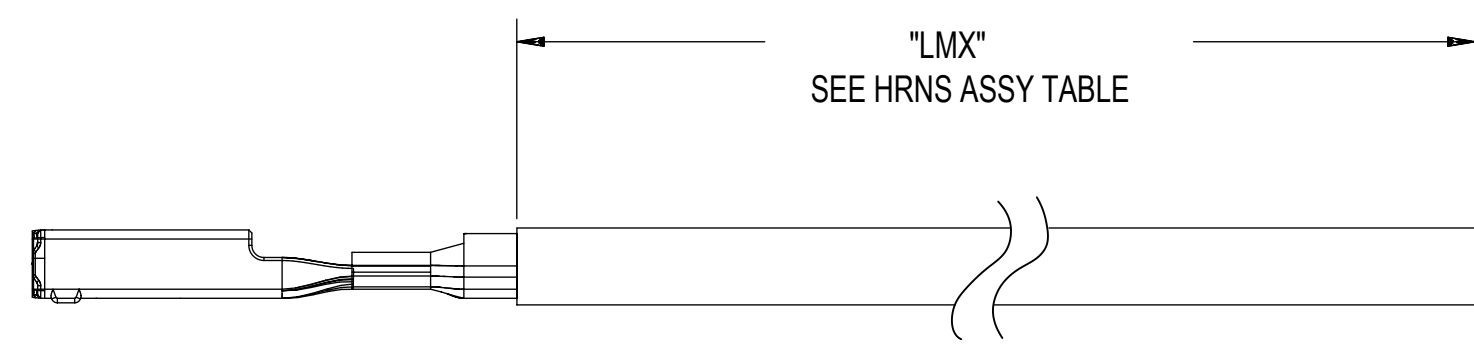

MX64 WIRE ASSY PIGTAIL  
 MATERIAL #: SEE HRNS ASSY TABLE

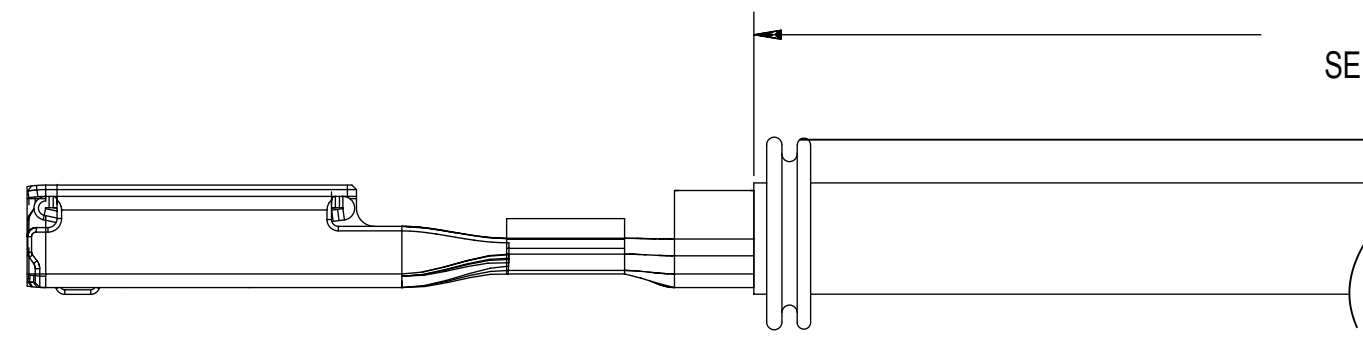

2.8mm YESC SEALED FEMALE  
 MATERIAL #: SEE HRNS ASSY TABLE

RELEASE STATUS	P1	RELEASE DATE	08.08.2017	01:37:07
----------------	----	--------------	------------	----------

E

D

C

B

A

H30

H30

NO	34070-9814	73	B	0	34566-0203
NO	34070-9234	80	H	0	34566-0803
NO	34070-9214	80	H	0	34566-0803
YES	34330-9914	73	A	0	34566-0103
YES	34330-9814	73	B	0	34566-0203
YES	34330-9214	80	H	0	34566-0803
NO	34070-9734	73	C	0	34566-0303
NO	34070-9714	73	C	0	34566-0303
NO	34330-9714	73	C	0	34566-0303
NO	34070-9334	80	G	0	34566-0703
NO	34070-9314	80	G	0	34566-0703
NO	34330-9314	80	G	0	34566-0703
NO	34070-9414	73	F	0	34566-0603
NO	34070-9434	73	F	0	34566-0603
NO	34333-9734	73	C	0	34566-0303

RELEASE STATUS	P1	RELEASE DATE	08.08.2017	01:37:07
----------------	----	--------------	------------	----------



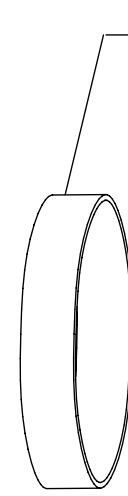

RUBBER BAND  
 DESCRIPTION: #84 3.5" X 0.5"  
 SUGGESTED SOURCE:  
 MANUFACTURER: ALLIANCE  
 PART #: 987-370  
 VENDOR: OFFICE DEPOT  
 VENDOR #: 109099



TY-RAP  
 DESCRIPTION: SIZE TY25 CABLE TIE  
 SUGGESTED SOURCE:  
 MANUFACTURER: THOMAS & BETTS  
 PART #: TY25M  
 VENDOR: CRESENT ELEC  
 VENDOR #: 104144

PRODUCTION PART # FOR HARNESS ASSEMBLY

XXXXXX- SERIES NUMBER		
SERIES #	CKT SIZE	WIRE TYPE
204778	80/73/66	ISO*
204779	80/73/66	ISO*

# HRNS ASSY



MX64 WIRE ASSY LOOPED  
 MATERIAL #: SEE HRNS ASSY TABLE

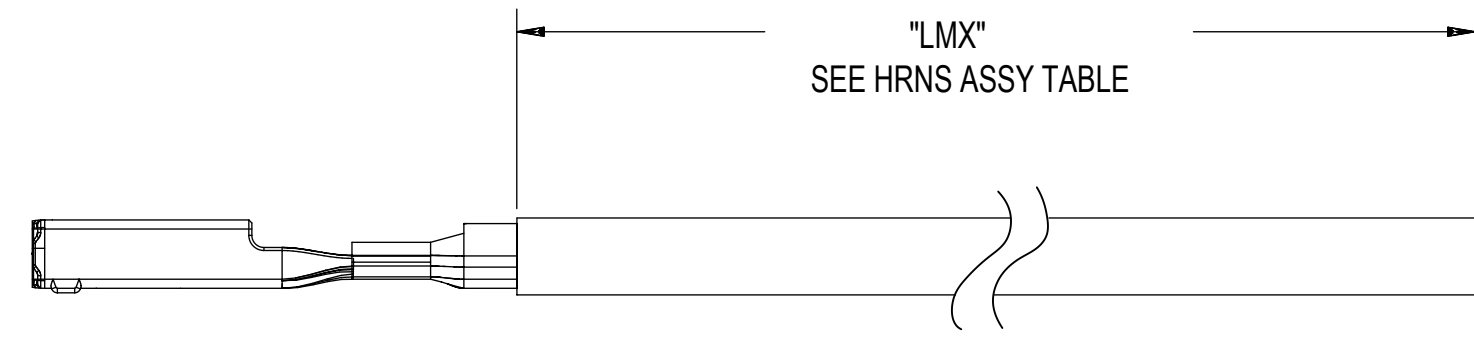

MX64 WIRE ASSY PIGTAIL  
 MATERIAL #: SEE HRNS ASSY TABLE

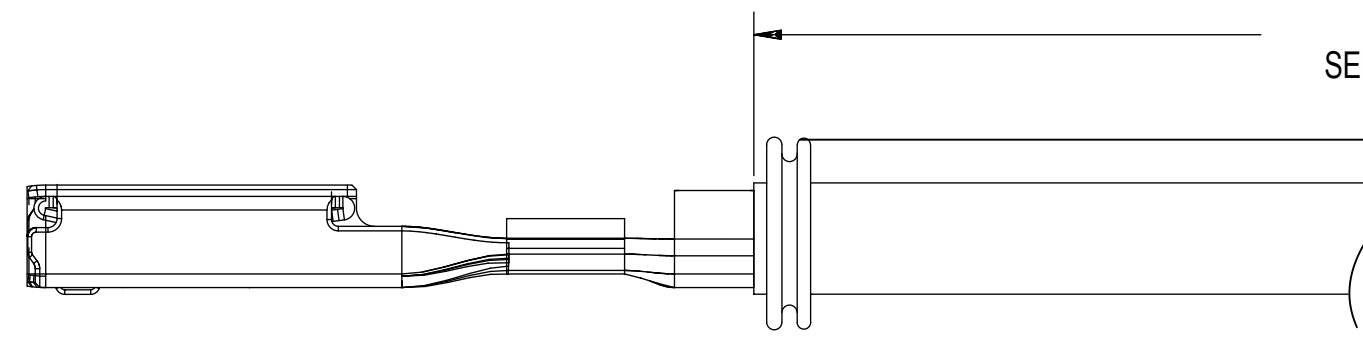

RELEASE STATUS	P1	RELEASE DATE	08.08.2017	01:37:07
----------------	----	--------------	------------	----------



E	(G41)	AVAILABLE	12672858	34822-0033	0	C	BLUE	65	52	51	16	15	
	(G41)	AVAILABLE	12672857	34822-0023	9	A	BLACK	64	63	62	61	60	59
	(G41)	AVAILABLE	12672859	34822-0043	9	C	BLUE	48	47	46	45	44	43
D		N/A	N/A	N/A	N/A	N/A	N/A	65				32	31
												16	15
C		AVAILABLE	NOT APPLICABLE	34566-2503	0	A	BLACK						
								72	71		69	68	67
										50		48	
								73				32	
SEE NEXT PAGE FOR ADDITIONAL NUMBERS													



E

D

C

B

A

AVAILABLE	NOT APPLICABLE	34566-4103	0	A	BLACK
AVAILABLE	NOT APPLICABLE	34566-4203	0	B	ST GRY
AVAILABLE	NOT APPLICABLE	34566-4303	0	A	BLACK

73							15
72	71		69	68	67	66	
52			49	48		46	
73				32			
						14	
		50	49	48		46	
73				32			
					15		
		70	69	68	67		
		50	49	48	47		
73				32	31	30	
				16			

SEE NEXT PAGE FOR ADDITIONAL NUMBERS

RELEASE STATUS		RELEASE DATE
----------------	--	--------------









E

AVAILABLE	NOT APPLICABLE	34566-7303	0	B	ST GRY
-----------	----------------	------------	---	---	--------

			69	68		66		
			49	48		46		44
73						29	28	
73							12	

D

AVAILABLE	NOT APPLICABLE	34566-7403	0	B	ST GRY
-----------	----------------	------------	---	---	--------

		50	49	48		46		
73						29		
73				15				

C

AVAILABLE	NOT APPLICABLE	34566-7503	0	A	BLACK
-----------	----------------	------------	---	---	-------

72	71	70	69	68	67	66		64
52	51	50	49	48	47	46		44
73				32	31	30	29	28
73				16	15	14	13	12

SEE NEXT PAGE FOR ADDITIONAL NUMBERS

B

A

RELEASE STATUS		RELEASE DATE	
----------------	--	--------------	--

E	AVAILABLE	NOT APPLICABLE	34566-8003	0	A	BLACK	<table border="1"> <tr> <td>32</td><td>31</td><td>30</td><td>29</td><td>28</td><td>27</td> </tr> <tr> <td>73</td><td>16</td><td></td><td></td><td>13</td><td>12</td><td>11</td> </tr> </table>	32	31	30	29	28	27	73	16			13	12	11																																				
	32	31	30	29	28	27																																																		
	73	16			13	12	11																																																	
	AVAILABLE	NOT APPLICABLE	34566-8103	0	H	ST GRY	<table border="1"> <tr> <td></td><td></td><td>78</td><td></td><td></td><td></td><td></td><td></td><td>72</td><td>71</td> </tr> <tr> <td>60</td><td>59</td><td>58</td><td>57</td><td>56</td><td></td><td></td><td></td><td>53</td><td>52</td> </tr> <tr> <td>40</td><td></td><td></td><td>37</td><td></td><td>35</td><td>34</td><td></td><td>33</td><td>32</td> </tr> <tr> <td>20</td><td>19</td><td>18</td><td>17</td><td>16</td><td></td><td></td><td></td><td>13</td><td>12</td> </tr> </table>			78						72	71	60	59	58	57	56				53	52	40			37		35	34		33	32	20	19	18	17	16				13	12									
		78						72	71																																															
60	59	58	57	56				53	52																																															
40			37		35	34		33	32																																															
20	19	18	17	16				13	12																																															
AVAILABLE	NOT APPLICABLE	34566-8203	0	A	BLACK	<table border="1"> <tr> <td></td><td></td><td>70</td><td></td><td></td><td>67</td><td>66</td><td></td><td></td><td></td> </tr> <tr> <td></td><td></td><td></td><td></td><td></td><td>47</td><td></td><td></td><td>44</td><td>43</td> </tr> <tr> <td colspan="5">73</td> <td></td><td>31</td><td>30</td><td></td><td>27</td> </tr> <tr> <td></td><td></td><td></td><td></td><td></td><td></td><td></td><td></td><td>13</td><td></td> </tr> </table>			70			67	66									47			44	43	73						31	30		27									13											
		70			67	66																																																		
					47			44	43																																															
73						31	30		27																																															
								13																																																
AVAILABLE	NOT APPLICABLE	34566-8303	0	A	BLACK	<table border="1"> <tr> <td>72</td><td>71</td><td></td><td>69</td><td>68</td><td>67</td><td>66</td><td></td><td>64</td><td>63</td> </tr> <tr> <td>52</td><td>51</td><td>50</td><td>49</td><td>48</td><td>47</td><td>46</td><td></td><td>44</td><td>43</td> </tr> <tr> <td colspan="5">73</td> <td>32</td><td>31</td><td>30</td><td>29</td><td>27</td> </tr> <tr> <td></td><td></td><td></td><td></td><td></td><td></td><td>15</td><td>14</td><td>13</td><td>12</td><td>11</td> </tr> </table>	72	71		69	68	67	66		64	63	52	51	50	49	48	47	46		44	43	73					32	31	30	29	27							15	14	13	12	11									
72	71		69	68	67	66		64	63																																															
52	51	50	49	48	47	46		44	43																																															
73					32	31	30	29	27																																															
						15	14	13	12	11																																														
SEE NEXT PAGE FOR ADDITIONAL NUMBERS																																																								
D																																																								
C																																																								
B																																																								
A																																																								
<table border="1"> <tr> <td>RELEASE STATUS</td> <td></td> <td>RELEASE DATE</td> <td></td> <td></td> <td></td> <td></td> </tr> <tr> <td>19</td> <td></td> <td>18</td> <td></td> <td>17</td> <td></td> <td>16</td> </tr> <tr> <td></td> <td></td> <td></td> <td></td> <td></td> <td></td> <td>15</td> </tr> <tr> <td></td> <td></td> <td></td> <td></td> <td></td> <td></td> <td>14</td> </tr> <tr> <td></td> <td></td> <td></td> <td></td> <td></td> <td></td> <td>13</td> </tr> <tr> <td></td> <td></td> <td></td> <td></td> <td></td> <td></td> <td>12</td> </tr> <tr> <td></td> <td></td> <td></td> <td></td> <td></td> <td></td> <td>11</td> </tr> </table>							RELEASE STATUS		RELEASE DATE					19		18		17		16							15							14							13							12							11	
RELEASE STATUS		RELEASE DATE																																																						
19		18		17		16																																																		
						15																																																		
						14																																																		
						13																																																		
						12																																																		
						11																																																		

E

AVAILABLE	NOT APPLICABLE	34566-8903	0	H	ST GRY

		78					
		58	57	56			53 52
40			37		35	34	33 32
20	19	18	17	16		14	12

D

AVAILABLE	NOT APPLICABLE	34566-9003	0	B	ST GRY
-----------	----------------	------------	---	---	--------

			69	68		66	
			49	48		46	44
73							29 28

C

AVAILABLE	NOT APPLICABLE	34566-9103	0	A	BLACK
-----------	----------------	------------	---	---	-------

				68			65
52	51	50			47		
73				32	31	30	29 28
				16	15	14	13 12

SEE NEXT PAGE FOR ADDITIONAL NUMBERS

B

A

RELEASE STATUS		RELEASE DATE
----------------	--	--------------

E

AVAILABLE	NOT APPLICABLE	34566-9703	0	A	BLACK

72	71	70	69	68
52	51	50	49	
73				32
				16

D

AVAILABLE	NOT APPLICABLE	34566-9803	0	A	BLACK
-----------	----------------	------------	---	---	-------

72	71	70	69	68
52	51	50	49	
73				32
				16

C

AVAILABLE	NOT APPLICABLE	34566-9903	0	A	BLACK
-----------	----------------	------------	---	---	-------

	71		69	68
52		50	49	
73				32
				16

SEE NEXT PAGE FOR ADDITIONAL NUMBERS

B

A

RELEASE STATUS		RELEASE DATE
----------------	--	--------------

FORMAT: master-lb-prod-D  
 REVISION: 0  
 DATE: 2015/12/14

E

AVAILABLE	NOT APPLICABLE	34566-1063	0	B	ST GRY

40	39	38	37	36	35	34	33	32	31	30
20	19	18	17	16		14	13	12	11	
							65			
			49	48	47			44		
73							29	28		

D

AVAILABLE	NOT APPLICABLE	34566-1073	0	A	BLACK
-----------	----------------	------------	---	---	-------

72	71	70	69	68	67	66	65	64	63	
		50	49	48	47					42
73				32	31	30	29	28	27	26
				16			13	12	11	10

C

AVAILABLE	NOT APPLICABLE	34566-1083	0	B	ST GRY
-----------	----------------	------------	---	---	--------

				68	67	66	65	64		
	51	50	49	48		46	45		43	42
73				32	31	30				26
				16			13			10

SEE NEXT PAGE FOR ADDITIONAL NUMBERS

B

A

RELEASE STATUS		RELEASE DATE	
----------------	--	--------------	--

FORMAT: master-ib-prod-D  
 REVISION: 10  
 DATE: 2015/12/14

E

D

C

B

A

	APPLICABLE				
AVAILABLE	NOT APPLICABLE	34566-1163	0	H	ST GRY
AVAILABLE	NOT APPLICABLE	34566-1173	0	A	BLACK
AVAILABLE	NOT APPLICABLE	34566-1183	0	B	ST GRY

		73				
--	--	----	--	--	--	--

		78			
60	59	58	57	56	
40			37		35
20	19	18	17	16	

72	71		69	68	
52		50	49	48	47
73				32	31
				16	

			49	48	47
73					

RELEASE STATUS		RELEASE DATE
----------------	--	--------------

E

AVAILABLE	NOT APPLICABLE	34566-1253	9	B	ST GRY
-----------	----------------	------------	---	---	--------

								65			
			49	48		46					
73											

D

AVAILABLE	NOT APPLICABLE	34566-1263	9	A	BLACK
-----------	----------------	------------	---	---	-------

NUMBERS IN BOLD MUST USE SAE WIRE SIZE (NO.20) OR (NO.18 MAX. O.D. DRAWING NUMBER)

<b>72</b>	<b>71</b>		69	68	67	66		64	63	62
		50		48		46		44	43	42
73				32		30	29		27	
						14	13	12	11	

C

AVAILABLE	NOT APPLICABLE	34566-1273	0	A	BLACK
-----------	----------------	------------	---	---	-------

		70	69	68			65	64	63	
52		50	49	48	47					
73				32	31	30	29	28	27	
				16			13	12	11	10

B

A

RELEASE STATUS		RELEASE DATE	
----------------	--	--------------	--

E	AVAILABLE	NOT APPLICABLE	34566-1333	0	A	BLACK	<table border="1"> <tr> <td>52</td> <td></td> <td>70</td> <td>69</td> <td>68</td> <td></td> <td>47</td> <td></td> <td>65</td> <td>64</td> <td></td> </tr> <tr> <td colspan="4">73</td> <td>32</td> <td>31</td> <td>30</td> <td>29</td> <td>28</td> <td>27</td> </tr> <tr> <td colspan="4"></td> <td>16</td> <td></td> <td></td> <td>13</td> <td>12</td> <td>11</td> </tr> </table>	52		70	69	68		47		65	64		73				32	31	30	29	28	27					16			13	12	11									
	52		70	69	68		47		65	64																																					
	73				32	31	30	29	28	27																																					
					16			13	12	11																																					
AVAILABLE	NOT APPLICABLE	34566-1343	0	A	BLACK	<table border="1"> <tr> <td>72</td> <td>71</td> <td></td> <td>69</td> <td></td> <td>67</td> <td></td> <td>65</td> <td>64</td> <td>63</td> </tr> <tr> <td></td> <td></td> <td>50</td> <td>49</td> <td>48</td> <td>47</td> <td></td> <td></td> <td></td> <td></td> </tr> <tr> <td colspan="4">73</td> <td>32</td> <td>31</td> <td>30</td> <td>29</td> <td>28</td> <td>27</td> </tr> <tr> <td colspan="4"></td> <td>16</td> <td></td> <td></td> <td>13</td> <td>12</td> <td>11</td> </tr> </table>	72	71		69		67		65	64	63			50	49	48	47					73				32	31	30	29	28	27					16			13	12	11	
72	71		69		67		65	64	63																																						
		50	49	48	47																																										
73				32	31	30	29	28	27																																						
				16			13	12	11																																						
D	AVAILABLE	NOT APPLICABLE	34566-1353	0	H	ST GRY	<table border="1"> <tr> <td></td> <td>79</td> <td>78</td> <td>77</td> <td>76</td> <td>75</td> <td>74</td> <td>73</td> <td>72</td> <td>71</td> </tr> <tr> <td>60</td> <td>59</td> <td>58</td> <td>57</td> <td>56</td> <td></td> <td></td> <td>53</td> <td></td> <td></td> </tr> <tr> <td>40</td> <td>39</td> <td>38</td> <td>37</td> <td></td> <td>35</td> <td>34</td> <td></td> <td>32</td> <td></td> </tr> <tr> <td>20</td> <td>19</td> <td>18</td> <td>17</td> <td></td> <td></td> <td></td> <td>13</td> <td>12</td> <td>11</td> </tr> </table>		79	78	77	76	75	74	73	72	71	60	59	58	57	56			53			40	39	38	37		35	34		32		20	19	18	17				13	12	11
		79	78	77	76	75	74	73	72	71																																					
	60	59	58	57	56			53																																							
	40	39	38	37		35	34		32																																						
20	19	18	17				13	12	11																																						
C	AVAILABLE	NOT APPLICABLE	34566-1363	0	A	BLACK	<table border="1"> <tr> <td>72</td> <td>71</td> <td></td> <td>69</td> <td>68</td> <td>67</td> <td>66</td> <td></td> <td>64</td> <td>63</td> </tr> <tr> <td></td> <td></td> <td></td> <td></td> <td>48</td> <td></td> <td>46</td> <td></td> <td>44</td> <td>43</td> </tr> <tr> <td colspan="4">73</td> <td>32</td> <td></td> <td></td> <td>29</td> <td></td> <td>27</td> </tr> <tr> <td colspan="4"></td> <td></td> <td></td> <td>14</td> <td>13</td> <td>12</td> <td>11</td> </tr> </table>	72	71		69	68	67	66		64	63					48		46		44	43	73				32			29		27							14	13	12	11
	72	71		69	68	67	66		64	63																																					
					48		46		44	43																																					
	73				32			29		27																																					
						14	13	12	11																																						

B										
A										

RELEASE STATUS		RELEASE DATE								
19		18		17		16		15		14
										13
										12
										11



E

	APPLICABLE								73	32			29
AVAILABLE	NOT APPLICABLE	34566-1443	0	B	ST GRY								

			69	68		66	
			49	48		46	
73							29

D

						66	65
AVAILABLE	NOT APPLICABLE	34566-1453	0	B	ST GRY		

			49	48	47		
73							29

C

			69	68			65
AVAILABLE	NOT APPLICABLE	34566-1463	0	A	BLACK	52	45

73			32	31	30	29
73			16			13

B

A

RELEASE STATUS		RELEASE DATE	
----------------	--	--------------	--



E	AVAILABLE	NOT APPLICABLE	34566-1653	0	B	ST GRY	<table border="1"> <tr><td></td><td></td><td></td><td></td><td></td><td></td><td>66</td><td></td><td></td><td></td><td></td><td></td></tr> <tr><td></td><td></td><td>50</td><td></td><td>48</td><td></td><td>46</td><td></td><td></td><td></td><td></td><td></td></tr> <tr><td colspan="2">73</td><td></td><td></td><td></td><td></td><td></td><td>29</td><td></td><td></td><td></td><td></td></tr> <tr><td></td><td></td><td></td><td></td><td>15</td><td></td><td></td><td></td><td>12</td><td></td><td></td><td></td></tr> </table>							66								50		48		46						73							29									15				12			
							66																																																
		50		48		46																																																	
73							29																																																
				15				12																																															
D	AVAILABLE	NOT APPLICABLE	34566-1663	0	B	ST GRY	<table border="1"> <tr><td></td><td></td><td></td><td></td><td></td><td></td><td>66</td><td></td><td></td><td></td><td></td><td></td></tr> <tr><td></td><td></td><td>50</td><td></td><td>48</td><td></td><td>46</td><td></td><td></td><td></td><td></td><td></td></tr> <tr><td colspan="2">73</td><td></td><td></td><td></td><td></td><td></td><td>29</td><td></td><td></td><td></td><td></td></tr> <tr><td></td><td></td><td></td><td></td><td>15</td><td></td><td></td><td></td><td></td><td></td><td></td><td></td></tr> </table>							66								50		48		46						73							29									15							
							66																																																
		50		48		46																																																	
73							29																																																
				15																																																			
C	AVAILABLE	NOT APPLICABLE	34566-1673	0	A	BLACK	<table border="1"> <tr><td>72</td><td>71</td><td>70</td><td>69</td><td>68</td><td>67</td><td>66</td><td>65</td><td>64</td><td>63</td><td>62</td><td></td></tr> <tr><td>52</td><td></td><td></td><td>49</td><td>48</td><td></td><td></td><td>45</td><td>44</td><td>43</td><td>42</td><td>41</td></tr> <tr><td colspan="2">73</td><td></td><td></td><td>32</td><td></td><td></td><td>29</td><td></td><td>27</td><td></td><td>25</td></tr> <tr><td></td><td></td><td></td><td></td><td>16</td><td></td><td></td><td>13</td><td>12</td><td>11</td><td></td><td>9</td></tr> </table>	72	71	70	69	68	67	66	65	64	63	62		52			49	48			45	44	43	42	41	73				32			29		27		25					16			13	12	11		9
	72	71	70	69	68	67	66	65	64	63	62																																												
	52			49	48			45	44	43	42	41																																											
73				32			29		27		25																																												
				16			13	12	11		9																																												
B	AVAILABLE	NOT APPLICABLE	34566-1683	0	B	ST GRY	<table border="1"> <tr><td></td><td></td><td></td><td></td><td></td><td>67</td><td>66</td><td></td><td></td><td>63</td><td></td><td></td></tr> <tr><td></td><td></td><td>50</td><td>49</td><td>48</td><td></td><td></td><td></td><td></td><td>43</td><td></td><td></td></tr> <tr><td colspan="2">73</td><td></td><td></td><td></td><td></td><td></td><td>29</td><td></td><td>27</td><td></td><td></td></tr> <tr><td></td><td></td><td></td><td></td><td>16</td><td>15</td><td>14</td><td>13</td><td></td><td></td><td></td><td></td></tr> </table>						67	66			63					50	49	48					43			73							29		27							16	15	14	13				
						67	66			63																																													
		50	49	48					43																																														
73							29		27																																														
				16	15	14	13																																																
A																																																							

RELEASE STATUS		RELEASE DATE
----------------	--	--------------

FORMAT: master-ib-prod-D  
 REVISION: 10  
 DATE: 2015/12/14

E

AVAILABLE	NOT APPLICABLE	34566-1743	0	A	BLACK
-----------	----------------	------------	---	---	-------

		70			67
			49		47
73				32	
				16	15

D

AVAILABLE	NOT APPLICABLE	34566-1753	0	A	BLACK
-----------	----------------	------------	---	---	-------

		70			67
			49		47
73				32	
					15

C

AVAILABLE	NOT APPLICABLE	34566-1763	0	B	ST GRY
-----------	----------------	------------	---	---	--------

					67
	51	50	49	48	47
73				32	31
				16	15

B

A

RELEASE STATUS		RELEASE DATE	
----------------	--	--------------	--

E

AVAILABLE	NOT APPLICABLE	34566-1833	0	A	BLACK
-----------	----------------	------------	---	---	-------

				68			65
52		50			47		
73				32	31	30	29
				16			13

D

AVAILABLE	NOT APPLICABLE	34566-1843	0	A	BLACK
-----------	----------------	------------	---	---	-------

				68			65
52		50			47		
73				32	31	30	29
				16	15	14	13

C

AVAILABLE	NOT APPLICABLE	34566-1853	0	A	BLACK
-----------	----------------	------------	---	---	-------

72		70	69	68	67		65
52		50	49	48	47		
73						30	29
				16	15		

B

AVAILABLE	NOT APPLICABLE	34566-1863	0	B	ST GRY
-----------	----------------	------------	---	---	--------

				68	67	66	65
						46	45
73				32		30	29
				16			

A

RELEASE STATUS		RELEASE DATE
----------------	--	--------------

E

AVAILABLE	NOT APPLICABLE	34566-1933	0	A	BLACK
-----------	----------------	------------	---	---	-------

		70			67	66	65					
			49		47			44	43	42	4	
73					32		30			27		2
					16	15		13			10	9

D

AVAILABLE	NOT APPLICABLE	34566-1943	0	A	BLACK
-----------	----------------	------------	---	---	-------

		70			67	66	65					
	51		49		47			44	43	42	4	
73					32		30			27		2
					16	15		13			10	9

C

AVAILABLE	NOT APPLICABLE	34566-1953	0	C	BLUE
-----------	----------------	------------	---	---	------

72		70				66			63			
52	51				48	47	46		44		42	
73							30				26	2
						15	14				10	9

B

AVAILABLE	NOT APPLICABLE	34566-1963	0	C	BLUE
-----------	----------------	------------	---	---	------

72		70				66			63			
52	51					46		44		42		
73							30				26	2
						15	14				10	9

A

RELEASE STATUS		RELEASE DATE	
----------------	--	--------------	--

E	AVAILABLE	NOT APPLICABLE	34566-2053	0	B	ST GRY	<table border="1"> <tr><td></td><td></td><td>70</td><td></td><td>68</td><td>67</td><td>66</td><td>65</td><td></td><td></td><td></td></tr> <tr><td></td><td></td><td></td><td>49</td><td></td><td>47</td><td></td><td></td><td>44</td><td>43</td><td>42</td></tr> <tr><td colspan="2"></td><td colspan="2">73</td><td></td><td>32</td><td></td><td>30</td><td></td><td></td><td>27</td></tr> <tr><td></td><td></td><td></td><td></td><td></td><td></td><td></td><td>13</td><td></td><td></td><td></td></tr> </table>			70		68	67	66	65							49		47			44	43	42			73			32		30			27								13			
			70		68	67	66	65																																											
				49		47			44	43	42																																								
		73			32		30			27																																									
							13																																												
D	AVAILABLE	NOT APPLICABLE	34566-2063	0	H	ST GRY	<table border="1"> <tr><td></td><td></td><td>78</td><td></td><td></td><td></td><td></td><td></td><td>72</td><td>71</td><td>70</td></tr> <tr><td></td><td></td><td>58</td><td>57</td><td>56</td><td></td><td></td><td>53</td><td>52</td><td></td><td>50</td></tr> <tr><td>40</td><td></td><td></td><td>37</td><td></td><td>35</td><td>34</td><td></td><td>32</td><td></td><td>30</td></tr> <tr><td>20</td><td>19</td><td>18</td><td>17</td><td>16</td><td></td><td>14</td><td></td><td>12</td><td></td><td>10</td></tr> </table>			78						72	71	70			58	57	56			53	52		50	40			37		35	34		32		30	20	19	18	17	16		14		12		10
			78						72	71	70																																								
			58	57	56			53	52		50																																								
40			37		35	34		32		30																																									
20	19	18	17	16		14		12		10																																									
C	AVAILABLE	NOT APPLICABLE	34566-2073	0	H	ST GRY	<table border="1"> <tr><td></td><td></td><td>78</td><td></td><td></td><td></td><td></td><td></td><td>72</td><td>71</td><td>70</td></tr> <tr><td></td><td></td><td>58</td><td>57</td><td>56</td><td></td><td></td><td>53</td><td>52</td><td></td><td>50</td></tr> <tr><td>40</td><td></td><td></td><td>37</td><td></td><td>35</td><td>34</td><td></td><td>32</td><td></td><td>30</td></tr> <tr><td>20</td><td>19</td><td>18</td><td>17</td><td>16</td><td></td><td></td><td></td><td>12</td><td></td><td></td></tr> </table>			78						72	71	70			58	57	56			53	52		50	40			37		35	34		32		30	20	19	18	17	16				12		
			78						72	71	70																																								
			58	57	56			53	52		50																																								
40			37		35	34		32		30																																									
20	19	18	17	16				12																																											
B	AVAILABLE	NOT APPLICABLE	34566-2083	0	H	ST GRY	<table border="1"> <tr><td></td><td></td><td>78</td><td></td><td></td><td></td><td></td><td></td><td>72</td><td>71</td><td>70</td></tr> <tr><td></td><td></td><td>58</td><td>57</td><td>56</td><td></td><td></td><td>53</td><td>52</td><td>51</td><td>50</td></tr> <tr><td>40</td><td></td><td></td><td>37</td><td></td><td>35</td><td>34</td><td></td><td>32</td><td></td><td>30</td></tr> <tr><td>20</td><td>19</td><td>18</td><td>17</td><td>16</td><td></td><td></td><td></td><td>12</td><td></td><td></td></tr> </table>			78						72	71	70			58	57	56			53	52	51	50	40			37		35	34		32		30	20	19	18	17	16				12		
			78						72	71	70																																								
			58	57	56			53	52	51	50																																								
40			37		35	34		32		30																																									
20	19	18	17	16				12																																											
A																																																			
RELEASE STATUS		RELEASE DATE																																																	
19	18	17	16	15	14	13	12																																												
							11																																												

E

AVAILABLE	NOT APPLICABLE	34566-2153	0	A	BLACK
-----------	----------------	------------	---	---	-------

		70		68	67	66	65				
			49		47			44	43	42	41
73					32		30			27	25
							13				

D

AVAILABLE	NOT APPLICABLE	34566-2163	0	A	BLACK
-----------	----------------	------------	---	---	-------

		70			67	66					61
			49		47		45	44	43	42	41
73					32					27	
						15		13		11	9

C

AVAILABLE	NOT APPLICABLE	34566-2173	0	A	BLACK
-----------	----------------	------------	---	---	-------

		70			67	66	65				61
			49		47		45	44	43	42	41
73					32		30			27	25
						15		13		11	9

B

AVAILABLE	NOT APPLICABLE	34566-2183	0	A	BLACK
-----------	----------------	------------	---	---	-------

		70			67	66	65				
			49		47			44	43	42	41
73					32					27	
						15		13			9

A

RELEASE STATUS		RELEASE DATE	
----------------	--	--------------	--





E

AVAILABLE	NOT APPLICABLE	34566-2353	0	A	BLACK
-----------	----------------	------------	---	---	-------

72		70			67	66	65		
			49		47			44	43
73					32		30		27
					15	14	13		

D

AVAILABLE	NOT APPLICABLE	34566-2363	0	C	BLUE
-----------	----------------	------------	---	---	------

72		70			67	66			63
52	51					46		44	
73					32		30		27
					15	14			

C

AVAILABLE	NOT APPLICABLE	34566-2373	0	B	ST GRY
-----------	----------------	------------	---	---	--------

					68	67	66	65	64	
	51	50	49		48	47	46	45		43
73					32	31	30			
					16	15	14	13		

B

AVAILABLE	NOT APPLICABLE	34566-2383	0	B	ST GRY
-----------	----------------	------------	---	---	--------

								65		
		50	49		48		46			
73								29		
					15					

A

RELEASE STATUS		RELEASE DATE	
----------------	--	--------------	--



E

AVAILABLE	NOT APPLICABLE	34566-2543	0	C	BLUE
-----------	----------------	------------	---	---	------

72		70				66			63
52	51					46		44	
73				32		30			27
					15	14			

D

AVAILABLE	NOT APPLICABLE	34566-2553	9	B	ST GRY
-----------	----------------	------------	---	---	--------

72	71	70		68	67	66			
52	51	50		48	47	46			
73				32	31	30	29	28	27
				16	15	14	13		

C

AVAILABLE	NOT APPLICABLE	34566-2563	9	A	BLACK
-----------	----------------	------------	---	---	-------

			69						63
52	51	50	49					44	43
73				32			29	28	27
				16		14	13	12	11

B

AVAILABLE	NOT APPLICABLE	34566-2573	9	C	BLUE
-----------	----------------	------------	---	---	------

72		70			67	66			63
52	51					46		44	
73						30			
					15	14			

A

RELEASE STATUS		RELEASE DATE
----------------	--	--------------

E	AVAILABLE	NOT APPLICABLE	34566-2643	0	A	BLACK	<table border="1"> <tr><td></td><td>71</td><td></td><td>69</td><td>68</td><td>67</td><td></td><td>65</td><td>64</td><td>63</td><td></td><td>61</td><td></td></tr> <tr><td></td><td></td><td>50</td><td>49</td><td></td><td>47</td><td></td><td></td><td></td><td></td><td></td><td>41</td><td></td></tr> <tr><td colspan="4">73</td><td>32</td><td>31</td><td>30</td><td>29</td><td>28</td><td>27</td><td></td><td></td><td>24</td></tr> <tr><td></td><td></td><td></td><td></td><td>16</td><td></td><td></td><td>13</td><td>12</td><td>11</td><td>10</td><td>9</td><td></td></tr> </table>		71		69	68	67		65	64	63		61				50	49		47						41		73				32	31	30	29	28	27			24					16			13	12	11	10	9	
		71		69	68	67		65	64	63		61																																															
		50	49		47						41																																																
73				32	31	30	29	28	27			24																																															
				16			13	12	11	10	9																																																
D	AVAILABLE	NOT APPLICABLE	34566-2653	0	A	BLACK	<table border="1"> <tr><td></td><td>71</td><td></td><td>69</td><td>68</td><td>67</td><td></td><td>65</td><td>64</td><td></td><td></td><td>61</td><td></td></tr> <tr><td></td><td></td><td>50</td><td>49</td><td></td><td>47</td><td></td><td></td><td></td><td></td><td></td><td>41</td><td></td></tr> <tr><td colspan="4">73</td><td>32</td><td>31</td><td>30</td><td>29</td><td>28</td><td>27</td><td></td><td></td><td>24</td></tr> <tr><td></td><td></td><td></td><td></td><td>16</td><td></td><td></td><td></td><td></td><td>11</td><td>10</td><td>9</td><td></td></tr> </table>		71		69	68	67		65	64			61				50	49		47						41		73				32	31	30	29	28	27			24					16					11	10	9	
		71		69	68	67		65	64			61																																															
		50	49		47						41																																																
73				32	31	30	29	28	27			24																																															
				16					11	10	9																																																
C	AVAILABLE	NOT APPLICABLE	34566-2663	0	H	ST GRY	<table border="1"> <tr><td></td><td>79</td><td>78</td><td>77</td><td>76</td><td>75</td><td>74</td><td>73</td><td>72</td><td>71</td><td>70</td><td>69</td><td>68</td></tr> <tr><td>60</td><td>59</td><td>58</td><td>57</td><td>56</td><td></td><td></td><td>53</td><td></td><td></td><td>50</td><td></td><td></td></tr> <tr><td>40</td><td>39</td><td>38</td><td>37</td><td></td><td>35</td><td>34</td><td></td><td>32</td><td></td><td>30</td><td>29</td><td></td></tr> <tr><td>20</td><td>19</td><td>18</td><td>17</td><td></td><td></td><td></td><td>13</td><td>12</td><td></td><td></td><td></td><td>8</td></tr> </table>		79	78	77	76	75	74	73	72	71	70	69	68	60	59	58	57	56			53			50			40	39	38	37		35	34		32		30	29		20	19	18	17				13	12				8
		79	78	77	76	75	74	73	72	71	70	69	68																																														
60	59	58	57	56			53			50																																																	
40	39	38	37		35	34		32		30	29																																																
20	19	18	17				13	12				8																																															
B	AVAILABLE	NOT APPLICABLE	34566-2673	0	H	ST GRY	<table border="1"> <tr><td></td><td>79</td><td>78</td><td>77</td><td>76</td><td>75</td><td>74</td><td>73</td><td>72</td><td>71</td><td>70</td><td>69</td><td>68</td></tr> <tr><td>60</td><td>59</td><td>58</td><td>57</td><td>56</td><td></td><td></td><td>53</td><td>52</td><td></td><td>50</td><td></td><td></td></tr> <tr><td>40</td><td>39</td><td>38</td><td>37</td><td></td><td>35</td><td>34</td><td></td><td>32</td><td></td><td>30</td><td>29</td><td></td></tr> <tr><td>20</td><td>19</td><td>18</td><td>17</td><td>16</td><td></td><td></td><td>13</td><td>12</td><td></td><td></td><td></td><td>8</td></tr> </table>		79	78	77	76	75	74	73	72	71	70	69	68	60	59	58	57	56			53	52		50			40	39	38	37		35	34		32		30	29		20	19	18	17	16			13	12				8
		79	78	77	76	75	74	73	72	71	70	69	68																																														
60	59	58	57	56			53	52		50																																																	
40	39	38	37		35	34		32		30	29																																																
20	19	18	17	16			13	12				8																																															

E

AVAILABLE	NOT APPLICABLE	34566-2743	0	C	BLUE
-----------	----------------	------------	---	---	------

72		70			67	66			63	62
52	51					46		44		42
73				32		30				26
					15	14				10

D

AVAILABLE	NOT APPLICABLE	34566-2753	0	A	BLACK
-----------	----------------	------------	---	---	-------

									63	62
52	51		49					44	43	42
73				32			29	28	27	26
				16	15		13	12	11	10

C

AVAILABLE	NOT APPLICABLE	34566-2763	0	B	ST GRY
-----------	----------------	------------	---	---	--------

72	71	70		68	67	66				62
52	51	50		48	47	46				42
73				32	31	30	29	28	27	26
				16	15	14	13			10

B

AVAILABLE	NOT APPLICABLE	34566-2773	0	H	ST GRY
-----------	----------------	------------	---	---	--------

							53			
								32		
20										

A

AVAILABLE	NOT APPLICABLE	34566-2783	9	H	ST GRY
-----------	----------------	------------	---	---	--------

							53			
								32		
20										

RELEASE STATUS		RELEASE DATE	
----------------	--	--------------	--

E

AVAILABLE	NOT APPLICABLE	34566-2853	0	B	ST GRY
-----------	----------------	------------	---	---	--------

72	71	70	69	68	67	66	65	64	63	
52	51	50	49	48		46		44		
73				32	31	30	29	28	27	
				16		14	13	12	11	1

D

AVAILABLE	NOT APPLICABLE	34566-2863	0	A	BLACK
-----------	----------------	------------	---	---	-------

72	71	70	69	68	67	66		64	63	62
52			49	48		46		44	43	42
73				32			29	28	27	
				16		14	13	12	11	

C

AVAILABLE	NOT APPLICABLE	34566-2873	0	B	ST GRY
-----------	----------------	------------	---	---	--------

72	71	70	69	68	67	66				
52	51	50	49	48	47					
73										
					15				11	10

B

AVAILABLE	NOT APPLICABLE	34566-2883	0	A	BLACK
-----------	----------------	------------	---	---	-------

		70	69						63	62
52	51		49					44	43	42
73				32			29	28	27	26
				16			13	12	11	10

A

RELEASE STATUS		RELEASE DATE	
----------------	--	--------------	--

E

AVAILABLE	NOT APPLICABLE	34566-2943	0	B	ST GRY
-----------	----------------	------------	---	---	--------

				68	67			6
						46	45	
73				32		30	29	2

D

AVAILABLE	NOT APPLICABLE	34566-2953	0	B	ST GRY
-----------	----------------	------------	---	---	--------

				68	67			6
						46	45	
73				32		30	29	2

C

AVAILABLE	NOT APPLICABLE	34566-2963	0	H	ST GRY
-----------	----------------	------------	---	---	--------

	79					74	73	72
	59					54	53	52
		38					33	
					15	14		

B

AVAILABLE	NOT APPLICABLE	34566-2973	0	G	BLUE
-----------	----------------	------------	---	---	------

80		78	77		75	74	73	72
60		58	57		55	54		53
40		38	37				33	32
20		18	17					

A

RELEASE STATUS		RELEASE DATE
----------------	--	--------------



E

AVAILABLE	NOT APPLICABLE	34566-9953	0	A	BLACK
-----------	----------------	------------	---	---	-------

				67				
	51			48		46	45	4
73								
				15	14			

D

AVAILABLE	NOT APPLICABLE	34566-9963	0	B	ST GRY
-----------	----------------	------------	---	---	--------

				68	67			6
						46	45	
73				32		30	29	2
					15		13	

C

AVAILABLE	NOT APPLICABLE	34566-9973	0	B	ST GRY
-----------	----------------	------------	---	---	--------

				68	67			6
						46	45	
73				32		30	29	2
					15		13	

B

A

RELEASE STATUS		RELEASE DATE	
----------------	--	--------------	--

FORMAT: master-ib-prod-D  
 REVISION: 10  
 DATE: 2015/12/14

E	AVAILABLE	APPLICABLE	34566-3043	0	C	BLUE	<table border="1"> <tr><td>40</td><td>39</td><td>37</td><td>36</td><td>35</td><td>34</td><td>32</td></tr> <tr><td>20</td><td>19</td><td>18</td><td>17</td><td>16</td><td></td><td>13</td><td>12</td></tr> </table>	40	39	37	36	35	34	32	20	19	18	17	16		13	12																	
	40	39	37	36	35	34	32																																
	20	19	18	17	16		13	12																															
AVAILABLE	NOT APPLICABLE	34566-3043	0	C	BLUE	<table border="1"> <tr><td>72</td><td></td><td>70</td><td></td><td>68</td><td></td><td>66</td><td></td></tr> <tr><td>52</td><td>51</td><td></td><td></td><td>48</td><td>47</td><td>46</td><td>44</td></tr> <tr><td colspan="4">73</td><td>32</td><td></td><td>30</td><td></td></tr> <tr><td colspan="4"></td><td></td><td>15</td><td>14</td><td>13</td></tr> </table>	72		70		68		66		52	51			48	47	46	44	73				32		30							15	14	13	
72		70		68		66																																	
52	51			48	47	46	44																																
73				32		30																																	
					15	14	13																																
D	AVAILABLE	NOT APPLICABLE	34566-3053	0	C	BLUE	<table border="1"> <tr><td>72</td><td></td><td>70</td><td></td><td>68</td><td></td><td>66</td><td></td></tr> <tr><td>52</td><td>51</td><td></td><td></td><td>48</td><td>47</td><td>46</td><td>44</td></tr> <tr><td colspan="4">73</td><td>32</td><td></td><td>30</td><td></td></tr> <tr><td colspan="4"></td><td></td><td>15</td><td>14</td><td>13</td></tr> </table>	72		70		68		66		52	51			48	47	46	44	73				32		30							15	14	13
	72		70		68		66																																
	52	51			48	47	46	44																															
73				32		30																																	
					15	14	13																																
AVAILABLE	NOT APPLICABLE	34566-3063	0	A	BLACK	<table border="1"> <tr><td></td><td>71</td><td></td><td>69</td><td></td><td></td><td>65</td><td>64</td></tr> <tr><td>52</td><td>51</td><td></td><td>49</td><td></td><td></td><td>45</td><td>44</td></tr> <tr><td colspan="4">73</td><td>32</td><td></td><td>30</td><td>28</td></tr> <tr><td colspan="4"></td><td>16</td><td></td><td></td><td>12</td></tr> </table>		71		69			65	64	52	51		49			45	44	73				32		30	28					16			12	
	71		69			65	64																																
52	51		49			45	44																																
73				32		30	28																																
				16			12																																
C																																							
B																																							
A																																							

RELEASE STATUS		RELEASE DATE	
----------------	--	--------------	--

E	AVAILABLE	NOT APPLICABLE	34566-3123	0	B	ST GRY	<table border="1"> <tr> <td>72</td><td></td><td>70</td><td></td><td>68</td><td>67</td><td>66</td><td></td><td></td><td>63</td><td>62</td><td></td> </tr> <tr> <td>52</td><td></td><td>50</td><td></td><td>48</td><td></td><td>46</td><td></td><td></td><td></td><td></td><td></td> </tr> <tr> <td colspan="4">73</td> <td>32</td><td>31</td><td>30</td><td>29</td><td>28</td><td>27</td><td>26</td><td>25</td> </tr> <tr> <td colspan="4"></td> <td>16</td><td></td><td></td><td></td><td></td><td></td><td>10</td><td></td> </tr> </table>	72		70		68	67	66			63	62		52		50		48		46						73				32	31	30	29	28	27	26	25					16						10	
	72		70		68	67	66			63	62																																												
	52		50		48		46																																																
	73				32	31	30	29	28	27	26	25																																											
				16						10																																													
AVAILABLE	NOT APPLICABLE	34566-3133	0	C	BLUE	<table border="1"> <tr> <td>72</td><td></td><td>70</td><td></td><td>68</td><td>67</td><td>66</td><td></td><td></td><td>63</td><td>62</td><td></td> </tr> <tr> <td>52</td><td>51</td><td></td><td></td><td>48</td><td>47</td><td>46</td><td></td><td>44</td><td></td><td>42</td><td></td> </tr> <tr> <td colspan="4">73</td> <td>32</td><td></td><td>30</td><td></td><td></td><td></td><td>26</td><td>25</td> </tr> <tr> <td colspan="4"></td> <td></td><td>15</td><td>14</td><td></td><td></td><td></td><td>10</td><td></td> </tr> </table>	72		70		68	67	66			63	62		52	51			48	47	46		44		42		73				32		30				26	25						15	14				10		
72		70		68	67	66			63	62																																													
52	51			48	47	46		44		42																																													
73				32		30				26	25																																												
					15	14				10																																													
AVAILABLE	NOT APPLICABLE	34566-3143	0	C	BLUE	<table border="1"> <tr> <td>72</td><td></td><td>70</td><td></td><td></td><td></td><td>66</td><td></td><td></td><td>63</td><td>62</td><td></td> </tr> <tr> <td>52</td><td>51</td><td></td><td></td><td></td><td></td><td>46</td><td></td><td>44</td><td></td><td>42</td><td></td> </tr> <tr> <td colspan="4">73</td> <td>32</td><td></td><td>30</td><td></td><td></td><td></td><td>26</td><td>25</td> </tr> <tr> <td colspan="4"></td> <td></td><td>15</td><td>14</td><td></td><td></td><td></td><td>10</td><td></td> </tr> </table>	72		70				66			63	62		52	51					46		44		42		73				32		30				26	25						15	14				10		
72		70				66			63	62																																													
52	51					46		44		42																																													
73				32		30				26	25																																												
					15	14				10																																													
AVAILABLE	NOT APPLICABLE	34566-3153	0	A	BLACK	<table border="1"> <tr> <td></td><td></td><td>70</td><td>69</td><td></td><td></td><td></td><td></td><td></td><td>63</td><td></td><td></td> </tr> <tr> <td>52</td><td>51</td><td></td><td>49</td><td></td><td>47</td><td></td><td></td><td>44</td><td>43</td><td>42</td><td>41</td> </tr> <tr> <td colspan="4">73</td> <td>32</td><td></td><td></td><td></td><td>28</td><td></td><td>26</td><td>25</td> </tr> <tr> <td colspan="4"></td> <td>16</td><td></td><td></td><td></td><td>12</td><td></td><td>10</td><td></td> </tr> </table>			70	69						63			52	51		49		47			44	43	42	41	73				32				28		26	25					16				12		10		
		70	69						63																																														
52	51		49		47			44	43	42	41																																												
73				32				28		26	25																																												
				16				12		10																																													
D																																																							
C																																																							
B																																																							
A																																																							
<table border="1"> <tr> <td>RELEASE STATUS</td> <td></td> <td>RELEASE DATE</td> <td></td> <td></td> <td></td> <td></td> </tr> </table>							RELEASE STATUS		RELEASE DATE																																														
RELEASE STATUS		RELEASE DATE																																																					
19	18	17	16	15	14	13																																																	
12	11																																																						

E

AVAILABLE	NOT APPLICABLE	34566-3213	0	C	BLUE
-----------	----------------	------------	---	---	------

72		70			67	66			63
52	51					46		44	
73				32		30			
					15	14			

D

AVAILABLE	NOT APPLICABLE	34566-3223	0	C	BLUE
-----------	----------------	------------	---	---	------

72		70			67	66			63
52	51					46		44	
73				32		30			27
					15	14			

C

AVAILABLE	NOT APPLICABLE	34566-3233	0	A	BLACK
-----------	----------------	------------	---	---	-------

		70	69						63
52	51		49					44	43
73				32			29	28	27
				16	15		13	12	11

B

AVAILABLE	NOT APPLICABLE	34566-3243	0	C	BLUE
-----------	----------------	------------	---	---	------

72		70				66			63
52	51					46		44	
73				32		30			
					15	14			

A

RELEASE STATUS		RELEASE DATE
----------------	--	--------------

E	AVAILABLE	NOT APPLICABLE	34566-3293	0	B	ST GRY	<table border="1"> <tr> <td>32</td><td>31</td><td>30</td><td>48</td><td>47</td><td></td><td></td><td></td><td></td><td></td> </tr> <tr> <td colspan="4">73</td> <td>32</td><td>31</td><td>30</td><td>29</td><td>28</td><td></td> </tr> <tr> <td colspan="4"></td> <td>16</td><td>15</td><td>14</td><td>13</td><td></td><td></td> </tr> </table>	32	31	30	48	47						73				32	31	30	29	28						16	15	14	13												
	32	31	30	48	47																																										
	73				32	31	30	29	28																																						
					16	15	14	13																																							
AVAILABLE	NOT APPLICABLE	34566-3313	0	C	BLUE	<table border="1"> <tr> <td>72</td><td></td><td>70</td><td></td><td></td><td></td><td></td><td></td><td></td><td></td> </tr> <tr> <td>52</td><td>51</td><td></td><td></td><td></td><td></td><td></td><td>46</td><td></td><td>44</td> </tr> <tr> <td colspan="4">73</td> <td>32</td><td></td><td>30</td><td></td><td></td><td></td> </tr> <tr> <td colspan="4"></td> <td></td><td>15</td><td>14</td><td></td><td></td><td></td> </tr> </table>	72		70								52	51						46		44	73				32		30									15	14				
72		70																																													
52	51						46		44																																						
73				32		30																																									
					15	14																																									
AVAILABLE	NOT APPLICABLE	34566-3323	0	B	ST GRY	<table border="1"> <tr> <td></td><td></td><td></td><td></td><td>68</td><td>67</td><td>66</td><td>65</td><td>64</td><td></td> </tr> <tr> <td></td><td></td><td></td><td>49</td><td>48</td><td></td><td>46</td><td>45</td><td>44</td><td></td> </tr> <tr> <td colspan="4">73</td> <td>32</td><td></td><td>30</td><td>29</td><td>28</td><td></td> </tr> <tr> <td colspan="4"></td> <td>16</td><td></td><td></td><td></td><td></td><td></td> </tr> </table>					68	67	66	65	64					49	48		46	45	44		73				32		30	29	28						16						
				68	67	66	65	64																																							
			49	48		46	45	44																																							
73				32		30	29	28																																							
				16																																											
C	AVAILABLE	NOT APPLICABLE	34566-3333	0	A	BLACK	<table border="1"> <tr> <td>72</td><td>71</td><td>70</td><td>69</td><td>68</td><td></td><td></td><td>65</td><td>64</td><td></td> </tr> <tr> <td>52</td><td>51</td><td>50</td><td>49</td><td></td><td>47</td><td></td><td></td><td></td><td></td> </tr> <tr> <td colspan="4">73</td> <td>32</td><td>31</td><td>30</td><td>29</td><td>28</td><td></td> </tr> <tr> <td colspan="4"></td> <td>16</td><td></td><td></td><td>13</td><td>12</td><td></td> </tr> </table>	72	71	70	69	68			65	64		52	51	50	49		47					73				32	31	30	29	28						16			13	12	
72	71	70	69	68			65	64																																							
52	51	50	49		47																																										
73				32	31	30	29	28																																							
				16			13	12																																							

B																				
A																				

RELEASE STATUS		RELEASE DATE																		
19		18		17		16		15		14		13		12		11				

FORMAT: master-ib-prod-D  
 REVISION: 10  
 DATE: 2015/12/14

E

D

C

B

A

AVAILABLE	NOT APPLICABLE	34566-3393	G	0	C	BLUE
AVAILABLE	NOT APPLICABLE	34566-3413	G	0	A	BLACK
AVAILABLE	NOT APPLICABLE	34566-3423	G	9	C	BLUE

RELEASE STATUS		RELEASE DATE	
----------------	--	--------------	--



E

AVAILABLE	NOT APPLICABLE	34566-3573	9	C	BLUE
-----------	----------------	------------	---	---	------

		70	69	68				
52	51	50	49	48	47			44
73				32			29	28
				16	15	14	13	12

D

AVAILABLE	NOT APPLICABLE	34566-3583	9	A	BLACK
-----------	----------------	------------	---	---	-------

		70	69					
52	51	50	49					44
73				32			29	28
				16	15	14	13	12

C

AVAILABLE	NOT APPLICABLE	34566-3593	0	A	BLACK
-----------	----------------	------------	---	---	-------

	71		69					64
52	51		49				45	44
73				32		30		28
				16	15			12

B

AVAILABLE	NOT APPLICABLE	34566-3613	0	B	ST GRY
-----------	----------------	------------	---	---	--------

				68	67			64
						46	45	
73				32		30	29	28

A

RELEASE STATUS		RELEASE DATE	
----------------	--	--------------	--

FORMAT: master-lb-prod-D  
 REVISION: 10  
 DATE: 2015/12/14



E

AVAILABLE	NOT APPLICABLE	34566-3673	9	C	BLUE
-----------	----------------	------------	---	---	------

	71	70	69	68	67		65		63
	51	50	49	48			45	44	43
73					31	30	29	28	27
				16	15	14			

D

AVAILABLE	NOT APPLICABLE	34566-3683	9	H	ST GRY
-----------	----------------	------------	---	---	--------

								32	
20					15				

C

AVAILABLE	NOT APPLICABLE	34566-3693	0	C	BLUE
-----------	----------------	------------	---	---	------

72		70		68	67	66			6
52	51			48	47	46		44	
73				32		30			2
					15	14			

B

AVAILABLE	NOT APPLICABLE	34566-3713	0	C	BLUE
-----------	----------------	------------	---	---	------

72		70		68	67	66			6
52	51			48	47	46		44	
73				32		30			2
					15	14			

A

RELEASE STATUS		RELEASE DATE
----------------	--	--------------

E

AVAILABLE	NOT APPLICABLE	34566-3773	0	A	BLACK
-----------	----------------	------------	---	---	-------

		70	69						63		
52	51	50	49						44	43	42
73				32					28		26
				16	15	14			12		10

D

AVAILABLE	NOT APPLICABLE	34566-3783	0	A	BLACK
-----------	----------------	------------	---	---	-------

		70	69						63		
52	51	50	49						44	43	42
73				32					28		26
				16	15	14			12		10

C

AVAILABLE	NOT APPLICABLE	34566-3793	0	A	BLACK
-----------	----------------	------------	---	---	-------

	71	70							64	63	
52	51		49					45	44	43	42
73				32		30			28		26
				16	15				12		10

B

AVAILABLE	NOT APPLICABLE	34566-3813	0	C	BLUE
-----------	----------------	------------	---	---	------

72		70		68		66				63	62
52	51			48	47	46			44		42
73				32		30					26
					15	14	13				10

A

RELEASE STATUS		RELEASE DATE	
----------------	--	--------------	--



E	AVAILABLE	NOT APPLICABLE	34566-3953	0	C	BLUE	73	32	30			26	2					
								15	14	13								
	AVAILABLE	NOT APPLICABLE	34566-3963	0	C	BLUE	72		70		68	67	66			63	62	
							52	51			48	47	46		44		42	
D							73				32		30				26	2
											15	14					10	9
	AVAILABLE	NOT APPLICABLE	34566-3973	0	C	BLUE	72		70		68	67				63	62	
							52	51			48	47	46		44		42	
C							73				32		30				26	2
											15	14						
	AVAILABLE	NOT APPLICABLE	34566-3983	0	A	BLACK	72	71	70	69					64	63		
							52	51		49				45	44	43	42	4
B							73				32		30		28		26	
											16	15			12		10	
	AVAILABLE	NOT APPLICABLE	34566-3993	0	A	BLACK			70	69						63	62	6
							52	51		49				44	43	42	4	
A							73				32			29	28	27	26	
											16	15		13	12	11	10	

RELEASE STATUS		RELEASE DATE	
----------------	--	--------------	--

FORMAT: master-ib-prod-0  
 REVISION: 0  
 DATE: 2015/12/14

E

D

C

B

A

	AVAILABLE	NOT APPLICABLE	34566-4053	0	A	BLACK
	AVAILABLE	NOT APPLICABLE	34566-4063	0	B	ST GRY
	AVAILABLE	NOT APPLICABLE	34566-4073	0	A	BLACK

73		32	30	28
		16	15	12

72		69	67	66	65	
		49	47	46		44
73			31	30	29	28
		16	15	14	13	

			68	67		64
					46	45
73			32		30	29
				15		13

72		70		66	
52	51			46	44
73			32	30	
				15	14

RELEASE STATUS		RELEASE DATE
----------------	--	--------------

E	AVAILABLE	NOT APPLICABLE	34566-4143	0	B	ST GRY	<table border="1"> <tr><td></td><td></td><td></td><td></td><td>68</td><td>67</td><td></td><td></td><td>64</td><td></td><td></td><td></td><td></td><td></td></tr> <tr><td></td><td></td><td></td><td></td><td></td><td></td><td>46</td><td>45</td><td></td><td></td><td></td><td></td><td></td><td></td></tr> <tr><td colspan="4">73</td><td>32</td><td></td><td>30</td><td>29</td><td>28</td><td>27</td><td></td><td></td><td>10</td><td>9</td></tr> <tr><td colspan="4"></td><td></td><td></td><td></td><td></td><td></td><td></td><td></td><td></td><td></td><td></td></tr> </table>					68	67			64												46	45							73				32		30	29	28	27			10	9														
					68	67			64																																																						
							46	45																																																							
	73				32		30	29	28	27			10	9																																																	
D	AVAILABLE	NOT APPLICABLE	34566-4153	0	B	ST GRY	<table border="1"> <tr><td>72</td><td></td><td>70</td><td></td><td>68</td><td></td><td>66</td><td></td><td></td><td></td><td></td><td></td><td></td><td></td></tr> <tr><td>52</td><td></td><td>50</td><td></td><td>48</td><td></td><td>46</td><td></td><td>44</td><td></td><td></td><td></td><td></td><td></td></tr> <tr><td colspan="4">73</td><td>32</td><td>31</td><td>30</td><td>29</td><td>28</td><td>27</td><td>26</td><td>25</td><td></td><td></td></tr> <tr><td colspan="4"></td><td>16</td><td></td><td></td><td></td><td></td><td></td><td></td><td></td><td>10</td><td>9</td></tr> </table>	72		70		68		66								52		50		48		46		44						73				32	31	30	29	28	27	26	25							16								10	9
	72		70		68		66																																																								
	52		50		48		46		44																																																						
	73				32	31	30	29	28	27	26	25																																																			
				16								10	9																																																		
C	AVAILABLE	NOT APPLICABLE	34566-4163	0	B	ST GRY	<table border="1"> <tr><td>72</td><td></td><td>70</td><td></td><td>68</td><td></td><td>66</td><td></td><td></td><td></td><td></td><td></td><td></td><td></td></tr> <tr><td>52</td><td></td><td>50</td><td></td><td>48</td><td></td><td>46</td><td></td><td></td><td></td><td></td><td></td><td></td><td></td></tr> <tr><td colspan="4">73</td><td>32</td><td>31</td><td>30</td><td>29</td><td>28</td><td>27</td><td>26</td><td>25</td><td></td><td></td></tr> <tr><td colspan="4"></td><td>16</td><td></td><td></td><td></td><td></td><td></td><td></td><td></td><td>10</td><td>9</td></tr> </table>	72		70		68		66								52		50		48		46								73				32	31	30	29	28	27	26	25							16								10	9
	72		70		68		66																																																								
	52		50		48		46																																																								
	73				32	31	30	29	28	27	26	25																																																			
				16								10	9																																																		
A	AVAILABLE	NOT APPLICABLE	34566-4173	0	A	BLACK	<table border="1"> <tr><td>72</td><td>71</td><td>70</td><td>69</td><td></td><td></td><td></td><td></td><td>64</td><td>63</td><td></td><td></td><td></td><td></td></tr> <tr><td>52</td><td>51</td><td></td><td>49</td><td></td><td>47</td><td></td><td>45</td><td>44</td><td>43</td><td>42</td><td>41</td><td></td><td></td></tr> <tr><td colspan="4">73</td><td>32</td><td></td><td>30</td><td></td><td>28</td><td></td><td>26</td><td>25</td><td></td><td></td></tr> <tr><td colspan="4"></td><td>16</td><td>15</td><td></td><td></td><td>12</td><td></td><td>10</td><td>9</td><td></td><td></td></tr> </table>	72	71	70	69					64	63					52	51		49		47		45	44	43	42	41			73				32		30		28		26	25							16	15			12		10	9		
	72	71	70	69					64	63																																																					
	52	51		49		47		45	44	43	42	41																																																			
	73				32		30		28		26	25																																																			
				16	15			12		10	9																																																				

RELEASE STATUS		RELEASE DATE	
----------------	--	--------------	--



E

AVAILABLE	NOT APPLICABLE	34566-4343	0	A	BLACK
-----------	----------------	------------	---	---	-------

72	71	70	69					64	63			60	59	58
52	51		49		47		45	44	43	42	41			38
73				32		30		28		26	25			
73				16	15			12		10	9			

D

AVAILABLE	NOT APPLICABLE	34566-4353	0	C	BLUE
-----------	----------------	------------	---	---	------

72		70		68					63	62			59	58
52	51			48	47			44		42		40	39	
73				32		30				26	25		23	22
73					15	14	13						7	6

C

AVAILABLE	NOT APPLICABLE	34566-4363	0	A	BLACK
-----------	----------------	------------	---	---	-------

		70	69						63	62	61	60		58
52	51		49					44	43	42	41			
73				32			29	28	27	26			23	
73				16	15		13	12	11	10		8		

B

AVAILABLE	NOT APPLICABLE	34566-4373	0	A	BLACK
-----------	----------------	------------	---	---	-------

		70	69						63					58
52	51		49		47			44	43	42	41	40		
73				32				28		26				
73				16				12		10				

A

RELEASE STATUS		RELEASE DATE	
----------------	--	--------------	--



E

AVAILABLE	NOT APPLICABLE	34566-4443	9	A	BLACK
-----------	----------------	------------	---	---	-------

					67	66							
					48	47							41
73					32	31	30	29		27	26	25	
73					16	15	14	13		11	10	9	

D

AVAILABLE	NOT APPLICABLE	34566-4453	0	A	BLACK
-----------	----------------	------------	---	---	-------

72	71	70	69	68			65	64	63	62	61
52	51	50	49	48			46	45	44	43	42
73									28		
73									12	11	

C

AVAILABLE	NOT APPLICABLE	34566-4463	9	B	ST GRY
-----------	----------------	------------	---	---	--------

									63		
					48	47		45		43	42
73										26	
73									11		

B

AVAILABLE	NOT APPLICABLE	34566-4473	0	B	ST GRY
-----------	----------------	------------	---	---	--------

								64	63	62	
						47		45		43	42
73										26	25
73											

A

RELEASE STATUS		RELEASE DATE	
----------------	--	--------------	--

E	AVAILABLE	NOT APPLICABLE	34566-4533	0	A	BLACK	72		69	67	65	63														
									49	47		44	43													
	73								31	30	29	28														
			16	15	14	13							11													
D	AVAILABLE	NOT APPLICABLE	34566-4543	0	B	ST GRY				68	67		64	63												
												46	45		43											
	73								32		30	29	28	27												
														12												
C	AVAILABLE	NOT APPLICABLE	34566-4553	0	B	ST GRY				68	67		64	63												
												46	45		43											
	73								32		30	29	28	27												
														12												
B	AVAILABLE	NOT APPLICABLE	34566-4573	0	B	ST GRY				68	67		64	63												
												46	45		43											
	73								32		30	29	28	27												
														12												
A	RELEASE STATUS		RELEASE DATE																							
	19		18			17			16			15			14			13			12			11		

E	AVAILABLE	NOT APPLICABLE	34566-4643	0	B	ST GRY	<table border="1"> <tr><td>72</td><td></td><td>70</td><td></td><td>68</td><td></td><td>66</td><td></td><td></td><td></td><td></td><td></td></tr> <tr><td>52</td><td></td><td>50</td><td></td><td>48</td><td></td><td>46</td><td></td><td></td><td></td><td></td><td></td></tr> <tr><td colspan="4">73</td><td>32</td><td>31</td><td>30</td><td>29</td><td>28</td><td>27</td><td>26</td><td>25</td></tr> <tr><td colspan="4"></td><td>16</td><td></td><td></td><td></td><td></td><td></td><td>10</td><td></td></tr> </table>	72		70		68		66						52		50		48		46						73				32	31	30	29	28	27	26	25					16						10	
	72		70		68		66																																																
	52		50		48		46																																																
	73				32	31	30	29	28	27	26	25																																											
				16						10																																													
D	AVAILABLE	NOT APPLICABLE	34566-4653	0	A	BLACK	<table border="1"> <tr><td></td><td>71</td><td>70</td><td>69</td><td></td><td>67</td><td></td><td></td><td>64</td><td>63</td><td></td><td></td></tr> <tr><td>52</td><td>51</td><td></td><td>49</td><td></td><td>47</td><td></td><td>45</td><td>44</td><td>43</td><td>42</td><td>41</td></tr> <tr><td colspan="4">73</td><td>32</td><td></td><td>30</td><td></td><td>28</td><td></td><td>26</td><td></td></tr> <tr><td colspan="4"></td><td>16</td><td>15</td><td></td><td></td><td>12</td><td></td><td>10</td><td></td></tr> </table>		71	70	69		67			64	63			52	51		49		47		45	44	43	42	41	73				32		30		28		26						16	15			12		10	
		71	70	69		67			64	63																																													
52	51		49		47		45	44	43	42	41																																												
73				32		30		28		26																																													
				16	15			12		10																																													
C	AVAILABLE	NOT APPLICABLE	34566-4663	0	A	BLACK	<table border="1"> <tr><td></td><td>71</td><td>70</td><td>69</td><td></td><td></td><td></td><td></td><td>64</td><td>63</td><td></td><td></td></tr> <tr><td>52</td><td>51</td><td></td><td>49</td><td></td><td>47</td><td></td><td>45</td><td>44</td><td>43</td><td>42</td><td>41</td></tr> <tr><td colspan="4">73</td><td>32</td><td></td><td>30</td><td></td><td>28</td><td></td><td>26</td><td></td></tr> <tr><td colspan="4"></td><td>16</td><td>15</td><td></td><td></td><td>12</td><td></td><td>10</td><td></td></tr> </table>		71	70	69					64	63			52	51		49		47		45	44	43	42	41	73				32		30		28		26						16	15			12		10	
		71	70	69					64	63																																													
52	51		49		47		45	44	43	42	41																																												
73				32		30		28		26																																													
				16	15			12		10																																													
A	AVAILABLE	NOT APPLICABLE	34566-4673	0	A	BLACK	<table border="1"> <tr><td></td><td></td><td></td><td></td><td></td><td>67</td><td>66</td><td></td><td></td><td></td><td></td><td></td></tr> <tr><td></td><td></td><td></td><td></td><td></td><td>47</td><td></td><td></td><td></td><td></td><td></td><td>41</td></tr> <tr><td colspan="4">73</td><td>32</td><td>31</td><td>30</td><td>29</td><td></td><td>27</td><td>26</td><td>25</td></tr> <tr><td colspan="4"></td><td>16</td><td>15</td><td>14</td><td>13</td><td></td><td></td><td>10</td><td>9</td></tr> </table>						67	66											47						41	73				32	31	30	29		27	26	25					16	15	14	13			10	9
					67	66																																																	
					47						41																																												
73				32	31	30	29		27	26	25																																												
				16	15	14	13			10	9																																												

RELEASE STATUS		RELEASE DATE
----------------	--	--------------

FORMAT: master-ib-prod-D  
 REVISION: 10  
 DATE: 2015/12/14

E	AVAILABLE	NOT APPLICABLE	34566-4743	9	A	BLACK	<table border="1"> <tr> <td>72</td><td>71</td><td>70</td><td>69</td><td></td><td>67</td><td></td><td>65</td><td>64</td><td>63</td><td>62</td><td>61</td> </tr> <tr> <td>52</td><td>51</td><td>50</td><td>49</td><td>48</td><td>47</td><td></td><td>45</td><td>44</td><td>43</td><td>42</td><td>41</td> </tr> <tr> <td colspan="4">73</td> <td>32</td><td></td><td>30</td><td>29</td><td>28</td><td>27</td><td>26</td><td></td> </tr> <tr> <td colspan="4"></td> <td>16</td><td>15</td><td>14</td><td>13</td><td>12</td><td>11</td><td>10</td><td></td> </tr> </table>	72	71	70	69		67		65	64	63	62	61	52	51	50	49	48	47		45	44	43	42	41	73				32		30	29	28	27	26						16	15	14	13	12	11	10			
	72	71	70	69		67		65	64	63	62	61																																													
	52	51	50	49	48	47		45	44	43	42	41																																													
	73				32		30	29	28	27	26																																														
				16	15	14	13	12	11	10																																															
D	AVAILABLE	NOT APPLICABLE	34566-4753	0	B	ST.GRY	<table border="1"> <tr> <td></td><td></td><td></td><td></td><td></td><td>68</td><td>67</td><td></td><td></td><td>64</td><td></td><td></td><td></td> </tr> <tr> <td></td><td></td><td></td><td></td><td></td><td></td><td></td><td>46</td><td>45</td><td></td><td></td><td></td><td></td> </tr> <tr> <td colspan="4">73</td> <td>32</td><td></td><td>30</td><td>29</td><td>28</td><td>27</td><td></td><td></td> </tr> <tr> <td colspan="4"></td> <td></td><td>15</td><td></td><td>13</td><td></td><td></td><td></td><td>10</td> </tr> </table>						68	67			64											46	45					73				32		30	29	28	27								15		13				10
						68	67			64																																															
								46	45																																																
	73				32		30	29	28	27																																															
					15		13				10																																														
C	AVAILABLE	NOT APPLICABLE	34566-4763	0	B	ST.GRY	<table border="1"> <tr> <td></td><td></td><td></td><td></td><td></td><td>68</td><td>67</td><td></td><td></td><td>64</td><td></td><td></td><td></td> </tr> <tr> <td></td><td></td><td></td><td></td><td></td><td></td><td></td><td>46</td><td>45</td><td></td><td></td><td></td><td></td> </tr> <tr> <td colspan="4">73</td> <td>32</td><td></td><td>30</td><td>29</td><td>28</td><td>27</td><td></td><td></td> </tr> <tr> <td colspan="4"></td> <td></td><td>15</td><td></td><td>13</td><td></td><td></td><td></td><td>10</td> </tr> </table>						68	67			64											46	45					73				32		30	29	28	27								15		13				10
						68	67			64																																															
								46	45																																																
	73				32		30	29	28	27																																															
					15		13				10																																														
B	AVAILABLE	NOT APPLICABLE	34566-4773	0	B	ST.GRY	<table border="1"> <tr> <td></td><td></td><td></td><td></td><td></td><td>68</td><td>67</td><td></td><td></td><td>64</td><td></td><td></td><td></td> </tr> <tr> <td></td><td></td><td></td><td></td><td></td><td></td><td></td><td>46</td><td>45</td><td></td><td></td><td></td><td></td> </tr> <tr> <td colspan="4">73</td> <td>32</td><td></td><td>30</td><td>29</td><td>28</td><td>27</td><td></td><td></td> </tr> <tr> <td colspan="4"></td> <td></td><td>15</td><td></td><td>13</td><td></td><td></td><td></td><td>10</td> </tr> </table>						68	67			64											46	45					73				32		30	29	28	27								15		13				10
						68	67			64																																															
								46	45																																																
	73				32		30	29	28	27																																															
					15		13				10																																														
A	RELEASE STATUS		RELEASE DATE																																																						
	19	18	17	16	15	14	13	12	11																																																

E

AVAILABLE	NOT APPLICABLE	34566-4843	0	C	BLUE

73		15	14				10	9		
72		70		68	67	66		63	62	
52	51			48	47	46		44	42	
73				32		30		27	26	25
					15	14			10	9

D

AVAILABLE	NOT APPLICABLE	34566-4853	0	C	BLUE

72		70		68		66		63	62	
52	51			48	47	46		44	42	
73				32		30		27	26	25
					15	14			10	9

C

AVAILABLE	NOT APPLICABLE	34566-4863	0	C	BLUE

72		70		68		66		63	62	
52	51			48	47	46		44	42	
73				32		30		27	26	25
					15	14			10	9

B

AVAILABLE	NOT APPLICABLE	34566-4873	0	C	BLUE

72		70		68		66		63	62	
52	51			48	47	46		44	42	
73				32		30		27	26	25
					15	14			10	9

A

RELEASE STATUS		RELEASE DATE	
----------------	--	--------------	--

E

AVAILABLE	NOT APPLICABLE	34566-4943	0	A	BLACK
-----------	----------------	------------	---	---	-------

		70	69	68	67				63	62	
52	51	50	49						44	43	42
73				32	31		29	28	27	26	
				16	15	14	13	12	11	10	

D

AVAILABLE	NOT APPLICABLE	34566-4953	0	B	ST.GRAY
-----------	----------------	------------	---	---	---------

72	71	70	69	68	67	66	65	64	63	
52	51	50	49	48	47	46	45	44	43	
73				32	31	30	29	28	27	26
				16	15	14	13	12	11	10

C

AVAILABLE	NOT APPLICABLE	34566-4963	9	A	BLACK
-----------	----------------	------------	---	---	-------

72			69		67	66	65		63	
			49		47	46		44	43	42
73					31	30	29	28	27	26
				16	15	14	13		11	10

B

AVAILABLE	NOT APPLICABLE	34566-4973	9	B	ST.GRAY
-----------	----------------	------------	---	---	---------

				68	67			64		
						46	45	44	43	
73				32		30	29	28	27	
					15		13	12		10

A

RELEASE STATUS		RELEASE DATE	
----------------	--	--------------	--

E

AVAILABLE	NOT APPLICABLE	34566-5043	0	A	BLACK
-----------	----------------	------------	---	---	-------

73					31				

D

AVAILABLE	NOT APPLICABLE	34566-5053	0	B	ST.GRAY
-----------	----------------	------------	---	---	---------

					47				
73					31				

C

AVAILABLE	NOT APPLICABLE	34566-5063	9	H	ST.GRAY
-----------	----------------	------------	---	---	---------

80	79	78	77	76	75	74	73	72	71
60	59	58	57	56	55	54	53	52	51
40	39	38	37		35	34	33	32	
20	19	18	17			14	13	12	11

B

AVAILABLE	NOT APPLICABLE	34566-5073	9	A	BLACK
-----------	----------------	------------	---	---	-------

72	71	70	69	68	67	66	65	64	63
52	51	50	49	48	47	46	45	44	43
73				32	31	30	29	28	27
				16			13	12	11

A

RELEASE STATUS		RELEASE DATE
----------------	--	--------------

E	AVAILABLE	NOT APPLICABLE	34566-5143	0	C	BLUE	<table border="1"> <tr><td>72</td><td></td><td>70</td><td></td><td>68</td><td>67</td><td>66</td><td></td><td></td><td>63</td><td>62</td></tr> <tr><td>52</td><td>51</td><td></td><td></td><td>48</td><td>47</td><td>46</td><td></td><td>44</td><td></td><td>42</td></tr> <tr><td colspan="4">73</td><td>32</td><td></td><td>30</td><td></td><td></td><td></td><td>26</td></tr> <tr><td colspan="4"></td><td></td><td>15</td><td>14</td><td></td><td></td><td></td><td>10</td></tr> </table>	72		70		68	67	66			63	62	52	51			48	47	46		44		42	73				32		30				26						15	14				10
	72		70		68	67	66			63	62																																								
	52	51			48	47	46		44		42																																								
	73				32		30				26																																								
					15	14				10																																									
AVAILABLE	NOT APPLICABLE	34566-5153	0	A	BLACK	<table border="1"> <tr><td></td><td></td><td>70</td><td>69</td><td></td><td></td><td></td><td></td><td></td><td>63</td><td>62</td></tr> <tr><td>52</td><td>51</td><td></td><td>49</td><td></td><td>47</td><td></td><td></td><td>44</td><td>43</td><td>42</td></tr> <tr><td colspan="4">73</td><td>32</td><td></td><td></td><td>29</td><td>28</td><td>27</td><td>26</td></tr> <tr><td colspan="4"></td><td>16</td><td>15</td><td></td><td>13</td><td>12</td><td>11</td><td>10</td></tr> </table>			70	69						63	62	52	51		49		47			44	43	42	73				32			29	28	27	26					16	15		13	12	11	10	
		70	69						63	62																																									
52	51		49		47			44	43	42																																									
73				32			29	28	27	26																																									
				16	15		13	12	11	10																																									
AVAILABLE	NOT APPLICABLE	34566-5163	9	A	BLACK	<table border="1"> <tr><td>72</td><td></td><td></td><td>69</td><td></td><td>67</td><td></td><td>65</td><td></td><td>63</td><td></td></tr> <tr><td></td><td></td><td></td><td>49</td><td></td><td>47</td><td></td><td></td><td>44</td><td>43</td><td></td></tr> <tr><td colspan="4">73</td><td></td><td>31</td><td>30</td><td>29</td><td>28</td><td></td><td></td></tr> <tr><td colspan="4"></td><td>16</td><td>15</td><td>14</td><td></td><td></td><td>11</td><td>10</td></tr> </table>	72			69		67		65		63					49		47			44	43		73					31	30	29	28							16	15	14			11	10	
72			69		67		65		63																																										
			49		47			44	43																																										
73					31	30	29	28																																											
				16	15	14			11	10																																									
AVAILABLE	NOT APPLICABLE	34566-5173	9	B	ST.GRAY	<table border="1"> <tr><td></td><td></td><td></td><td></td><td>68</td><td>67</td><td></td><td></td><td>64</td><td>63</td><td></td></tr> <tr><td></td><td></td><td></td><td></td><td></td><td></td><td>46</td><td>45</td><td></td><td>43</td><td></td></tr> <tr><td colspan="4">73</td><td>32</td><td></td><td>30</td><td>29</td><td>28</td><td>27</td><td></td></tr> <tr><td colspan="4"></td><td></td><td></td><td></td><td></td><td></td><td></td><td>10</td></tr> </table>					68	67			64	63								46	45		43		73				32		30	29	28	27												10	
				68	67			64	63																																										
						46	45		43																																										
73				32		30	29	28	27																																										
										10																																									
D																																																			
C																																																			
B																																																			
A																																																			
<table border="1"> <tr> <td>RELEASE STATUS</td> <td></td> <td>RELEASE DATE</td> <td></td> <td></td> <td></td> <td></td> </tr> </table>							RELEASE STATUS		RELEASE DATE																																										
RELEASE STATUS		RELEASE DATE																																																	
19	18	17	16	15	14	13	12	11																																											





E

AVAILABLE	NOT APPLICABLE	34566-5343	0	B	ST.GRAY
-----------	----------------	------------	---	---	---------

				68	67			64	
						46	45		
73				32		30	29	28	27
								12	

D

AVAILABLE	NOT APPLICABLE	34566-5353	9	B	ST.GRAY
-----------	----------------	------------	---	---	---------

				68	67			64	63
						46	45	44	43
73				32		30	29	28	27
					15		13	12	

C

AVAILABLE	NOT APPLICABLE	34566-5363	0	C	BLUE
-----------	----------------	------------	---	---	------

72		70		68		66			63
52	51			48	47	46		44	
73				32		30			
					15	14			

B

AVAILABLE	NOT APPLICABLE	34566-5373	0	C	BLUE
-----------	----------------	------------	---	---	------

72		70		68		66			63
52	51			48	47	46		44	
73				32		30			
					15	14			

A

RELEASE STATUS		RELEASE DATE	
----------------	--	--------------	--



E

AVAILABLE	NOT APPLICABLE	34566-5543	9	A	BLACK
-----------	----------------	------------	---	---	-------

				68	67			64		
						46	45			
73				32		30	29	28	27	
								12		10

D

AVAILABLE	NOT APPLICABLE	34566-5553	9	B	ST.GRAY
-----------	----------------	------------	---	---	---------

				68	67			64		
						46	45			
73				32		30	29	28	27	
								12		10

C

AVAILABLE	NOT APPLICABLE	34566-5563	0	A	BLACK
-----------	----------------	------------	---	---	-------

72	71	70	69					64	63	
52	51		49	48	47		45	44	43	42
73				32		30		28		26
				16	15			12		10

B

AVAILABLE	NOT APPLICABLE	34566-5573	0	C	BLUE
-----------	----------------	------------	---	---	------

72		70		68		66			63	62
52	51		49	48	47	46		44		42
73				32		30				26
					15	14	13			10

A

RELEASE STATUS		RELEASE DATE	
----------------	--	--------------	--

E	AVAILABLE	NOT APPLICABLE	34566-5643	0	B	ST.GRAY	<table border="1"> <tr><td>72</td><td></td><td></td><td></td><td></td><td></td><td></td><td></td><td></td><td></td></tr> <tr><td>52</td><td></td><td></td><td></td><td>48</td><td></td><td>46</td><td></td><td></td><td>43</td></tr> <tr><td colspan="4">73</td><td></td><td></td><td>30</td><td></td><td></td><td></td></tr> <tr><td colspan="4"></td><td>16</td><td>15</td><td>14</td><td></td><td></td><td></td></tr> </table>	72										52				48		46			43	73						30								16	15	14			
	72																																														
	52				48		46			43																																					
	73						30																																								
				16	15	14																																									
D	AVAILABLE	NOT APPLICABLE	34566-5653	0	A	BLACK	<table border="1"> <tr><td>72</td><td>71</td><td>70</td><td>69</td><td>68</td><td></td><td>66</td><td>65</td><td>64</td><td>63</td></tr> <tr><td>52</td><td>51</td><td>50</td><td>49</td><td>48</td><td></td><td>46</td><td>45</td><td>44</td><td>43</td></tr> <tr><td colspan="4">73</td><td>32</td><td>31</td><td>30</td><td>29</td><td>28</td><td></td></tr> <tr><td colspan="4"></td><td></td><td>15</td><td>14</td><td>13</td><td>12</td><td></td></tr> </table>	72	71	70	69	68		66	65	64	63	52	51	50	49	48		46	45	44	43	73				32	31	30	29	28							15	14	13	12	
	72	71	70	69	68		66	65	64	63																																					
	52	51	50	49	48		46	45	44	43																																					
	73				32	31	30	29	28																																						
					15	14	13	12																																							
C	AVAILABLE	NOT APPLICABLE	34566-5663	0	C	BLUE	<table border="1"> <tr><td></td><td></td><td></td><td>69</td><td></td><td>67</td><td>66</td><td></td><td>64</td><td></td></tr> <tr><td>52</td><td>51</td><td>50</td><td></td><td>48</td><td></td><td>46</td><td>45</td><td>44</td><td></td></tr> <tr><td colspan="4">73</td><td>32</td><td>31</td><td></td><td></td><td>28</td><td>27</td></tr> <tr><td colspan="4"></td><td>16</td><td>15</td><td>14</td><td>13</td><td>12</td><td>11</td></tr> </table>				69		67	66		64		52	51	50		48		46	45	44		73				32	31			28	27					16	15	14	13	12	11
				69		67	66		64																																						
	52	51	50		48		46	45	44																																						
	73				32	31			28	27																																					
				16	15	14	13	12	11																																						
B	AVAILABLE	NOT APPLICABLE	34566-5673	0	C	BLUE	<table border="1"> <tr><td></td><td></td><td></td><td>69</td><td></td><td>67</td><td>66</td><td></td><td>64</td><td></td></tr> <tr><td>52</td><td>51</td><td>50</td><td>49</td><td>48</td><td></td><td>46</td><td>45</td><td>44</td><td></td></tr> <tr><td colspan="4">73</td><td>32</td><td>31</td><td></td><td></td><td>28</td><td>27</td></tr> <tr><td colspan="4"></td><td>16</td><td>15</td><td>14</td><td>13</td><td>12</td><td>11</td></tr> </table>				69		67	66		64		52	51	50	49	48		46	45	44		73				32	31			28	27					16	15	14	13	12	11
				69		67	66		64																																						
	52	51	50	49	48		46	45	44																																						
	73				32	31			28	27																																					
				16	15	14	13	12	11																																						

A										

RELEASE STATUS		RELEASE DATE								
19		18		17		16		15		14
										13
										12
										11

E

AVAILABLE	NOT APPLICABLE	34566-5743	0	A	BLACK
-----------	----------------	------------	---	---	-------

	71	70	69		67			64	63
52	51		49				45	44	43
73				32		30		28	
				16	15			12	

D

AVAILABLE	NOT APPLICABLE	34566-5753	0	A	BLACK
-----------	----------------	------------	---	---	-------

	71	70	69					64	63
52	51		49				45	44	43
73				32		30		28	
				16	15			12	

C

AVAILABLE	NOT APPLICABLE	34566-5763	0	C	BLUE
-----------	----------------	------------	---	---	------

72		70		68		66			63
52	51			48	47	46		44	
73				32		30			27
					15	14	13		

B

AVAILABLE	NOT APPLICABLE	34566-5773	0	C	BLUE
-----------	----------------	------------	---	---	------

72		70		68					63
52	51			48	47			44	
73				32		30			27
					15	14	13		

A

RELEASE STATUS		RELEASE DATE
----------------	--	--------------

E

AVAILABLE	NOT APPLICABLE	34566-5843	0	H	ST.GRAY
-----------	----------------	------------	---	---	---------

	79					74	73	72	71	
	59		57			54		52		
		38				34	33			
		18			15	14				11

D

AVAILABLE	NOT APPLICABLE	34566-5853	0	H	ST.GRAY
-----------	----------------	------------	---	---	---------

	79					74	73	72	71	
	59		57			54		52		
		38					33			
		18			15	14				11

C

AVAILABLE	NOT APPLICABLE	34566-5863	0	C	BLUE
-----------	----------------	------------	---	---	------

72		70				66			63	6
52	51					46		44		4
		73			32	30				2
						15	14			1

B

AVAILABLE	NOT APPLICABLE	34566-5873	0	B	ST.GRAY
-----------	----------------	------------	---	---	---------

72										6
52				48	47	46		44	43	
		73				30				
				16	15	14				

A

RELEASE STATUS		RELEASE DATE	
----------------	--	--------------	--

E	AVAILABLE	NOT APPLICABLE	34566-5953	0	A	BLACK	<table border="1"> <tr><td></td><td>71</td><td>70</td><td>69</td><td></td><td></td><td></td><td>65</td><td>64</td><td>63</td></tr> <tr><td>52</td><td>51</td><td></td><td>49</td><td>48</td><td>47</td><td></td><td>45</td><td>44</td><td>43</td></tr> <tr><td colspan="4">73</td><td>32</td><td></td><td>30</td><td>29</td><td>28</td><td>27</td></tr> <tr><td colspan="4"></td><td>16</td><td>15</td><td></td><td>13</td><td>12</td><td>11</td></tr> </table>		71	70	69				65	64	63	52	51		49	48	47		45	44	43	73				32		30	29	28	27					16	15		13	12	11
		71	70	69				65	64	63																																					
	52	51		49	48	47		45	44	43																																					
	73				32		30	29	28	27																																					
				16	15		13	12	11																																						
D	AVAILABLE	NOT APPLICABLE	34566-5963	0	B	ST.GRAY	<table border="1"> <tr><td>72</td><td>71</td><td>70</td><td></td><td>68</td><td>67</td><td>66</td><td></td><td></td><td></td></tr> <tr><td>52</td><td>51</td><td>50</td><td></td><td>48</td><td>47</td><td>46</td><td></td><td></td><td></td></tr> <tr><td colspan="4">73</td><td>32</td><td>31</td><td>30</td><td>29</td><td>28</td><td>27</td></tr> <tr><td colspan="4"></td><td>16</td><td>15</td><td>14</td><td>13</td><td></td><td></td></tr> </table>	72	71	70		68	67	66				52	51	50		48	47	46				73				32	31	30	29	28	27					16	15	14	13		
	72	71	70		68	67	66																																								
	52	51	50		48	47	46																																								
	73				32	31	30	29	28	27																																					
				16	15	14	13																																								
C	AVAILABLE	NOT APPLICABLE	34566-5973	0	C	BLUE	<table border="1"> <tr><td>72</td><td></td><td>70</td><td></td><td>68</td><td>67</td><td>66</td><td></td><td></td><td>63</td></tr> <tr><td>52</td><td>51</td><td></td><td></td><td>48</td><td>47</td><td>46</td><td></td><td>44</td><td></td></tr> <tr><td colspan="4">73</td><td>32</td><td></td><td>30</td><td></td><td></td><td>27</td></tr> <tr><td colspan="4"></td><td></td><td>15</td><td>14</td><td></td><td></td><td></td></tr> </table>	72		70		68	67	66			63	52	51			48	47	46		44		73				32		30			27						15	14			
	72		70		68	67	66			63																																					
	52	51			48	47	46		44																																						
	73				32		30			27																																					
					15	14																																									
B	AVAILABLE	NOT APPLICABLE	34566-5983	0	C	BLUE	<table border="1"> <tr><td></td><td></td><td></td><td>69</td><td></td><td>67</td><td>66</td><td></td><td>64</td><td></td></tr> <tr><td>52</td><td>51</td><td>50</td><td></td><td>48</td><td></td><td>46</td><td>45</td><td>44</td><td></td></tr> <tr><td colspan="4">73</td><td>32</td><td></td><td></td><td></td><td>28</td><td>27</td></tr> <tr><td colspan="4"></td><td>16</td><td>15</td><td>14</td><td>13</td><td>12</td><td>11</td></tr> </table>				69		67	66		64		52	51	50		48		46	45	44		73				32				28	27					16	15	14	13	12	11
				69		67	66		64																																						
	52	51	50		48		46	45	44																																						
	73				32				28	27																																					
				16	15	14	13	12	11																																						

A										

RELEASE STATUS		RELEASE DATE								
19		18		17		16		15		14
										13
										12
										11











E

AVAILABLE	NOT APPLICABLE	34566-6483	9	A	BLACK
-----------	----------------	------------	---	---	-------

72	71	70	69	68		66	65	64	63
52	51	50	49	48		46	45	44	43
73				32	31	30	29	28	
				15	14	13	12		

D

AVAILABLE	NOT APPLICABLE	34566-6493	9	B	ST.GRAY
-----------	----------------	------------	---	---	---------

72		70							
52				48	47	46			43
73						30			
				16	15	14			

C

AVAILABLE	NOT APPLICABLE	34566-6513	0	B	ST.GRAY
-----------	----------------	------------	---	---	---------

72				68	67				
52						46			43
73									
				16	15	14			

B

AVAILABLE	NOT APPLICABLE	34566-6523	0	B	ST.GRAY
-----------	----------------	------------	---	---	---------

				68	67			64	
						46	45		
73				32		30	29	28	27
					15		13		11

A

RELEASE STATUS		RELEASE DATE	
----------------	--	--------------	--

FORMAT: master-ib-prod-0  
 REVISION: 10  
 DATE: 2015/12/14

E

AVAILABLE	NOT APPLICABLE	34566-6583	9	A	BLACK
-----------	----------------	------------	---	---	-------

		70	69						
52	51	50	49						44
73				32			29	28	
				16	15	14	13	12	

D

AVAILABLE	NOT APPLICABLE	34566-6593	0	C	BLUE
-----------	----------------	------------	---	---	------

			69		67				64
52	51	50		48		46	45	44	
73				32				28	
				16	15	14	13	12	

C

AVAILABLE	NOT APPLICABLE	34566-6613	0	A	BLACK
-----------	----------------	------------	---	---	-------

72	71	70	69			66		64	
52	51	50	49			46	45	44	
73				32	31	30	29	28	
				16	15	14	13	12	

B

AVAILABLE	NOT APPLICABLE	34566-6623	9	B	ST.GRAY
-----------	----------------	------------	---	---	---------

				68	67				64
						46	45		
73				32		30	29	28	
					15		13		

A

RELEASE STATUS		RELEASE DATE	
----------------	--	--------------	--

E	AVAILABLE	NOT APPLICABLE	34566-6683	9	A	BLACK	<table border="1"> <tr><td>72</td><td></td><td>70</td><td></td><td></td><td>67</td><td></td><td></td><td></td><td>63</td><td></td></tr> <tr><td>52</td><td></td><td></td><td></td><td>48</td><td>47</td><td>46</td><td></td><td></td><td>43</td><td>42</td></tr> <tr><td colspan="4">73</td><td>32</td><td>31</td><td>30</td><td>29</td><td>28</td><td>27</td><td></td></tr> <tr><td colspan="4"></td><td>16</td><td>15</td><td>14</td><td>13</td><td>12</td><td>11</td><td></td></tr> </table>	72		70			67				63		52				48	47	46			43	42	73				32	31	30	29	28	27						16	15	14	13	12	11	
	72		70			67				63																																									
	52				48	47	46			43	42																																								
	73				32	31	30	29	28	27																																									
				16	15	14	13	12	11																																										
D	AVAILABLE	NOT APPLICABLE	34566-6693	9	C	BLUE	<table border="1"> <tr><td>72</td><td>71</td><td>70</td><td>69</td><td></td><td>67</td><td>66</td><td>65</td><td>64</td><td></td><td></td></tr> <tr><td>52</td><td>51</td><td>50</td><td>49</td><td></td><td>47</td><td>46</td><td>45</td><td>44</td><td></td><td></td></tr> <tr><td colspan="4">73</td><td></td><td>31</td><td>30</td><td>29</td><td>28</td><td></td><td>26</td></tr> <tr><td colspan="4"></td><td>16</td><td>15</td><td>14</td><td>13</td><td>12</td><td></td><td></td></tr> </table>	72	71	70	69		67	66	65	64			52	51	50	49		47	46	45	44			73					31	30	29	28		26					16	15	14	13	12		
	72	71	70	69		67	66	65	64																																										
	52	51	50	49		47	46	45	44																																										
	73					31	30	29	28		26																																								
				16	15	14	13	12																																											
C	AVAILABLE	NOT APPLICABLE	34822-0063	9	A	BLACK	<table border="1"> <tr><td></td><td>63</td><td>62</td><td>61</td><td>60</td><td>59</td><td></td><td></td><td></td><td></td><td>54</td></tr> <tr><td></td><td>47</td><td></td><td></td><td></td><td></td><td></td><td></td><td></td><td></td><td>38</td></tr> <tr><td colspan="4">65</td><td></td><td></td><td></td><td></td><td>28</td><td></td><td></td></tr> <tr><td colspan="4"></td><td></td><td>15</td><td>14</td><td>13</td><td></td><td></td><td></td></tr> </table>		63	62	61	60	59					54		47									38	65								28								15	14	13			
		63	62	61	60	59					54																																								
		47									38																																								
	65								28																																										
					15	14	13																																												
A	AVAILABLE	NOT APPLICABLE	34566-6713	9	A	BLACK	<table border="1"> <tr><td>72</td><td>71</td><td>70</td><td>69</td><td>68</td><td></td><td>66</td><td>65</td><td>64</td><td>63</td><td></td></tr> <tr><td>52</td><td>51</td><td>50</td><td>49</td><td>48</td><td></td><td>46</td><td>45</td><td>44</td><td>43</td><td>42</td></tr> <tr><td colspan="4">73</td><td>32</td><td>31</td><td>30</td><td>29</td><td>28</td><td></td><td>26</td></tr> <tr><td colspan="4"></td><td></td><td>15</td><td>14</td><td>13</td><td>12</td><td></td><td></td></tr> </table>	72	71	70	69	68		66	65	64	63		52	51	50	49	48		46	45	44	43	42	73				32	31	30	29	28		26						15	14	13	12		
	72	71	70	69	68		66	65	64	63																																									
	52	51	50	49	48		46	45	44	43	42																																								
	73				32	31	30	29	28		26																																								
					15	14	13	12																																											

RELEASE STATUS		RELEASE DATE	
----------------	--	--------------	--





E	AVAILABLE	NOT APPLICABLE	34566-6873	9	B	ST.GRAY	<table border="1"> <tr> <td>72</td><td></td><td></td><td></td><td>68</td><td>67</td><td></td><td></td> </tr> <tr> <td>52</td><td></td><td></td><td></td><td>48</td><td>47</td><td>46</td><td></td> </tr> <tr> <td colspan="4">73</td> <td></td><td></td><td>30</td><td></td> </tr> <tr> <td colspan="4"></td> <td>16</td><td>15</td><td>14</td><td></td> </tr> </table>	72				68	67			52				48	47	46		73						30						16	15	14	
	72				68	67																																	
	52				48	47	46																																
	73						30																																
				16	15	14																																	
D	AVAILABLE	NOT APPLICABLE	34566-6883	9	A	BLACK	<table border="1"> <tr> <td>72</td><td></td><td>70</td><td></td><td></td><td>67</td><td></td><td></td> </tr> <tr> <td>52</td><td>51</td><td></td><td></td><td>48</td><td>47</td><td>46</td><td></td> </tr> <tr> <td colspan="4">73</td> <td></td><td></td><td></td><td></td> </tr> <tr> <td colspan="4"></td> <td></td><td></td><td></td><td></td> </tr> </table>	72		70			67			52	51			48	47	46		73															
	72		70			67																																	
	52	51			48	47	46																																
	73																																						
C	AVAILABLE	NOT APPLICABLE	34566-6893	0	B	ST.GRAY	<table border="1"> <tr> <td>72</td><td>71</td><td>70</td><td>69</td><td>68</td><td>67</td><td>66</td><td>65</td> </tr> <tr> <td>52</td><td>51</td><td>50</td><td>49</td><td>48</td><td>47</td><td>46</td><td>45</td> </tr> <tr> <td colspan="4">73</td> <td>32</td><td>31</td><td>30</td><td>29</td> </tr> <tr> <td colspan="4"></td> <td>16</td><td>15</td><td>14</td><td>13</td> </tr> </table>	72	71	70	69	68	67	66	65	52	51	50	49	48	47	46	45	73				32	31	30	29					16	15	14	13
	72	71	70	69	68	67	66	65																															
	52	51	50	49	48	47	46	45																															
	73				32	31	30	29																															
				16	15	14	13																																
B	AVAILABLE	NOT APPLICABLE	34566-6913	9	A	BLACK	<table border="1"> <tr> <td>72</td><td>71</td><td>70</td><td>69</td><td>68</td><td>67</td><td>66</td><td>65</td> </tr> <tr> <td>52</td><td>51</td><td>50</td><td>49</td><td>48</td><td>47</td><td>46</td><td>45</td> </tr> <tr> <td colspan="4">73</td> <td>32</td><td>31</td><td>30</td><td>29</td> </tr> <tr> <td colspan="4"></td> <td>16</td><td>15</td><td>14</td><td>13</td> </tr> </table>	72	71	70	69	68	67	66	65	52	51	50	49	48	47	46	45	73				32	31	30	29					16	15	14	13
	72	71	70	69	68	67	66	65																															
	52	51	50	49	48	47	46	45																															
	73				32	31	30	29																															
				16	15	14	13																																

A																	

RELEASE STATUS		RELEASE DATE	
----------------	--	--------------	--

E	AVAILABLE	NOT APPLICABLE	34566-6973	0	C	BLUE	<table border="1"> <tr><td></td><td></td><td></td><td></td><td></td><td></td><td></td><td></td><td></td></tr> <tr><td></td><td>71</td><td>70</td><td>69</td><td></td><td>67</td><td></td><td>65</td><td>64</td></tr> <tr><td>52</td><td>51</td><td>50</td><td>49</td><td>48</td><td>47</td><td>46</td><td>45</td><td>44</td></tr> <tr><td colspan="4">73</td><td>32</td><td></td><td></td><td></td><td>28</td></tr> <tr><td colspan="4"></td><td>16</td><td>15</td><td>14</td><td>13</td><td>12</td></tr> </table>											71	70	69		67		65	64	52	51	50	49	48	47	46	45	44	73				32				28					16	15	14	13	12
		71	70	69		67		65	64																																											
	52	51	50	49	48	47	46	45	44																																											
73				32				28																																												
				16	15	14	13	12																																												
D	AVAILABLE	NOT APPLICABLE	34566-6983	0	C	BLUE	<table border="1"> <tr><td></td><td>71</td><td></td><td>69</td><td></td><td>67</td><td></td><td>65</td><td>64</td></tr> <tr><td>52</td><td>51</td><td>50</td><td></td><td>48</td><td>47</td><td>46</td><td>45</td><td>44</td></tr> <tr><td colspan="4">73</td><td></td><td></td><td></td><td></td><td>28</td></tr> <tr><td colspan="4"></td><td>16</td><td>15</td><td>14</td><td>13</td><td>12</td></tr> </table>		71		69		67		65	64	52	51	50		48	47	46	45	44	73								28					16	15	14	13	12									
		71		69		67		65	64																																											
52	51	50		48	47	46	45	44																																												
73								28																																												
				16	15	14	13	12																																												
C	AVAILABLE	NOT APPLICABLE	34566-6993	0	G	BLUE	<table border="1"> <tr><td></td><td></td><td>78</td><td>77</td><td>76</td><td></td><td></td><td></td><td></td></tr> <tr><td></td><td></td><td></td><td></td><td></td><td></td><td></td><td></td><td></td></tr> <tr><td>40</td><td>39</td><td>38</td><td>37</td><td>36</td><td>35</td><td>34</td><td>33</td><td>32</td></tr> <tr><td>20</td><td>19</td><td>18</td><td>17</td><td>16</td><td>15</td><td>14</td><td>13</td><td>12</td></tr> </table>			78	77	76														40	39	38	37	36	35	34	33	32	20	19	18	17	16	15	14	13	12									
			78	77	76																																															
40	39	38	37	36	35	34	33	32																																												
20	19	18	17	16	15	14	13	12																																												
A	AVAILABLE	NOT APPLICABLE	34566-7013	9	A	BLACK	<table border="1"> <tr><td></td><td>71</td><td>70</td><td>69</td><td></td><td></td><td></td><td></td><td>64</td></tr> <tr><td>52</td><td>51</td><td>50</td><td>49</td><td></td><td></td><td></td><td>45</td><td>44</td></tr> <tr><td colspan="4">73</td><td>32</td><td></td><td></td><td>29</td><td>28</td></tr> <tr><td colspan="4"></td><td>16</td><td>15</td><td>14</td><td>13</td><td>12</td></tr> </table>		71	70	69					64	52	51	50	49				45	44	73				32			29	28					16	15	14	13	12									
	71	70	69					64																																												
52	51	50	49				45	44																																												
73				32			29	28																																												
				16	15	14	13	12																																												
B																																																				
<table border="1"> <tr> <td>RELEASE STATUS</td> <td></td> <td>RELEASE DATE</td> <td></td> <td></td> <td></td> <td></td> <td></td> <td></td> </tr> <tr> <td>19</td> <td>18</td> <td>17</td> <td>16</td> <td>15</td> <td>14</td> <td>13</td> <td>12</td> <td>11</td> </tr> </table>									RELEASE STATUS		RELEASE DATE							19	18	17	16	15	14	13	12	11																										
RELEASE STATUS		RELEASE DATE																																																		
19	18	17	16	15	14	13	12	11																																												

E	AVAILABLE	APPLICABLE	34566-7073	9	F	NATURAL	73	32	15	14	13					
	AVAILABLE	NOT APPLICABLE	34566-7073	9	F	NATURAL	73	69	68	30						
	AVAILABLE	NOT APPLICABLE	34566-7083	9	B	ST.GRAY	73									
	AVAILABLE	NOT APPLICABLE	34566-7093	9	B	ST.GRAY	73	72	71	70	69	68	67	66	65	64
	AVAILABLE	NOT APPLICABLE	34566-7093	9	B	ST.GRAY	73	52	51	50	49	48	47	46	45	44
D	AVAILABLE	NOT APPLICABLE	34566-7113	9	G	BLUE	73	80	79	78	76	54	33			
	AVAILABLE	NOT APPLICABLE	34566-7113	9	G	BLUE	73	60	59	58	57	37				
	AVAILABLE	NOT APPLICABLE	34566-7113	9	G	BLUE	73	40	39	37						
	AVAILABLE	NOT APPLICABLE	34566-7113	9	G	BLUE	73	20	19	18						
C	AVAILABLE	NOT APPLICABLE	34566-7113	9	G	BLUE	73									
	AVAILABLE	NOT APPLICABLE	34566-7113	9	G	BLUE	73									
B	AVAILABLE	NOT APPLICABLE	34566-7113	9	G	BLUE	73									
	AVAILABLE	NOT APPLICABLE	34566-7113	9	G	BLUE	73									
A	AVAILABLE	NOT APPLICABLE	34566-7113	9	G	BLUE	73									
	AVAILABLE	NOT APPLICABLE	34566-7113	9	G	BLUE	73									
RELEASE STATUS		RELEASE DATE		19	18	17	16	15	14	13	12	11				

E	AVAILABLE	APPLICABLE	34566-7163	0	A	BLACK	73	16	15			29	28	
	AVAILABLE	NOT APPLICABLE	34566-7173	0	B	ST.GRAY	73	32		30	29	28	27	
	AVAILABLE	NOT APPLICABLE	34566-7183	0	B	ST.GRAY	73	32	31	30	29	28	27	26
	AVAILABLE	NOT APPLICABLE	34566-7193	0	A	BLACK	73	32			29	28	27	26
D	AVAILABLE	NOT APPLICABLE	34566-7183	0	B	ST.GRAY	73	16	15	14	13	12		
	AVAILABLE	NOT APPLICABLE	34566-7193	0	A	BLACK	73	16	15		13	12		
C	AVAILABLE	NOT APPLICABLE	34566-7213	0	A	BLACK	73	32				28	27	
	AVAILABLE	NOT APPLICABLE	34566-7213	0	A	BLACK	73	16				12		

B	AVAILABLE	NOT APPLICABLE	34566-7213	0	A	BLACK	73	32				28	27	
	AVAILABLE	NOT APPLICABLE	34566-7213	0	A	BLACK	73	16				12		

A	RELEASE STATUS		RELEASE DATE											
	19	18	17	16	15	14	13	12	11					



E	AVAILABLE	NOT APPLICABLE	34566-7353	9	C	BLUE	<table border="1"> <tr><td></td><td></td><td></td><td>69</td><td></td><td>67</td><td>66</td><td></td><td>64</td><td></td><td>62</td><td></td></tr> <tr><td>52</td><td>51</td><td>50</td><td></td><td>48</td><td>47</td><td>46</td><td>45</td><td>44</td><td></td><td>42</td><td></td></tr> <tr><td colspan="4">73</td><td>32</td><td></td><td></td><td></td><td>28</td><td>27</td><td>26</td><td></td></tr> <tr><td colspan="4"></td><td>16</td><td>15</td><td>14</td><td>13</td><td>12</td><td>11</td><td>10</td><td>9</td></tr> </table>				69		67	66		64		62		52	51	50		48	47	46	45	44		42		73				32				28	27	26						16	15	14	13	12	11	10	9
				69		67	66		64		62																																												
	52	51	50		48	47	46	45	44		42																																												
	73				32				28	27	26																																												
				16	15	14	13	12	11	10	9																																												
D	AVAILABLE	NOT APPLICABLE	34566-7363	0	B	ST.GRAY	<table border="1"> <tr><td>72</td><td></td><td>70</td><td></td><td>68</td><td></td><td></td><td></td><td></td><td></td><td>62</td><td>61</td></tr> <tr><td>52</td><td></td><td></td><td></td><td></td><td></td><td>46</td><td></td><td>44</td><td>43</td><td></td><td>41</td></tr> <tr><td colspan="4">73</td><td></td><td></td><td></td><td></td><td></td><td></td><td></td><td></td></tr> <tr><td colspan="4"></td><td>16</td><td>15</td><td>14</td><td></td><td></td><td></td><td></td><td></td></tr> </table>	72		70		68						62	61	52						46		44	43		41	73																16	15	14					
	72		70		68						62	61																																											
	52						46		44	43		41																																											
73																																																							
				16	15	14																																																	
C	AVAILABLE	NOT APPLICABLE	34566-7373	0	A	BLACK	<table border="1"> <tr><td>72</td><td>71</td><td>70</td><td>69</td><td>68</td><td></td><td>66</td><td>65</td><td>64</td><td></td><td></td><td>61</td></tr> <tr><td>52</td><td>51</td><td>50</td><td>49</td><td>48</td><td></td><td>46</td><td>45</td><td>44</td><td>43</td><td>42</td><td></td></tr> <tr><td colspan="4">73</td><td></td><td>31</td><td>30</td><td>29</td><td>28</td><td></td><td>26</td><td>25</td></tr> <tr><td colspan="4"></td><td></td><td>15</td><td>14</td><td>13</td><td>12</td><td></td><td></td><td>9</td></tr> </table>	72	71	70	69	68		66	65	64			61	52	51	50	49	48		46	45	44	43	42		73					31	30	29	28		26	25						15	14	13	12			9
	72	71	70	69	68		66	65	64			61																																											
52	51	50	49	48		46	45	44	43	42																																													
73					31	30	29	28		26	25																																												
					15	14	13	12			9																																												
A	AVAILABLE	NOT APPLICABLE	34566-7383	0	C	BLUE	<table border="1"> <tr><td></td><td>71</td><td>70</td><td></td><td></td><td>67</td><td>66</td><td>65</td><td>64</td><td></td><td></td><td>61</td></tr> <tr><td>52</td><td>51</td><td>50</td><td>49</td><td>48</td><td>47</td><td></td><td>45</td><td>44</td><td></td><td></td><td>41</td></tr> <tr><td colspan="4">73</td><td>32</td><td></td><td></td><td></td><td>28</td><td>27</td><td></td><td>25</td></tr> <tr><td colspan="4"></td><td>16</td><td>15</td><td>14</td><td>13</td><td>12</td><td>11</td><td>10</td><td>9</td></tr> </table>		71	70			67	66	65	64			61	52	51	50	49	48	47		45	44			41	73				32				28	27		25					16	15	14	13	12	11	10	9
	71	70			67	66	65	64			61																																												
52	51	50	49	48	47		45	44			41																																												
73				32				28	27		25																																												
				16	15	14	13	12	11	10	9																																												

RELEASE STATUS		RELEASE DATE	
----------------	--	--------------	--

E

AVAILABLE	NOT APPLICABLE	34566-7453	0	C	BLUE
-----------	----------------	------------	---	---	------

	71	70			67	66	65	64	
52	51	50	49	48	47		45	44	
73				32				28	27
				16	15	14	13	12	11

D

AVAILABLE	NOT APPLICABLE	34566-7463	0	B	ST.GRAY
-----------	----------------	------------	---	---	---------

72				68					
52				48	47	46			43
73						30			
				16	15	14			

C

AVAILABLE	NOT APPLICABLE	34566-7473	0	B	ST.GRAY
-----------	----------------	------------	---	---	---------

72				68	67				63
52				48	47	46			43
73						30			27
				16		14			11

B

AVAILABLE	NOT APPLICABLE	34566-7483	0	B	ST.GRAY
-----------	----------------	------------	---	---	---------

72				68					
52				48	47	46			43
73						30			
				16	15	14			

A

RELEASE STATUS		RELEASE DATE
----------------	--	--------------

E	AVAILABLE	NOT APPLICABLE	34566-7553 SAME AS P/N 35466-1983	0	B	ST.GRAY	<table border="1"> <tr><td></td><td></td><td></td><td></td><td></td><td></td><td></td><td></td><td></td><td></td><td></td><td></td></tr> <tr><td></td><td></td><td></td><td></td><td></td><td></td><td></td><td></td><td></td><td></td><td></td><td></td></tr> <tr><td colspan="4">73</td><td></td><td></td><td></td><td></td><td></td><td></td><td></td><td></td></tr> </table>																																		73																														
73																																																																							
AVAILABLE	NOT APPLICABLE	34566-7563	0	C	BLUE	<table border="1"> <tr><td></td><td></td><td></td><td></td><td></td><td></td><td></td><td></td><td></td><td></td><td></td><td></td></tr> <tr><td></td><td></td><td></td><td></td><td></td><td></td><td></td><td></td><td></td><td></td><td></td><td></td></tr> <tr><td colspan="4">73</td><td></td><td></td><td></td><td></td><td></td><td></td><td></td><td></td></tr> </table>																																		73																															
73																																																																							
D	AVAILABLE	NOT APPLICABLE	34566-7573	0	B	ST.GRAY	<table border="1"> <tr><td>72</td><td></td><td>70</td><td></td><td>68</td><td></td><td></td><td></td><td></td><td></td><td></td><td></td></tr> <tr><td>52</td><td></td><td></td><td></td><td>48</td><td>47</td><td>46</td><td></td><td></td><td></td><td></td><td>43</td></tr> <tr><td colspan="4">73</td><td></td><td></td><td>30</td><td></td><td></td><td></td><td></td><td></td></tr> <tr><td colspan="4"></td><td>16</td><td>15</td><td>14</td><td></td><td></td><td></td><td></td><td></td></tr> </table>										72		70		68								52				48	47	46					43	73						30										16	15	14												
	72		70		68																																																																		
52				48	47	46					43																																																												
73						30																																																																	
				16	15	14																																																																	
C	AVAILABLE	NOT APPLICABLE	34566-7583	9	A	BLACK	<table border="1"> <tr><td>72</td><td></td><td>70</td><td></td><td></td><td>67</td><td></td><td></td><td></td><td></td><td></td><td>63</td></tr> <tr><td>52</td><td></td><td></td><td></td><td>48</td><td>47</td><td>46</td><td></td><td></td><td></td><td></td><td>43</td></tr> <tr><td colspan="4">73</td><td>32</td><td>31</td><td>30</td><td>29</td><td>28</td><td>27</td><td></td><td></td></tr> <tr><td colspan="4"></td><td>16</td><td>15</td><td>14</td><td>13</td><td>12</td><td>11</td><td></td><td></td></tr> </table>										72		70			67						63	52				48	47	46					43	73				32	31	30	29	28	27							16	15	14	13	12	11									
72		70			67						63																																																												
52				48	47	46					43																																																												
73				32	31	30	29	28	27																																																														
				16	15	14	13	12	11																																																														
B																																																																							
A																																																																							
<table border="1"> <tr> <td>RELEASE STATUS</td> <td></td> <td>RELEASE DATE</td> <td></td> <td></td> <td></td> <td></td> <td></td> <td></td> <td></td> <td></td> <td></td> </tr> <tr> <td>19</td> <td></td> <td>18</td> <td></td> <td>17</td> <td></td> <td>16</td> <td></td> <td>15</td> <td></td> <td>14</td> <td></td> </tr> <tr> <td></td> <td></td> <td></td> <td></td> <td></td> <td></td> <td></td> <td></td> <td></td> <td></td> <td>13</td> <td></td> </tr> <tr> <td></td> <td></td> <td></td> <td></td> <td></td> <td></td> <td></td> <td></td> <td></td> <td></td> <td>12</td> <td></td> </tr> <tr> <td></td> <td></td> <td></td> <td></td> <td></td> <td></td> <td></td> <td></td> <td></td> <td></td> <td>11</td> <td></td> </tr> </table>												RELEASE STATUS		RELEASE DATE										19		18		17		16		15		14												13												12												11	
RELEASE STATUS		RELEASE DATE																																																																					
19		18		17		16		15		14																																																													
										13																																																													
										12																																																													
										11																																																													



E

AVAILABLE	NOT APPLICABLE	34566-7613	9	H	ST.GRAY
-----------	----------------	------------	---	---	---------

80	79	78			75			
60	59		57			54		
40	39		37	36		34	33	32
20		18					13	12

D

AVAILABLE	NOT APPLICABLE	34566-7623	9	G	BLUE
-----------	----------------	------------	---	---	------

80	79	78			75			
60	59	58	57			54		
40	39		37	36		34	33	32
20	19	18					13	12

C

AVAILABLE	NOT APPLICABLE	34822-0133	0	C	BLUE
-----------	----------------	------------	---	---	------

64	63	62	61	60				
48	47	46	45			42		
65					31			
				16				

A

AVAILABLE	NOT APPLICABLE	34566-7633	9	A	BLACK
-----------	----------------	------------	---	---	-------

72	71	70	69	68	67	66	65	64
52	51	50	49	48	47	46	45	44
73				32	31	30	29	28
				16	15	14	13	12

B

RELEASE STATUS		RELEASE DATE	
----------------	--	--------------	--



E	AVAILABLE	APPLICABLE	34566-7773	0	B	ST.GRAY	73	16	14	27	11
	AVAILABLE	TBD	34822-0153	9	A	BLACK	63 62 61 60 59	47	65	28	15 14 13
D	AVAILABLE	NOT APPLICABLE	34566-7783	0	A	BLACK	72 71 70 69 68	52 51 50 49 48	73	32 31 30 29 28	15 14 13 12
	AVAILABLE	NOT APPLICABLE	34566-7793	0	A	BLACK	72 70 67 66 65	52 51 49 48 47 46 45	73	28 27	12 11
C	AVAILABLE	NOT APPLICABLE	34566-7813	0	A	BLACK	70 69 68 67	52 51 50 49	73	32 29 28 27	16 15 14 13 12 11
	AVAILABLE	NOT APPLICABLE	34566-7813	0	A	BLACK	70 69 68 67	52 51 50 49	73	32 29 28 27	16 15 14 13 12 11

B											
A											

RELEASE STATUS		RELEASE DATE									
19	18	17	16	15	14	13	12	11			

E	AVAILABLE	NOT APPLICABLE	34566-7863	9	C	BLUE	73	32	30	2							
								15	14								
	AVAILABLE	NOT APPLICABLE	34566-7873	9	A	BLACK	73	71	69	65	64	4					
								50		45		4					
									31	29	28						
D	AVAILABLE	NOT APPLICABLE	34566-7883	9	A	BLACK	73	72	68	67	66	65					
									48	47							
										31	30						
C	AVAILABLE	NOT APPLICABLE	34566-7893	9	A	BLACK	73	72	71	70	69	68	66	65	64	6	
									52	51	50	49	48	46	45	44	4
B	AVAILABLE	TBD	34822-0163	0	A	BLACK	65	64	63								

A																		
---	--	--	--	--	--	--	--	--	--	--	--	--	--	--	--	--	--	--

RELEASE STATUS		RELEASE DATE																
19		18		17		16		15		14		13		12		11		

E	AVAILABLE	NOT APPLICABLE	34566-7963	9	A	BLACK	<table border="1"> <tr><td>73</td><td>16</td><td>15</td><td>14</td><td></td><td></td><td></td><td></td><td></td><td></td><td></td><td></td><td></td><td></td><td></td><td></td><td></td><td></td><td></td><td></td></tr> <tr><td>72</td><td>71</td><td>70</td><td>69</td><td>68</td><td></td><td>66</td><td>65</td><td>64</td><td>63</td><td></td><td>61</td><td>60</td><td></td><td></td><td></td><td></td><td></td><td></td><td></td></tr> <tr><td>52</td><td>51</td><td>50</td><td>49</td><td>48</td><td></td><td>46</td><td>45</td><td>44</td><td>43</td><td>42</td><td></td><td>40</td><td></td><td></td><td></td><td></td><td></td><td></td><td></td></tr> <tr><td colspan="4">73</td><td>32</td><td>31</td><td>30</td><td>29</td><td>28</td><td></td><td>26</td><td>25</td><td></td><td></td><td></td><td></td><td></td><td></td><td></td><td></td></tr> <tr><td colspan="4"></td><td></td><td>15</td><td>14</td><td>13</td><td>12</td><td></td><td></td><td></td><td>9</td><td></td><td></td><td></td><td></td><td></td><td></td><td></td><td></td></tr> </table>	73	16	15	14																	72	71	70	69	68		66	65	64	63		61	60								52	51	50	49	48		46	45	44	43	42		40								73				32	31	30	29	28		26	25														15	14	13	12				9								
	73	16	15	14																																																																																																								
	72	71	70	69	68		66	65	64	63		61	60																																																																																															
	52	51	50	49	48		46	45	44	43	42		40																																																																																															
73				32	31	30	29	28		26	25																																																																																																	
					15	14	13	12				9																																																																																																
D	AVAILABLE	NOT APPLICABLE	34566-7973	9	B	ST.GRAY	<table border="1"> <tr><td>72</td><td></td><td></td><td></td><td></td><td></td><td></td><td></td><td></td><td></td><td></td><td>62</td><td>61</td><td>60</td><td></td><td></td><td></td><td></td><td></td><td></td></tr> <tr><td>52</td><td></td><td>50</td><td>49</td><td>48</td><td>47</td><td>46</td><td>45</td><td></td><td>43</td><td></td><td>41</td><td>40</td><td></td><td></td><td></td><td></td><td></td><td></td><td></td></tr> <tr><td colspan="4">73</td><td></td><td></td><td>30</td><td>29</td><td></td><td></td><td></td><td></td><td></td><td></td><td></td><td></td><td></td><td></td><td></td><td></td></tr> <tr><td colspan="4"></td><td>16</td><td>15</td><td>14</td><td></td><td></td><td></td><td></td><td></td><td></td><td></td><td></td><td></td><td></td><td></td><td></td><td></td><td></td></tr> </table>	72											62	61	60							52		50	49	48	47	46	45		43		41	40								73						30	29																	16	15	14																																		
	72											62	61	60																																																																																														
	52		50	49	48	47	46	45		43		41	40																																																																																															
73						30	29																																																																																																					
				16	15	14																																																																																																						
C	AVAILABLE	NOT APPLICABLE	34566-7983	9	B	ST.GRAY	<table border="1"> <tr><td>72</td><td></td><td></td><td></td><td></td><td></td><td></td><td></td><td></td><td></td><td></td><td>62</td><td>61</td><td>60</td><td></td><td></td><td></td><td></td><td></td><td></td></tr> <tr><td>52</td><td></td><td>50</td><td>49</td><td>48</td><td>47</td><td>46</td><td>45</td><td></td><td>43</td><td></td><td>41</td><td>40</td><td></td><td></td><td></td><td></td><td></td><td></td><td></td></tr> <tr><td colspan="4">73</td><td></td><td></td><td>30</td><td>29</td><td></td><td></td><td></td><td></td><td></td><td></td><td></td><td></td><td></td><td></td><td></td><td></td></tr> <tr><td colspan="4"></td><td>16</td><td>15</td><td>14</td><td></td><td></td><td></td><td></td><td></td><td></td><td></td><td></td><td></td><td></td><td></td><td></td><td></td><td></td></tr> </table>	72											62	61	60							52		50	49	48	47	46	45		43		41	40								73						30	29																	16	15	14																																		
	72											62	61	60																																																																																														
52		50	49	48	47	46	45		43		41	40																																																																																																
73						30	29																																																																																																					
				16	15	14																																																																																																						
A	AVAILABLE	NOT APPLICABLE	34566-7993	9	C	BLUE	<table border="1"> <tr><td></td><td></td><td>70</td><td>69</td><td></td><td>67</td><td>66</td><td></td><td>64</td><td></td><td></td><td></td><td>61</td><td>60</td><td></td><td></td><td></td><td></td><td></td><td></td><td></td></tr> <tr><td>52</td><td>51</td><td>50</td><td>49</td><td>48</td><td>47</td><td>46</td><td>45</td><td>44</td><td></td><td></td><td></td><td>41</td><td></td><td></td><td></td><td></td><td></td><td></td><td></td><td></td></tr> <tr><td colspan="4">73</td><td>32</td><td></td><td></td><td></td><td>28</td><td>27</td><td></td><td>25</td><td></td><td></td><td></td><td></td><td></td><td></td><td></td><td></td><td></td></tr> <tr><td colspan="4"></td><td>16</td><td>15</td><td>14</td><td>13</td><td>12</td><td>11</td><td>10</td><td>9</td><td>8</td><td></td><td></td><td></td><td></td><td></td><td></td><td></td><td></td><td></td></tr> </table>			70	69		67	66		64				61	60								52	51	50	49	48	47	46	45	44				41									73				32				28	27		25														16	15	14	13	12	11	10	9	8																									
		70	69		67	66		64				61	60																																																																																															
52	51	50	49	48	47	46	45	44				41																																																																																																
73				32				28	27		25																																																																																																	
				16	15	14	13	12	11	10	9	8																																																																																																

FORMAT: master-ib-prod-D  
 REVISION: 10  
 DATE: 2015/12/14

E	AVAILABLE	NOT APPLICABLE	34566-8053	9	A	BLACK	<table border="1"> <tr> <td>72</td> <td></td> <td></td> <td></td> <td>68</td> <td>67</td> <td>66</td> <td></td> <td></td> <td></td> </tr> <tr> <td></td> <td></td> <td></td> <td></td> <td></td> <td></td> <td>46</td> <td></td> <td></td> <td></td> </tr> <tr> <td colspan="4">73</td> <td></td> <td>31</td> <td></td> <td></td> <td></td> <td></td> </tr> </table>	72				68	67	66										46				73					31														
	72				68	67	66																																								
						46																																									
73					31																																										
D	AVAILABLE	NOT APPLICABLE	34566-8063	9	C	BLUE	<table border="1"> <tr> <td></td> <td>71</td> <td></td> <td>69</td> <td></td> <td></td> <td></td> <td>65</td> <td>64</td> <td></td> </tr> <tr> <td></td> <td></td> <td>50</td> <td></td> <td></td> <td></td> <td></td> <td>45</td> <td></td> <td>43</td> </tr> <tr> <td colspan="4">73</td> <td></td> <td>31</td> <td></td> <td>29</td> <td>28</td> <td></td> </tr> <tr> <td></td> <td></td> <td></td> <td></td> <td>16</td> <td></td> <td></td> <td></td> <td>12</td> <td>11</td> </tr> </table>		71		69				65	64				50					45		43	73					31		29	28						16				12	11
	71		69				65	64																																							
		50					45		43																																						
73					31		29	28																																							
				16				12	11																																						
C	AVAILABLE	NOT APPLICABLE	34566-8073	9	B	ST.GRAY	<table border="1"> <tr> <td></td> <td></td> <td></td> <td>69</td> <td></td> <td></td> <td></td> <td>65</td> <td>64</td> <td>63</td> </tr> <tr> <td></td> <td></td> <td></td> <td>49</td> <td></td> <td></td> <td></td> <td>45</td> <td>44</td> <td>43</td> </tr> <tr> <td colspan="4">73</td> <td></td> <td></td> <td></td> <td></td> <td></td> <td></td> </tr> <tr> <td></td> <td></td> <td></td> <td></td> <td></td> <td></td> <td></td> <td></td> <td>12</td> <td>11</td> </tr> </table>				69				65	64	63				49				45	44	43	73																		12	11
			69				65	64	63																																						
			49				45	44	43																																						
73																																															
								12	11																																						
B	AVAILABLE	NOT APPLICABLE	34566-8083	9	B	ST.GRAY	<table border="1"> <tr> <td></td> <td></td> <td></td> <td></td> <td></td> <td></td> <td></td> <td></td> <td></td> <td></td> </tr> <tr> <td colspan="4">73</td> <td></td> <td></td> <td></td> <td></td> <td></td> <td>27</td> </tr> </table>											73									27																				
73									27																																						
A	AVAILABLE	NOT APPLICABLE	34566-8093	9	A	BLACK	<table border="1"> <tr> <td></td> <td>71</td> <td></td> <td>69</td> <td>68</td> <td></td> <td>66</td> <td>65</td> <td>64</td> <td></td> </tr> <tr> <td></td> <td></td> <td>50</td> <td>49</td> <td></td> <td></td> <td></td> <td>45</td> <td>44</td> <td></td> </tr> <tr> <td colspan="4">73</td> <td>32</td> <td>31</td> <td>30</td> <td>29</td> <td></td> <td></td> </tr> <tr> <td></td> <td></td> <td></td> <td></td> <td>16</td> <td>15</td> <td>14</td> <td>13</td> <td></td> <td></td> </tr> </table>		71		69	68		66	65	64				50	49				45	44		73				32	31	30	29							16	15	14	13		
	71		69	68		66	65	64																																							
		50	49				45	44																																							
73				32	31	30	29																																								
				16	15	14	13																																								
	AVAILABLE	NOT APPLICABLE	34566-8113	9	C	BLUE	<table border="1"> <tr> <td></td> <td></td> <td></td> <td></td> <td>68</td> <td></td> <td></td> <td></td> <td></td> <td>63</td> </tr> <tr> <td></td> <td></td> <td></td> <td></td> <td>48</td> <td></td> <td></td> <td></td> <td></td> <td>43</td> </tr> <tr> <td colspan="4">73</td> <td>32</td> <td></td> <td></td> <td></td> <td></td> <td>27</td> </tr> <tr> <td></td> <td></td> <td></td> <td></td> <td></td> <td></td> <td></td> <td></td> <td></td> <td>11</td> </tr> </table>					68					63					48					43	73				32					27										11
				68					63																																						
				48					43																																						
73				32					27																																						
									11																																						

RELEASE STATUS		RELEASE DATE	
----------------	--	--------------	--

FORMAT: master-ib-prod-D  
 REVISION: 10  
 DATE: 2015/12/14







E	AVAILABLE	NOT APPLICABLE	34566-8383	9	A	BLACK	<table border="1"> <tr> <td>52</td><td>51</td><td></td><td></td><td></td><td></td><td></td><td>46</td><td>45</td> </tr> <tr> <td colspan="4">73</td> <td>32</td><td></td><td></td><td>30</td><td>29</td> </tr> <tr> <td colspan="4"></td> <td>16</td><td>15</td><td></td><td></td><td>13</td> </tr> </table>	52	51						46	45	73				32			30	29					16	15			13										
	52	51						46	45																																			
73				32			30	29																																				
				16	15			13																																				
D	AVAILABLE	NOT APPLICABLE	34566-8393	0	A	BLACK	<table border="1"> <tr> <td>72</td><td></td><td>70</td><td></td><td></td><td></td><td></td><td></td><td></td> </tr> <tr> <td>52</td><td>51</td><td></td><td>49</td><td>48</td><td></td><td></td><td></td><td></td> </tr> <tr> <td colspan="4">73</td> <td></td><td>31</td><td>30</td><td>29</td><td>28</td> </tr> <tr> <td colspan="4"></td> <td>16</td><td>15</td><td>14</td><td>13</td><td>12</td> </tr> </table>	72		70							52	51		49	48					73					31	30	29	28					16	15	14	13	12	
	72		70																																									
52	51		49	48																																								
73					31	30	29	28																																				
				16	15	14	13	12																																				
C	AVAILABLE	NOT APPLICABLE	34566-8413	0	A	BLACK	<table border="1"> <tr> <td>72</td><td></td><td>70</td><td></td><td></td><td></td><td></td><td></td><td></td> </tr> <tr> <td>52</td><td>51</td><td></td><td>49</td><td>48</td><td></td><td></td><td></td><td></td> </tr> <tr> <td colspan="4">73</td> <td></td><td>31</td><td>30</td><td>29</td><td>28</td> </tr> <tr> <td colspan="4"></td> <td>16</td><td>15</td><td>14</td><td></td><td>12</td> </tr> </table>	72		70							52	51		49	48					73					31	30	29	28					16	15	14		12	
	72		70																																									
52	51		49	48																																								
73					31	30	29	28																																				
				16	15	14		12																																				
B	AVAILABLE	NOT APPLICABLE	34566-8423	0	C	BLUE	<table border="1"> <tr> <td></td><td></td><td></td><td>69</td><td></td><td>67</td><td></td><td></td><td>64</td> </tr> <tr> <td>52</td><td>51</td><td>50</td><td>49</td><td>48</td><td></td><td></td><td>46</td><td>45</td><td>44</td> </tr> <tr> <td colspan="4">73</td> <td></td><td></td><td></td><td></td><td>28</td> </tr> <tr> <td colspan="4"></td> <td>16</td><td>15</td><td>14</td><td>13</td><td>12</td> </tr> </table>				69		67			64	52	51	50	49	48			46	45	44	73								28					16	15	14	13	12
				69		67			64																																			
52	51	50	49	48			46	45	44																																			
73								28																																				
				16	15	14	13	12																																				
A	AVAILABLE	NOT APPLICABLE	34566-8433	0	H	ST GRY	<table border="1"> <tr> <td></td><td>79</td><td>78</td><td>77</td><td>76</td><td>75</td><td>74</td><td>73</td><td></td> </tr> <tr> <td></td><td></td><td></td><td></td><td></td><td></td><td></td><td></td><td></td> </tr> <tr> <td>20</td><td></td><td></td><td></td><td></td><td></td><td></td><td></td><td></td> </tr> </table>		79	78	77	76	75	74	73											20																		
		79	78	77	76	75	74	73																																				
20																																												

E	AVAILABLE	NOT APPLICABLE	34566-8493	0	B	ST.GRAY	<table border="1"> <tr> <td>52</td><td></td><td></td><td></td><td>48</td><td>47</td><td>46</td><td></td><td>44</td><td>43</td> </tr> <tr> <td colspan="4">73</td> <td></td><td></td><td>30</td><td></td><td></td><td></td> </tr> <tr> <td></td><td></td><td></td><td></td> <td>16</td><td>15</td><td>14</td><td></td><td></td><td></td> </tr> </table>	52				48	47	46		44	43	73						30								16	15	14														
	52				48	47	46		44	43																																						
73						30																																										
				16	15	14																																										
AVAILABLE	NOT APPLICABLE	34566-8513	9	A	BLACK	<table border="1"> <tr> <td>72</td><td>71</td><td>70</td><td>69</td><td>68</td><td></td><td>66</td><td>65</td><td>64</td><td>63</td> </tr> <tr> <td>52</td><td>51</td><td>50</td><td>49</td><td>48</td><td></td><td>46</td><td>45</td><td>44</td><td>43</td> </tr> <tr> <td colspan="4">73</td> <td>32</td><td>31</td><td>30</td><td>29</td><td>28</td><td></td> </tr> <tr> <td></td><td></td><td></td><td></td> <td></td><td>15</td><td>14</td><td>13</td><td>12</td><td></td> </tr> </table>	72	71	70	69	68		66	65	64	63	52	51	50	49	48		46	45	44	43	73				32	31	30	29	28							15	14	13	12			
72	71	70	69	68		66	65	64	63																																							
52	51	50	49	48		46	45	44	43																																							
73				32	31	30	29	28																																								
					15	14	13	12																																								
D	AVAILABLE	NOT APPLICABLE	34566-8523	9	B	ST.GRAY	<table border="1"> <tr> <td>72</td><td></td><td>70</td><td></td><td>68</td><td></td><td></td><td></td><td></td><td>62</td> </tr> <tr> <td>52</td><td></td><td></td><td></td><td>48</td><td>47</td><td>46</td><td></td><td></td><td>43</td> </tr> <tr> <td colspan="4">73</td> <td></td><td></td><td>30</td><td></td><td></td><td></td> </tr> <tr> <td></td><td></td><td></td><td></td> <td>16</td><td>15</td><td>14</td><td></td><td></td><td></td> </tr> </table>	72		70		68					62	52				48	47	46			43	73						30								16	15	14				
	72		70		68					62																																						
52				48	47	46			43																																							
73						30																																										
				16	15	14																																										
AVAILABLE	NOT APPLICABLE	34566-8533	9	C	BLUE	<table border="1"> <tr> <td></td><td></td><td>70</td><td></td><td></td><td>67</td><td>66</td><td>65</td><td>64</td><td></td> </tr> <tr> <td>52</td><td>51</td><td>50</td><td>49</td><td>48</td><td>47</td><td></td><td>45</td><td>44</td><td></td> </tr> <tr> <td colspan="4">73</td> <td>32</td><td></td><td></td><td></td><td>28</td><td>27</td> </tr> <tr> <td></td><td></td><td></td><td></td> <td>16</td><td>15</td><td>14</td><td>13</td><td>12</td><td>11</td> </tr> </table>			70			67	66	65	64		52	51	50	49	48	47		45	44		73				32				28	27					16	15	14	13	12	11		
		70			67	66	65	64																																								
52	51	50	49	48	47		45	44																																								
73				32				28	27																																							
				16	15	14	13	12	11																																							
C	AVAILABLE	NOT APPLICABLE	34566-8543	9	C	BLUE	<table border="1"> <tr> <td></td><td>71</td><td></td><td>69</td><td></td><td>67</td><td>66</td><td>65</td><td>64</td><td></td> </tr> <tr> <td>52</td><td>51</td><td>50</td><td>49</td><td>48</td><td>47</td><td>46</td><td>45</td><td>44</td><td></td> </tr> <tr> <td colspan="4">73</td> <td>32</td><td></td><td></td><td></td><td>28</td><td>27</td> </tr> <tr> <td></td><td></td><td></td><td></td> <td>16</td><td>15</td><td>14</td><td>13</td><td>12</td><td>11</td> </tr> </table>		71		69		67	66	65	64		52	51	50	49	48	47	46	45	44		73				32				28	27					16	15	14	13	12	11	
		71		69		67	66	65	64																																							
52	51	50	49	48	47	46	45	44																																								
73				32				28	27																																							
				16	15	14	13	12	11																																							
AVAILABLE	NOT APPLICABLE	34566-8543	9	C	BLUE	<table border="1"> <tr> <td></td><td>71</td><td></td><td>69</td><td></td><td>67</td><td>66</td><td>65</td><td>64</td><td></td> </tr> <tr> <td>52</td><td>51</td><td>50</td><td>49</td><td>48</td><td>47</td><td>46</td><td>45</td><td>44</td><td></td> </tr> <tr> <td colspan="4">73</td> <td>32</td><td></td><td></td><td></td><td>28</td><td>27</td> </tr> <tr> <td></td><td></td><td></td><td></td> <td>16</td><td>15</td><td>14</td><td>13</td><td>12</td><td>11</td> </tr> </table>		71		69		67	66	65	64		52	51	50	49	48	47	46	45	44		73				32				28	27					16	15	14	13	12	11		
	71		69		67	66	65	64																																								
52	51	50	49	48	47	46	45	44																																								
73				32				28	27																																							
				16	15	14	13	12	11																																							
B	G50	AVAILABLE	NOT APPLICABLE	34566-8543	9	C	BLUE	<table border="1"> <tr> <td></td><td>71</td><td></td><td>69</td><td></td><td>67</td><td>66</td><td>65</td><td>64</td><td></td> </tr> <tr> <td>52</td><td>51</td><td>50</td><td>49</td><td>48</td><td>47</td><td>46</td><td>45</td><td>44</td><td></td> </tr> <tr> <td colspan="4">73</td> <td>32</td><td></td><td></td><td></td><td>28</td><td>27</td> </tr> <tr> <td></td><td></td><td></td><td></td> <td>16</td><td>15</td><td>14</td><td>13</td><td>12</td><td>11</td> </tr> </table>		71		69		67	66	65	64		52	51	50	49	48	47	46	45	44		73				32				28	27					16	15	14	13	12	11
			71		69		67	66	65	64																																						
52	51	50	49	48	47	46	45	44																																								
73				32				28	27																																							
				16	15	14	13	12	11																																							
AVAILABLE	NOT APPLICABLE	34566-8543	9	C	BLUE	<table border="1"> <tr> <td></td><td>71</td><td></td><td>69</td><td></td><td>67</td><td>66</td><td>65</td><td>64</td><td></td> </tr> <tr> <td>52</td><td>51</td><td>50</td><td>49</td><td>48</td><td>47</td><td>46</td><td>45</td><td>44</td><td></td> </tr> <tr> <td colspan="4">73</td> <td>32</td><td></td><td></td><td></td><td>28</td><td>27</td> </tr> <tr> <td></td><td></td><td></td><td></td> <td>16</td><td>15</td><td>14</td><td>13</td><td>12</td><td>11</td> </tr> </table>		71		69		67	66	65	64		52	51	50	49	48	47	46	45	44		73				32				28	27					16	15	14	13	12	11		
	71		69		67	66	65	64																																								
52	51	50	49	48	47	46	45	44																																								
73				32				28	27																																							
				16	15	14	13	12	11																																							
A	AVAILABLE	NOT APPLICABLE	34566-8543	9	C	BLUE	<table border="1"> <tr> <td></td><td>71</td><td></td><td>69</td><td></td><td>67</td><td>66</td><td>65</td><td>64</td><td></td> </tr> <tr> <td>52</td><td>51</td><td>50</td><td>49</td><td>48</td><td>47</td><td>46</td><td>45</td><td>44</td><td></td> </tr> <tr> <td colspan="4">73</td> <td>32</td><td></td><td></td><td></td><td>28</td><td>27</td> </tr> <tr> <td></td><td></td><td></td><td></td> <td>16</td><td>15</td><td>14</td><td>13</td><td>12</td><td>11</td> </tr> </table>		71		69		67	66	65	64		52	51	50	49	48	47	46	45	44		73				32				28	27					16	15	14	13	12	11	
		71		69		67	66	65	64																																							
52	51	50	49	48	47	46	45	44																																								
73				32				28	27																																							
				16	15	14	13	12	11																																							
AVAILABLE	NOT APPLICABLE	34566-8543	9	C	BLUE	<table border="1"> <tr> <td></td><td>71</td><td></td><td>69</td><td></td><td>67</td><td>66</td><td>65</td><td>64</td><td></td> </tr> <tr> <td>52</td><td>51</td><td>50</td><td>49</td><td>48</td><td>47</td><td>46</td><td>45</td><td>44</td><td></td> </tr> <tr> <td colspan="4">73</td> <td>32</td><td></td><td></td><td></td><td>28</td><td>27</td> </tr> <tr> <td></td><td></td><td></td><td></td> <td>16</td><td>15</td><td>14</td><td>13</td><td>12</td><td>11</td> </tr> </table>		71		69		67	66	65	64		52	51	50	49	48	47	46	45	44		73				32				28	27					16	15	14	13	12	11		
	71		69		67	66	65	64																																								
52	51	50	49	48	47	46	45	44																																								
73				32				28	27																																							
				16	15	14	13	12	11																																							

RELEASE STATUS P1 RELEASE DATE 08.08.2017 01:37:07



E	SALEABLE	NOT APPLICABLE	34822-0223	0	A	BLACK	04	03	02	01	00	39	38	37	24
							65					31	28		8
D															
C															
B															
A															

RELEASE STATUS	P1	RELEASE DATE	08.08.2017	01:37:07
----------------	----	--------------	------------	----------

FORMAT: master-b-prod  
 REVISION: G  
 DATE: 2017/02/06

## X-ON Electronics

Largest Supplier of Electrical and Electronic Components

*Click to view similar products for [Automotive Connectors](#) category:*

*Click to view products by [Molex](#) manufacturer:*

Other Similar products are found below :

[003-018-000](#) [60403001](#) [60993906-B](#) [M902-2131](#) [M902-2161](#) [72.330.1035.1](#) [73.353.4028.0](#) [F119300-B](#) [F166900](#) [F258300-B](#) [F358300-B](#)  
[F407400](#) [F444110](#) [F487000](#) [F509500B-B](#) [827153-1](#) [8N1515-32-24P](#) [9-1326729-8](#) [925474-1](#) [928905-1](#) [964562-4](#) [968782-1](#) [GT17SA-8DS-](#)  
[HU](#) [98891-1012](#) [98947-1016](#) [12004147](#) [12004475-L](#) [12010290](#) [12010309-B](#) [12015454](#) [12020219-B](#) [12020308](#) [12041318-B](#) [12052466](#)  
[12059125](#) [12064869](#) [12004327-B](#) [12010503-B](#) [12015308](#) [12015384](#) [12015909](#) [1-21030-1](#) [12041254](#) [12041318](#) [12047946-B](#) [12047957](#)  
[12047957-L](#) [12059473](#) [12066261](#) [12110546](#)