

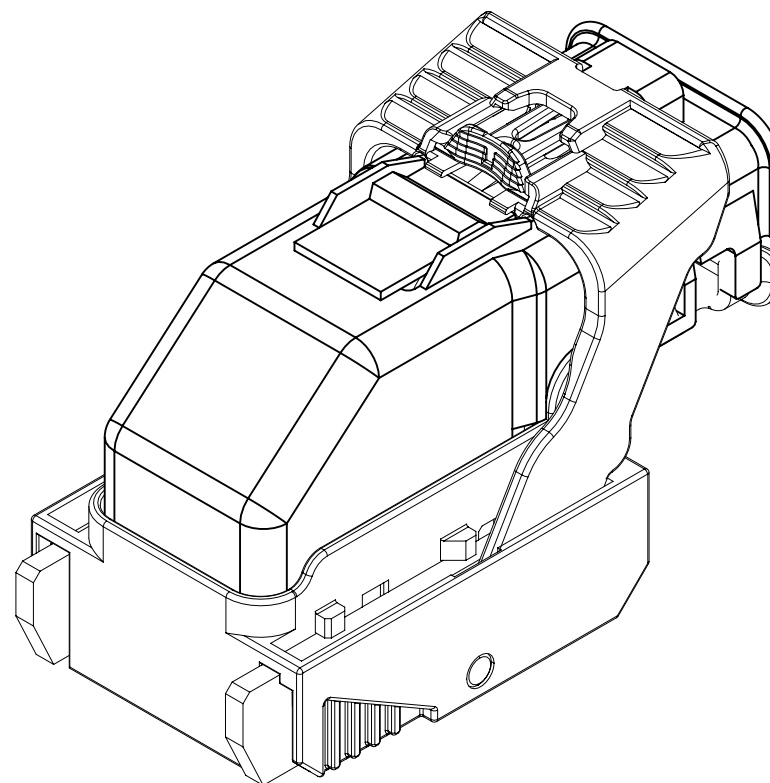

INDEX	
PAGE TITLE	PAGE
TITLE BLOCK	1
REVISION BLOCK	2
PART BLOCK	3
KPC BLOCK	4
COMPONENT TABLE	5
NOTES	6
NOTES	7
WIRE DRESS PACKAGING DIMENSIONS	8
LOCATION AND PACKAGING DIMENSIONS REFERENCING INTERFACE DATUMS B & C	9
LOCATION AND PACKAGING DIMENSIONS REFERENCING INTERFACE DATUM A	10
KEY ID REF - WIRE DRESS OPTION 0	11
KEY ID REF - WIRE DRESS OPTION 9	12
CIRCUIT CONFIGURATIONS	13
CIRCUIT CONFIGURATIONS	14
COMPONENT CONNECTOR INTERFACE	15
COMPONENT CONNECTOR INTERFACE	16
COMPONENT CONNECTOR INTERFACE	17
COMPONENT CONNECTOR INTERFACE	18
COMPONENT CONNECTOR INTERFACE	19
COMPONENT CONNECTOR INTERFACE	20
COMPONENT CONNECTOR INTERFACE	21
COMPONENT CONNECTOR INTERFACE	22



ISO VIEW

	THIS DOCUMENT IS IN ACCORDANCE WITH ASME Y14.5M-1994 AS AMENDED BY THE GM GLOBAL DIMENSIONING AND TOLERANCING ADDENDUM - 2004.			DATE
	 CHANGE RESTRICTED NO MANUAL CHANGES	REFERENCE 12H (MOLEX AUTOMOTIVE)	DRAFTER	D. KOEHLER
DO NOT SCALE	APVD1		M.R. OOSTERINK	29AP15
	APVD2	J. SWARTZ	29AP15	
	APVD3	G. FLECK	08MY15	
	APVD4			
	APVD5			
METRIC DIMENSIONS SHOWN IN MILLIMETERS UNLESS OTHERWISE SPECIFIED	DRAWING NAME HARNESS CONN ASM-SEALED 18/49/56 CKTS, MX123			
DRAWING NUMBER		DWG STATUS		PAGE NUMBER
12642694		ST	REV	PDI
		R	001	
				1 of 22

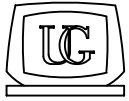
PAGE	DWG STATUS					REVISION HISTORY	AUTH	DR	CK	ENG
	DATE	ST	REV	CHG	PDI					

PAGE	DWG STATUS					REVISION HISTORY	AUTH	DR	CK	ENG
	DATE	ST	REV	CHG	PDI					
	08MY15	R	001			RELEASED TO PRODUCTION AT DLS A	CRMRJD	DFK	MRO	GF

KEY PRODUCT CHARACTERISTICS
(IN ACCORDANCE WITH QN 1805 OR ON 1050)



SAFETY/COMPLIANCE

TOTAL ON
DRAWING

5



FIT/FUNCTION

LAST NO.
USED

5

NO	TYPE	DESCRIPTION	RATIONALE	PAGE/ZONE
1	F/F	32.68	IMPROVE CONNECTOR SYSTEM MATING	16
2	F/F	29.00	INSURE PROPER RELEASE OF LEVER	16
3	F/F	15.25	INSURE FINAL MATE POSITION	17
5	F/F	POSITIONAL TOLERANCE (2 PLACES)	INSURE CONNECTOR SYSTEM MATIBILITY	20



PAGE TITLE
KPC BLOCK

DRAWING NUMBER

12642694

DWG STATUS

ST	REV	PD1
----	-----	-----

R	001	
---	-----	--

PAGE NUMBER

4 OF 22

P. No	MFG.	MFG. P/N	GM P/N	Effective Date	APPLICABLE COMPONENTS	Key Option	Wire Dress Option	Key Config.	Color	Status
					DESCRIPTION					
1	Molex	34575-0003	12582679	02JN03	WIRE HARNESS COVER	N/A	NA	N/A	BLACK	AVAILABLE
2	Molex	34576-0103	12666118	31JL15	HARN CONN ASM 49 CKT	A	0	1458	BLACK	ACTIVE
3	Molex	34576-0203	12650786	T.B.D.	HARN CONN ASM 49 CKT	B	0	1468	ST GRAY	NOT ACTIVE
4	Molex	34576-0303	12666120	31JL15	HARN CONN ASM 49 CKT	C	0	2467	BLUE	ACTIVE
5	Molex	34576-0403	12615660	T.B.D.	HARN CONN ASM 49 CKT	D	0	2367	BROWN	NOT ACTIVE
6	Molex	34576-0503	12615661	T.B.D.	HARN CONN ASM 49 CKT	E	0	2468	GREEN	NOT ACTIVE
7	Molex	34576-0603	12615662	T.B.D.	HARN CONN ASM 49 CKT	F	0	1357	NATURAL	NOT ACTIVE
8	Molex	34576-0703	12582680	11JN04	HARN CONN ASM 56 CKT	G	0	1358	BLUE	AVAILABLE
9	Molex	34576-0803	12582681	11JN04	HARN CONN ASM 56 CKT	H	0	2458	ST GRAY	AVAILABLE
10	Molex	34576-0903	12615658	T.B.D.	HARN CONN ASM 56 CKT	J	0	2457	BLACK	NOT ACTIVE
11	Molex	34576-1003	AVA77166	T.B.D.	HARN CONN ASM 56 CKT	K	0	2357	BROWN	NOT ACTIVE
12	Molex	34576-1103	AVA77167	T.B.D.	HARN CONN ASM 56 CKT	L	0	2368	GREEN	NOT ACTIVE
13	Molex	34576-1203	AVA77168	T.B.D.	HARN CONN ASM 56 CKT	M	0	2358	NATURAL	NOT ACTIVE
14	Molex	34576-1303	12666119	31JL15	HARN CONN ASM 49 CKT	A	9	1458	BLACK	ACTIVE
15	Molex	34576-1403	12650787	T.B.D.	HARN CONN ASM 49 CKT	B	9	1468	ST GRAY	NOT ACTIVE
16	Molex	34576-1503	12666121	31JL15	HARN CONN ASM 49 CKT	C	9	2467	BLUE	ACTIVE
17	Molex	34576-1603	12615663	T.B.D.	HARN CONN ASM 49 CKT	D	9	2367	BROWN	NOT ACTIVE
18	Molex	34576-1703	12615664	T.B.D.	HARN CONN ASM 49 CKT	E	9	2468	GREEN	NOT ACTIVE
19	Molex	34576-1803	12615665	T.B.D.	HARN CONN ASM 49 CKT	F	9	1357	NATURAL	NOT ACTIVE
20	Molex	34576-1903	12603600	11JN04	HARN CONN ASM 56 CKT	G	9	1358	BLUE	AVAILABLE
21	Molex	34576-2003	12603601	T.B.D.	HARN CONN ASM 56 CKT	H	9	2458	ST GRAY	NOT ACTIVE
22	Molex	34576-2103	12615659	T.B.D.	HARN CONN ASM 56 CKT	J	9	2457	BLACK	NOT ACTIVE
23	Molex	34576-2203	AVA77192	T.B.D.	HARN CONN ASM 56 CKT	K	9	2357	BROWN	NOT ACTIVE
24	Molex	34576-2303	AVA77193	T.B.D.	HARN CONN ASM 56 CKT	L	9	2368	GREEN	NOT ACTIVE
25	Molex	34576-2403	AVA77143	T.B.D.	HARN CONN ASM 56 CKT	M	9	2358	NATURAL	NOT ACTIVE
26	Molex	34851-0007	12644156	31AU15	HARN CONN ASM 18 CKT	G	0	1358	BLUE	ACTIVE
27	Molex	34851-0008	12644158	31AU15	HARN CONN ASM 18 CKT	H	0	2458	ST GRAY	ACTIVE
28	Molex	34851-0019	12644157	31AU15	HARN CONN ASM 18 CKT	G	9	1358	BLUE	ACTIVE
29	Molex	34851-0020	12644159	31AU15	HARN CONN ASM 18 CKT	H	9	2458	ST GRAY	ACTIVE
30	Molex	34736-2002	12642697	01AU10	MX64 RCPT TERM Ag 18/20 GAGE B (RIGHT PAYOFF)	N/A	N/A	N/A	N/A	AVAILABLE
31	Molex	34736-2001	12642696	01AU10	MX64 RCPT TERM Ag 22 GAGE B (RIGHT PAYOFF)	N/A	N/A	N/A	N/A	AVAILABLE
32	Molex	34586-0001	T.B.D.	11JN04	MX123 0.64MM GROMMET PLUG	N/A	N/A	N/A	NATURAL	AVAILABLE
33	Yazaki	7116-4150-02	12588066	02JN03	2.8mm YESC SEALED FEMALE TERMINAL TIN 20/22 GAGE (CABLE RANGE 0.30mm-0.60mm)	N/A	N/A	N/A	N/A	NOT ACTIVE
34	Yazaki	7116-4151-02	12588067	02JN03	2.8mm YESC SEALED FEMALE TERMINAL TIN 16/18 GAGE (CABLE RANGE 0.75mm-1.40mm)	N/A	N/A	N/A	N/A	NOT ACTIVE
35	Yazaki	7116-4152-02	12582685	02JN03	2.8mm YESC SEALED FEMALE TERMINAL TIN 14 GAGE (CABLE RANGE 1.50mm-2.50mm)	N/A	N/A	N/A	N/A	AVAILABLE
36	Yazaki	7158-3111-60	12588068	02JN03	2.8mm CABLE SEAL (wire O.D. range 1.20mm-1.90mm)	N/A	N/A	N/A	GREEN	NOT ACTIVE
37	Yazaki	7158-3112-70	12588069	02JN03	2.8mm CABLE SEAL (wire O.D. range 1.80mm-2.30mm)	N/A	N/A	N/A	YELLOW	NOT ACTIVE
38	Yazaki	7158-3113-40	12582686	02JN03	2.8mm CABLE SEAL (wire O.D. range 2.18mm-3.00mm)	N/A	N/A	N/A	WHITE	AVAILABLE
39	Yazaki	7158-3114-90	T.B.D.	02JN03	2.8mm YESC CAVITY PLUG	N/A	N/A	N/A	BLUE	AVAILABLE
40	FCI	33140138	12646399	10JA14	6.35mm APEX RCPT TERM Sn/Ag GRIP CODE-10 (6mm2) - Greased	N/A	N/A	N/A	N/A	AVAILABLE
41	FCI	33140135	12654556	10JA14	6.35mm APEX RCPT TERM Sn/Ag GRIP CODE-TBD (1mm2) - Greased	N/A	N/A	N/A	N/A	AVAILABLE
42	QSR	A-0549C	12646688	01SE14	6.35mm CABLE SEAL (FOR 6.0mm2 WIRE SIZE - 3.6 TO 4.2mm INSULATION OD)	N/A	N/A	N/A	WHITE	AVAILABLE
43	QSR	A-0549B	12654557	01SE14	6.35mm CABLE SEAL (FOR 0.75-1.25mm2 WIRE SIZE - 1.8 TO 2.3mm INSULATION OD)	N/A	N/A	N/A	BLUE	AVAILABLE
44	Molex	63811-4200	XX019825	02JN03	MX64 TERM HAND CRIMP TOOL	N/A	N/A	N/A	N/A	AVAILABLE
45	Molex	63813-1400	XX019826	02JN03	MX64 TERM SERVICE TOOL	N/A	N/A	N/A	N/A	AVAILABLE
46	Molex	63865-8000	XX019827	02JN03	MX64 CRIMP APPLICATOR with TOOL KIT 18/20 GAGE PAYOFF DIRECTION D (left payoff) (contact Molex for payoff detail)	N/A	N/A	N/A	N/A	AVAILABLE
47	Molex	63865-8070	XX019828	02JN03	MX64 APPLICATOR TOOL KIT 18/20 GAGE	N/A	N/A	N/A	N/A	AVAILABLE
48	Molex	63865-8100	XX019829	02JN03	MX64 CRIMP APPLICATOR with TOOL KIT 22 GAGE PAYOFF DIRECTION D (left payoff) (contact Molex for payoff detail)	N/A	N/A	N/A	N/A	AVAILABLE
49	Molex	63865-8170	XX019830	02JN03	MX64 APPLICATOR TOOL KIT 22 GAGE	N/A	N/A	N/A	N/A	AVAILABLE
50	SPX	J35616-64	T.B.D.	02JN03	0.64mm PROBE TOOL (for rcpt)	N/A	N/A	N/A	N/A	AVAILABLE
51	SPX	J35616-64A	T.B.D.	02JN03	0.64mm PROBE TOOL WITH EXT (for rcpt)	N/A	N/A	N/A	N/A	AVAILABLE
52	SPX	J35616-65	T.B.D.	02JN03	0.64mm PROBE TOOL WITH EXT (for pin)	N/A	N/A	N/A	N/A	AVAILABLE
53	SPX	J35616-4A	T.B.D.	02JN03	2.8mm PROBE TOOL (for rcpt)	N/A	N/A	N/A	N/A	AVAILABLE
54	YAZAKI	X39899-J374	12094430	02JN03	2.8mm TERM SERVICE TOOL	N/A	N/A	N/A	N/A	AVAILABLE
55	TQ1	7000-1001	N/A	01FE15	18CKT PASS THROUGH ADAPTERS	N/A	N/A	N/A	BLACK	AVAILABLE
56	TQ1	7000-1004	N/A	01FE15	49CKT PASS THROUGH ADAPTERS	N/A	N/A	N/A	BLACK	AVAILABLE
57	TQ1	79917-0060	N/A	02JA08	56CKT PASS THROUGH ADAPTERS	N/A	N/A	N/A	BLACK	AVAILABLE
58	Molex	63813-1500	J-38125-217	01SE14	6.35mm APEX TERM SERVICE TOOL	N/A	N/A	N/A	N/A	AVAILABLE

* MX123 WIRE HARNESS COVER MATES TO ANY 18/49/56 CKT MX123 HARN CONN ASSY SHOWN ON THIS TABLE

	PAGE TITLE	DRAWING NUMBER	DWG STATUS			PAGE NUMBER
	COMPONENT TABLE	12642694	ST	REV	PDI	5 of 22
			R	001		

NOTES: UNLESS OTHERWISE SPECIFIED

1. MATERIAL FOR INTERFACE:

- A. RESIN:
 - 1. 30% G.F. PBT; 20% MAX. (BY WEIGHT) REGRIND.
 - 2. MATING CONNECTOR INTERFACE PART COLOR MUST BE SAME AS MATCHING KEYED HARNESS CONNECTOR ASSEMBLY.
 - 3. MUST BE VALIDATED FOR INDIVIDUAL DEVICE APPLICATION REQUIREMENTS.
- B. 0.64MM PINS:
 - 1. BASE MATERIAL: COPPER ALLOY; CONDUCTIVITY >= 28% IACS AT 20°C; TENSILE STRENGTH >= 635 N/mm²; SURFACE ROUGHNESS R_a 6 MAX.
 - 2. PLATING FINISH: SILVER (Ag). PLATING TO BE 1.9-3.3 μm ELECTRODEPOSITED SEMI-BRIGHT SILVER OVER 1.25-2.25 μm DUCTILE SULPHAMATE NICKEL PER NOTE 1(D).
 - 3. ANTI-TARNISH: SYNTHETIC HYDROCARBON CONTACT SURFACE FINISH OR EQUIVALENT APPLIED WITHOUT VOID TO CONTACT AREA (MIN 3.7mm FROM PIN TIP).
- C. 2.8MM BLADE:
 - 1. BASE MATERIAL: COPPER ALLOY; CONDUCTIVITY >= 28% IACS AT 20°C; TENSILE STRENGTH >= 350 N/mm²; SURFACE ROUGHNESS R_a 6 MAX.
 - 2. PLATING FINISH: TIN. PLATING TO BE 2.5-5.0 μm ELECTRODEPOSITED TIN, MATTE FINISH OVER 1.25-2.5μm DUCTILE SULPHAMATE NICKEL PER NOTE 1(D).
- D. 6.3MM BLADE:
 - 1. BASE MATERIAL: COPPER ALLOY; CONDUCTIVITY >= 50% IACS AT 20°C;
 - 2. PLATING FINISH: SILVER (Ag) PLATING TO BE 1.9-3.3 μm ELECTRODEPOSITED SEMI-BRIGHT SILVER, OVER 1.25-2.5μm DUCTILE SULPHAMATE NICKEL PER NOTE 1(D) WITH ENVIRONMENTAL BARRIER OR TIN/SILVER (ELECTRO-DEPOSITED), UNDERPLATE 0.5-2.0 μm NICKEL OR COPPER. TOP PLATING: 1.0-3.0 μm (SILVER RANGE 3.75-X.XX NO ANTI-TARNISH COATING REQUIRED).

E. PLATING REQUIREMENTS:

- 1. SILVER PLATING
 - a. 99.5% PURE SEMI-BRIGHT WITH NO ORGANIC BRIGHTNERS OR CHROMATES.
- 2. NICKEL PLATING
 - a. ELECTRODEPOSITED DUCTILE SULFAMATE NICKEL WITH A NON-BRIGHTENED FINISH. NO ORGANIC OR BRIGHTENING AGENTS SHALL BE ALLOWED.
 - b. SHALL ONLY BE USED AS AN UNDERLYING PLATING AND MAY NOT BE USED AS AN ELECTRICAL CONTACT SURFACE PLATING.
 - c. SHALL BE NODULE FREE WHEN VIEWED AT 10X MAGNIFICATION IN MEASURED IN CONTACT SURFACE AREA PLUS 0.5MM PERIMETER AROUND THE CONTACT SURFACE AREA.
 - d. ALL PLATINGS SHALL HAVE A 1.0% MAXIMUM BY WEIGHT IMPURITIES. IMPURITIES ARE DEFINED AS ALL ELEMENTS NOT THE PRIMARY PLATING OR HARDENING AGENT IF APPLICABLE, AS DETERMINED BY WET CHEMICAL ANALYSIS OR AUGER METHOD. NO SINGLE IMPURITY SHALL EXCEED 0.1% MAXIMUM BY WEIGHT.
- 3. TESTING
 - a. THICKNESS TO BE MEASURED IN CONTACT SURFACE AREA PLUS 0.5MM PERIMETER AROUND THE CONTACT SURFACE AREA AS DESIGNATED IN THE DRAWING. THICKNESS SHALL BE DETERMINED BY METHOD OF X-RAY (XRF).
 - b. PLATING ADHESION SHALL BE TESTED BY A BEND TEST FOR ALL METALS. THE TEST SAMPLE SHALL BE BENT 90 DEGREES TO DETERMINE DEPOSIT ADHESION. TESTING SHALL BE COMPLETED IN ACCORDANCE WITH ASTM SPEC B571.

2. DESIGN - GENERAL:

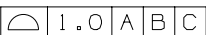
- A. THIS IS A 100% CAD GENERATED PART. THE CAD MATHEMATICAL DATA IS THE MASTER FOR THIS PART. WHERE DIMENSIONS ARE SPECIFIED ON THE DRAWING, THE DRAWING IS THE AUTHORITY FOR DIMENSIONAL VALUES. FOR DIMENSIONAL OR ANY INFORMATION NOT SHOWN ON THIS DRAWING, ANALYZE THE CAD MODEL.
- B. DIMENSIONS OBTAINED FROM THE DIGITAL MODEL ARE BASIC:
 - 1. FOR RELATIONSHIPS BETWEEN FEATURES WHEN ESTABLISHED BY GEOMETRIC TOLERANCES.
 - 2. FOR THE FORM OF A FEATURE WHEN CONTROLLED BY A PROFILE TOLERANCE.
 - 3. FOR THE SIZE, FORM AND/OR RELATIONSHIP BETWEEN FIXED DATUM TARGETS.
- C. DIMENSIONS OBTAINED FROM THE DIGITAL MODEL ARE ROUNDED TO TWO DECIMAL PLACES (PER IEEE/ASTM SI 10-2002)
- D. VIEWS AND SECTIONS ON THIS DRAWING ARE IN ACCORDANCE WITH GM DCS SECTION C3.
- E. THE DIGITAL MODEL MUST CORRESPOND TO THE RELEASE LEVEL SHOWN IN THE PART BLOCK ON THIS DOCUMENT.
- F. TOLERANCES:
 - 1. LINEAR
 - 0.X ± 0.30
 - 0.XX ± 0.10
 - 0.XXX ± 0.10
 - 2. ANGULAR X° ± 3°
 - 3.  1.0 A B C
- G. MINIMUM WALL THICKNESS REQUIRED: 1.3mm.
- H. CORNERS SHOWN AS SHARP TO BE R 0.2 MAX.
- J. LETTERING SHALL BE 0.15 MAX RAISED IN 0.20 MAX RECESS PAD. THIS INCLUDES MATERIAL CODE, RECYCLING CODE, CAVITY ID AND DATE CODE.
- K-1. PARTS MUST BE FREE OF DISCOLORATION, SALT RESIDUE AND OTHER IMPERFECTIONS THAT AFFECT FIT OR FUNCTION.
- K-2. SCRATCHES OR DENTS NOT TO EXCEED 0.013mm IN DEPTH.
- L. FOLLOWING PRODUCTION CODES TO BE PERMANENTLY MARKED & HUMAN READABLE TO A LETTER HEIGHT OF 1.5 ± 0.5MM X 0.3 MAX DEEP
 - 1. MATERIAL #: XXXXX-XXXX
 - 2. DATE CODE: JJYY (JULIAN DAY, LAST DIGIT OF YEAR)
 - 3. INSPECTION MACHINE CODE + SERIAL #: X_XXXXX

3. DESIGN - MANUFACTURING:

- A. DRAFT TO BE WITHIN TOLERANCE.
- B. ALLOWABLE FLASH MAX 0.2 HIGH X MAX 0.13 THICK.
- C. ALLOWABLE PARTING LINE MISMATCH 0.2 MAX.
- D. EJECTOR PINS MARK TO BE FLUSH TO 0.25 MAX DEPRESSED.
- E. ALLOWABLE GATE VESTIGE FLUSH TO 0.25 MAX PROTRUSION.
- F. NO EXTERNAL MOLD RELEASE AGENT ALLOWED DURING MANUFACTURING.
- G. STEEL THAT FORMS THE INDICATED SURFACE MUST BE POLISHED WITH A DIAMOND FINISH (SPI A-2) OVER THE FULL PERIPHERY OF THE TOOL. SURFACE MUST HAVE NO MISMATCH.
- H. ANY PROCESS LUBRICANT REMAINING ON THE TERMINAL MUST NOT VARNISH OR DEGRADE IT'S ELECTRICAL PERFORMANCE UP TO A MAXIMUM CLASS AMBIENT TEMPERATURE PER SAE USCAR-2 FOR 1008 HOURS. PROCESS LUBRICANTS SHOULD BE APPROVED BY THE RESPONSIBLE ENGINEER.
- J. OPTIONAL FEATURES PROVIDED FOR AUTOMATION.
- K. PART MUST BE FREE FROM BURRS AND SHARP EDGES, WHICH MIGHT BE DETRIMENTAL TO SATISFACTORY ASSEMBLY, SAFE HANDLING OR FUNCTION OF PART.
- L. PARTS AS DELIVERED TO ASSEMBLY SHALL BE CLEAN AND FREE OF DEBRIS, RESIDUAL ABRASIVE MATERIAL AND CORROSION PRODUCTS ADVERESLY AFFECTING FUNCTION OR APPEARANCE.
- M. RESTRICTED AND REPORTABLE SUBSTANCES FOR PARTS PER GMW3059.

	PAGE TITLE	DRAWING NUMBER	DWG STATUS			PAGE NUMBER	
	NOTES		12642694	ST	REV		PDI
	R			001			6 of 22

NOTES: UNLESS OTHERWISE SPECIFIED

4. SYSTEM REQUIREMENTS:

- A. HARNESS CONNECTOR IS COMPATIBLE WITH THE FOLLOWING WIRE SIZE NO'S:
 SAE 14AWG, MEETING SAE J1128
 SAE 18AWG, MEETING SAE J1128, MAX O.D. OF 2.06 MM
 SAE 20AWG, MEETING SAE J1128
 SAE 22AWG, MEETING SAE J1128, MIN O.D. OF 1.47 MM
 ISO 6mm², FLR2X-A/T-125 PER GM 15626 (FEB 2008)
- B. CABLE TIE SPECIFICATIONS:
 1. CABLE TIE:
 TENSILE RATING: 220N / (50lbs) MIN
 TIE LENGTH: 186mm MIN
 TIE WIDTH: 4.75mm MAX
 MATERIAL: NYLON
 2. INSTALLATION:
 CABLE TIE TENSION: 190N MIN
 3. DRESSED WIRE BUNDLE PACKAGING: SEE FIG. 1
- C. WHEN MATED WITH COMPONENT CONNECTOR INTERFACE AND/OR DRESS COVER, HARNESS CONNECTOR SYSTEM CONFORMS TO THE FOLLOWING:
 1. SAE/USCAR-2, REV: 3 APRIL, 2001; CLASS 3
 2. FIELD CORRELATED LIFE TEST, SAE/USCAR-20, NOV. 2001
 3. GMW #3191 AUGUST 22, 2000 (DRAFT); TEMPERATURE CLASS 3 (145°C), SEALING CLASS 1 (HIGH PRESSURE SPRAY), VIBRATION CLASS 2 (ON BODY)
 4. TPA USER FORCES (FULLY POPULATED WITH TERMINALS)
 a. REMOVAL FROM LOCK TO PRE-SET: <=120N
- D. WIRE SPECIFICATIONS:
 1. WIRE SURFACE MUST BE FREE OF SCRATCHES, GROOVES OR DENTS WHERE FUNCTIONAL

5. TERMINAL CURRENT RATINGS:

ALL TESTING DONE IN ACCORDANCE WITH USCAR-2 REV5 SECTION 5.3

- A. MX64 RCPT TERM
 1. MX64 RCPT TERM Ag 18/20 GAGE CRIMPED TO SAE WIRE SIZE NO.18 AND MATED TO MX123 0.64MM PIN: 11.3 AMPS
 2. MX64 RCPT TERM Ag 22 GAGE CRIMPED TO SAE WIRE SIZE NO.22 AND MATED TO MX123 0.64MM PIN:8.5 AMPS

WIRE	CURRENT RATING			
	23 deg.C	85 deg.C	105 deg.C	125 deg.C
18AWG	11.3A	11.3A	9.5A	6.6A
20AWG	10.0A	10.0A	8.3A	5.7A
22AWG	8.6A	8.6A	7.1A	5.0A

- B. 2.8MM RCPT TERM
 1. 2.8MM RCPT TERM TIN 14 GAGE CRIMPED TO SAE WIRE SIZE NO.14 AND MATED TO MX123 2.8MM BLADE: 25.6 AMPS
- C. 6.3MM RCPT TERM - FCI APEX
 1. 6.3MM RCPT TERM TIN/SILVER CRIMPED TO 6.0MM² WIRE AND MATED TO MOLEX 6.3MM² BLADE (Sn/Ag PLATED):36A AT 125°C
6. CONTACT MOLEX AUTOMOTIVE FOR AVAILABLE CUSTOM PATTERNS OF CAVITIES OPEN FOR CIRCUITS



PAGE TITLE
 NOTES

DRAWING NUMBER
 12642694

DWG STATUS		
ST	REV	PDI
R	001	

PAGE NUMBER
 7 of 22

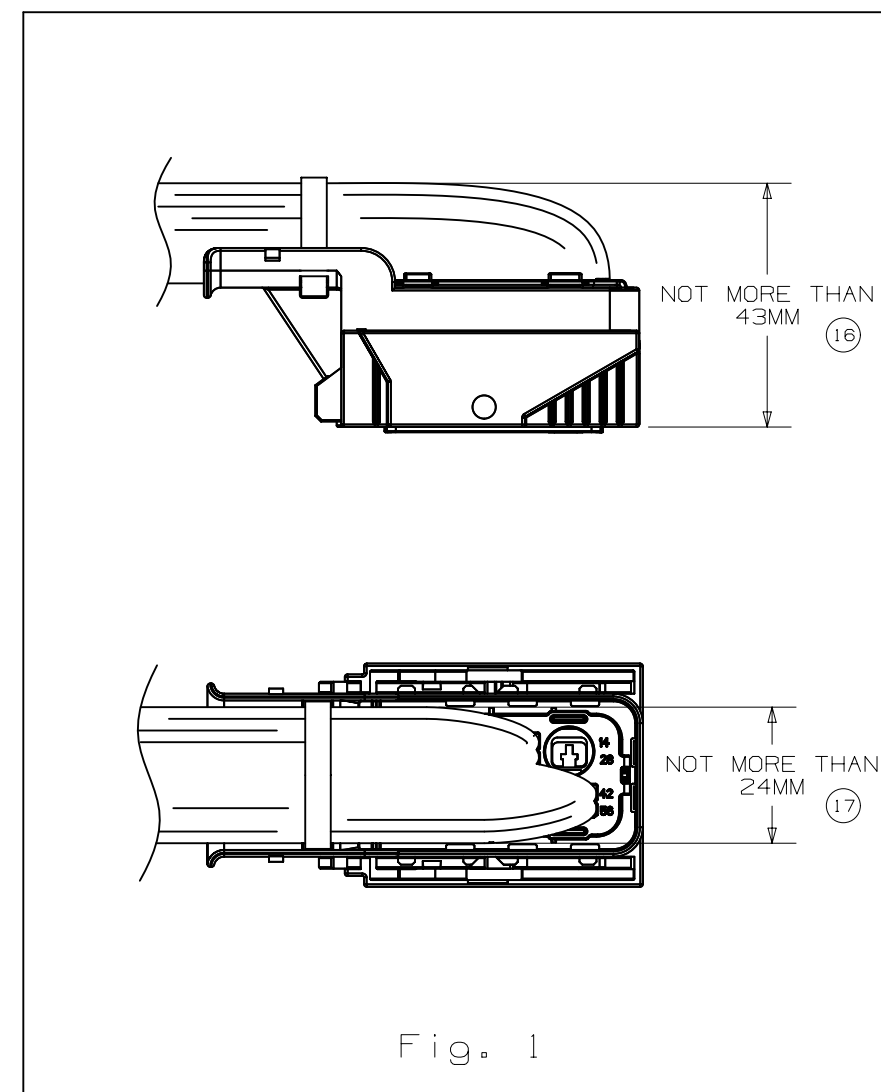
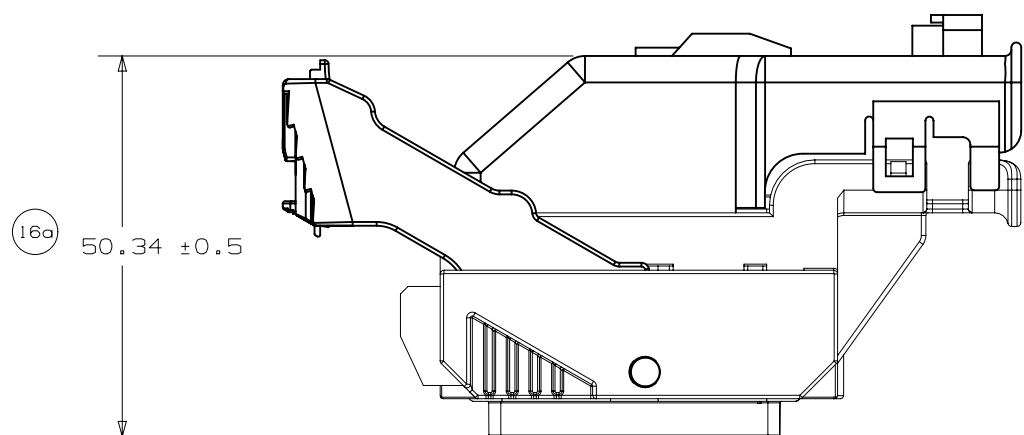

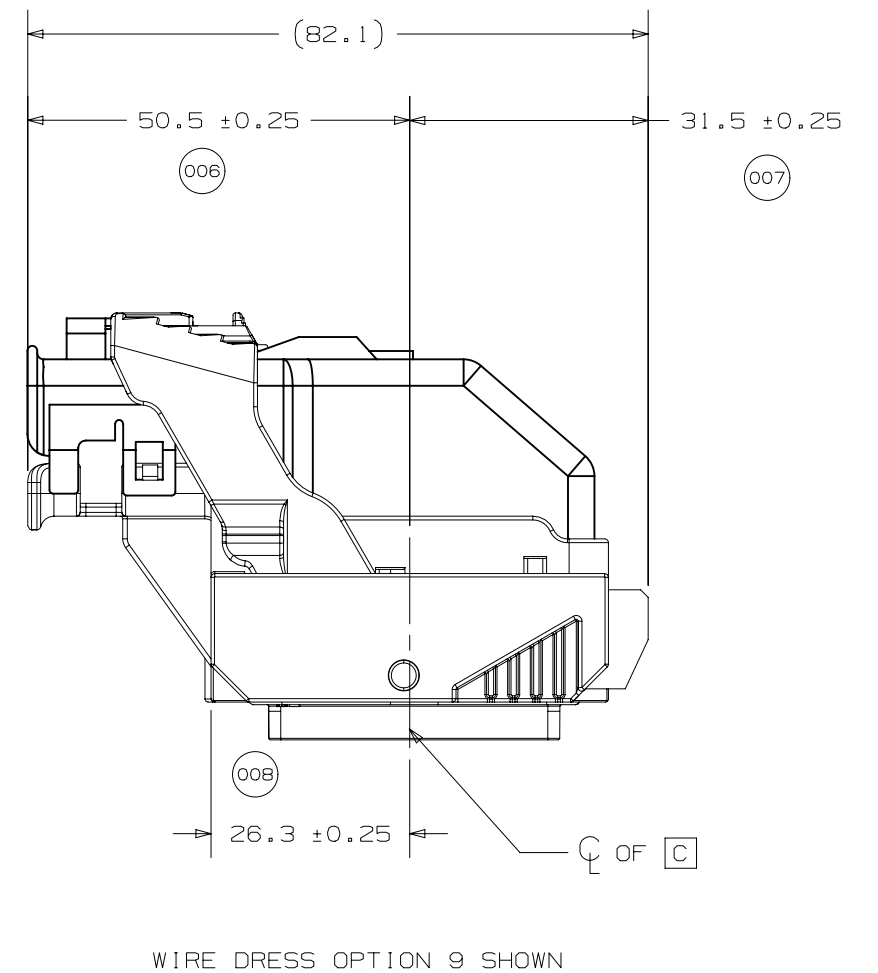
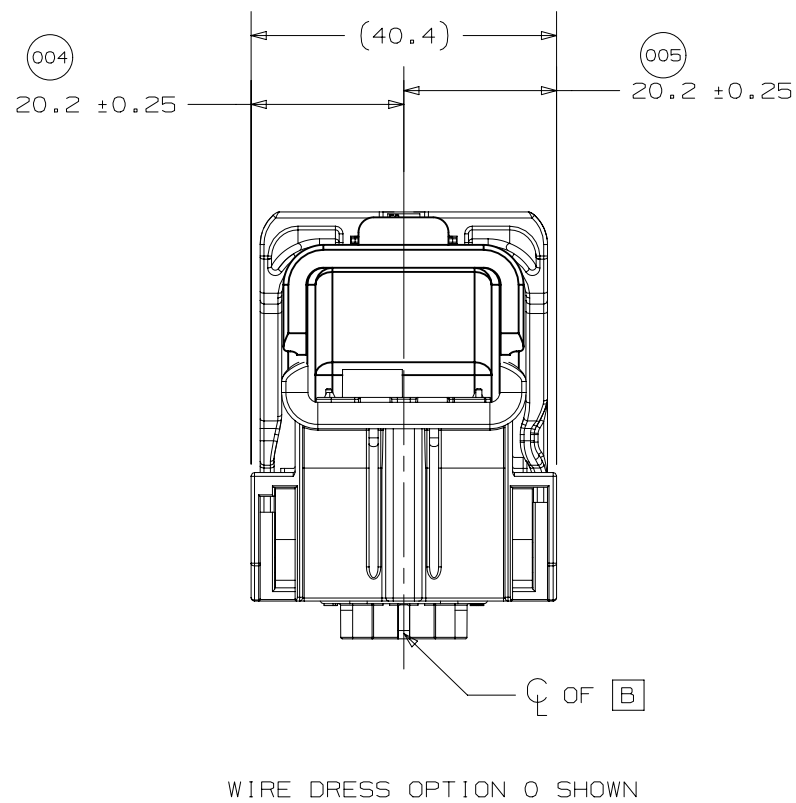
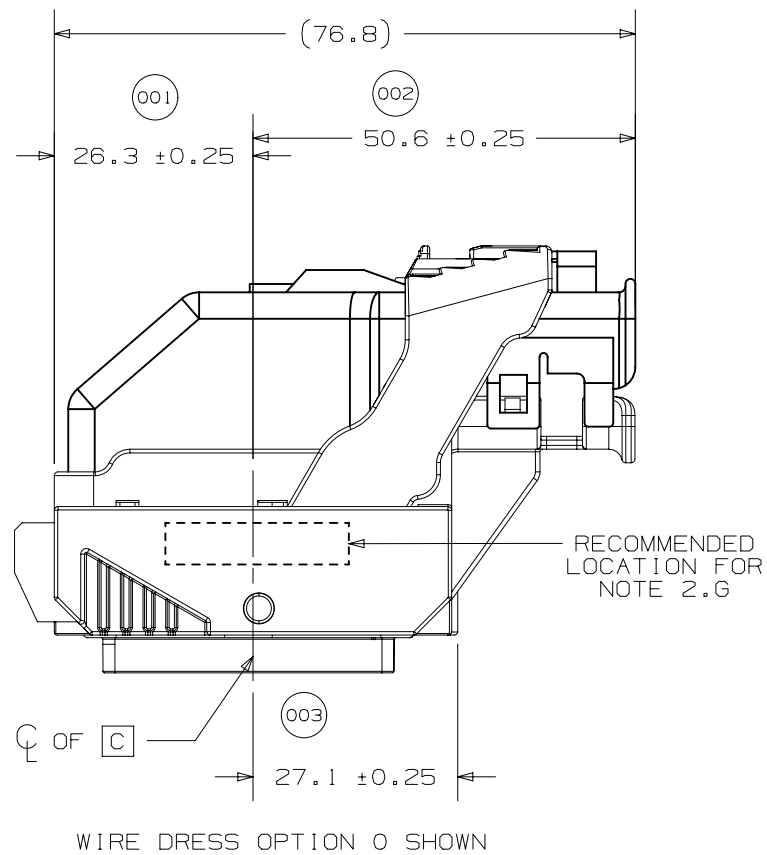

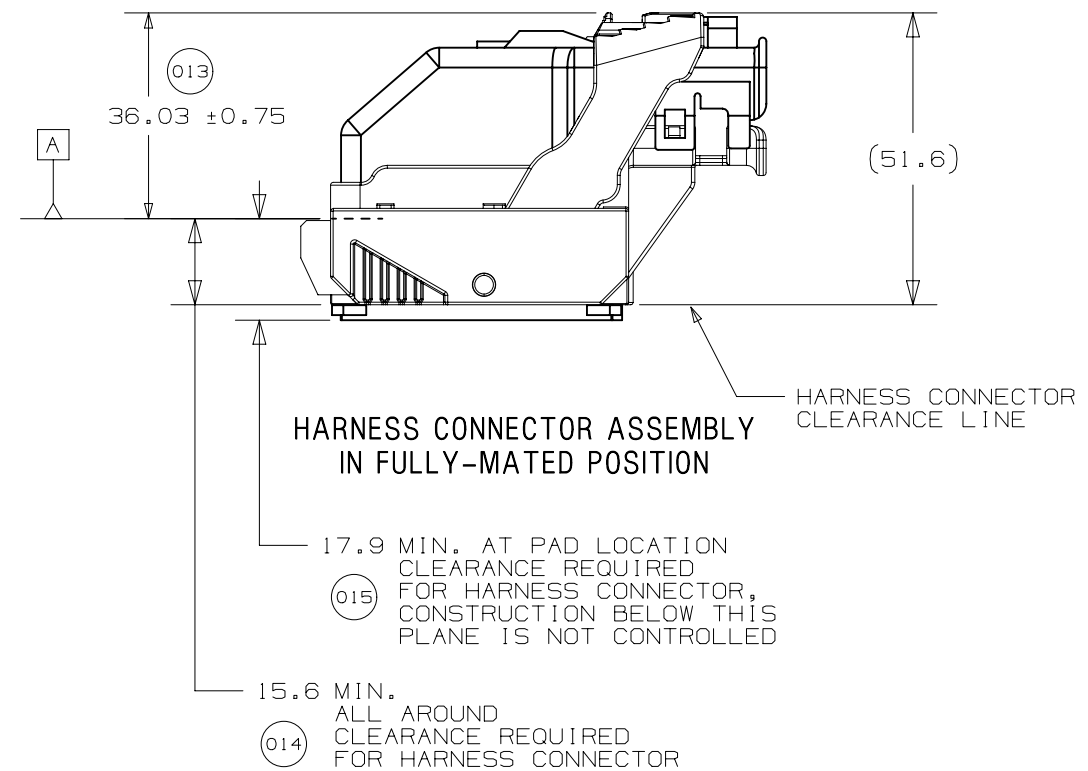
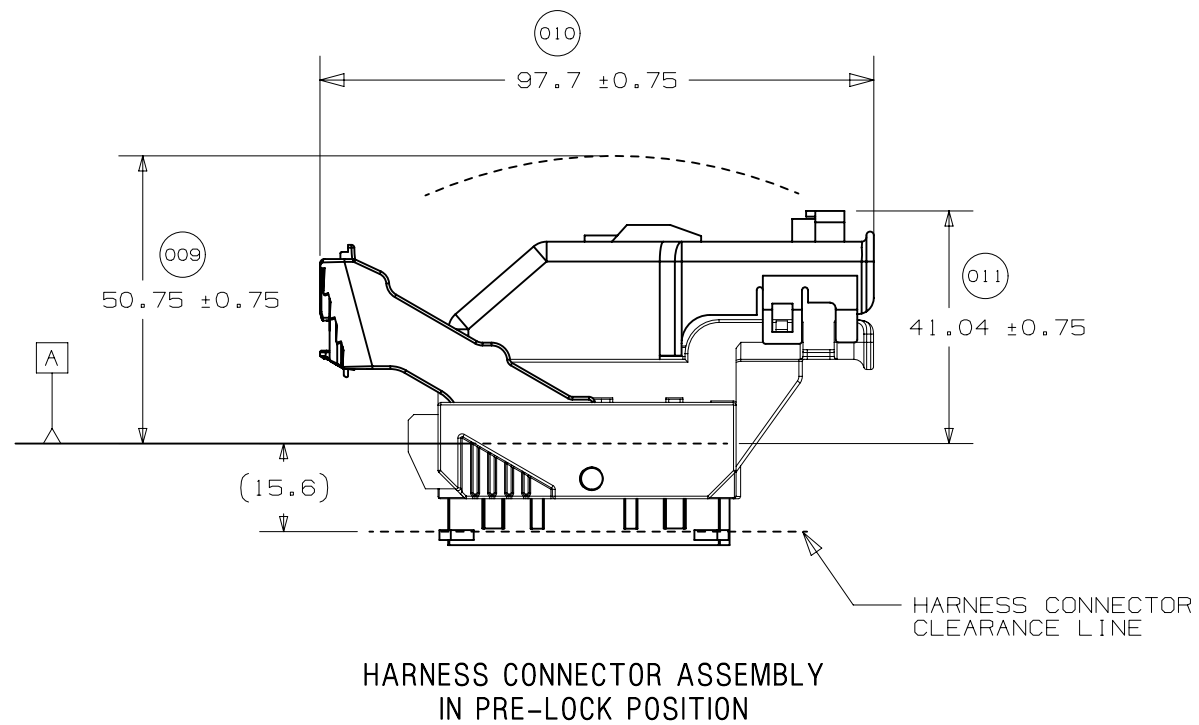
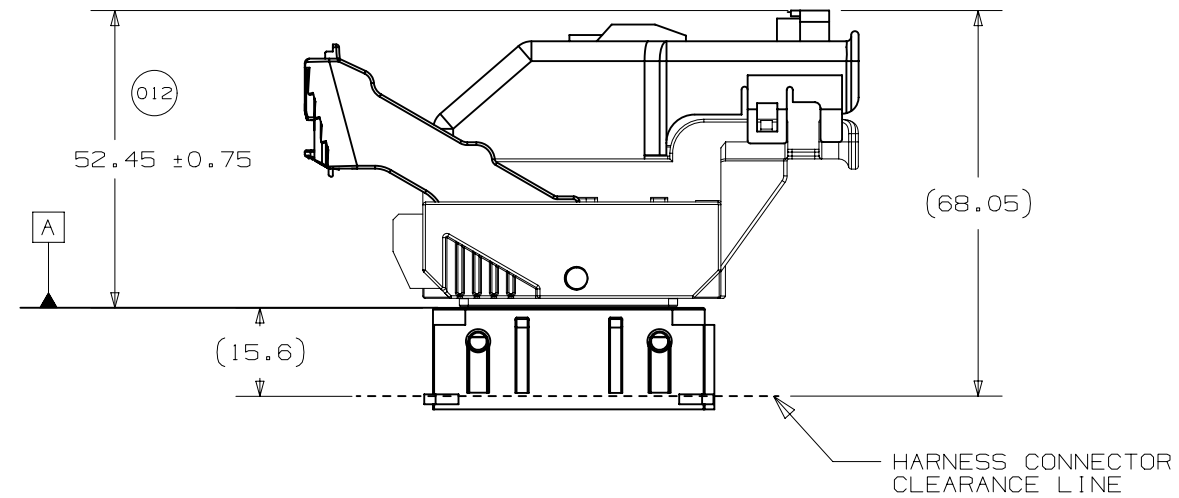

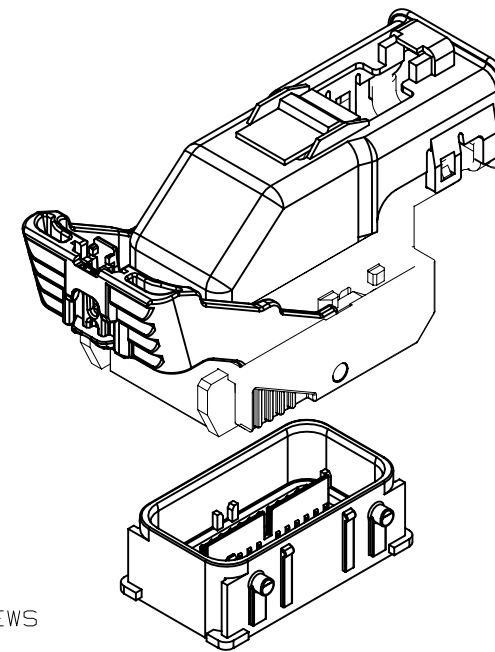
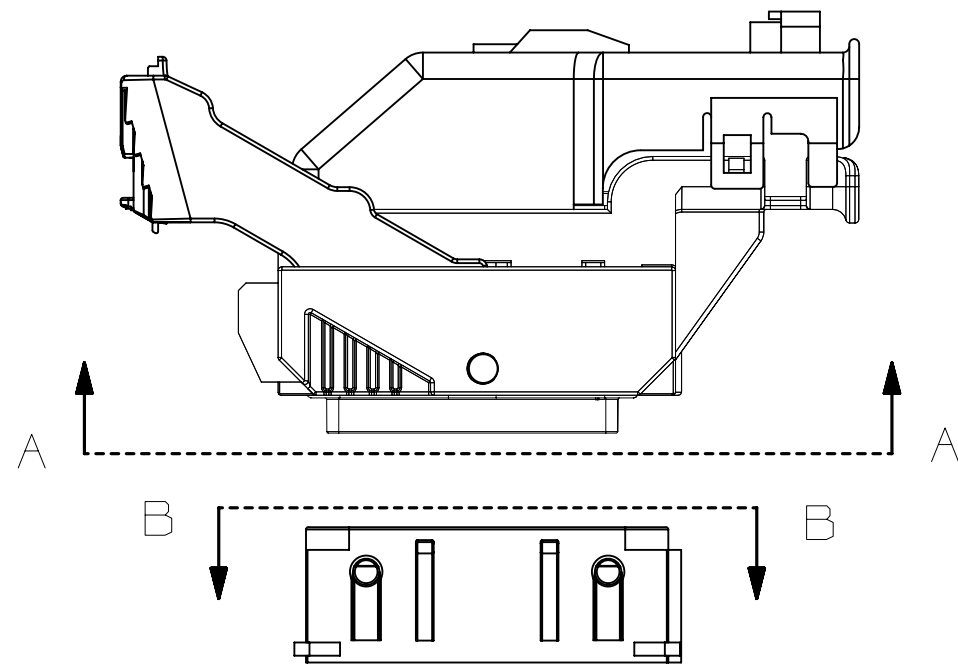

NOTE: REFERENCE THE COMPONENT TABLE FOR KEY OPTIONS AND CONFIGURATIONS

INTERFACE SIDE SHOWN IN ALL SECTION VIEWS

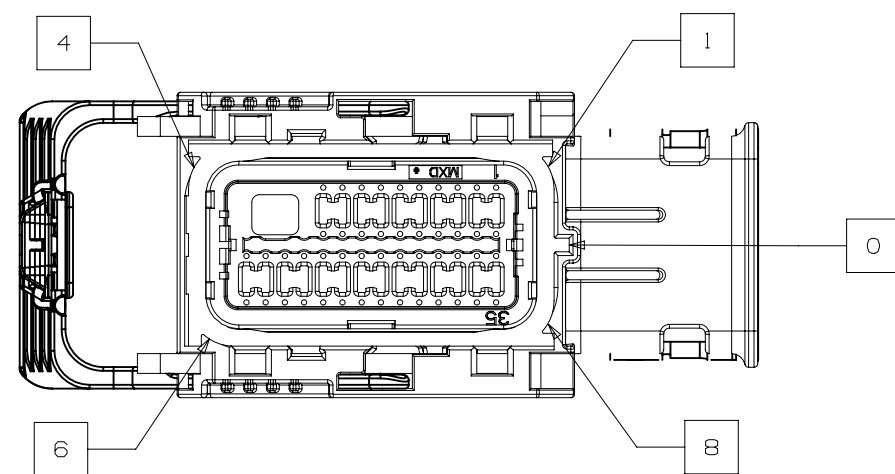

SECTION A-A
KEY OPTION B SHOWN

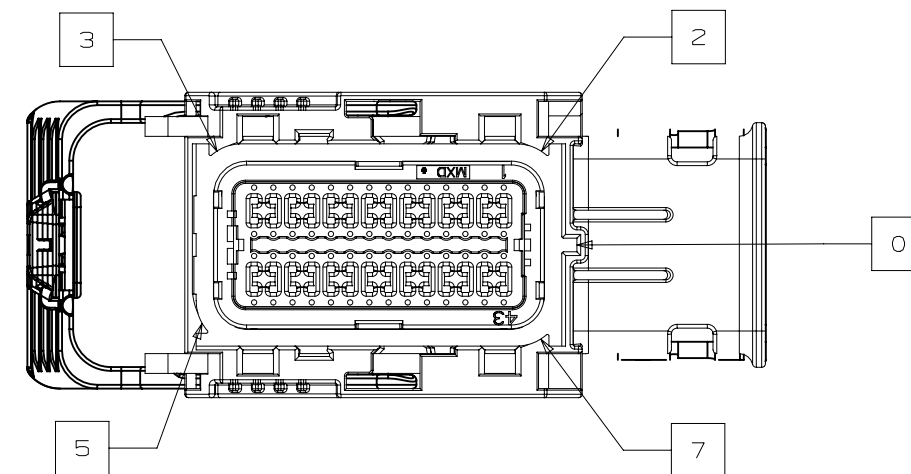

SECTION A-A
KEY OPTION K SHOWN

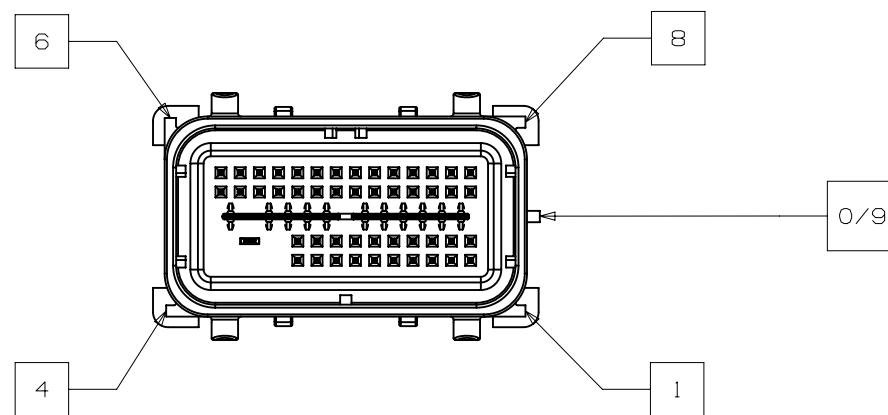

SECTION B-B
KEY OPTION B SHOWN

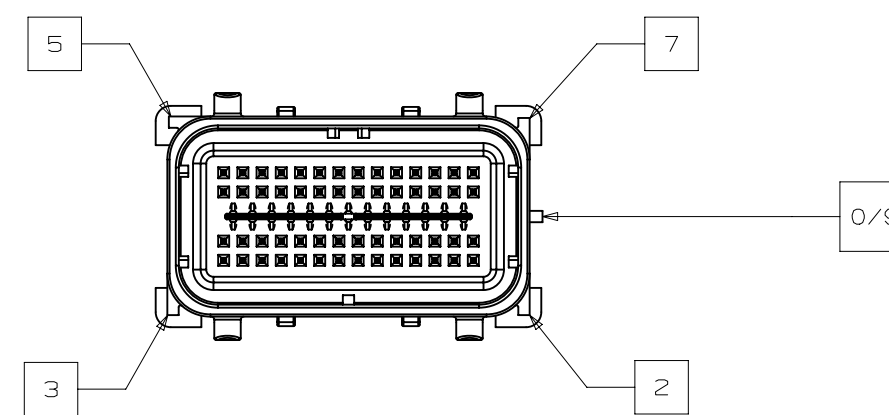

SECTION B-B
KEY OPTION K SHOWN



PAGE TITLE
KEY ID REF - WIRE DRESS OPTION 0

DRAWING NUMBER
12642694

DWG STATUS		
ST	REV	PD1
R	001	

PAGE NUMBER
11 OF 22

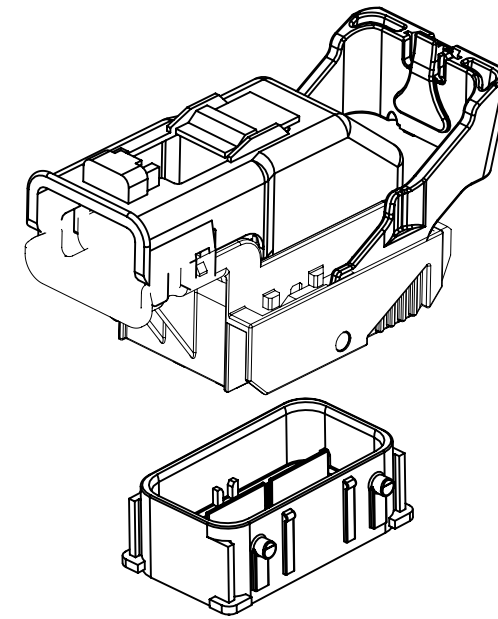
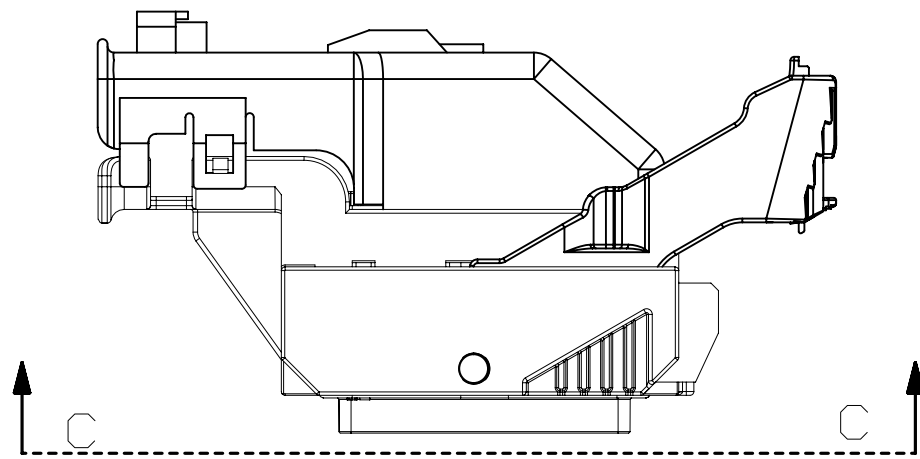

NOTE: REFERENCE THE COMPONENT TABLE FOR KEY OPTIONS AND CONFIGURATIONS

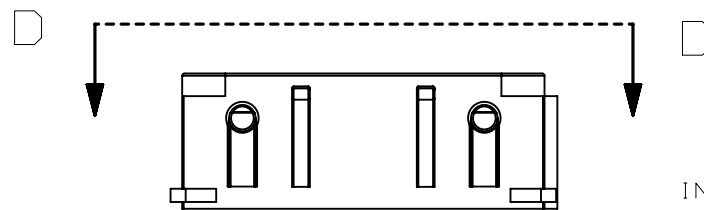

INTERFACE SIDE SHOWN ON ALL SECTION VIEWS

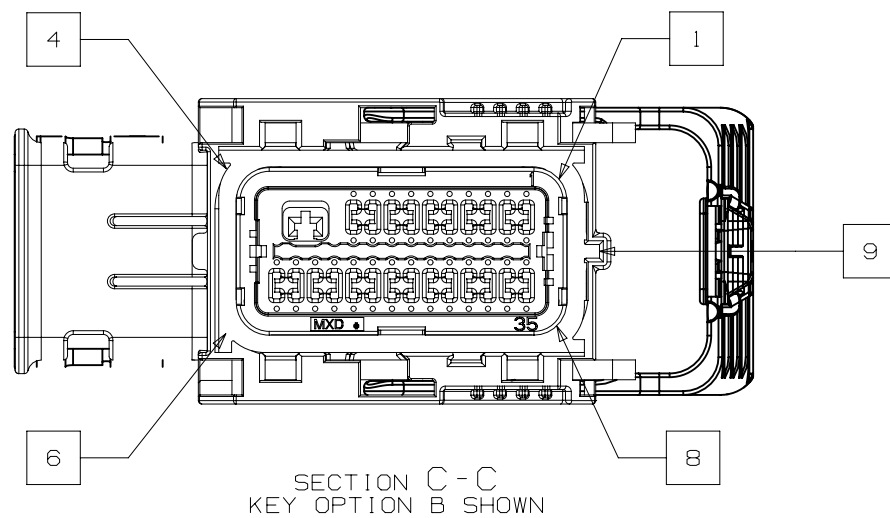

SECTION C-C
KEY OPTION B SHOWN

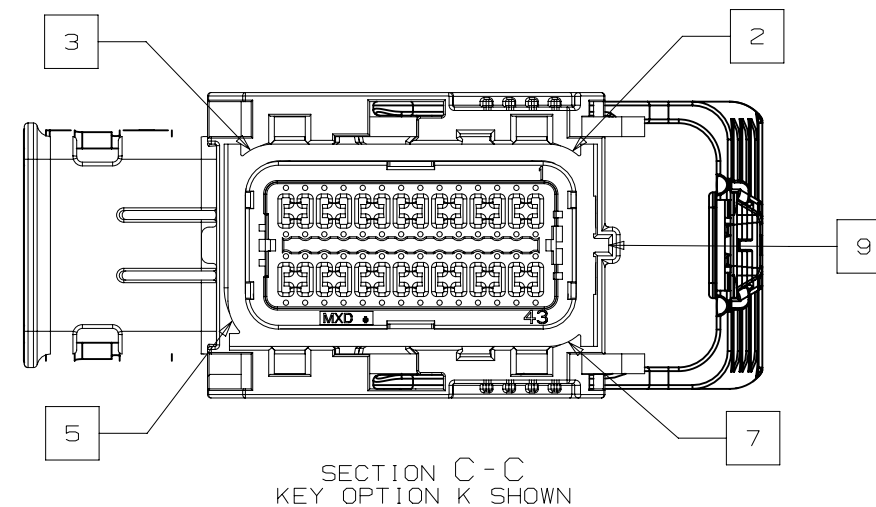

SECTION C-C
KEY OPTION K SHOWN

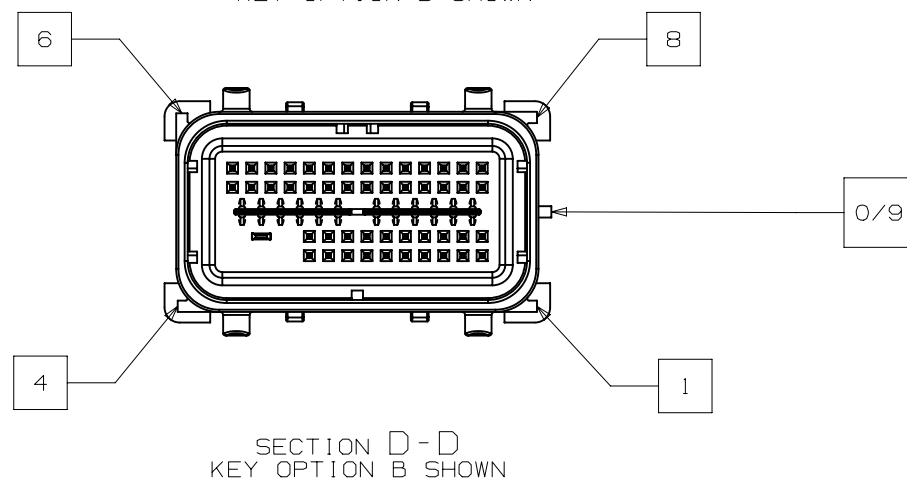

SECTION D-D
KEY OPTION B SHOWN

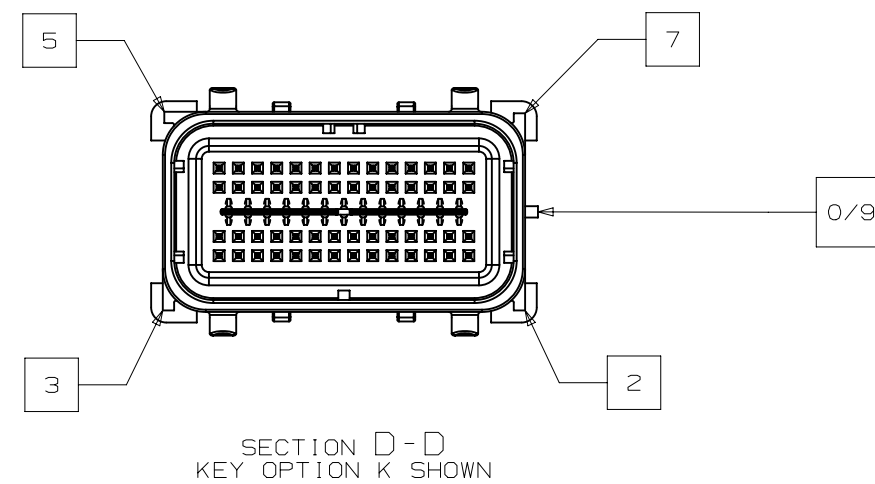

SECTION D-D
KEY OPTION K SHOWN



PAGE TITLE
KEY ID REF - WIRE DRESS OPTION 9

DRAWING NUMBER
12642694

DWG STATUS		
ST	REV	PD1
R	001	

PAGE NUMBER
12 OF 22

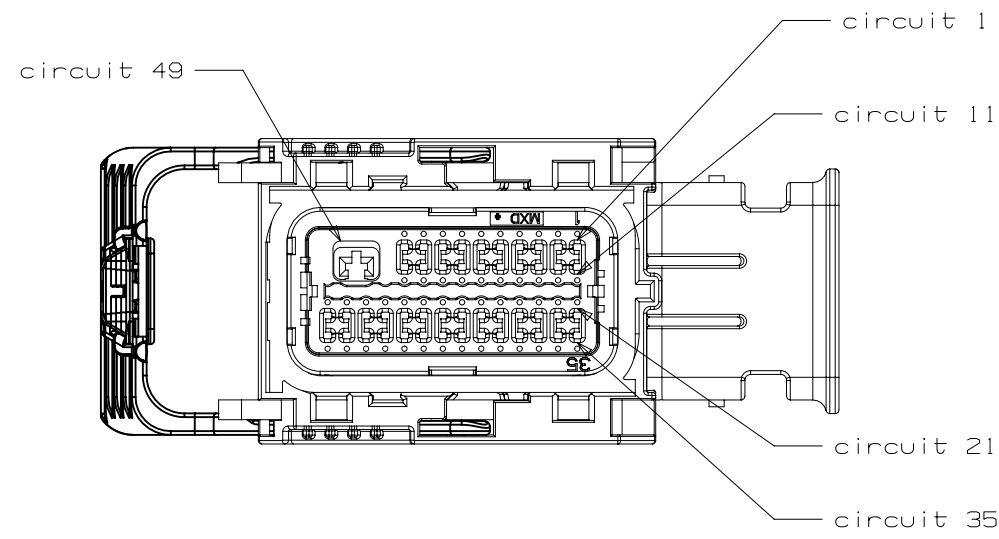

49 CKT HARNESS CONNECTOR ASSEMBLY
WIRE DRESS OPTION 0

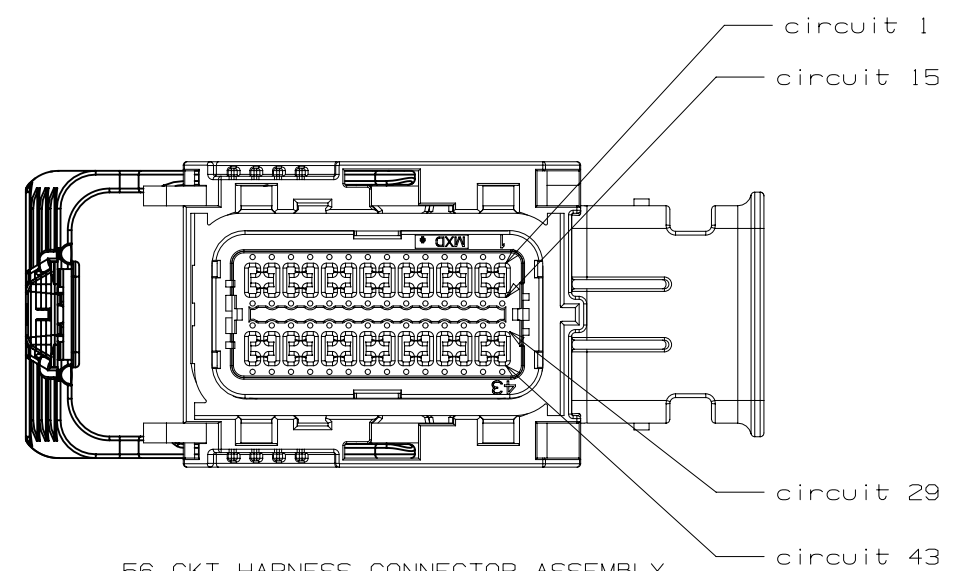

56 CKT HARNESS CONNECTOR ASSEMBLY
WIRE DRESS OPTION 0

INTERFACE SIDE SHOWN ON ALL VIEWS

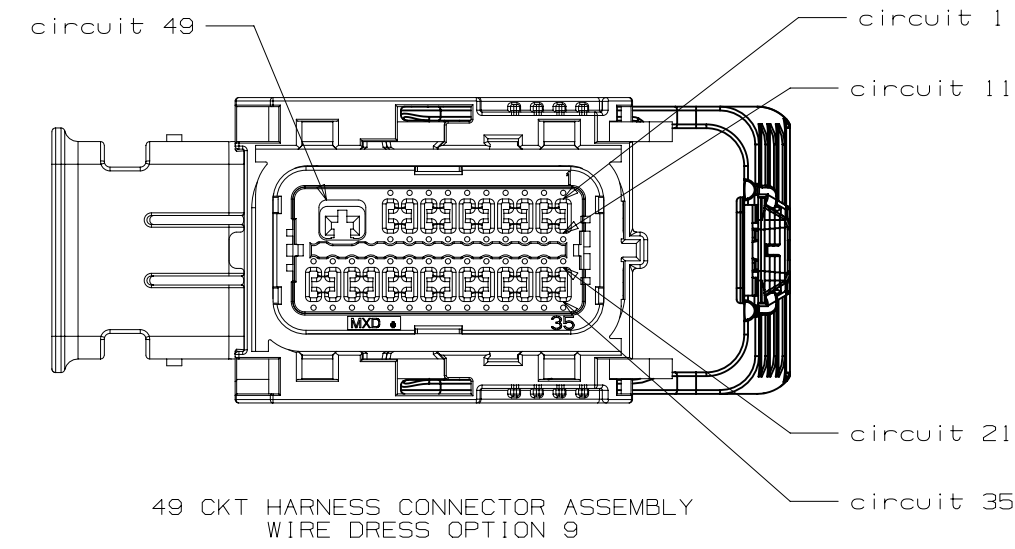

49 CKT HARNESS CONNECTOR ASSEMBLY
WIRE DRESS OPTION 9

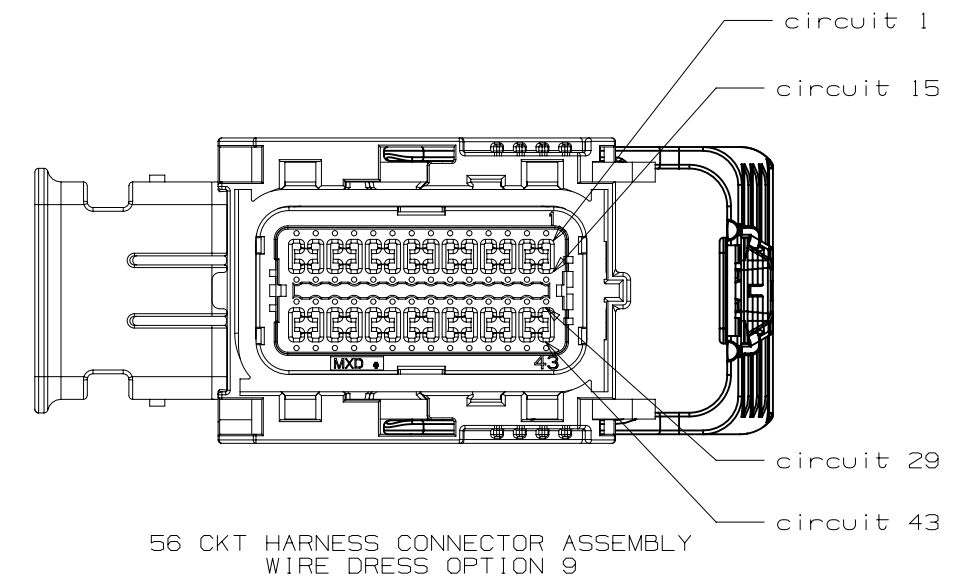

56 CKT HARNESS CONNECTOR ASSEMBLY
WIRE DRESS OPTION 9

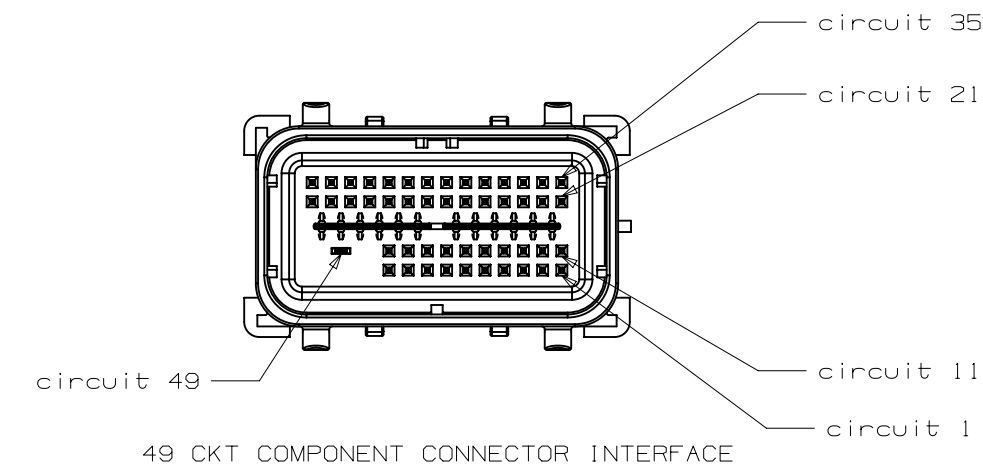

49 CKT COMPONENT CONNECTOR INTERFACE

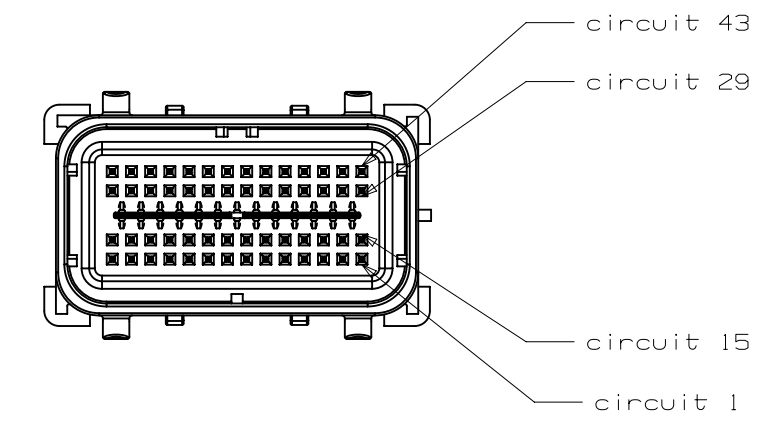

56 CKT COMPONENT CONNECTOR INTERFACE

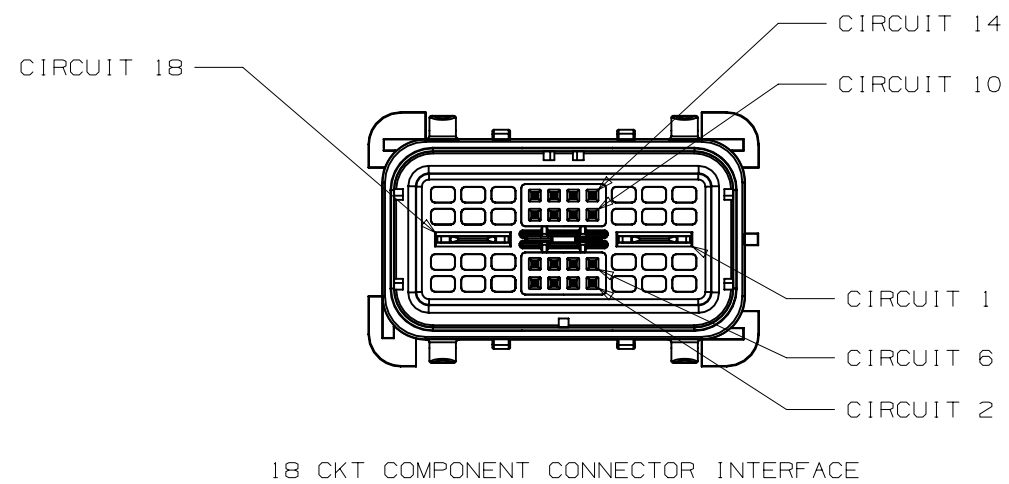
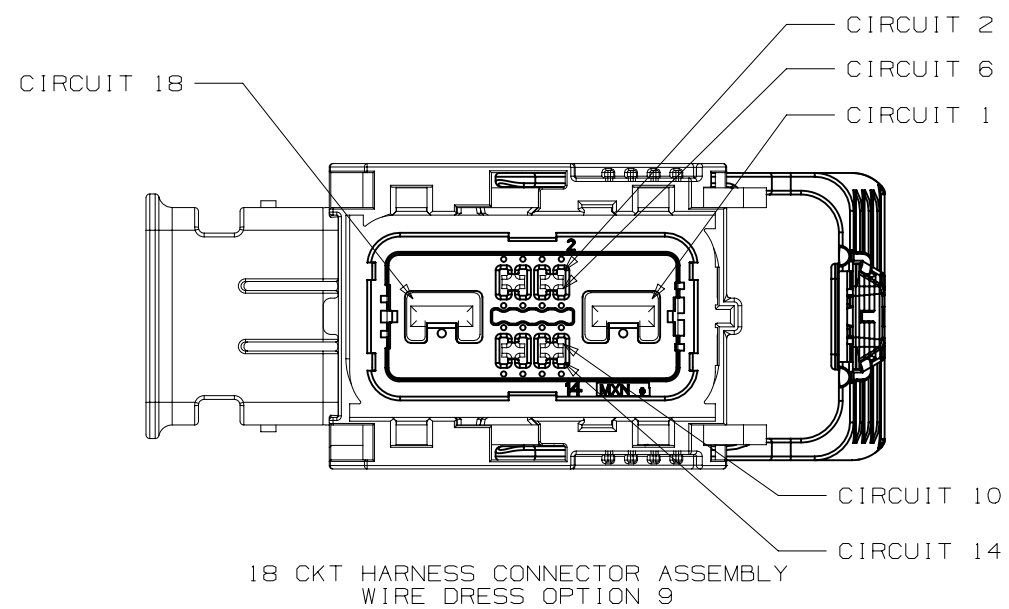
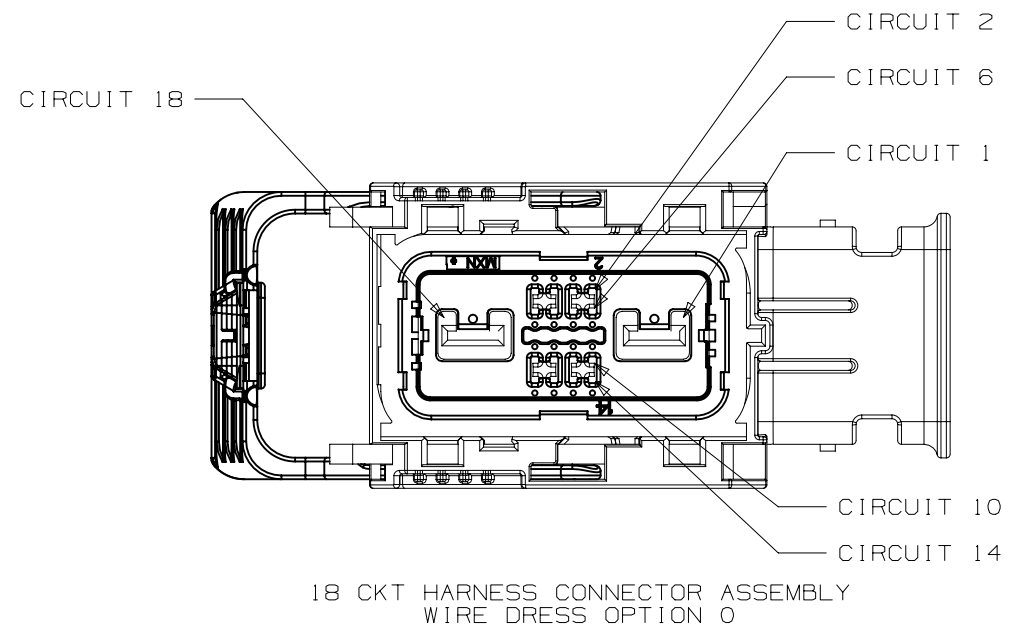

INTERFACE SIDE SHOWN ON ALL VIEWS



PAGE TITLE
CIRCUIT CONFIGURATIONS

DRAWING NUMBER
12642694

DWG STATUS			PAGE NUMBER	
ST	REV	PDI	14	OF 22
R	001			

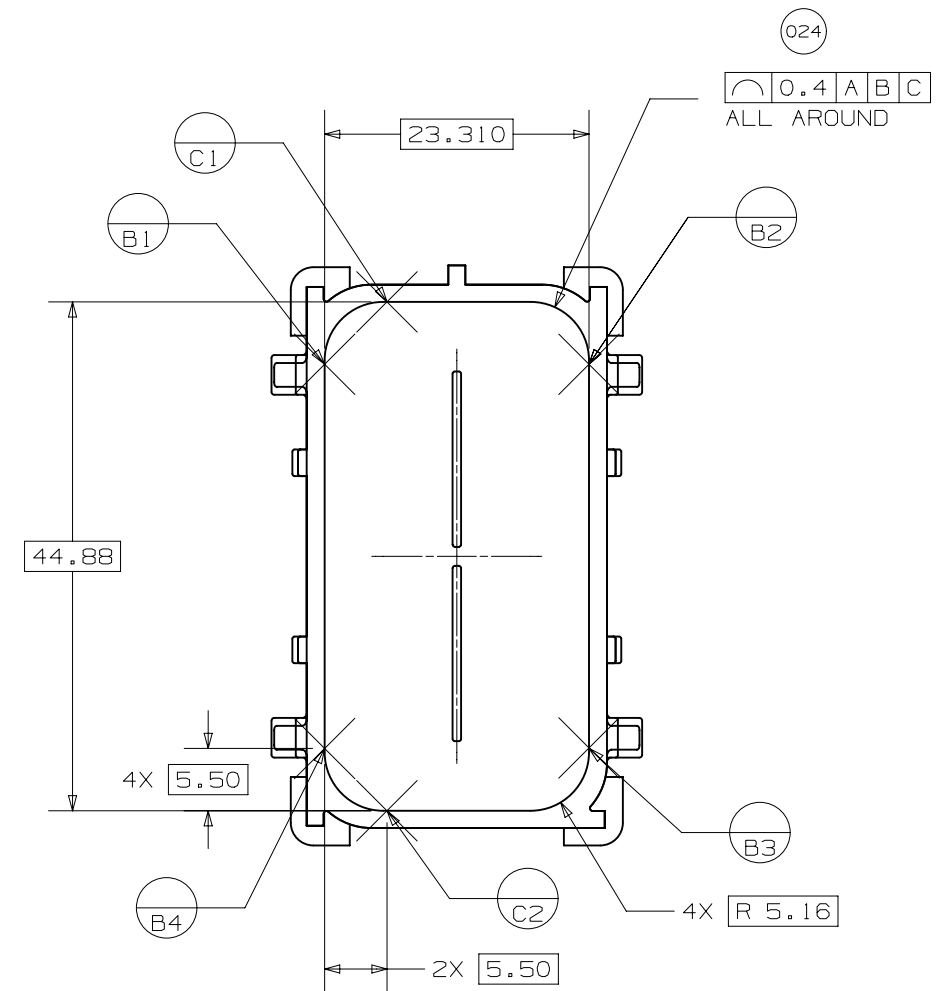
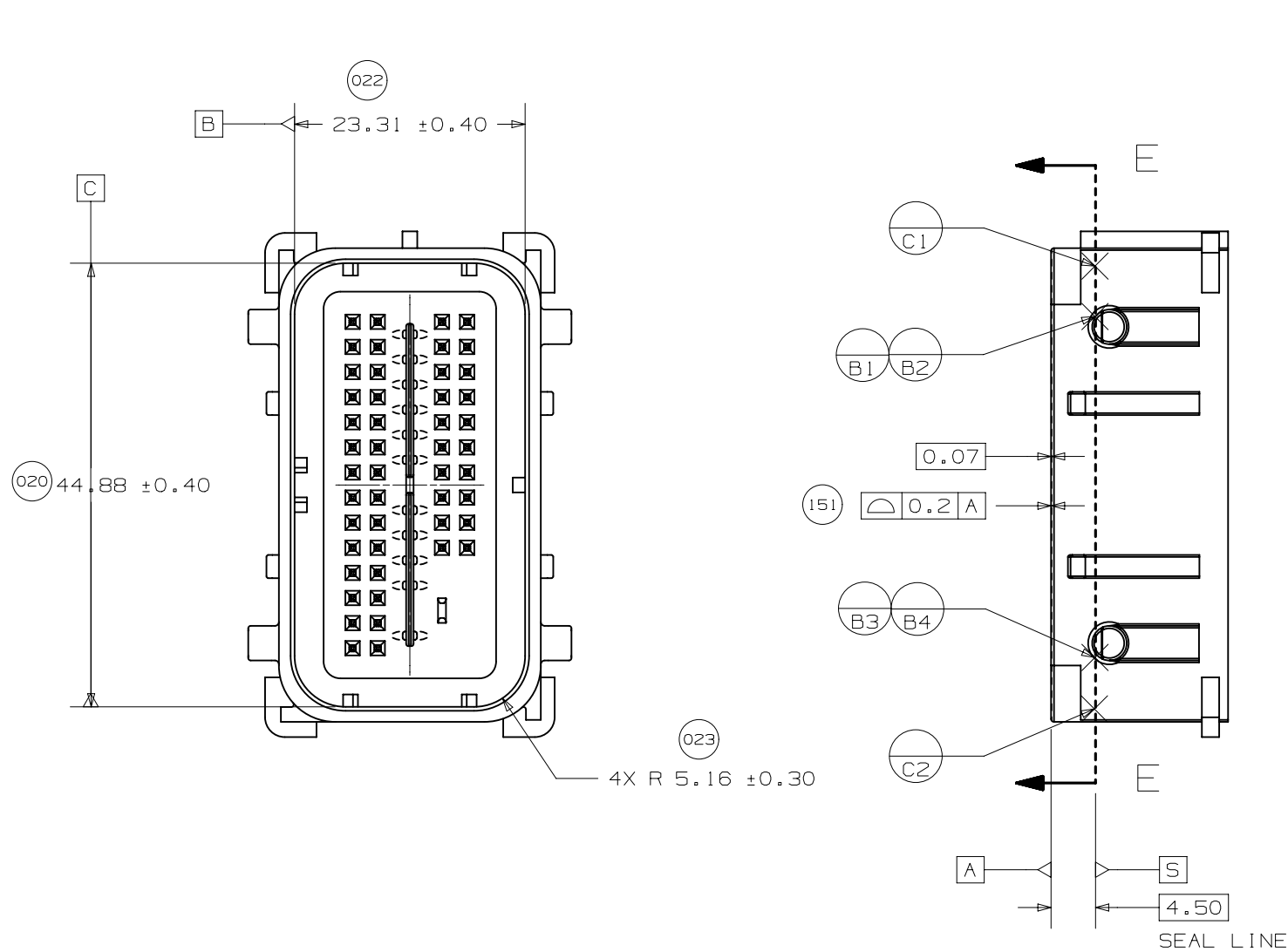
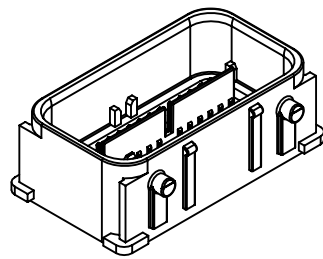

SECTION E-E
(AT SEAL LINE)

UNLESS SPECIFIED, TOLERANCE OF THE DEVICE INTERFACE TO BE $\triangle 0.13$ A B C



PAGE TITLE
COMPONENT CONNECTOR INTERFACE

DRAWING NUMBER
12642694

DWG STATUS			PAGE NUMBER
ST	REV	PD1	
R	001		15 of 22

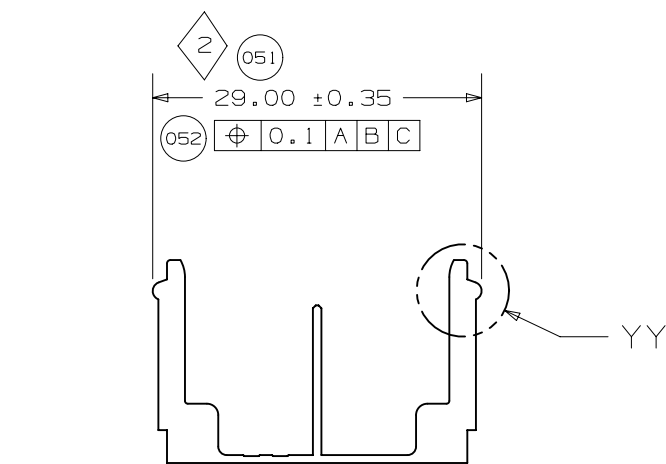
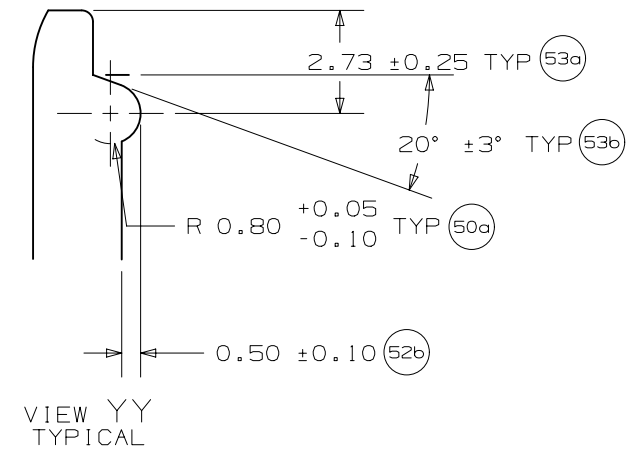
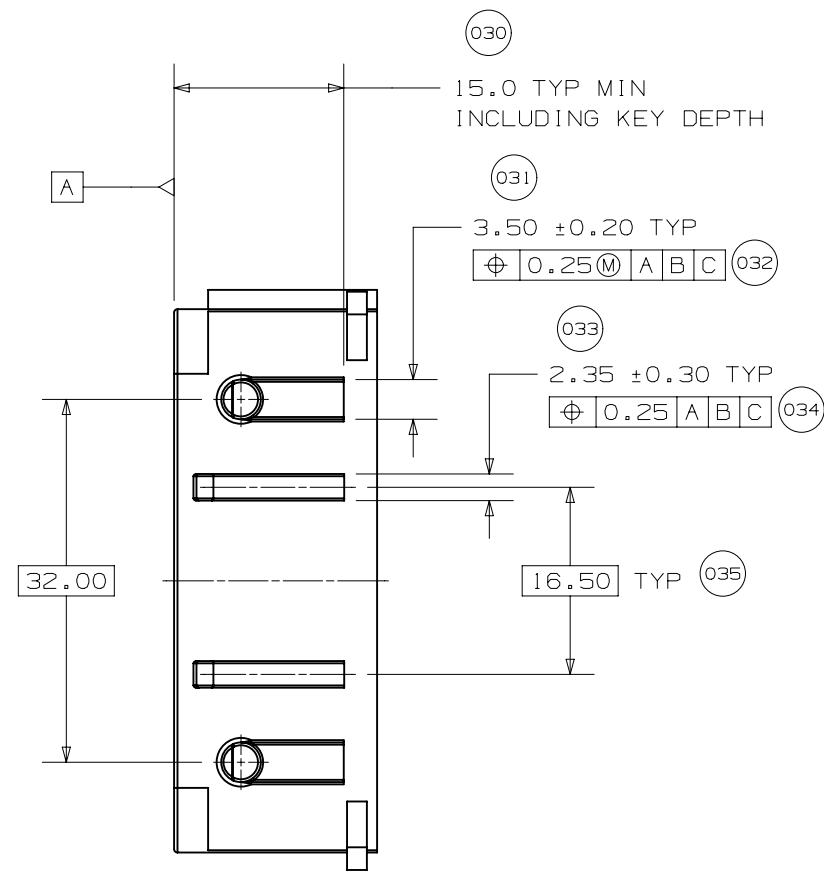
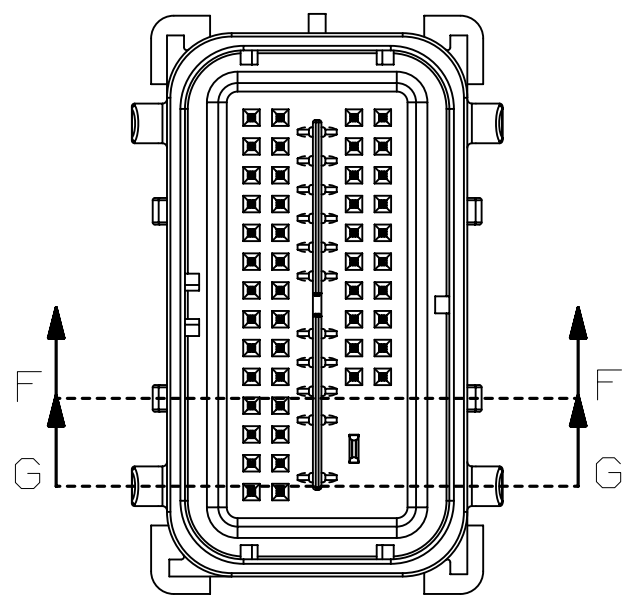

SECTION F - F
(RELEASE FEATURE)

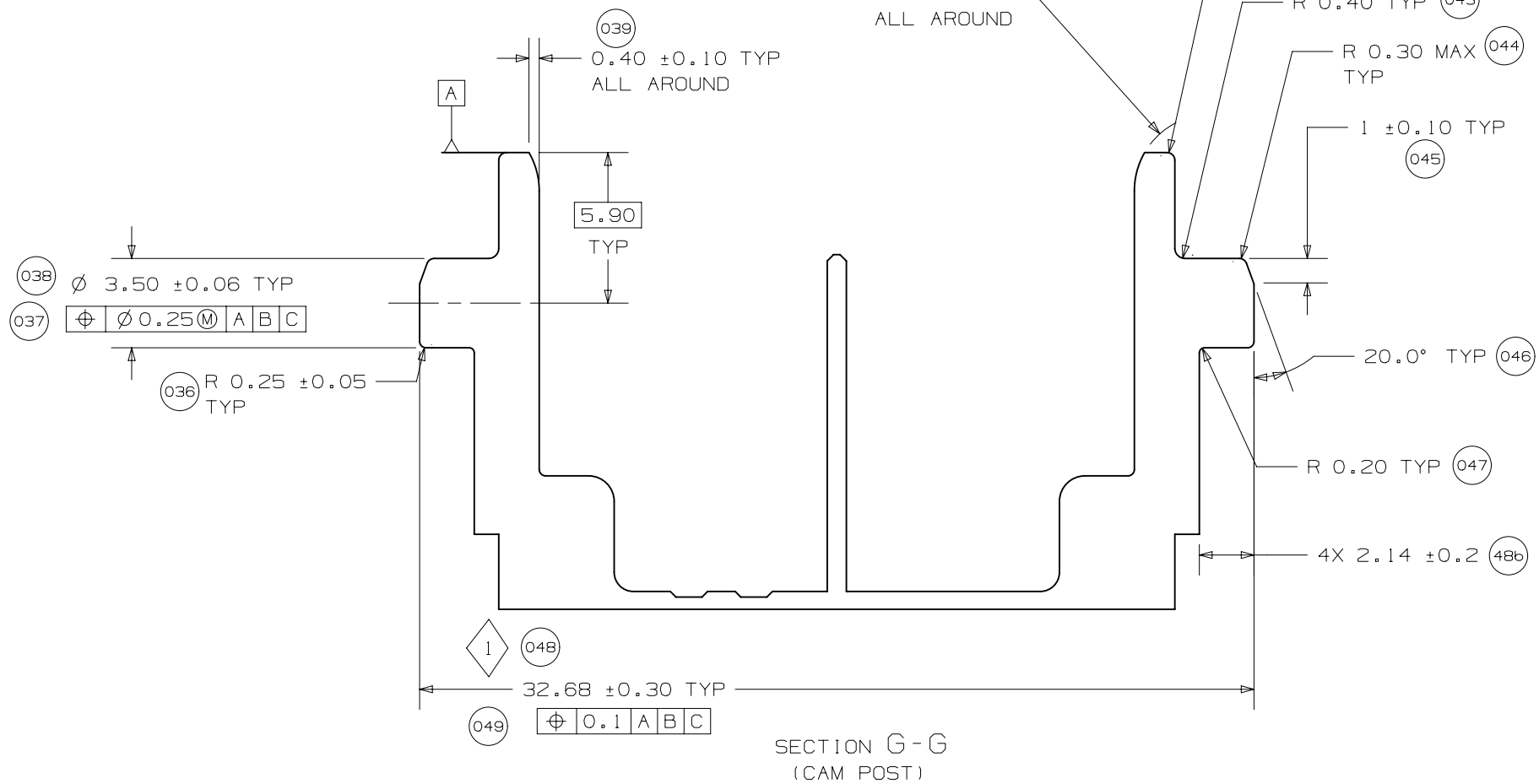

SECTION G - G
(CAM POST)



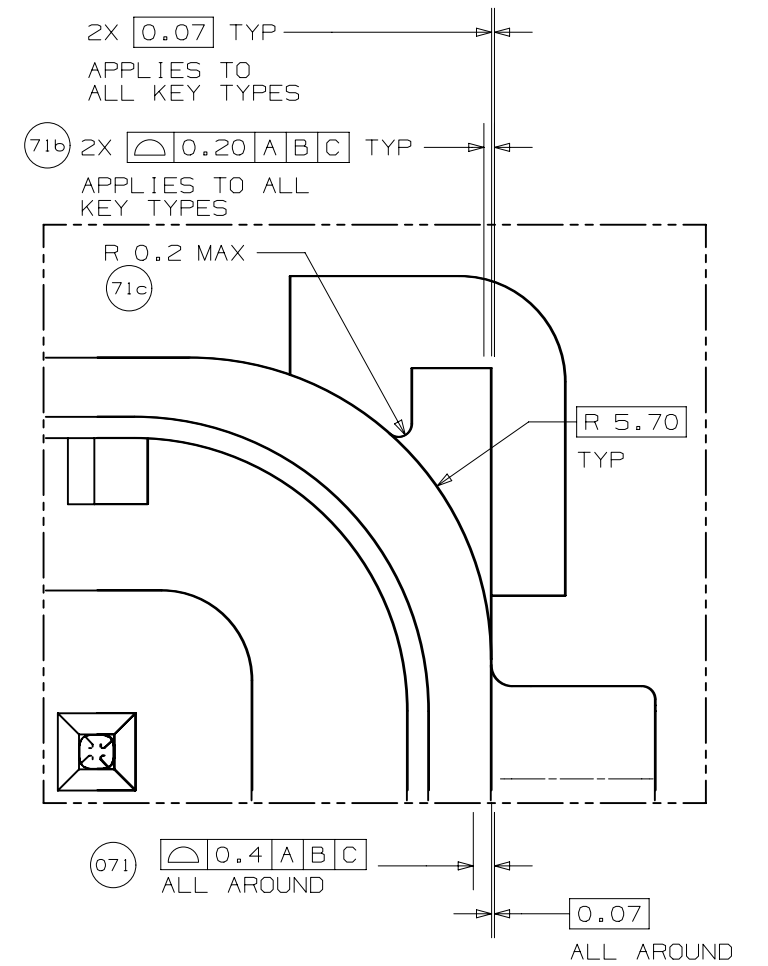
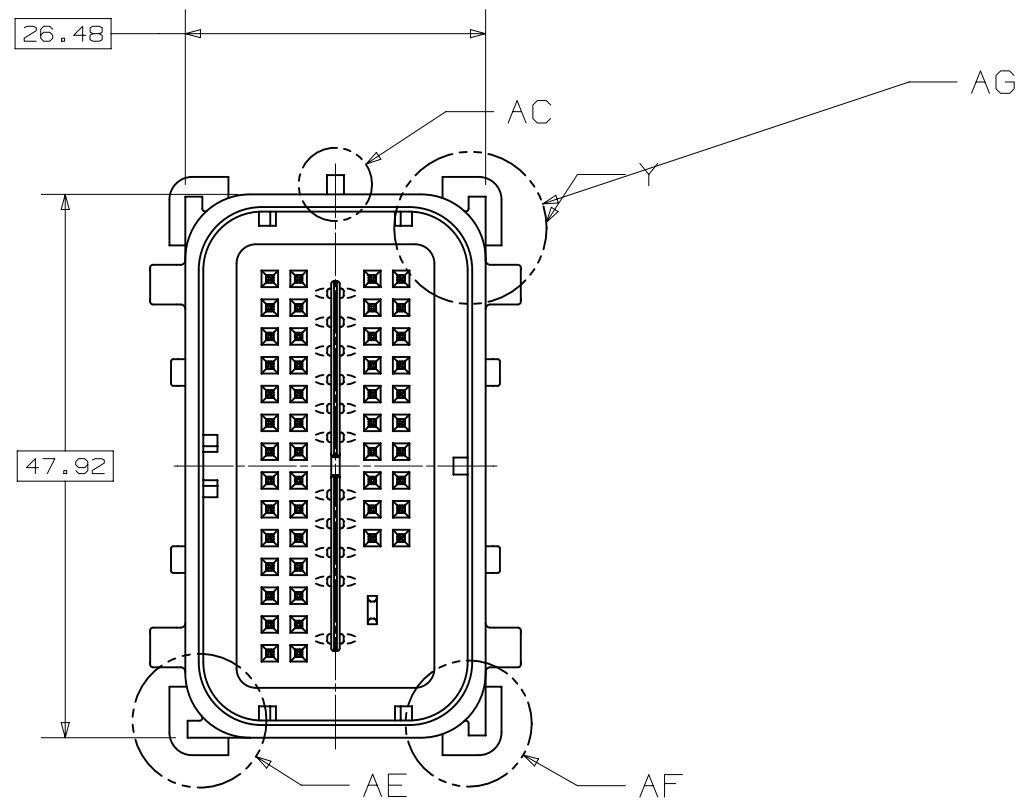
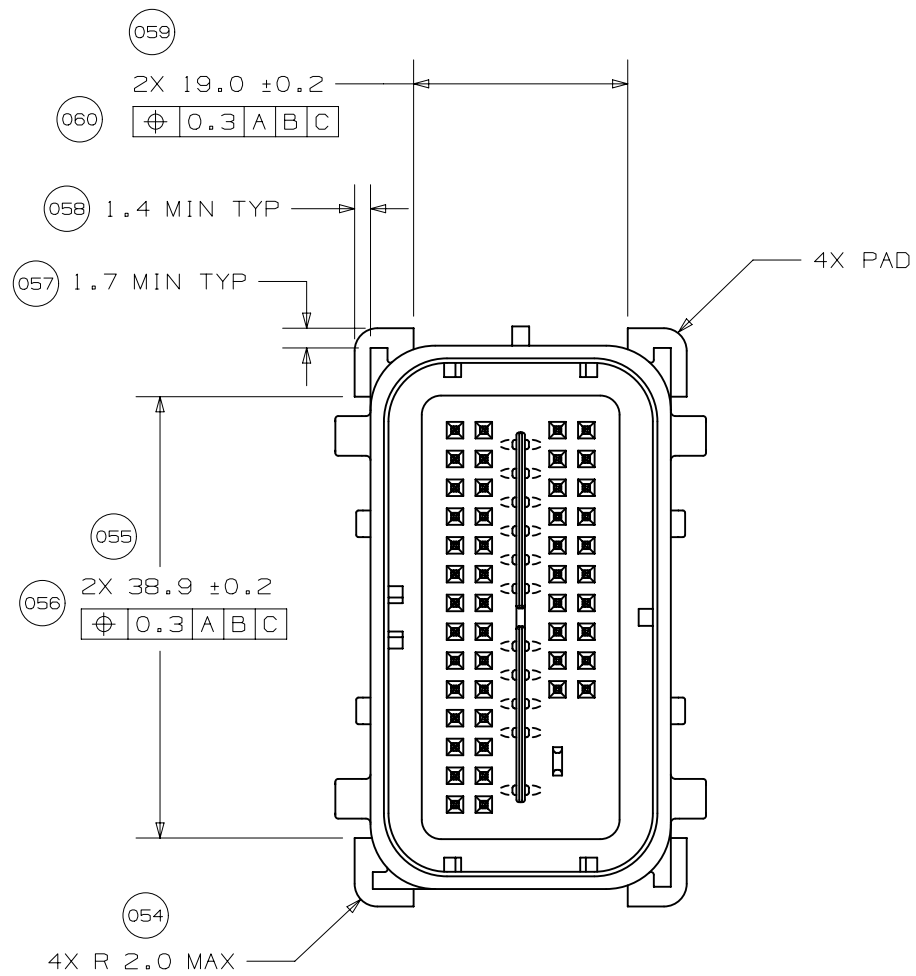

DETAIL Y
SCALE 7:1

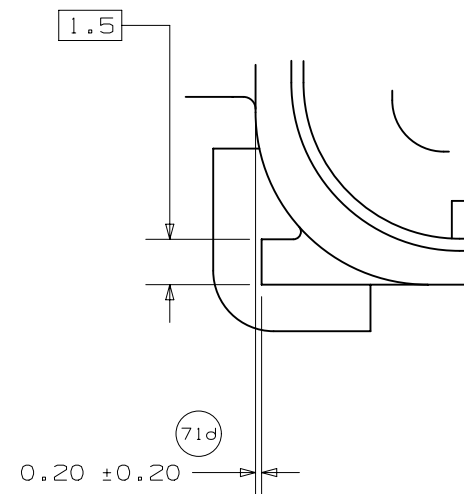
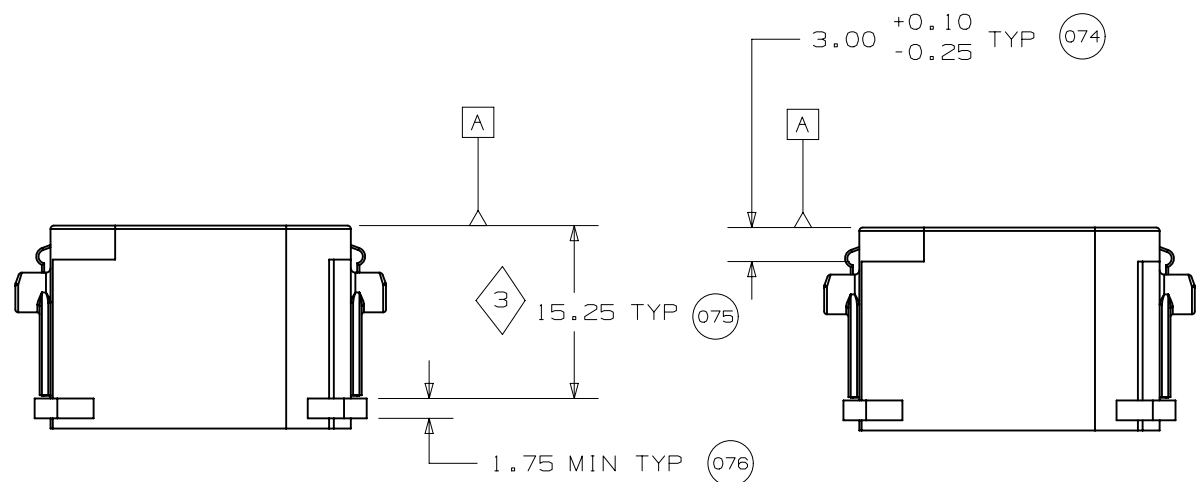

VIEW AE
KEY TYPE 2

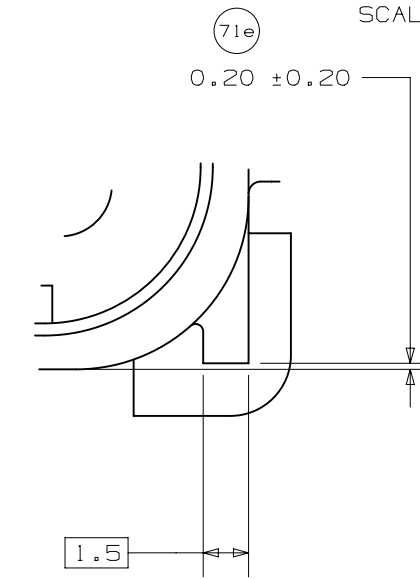

VIEW AF
KEY TYPE 1

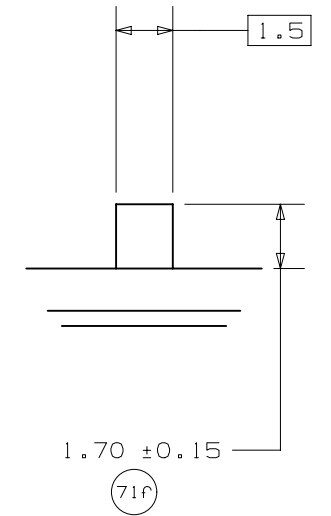

VIEW AC
KEY TYPE 3



PAGE TITLE
COMPONENT CONNECTOR INTERFACE

DRAWING NUMBER
12642694

DWG STATUS			PAGE NUMBER
ST	REV	PD1	
R	001		17 of 22

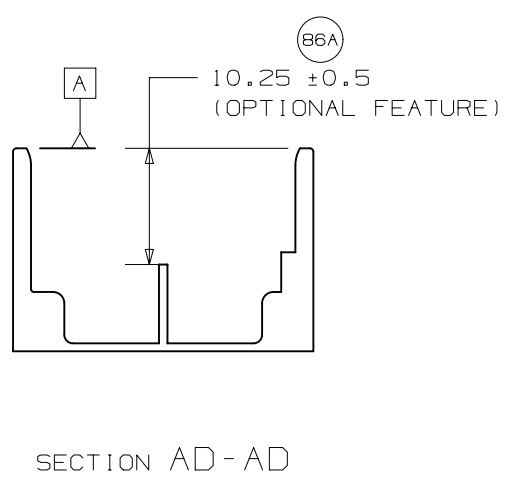
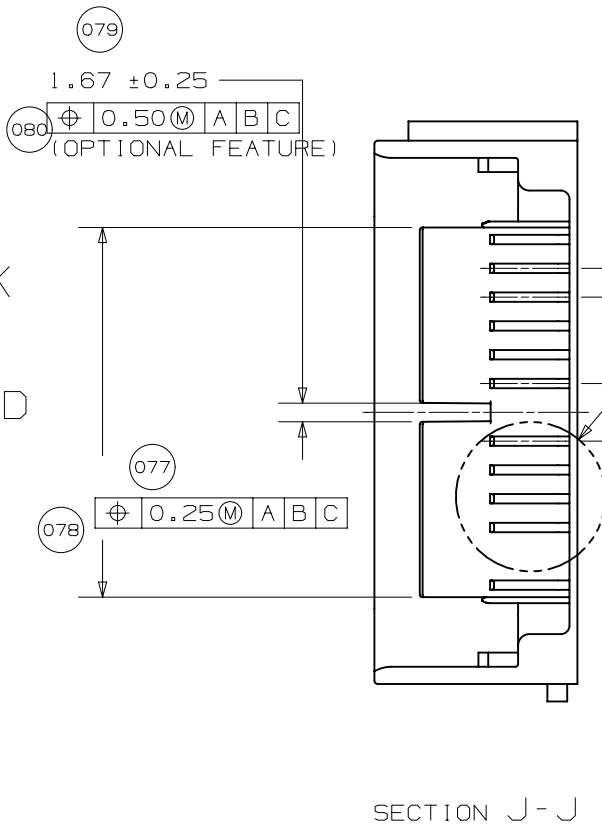
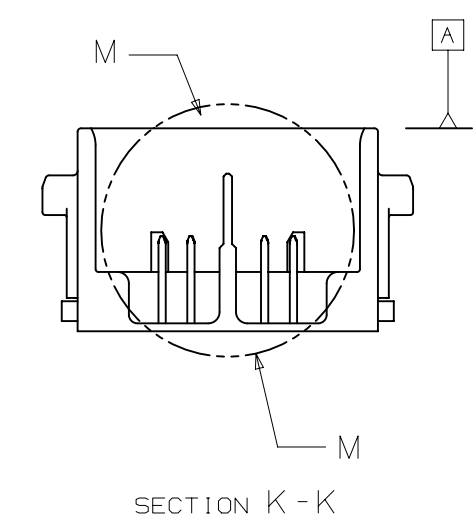
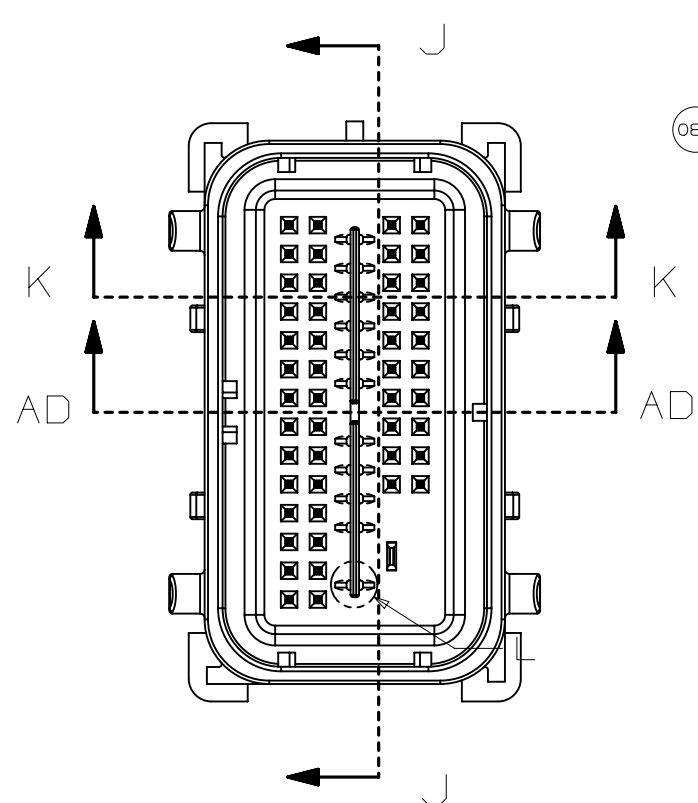

CKT	DIM 077
49 / 56 CKT	32.60 +0.10/-0.80
18 CKT	10.04 +0.10/-0.80

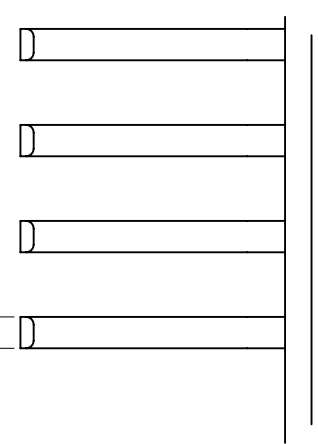
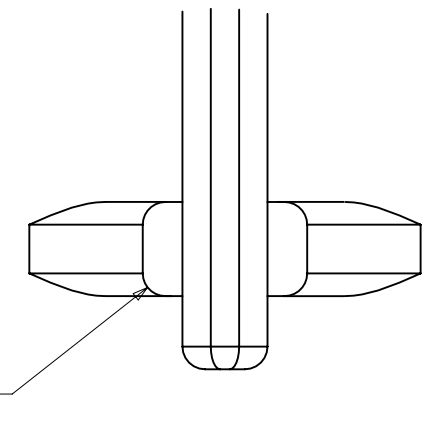
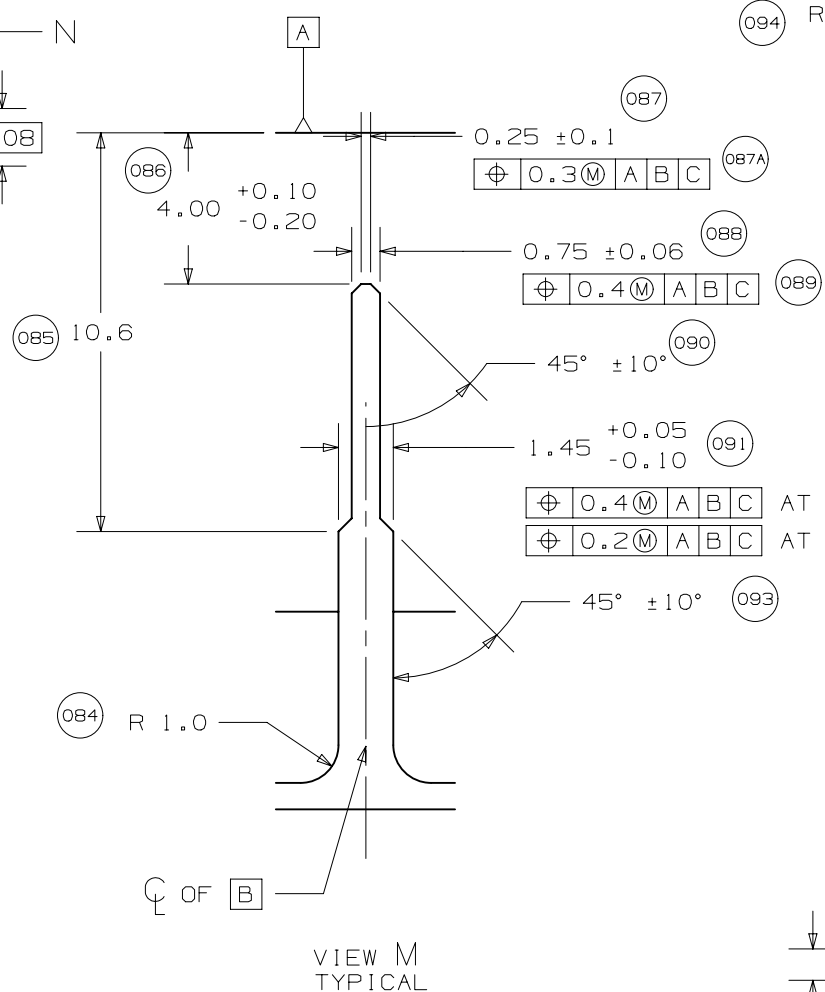

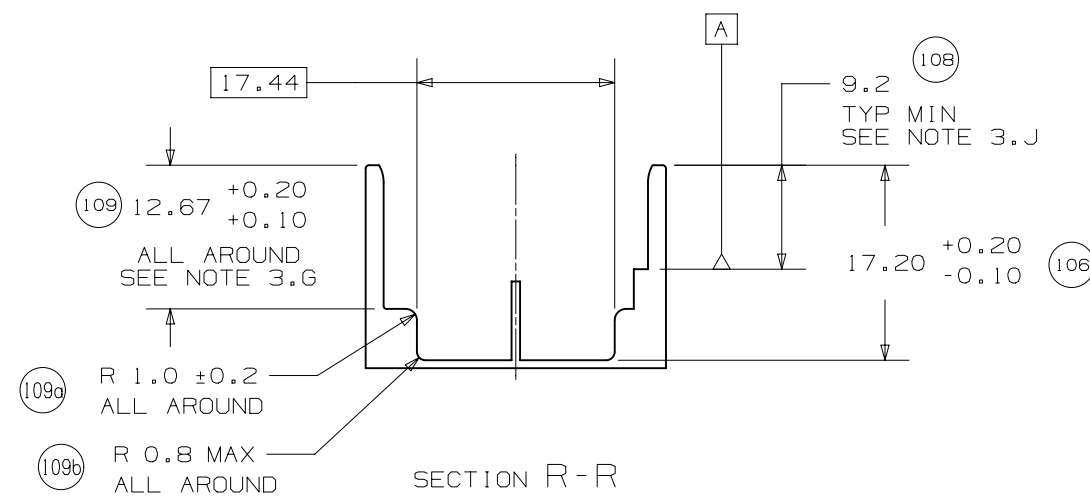
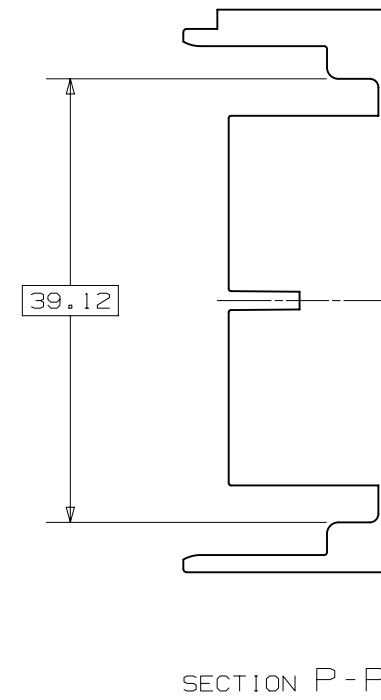
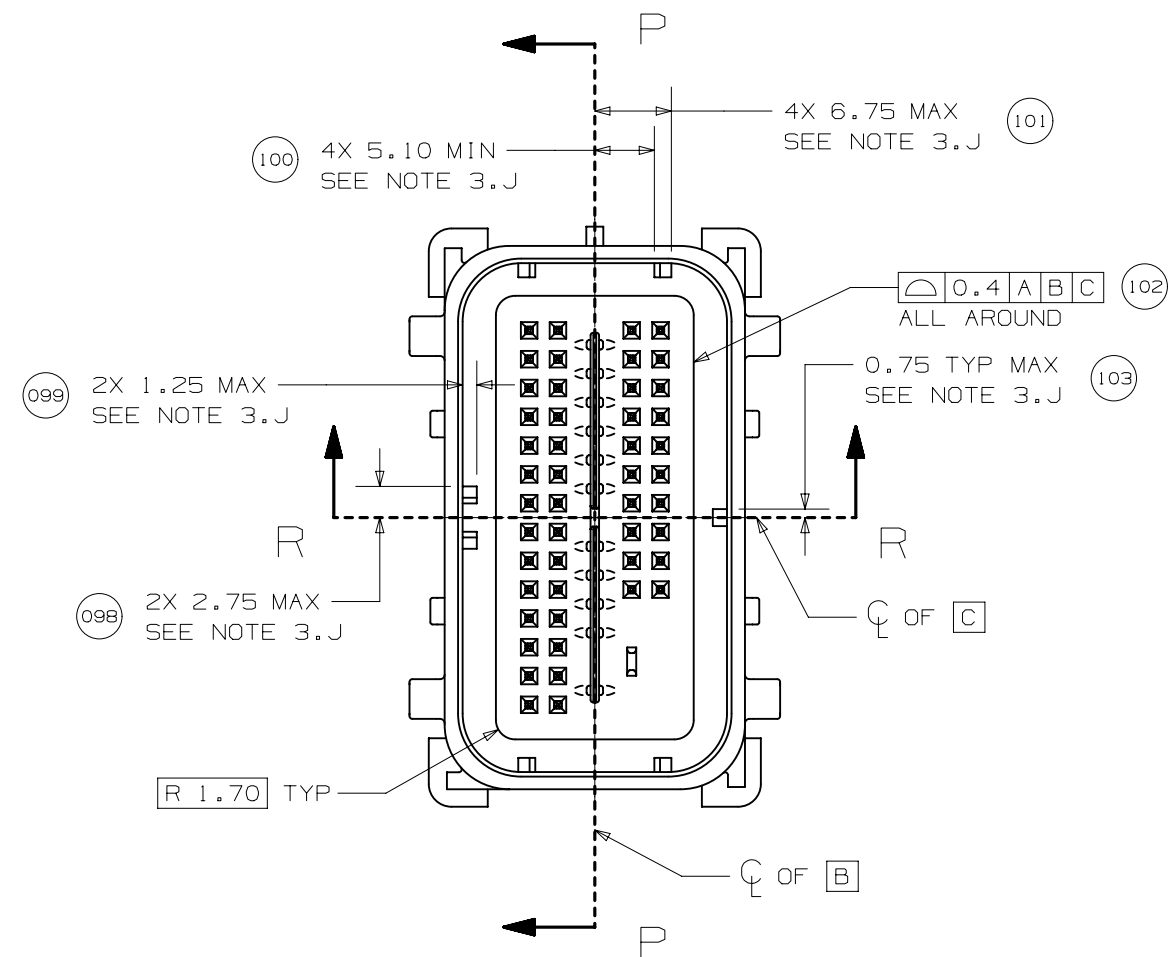

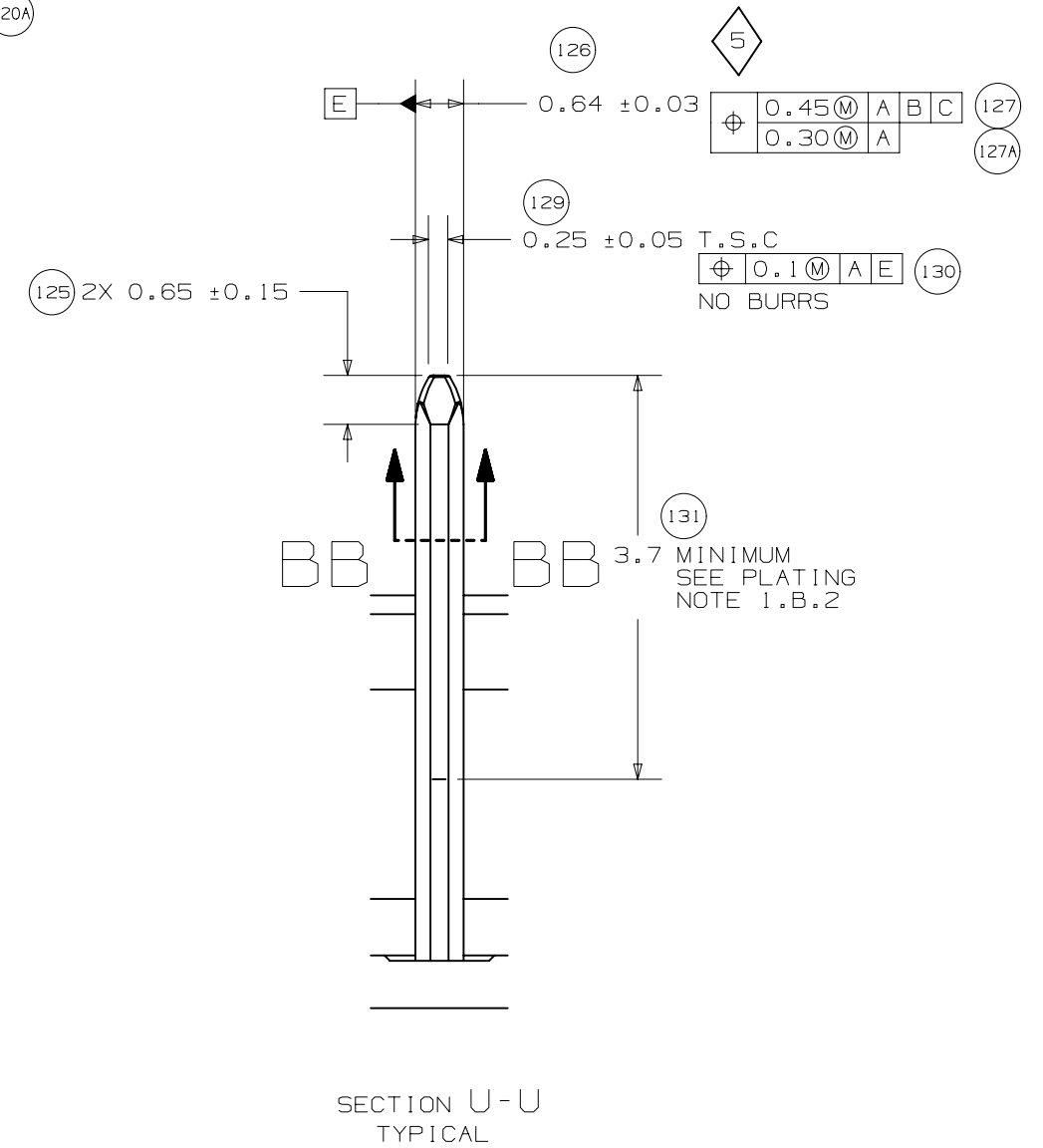
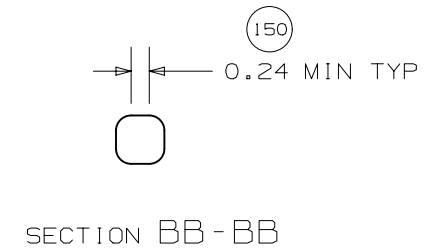
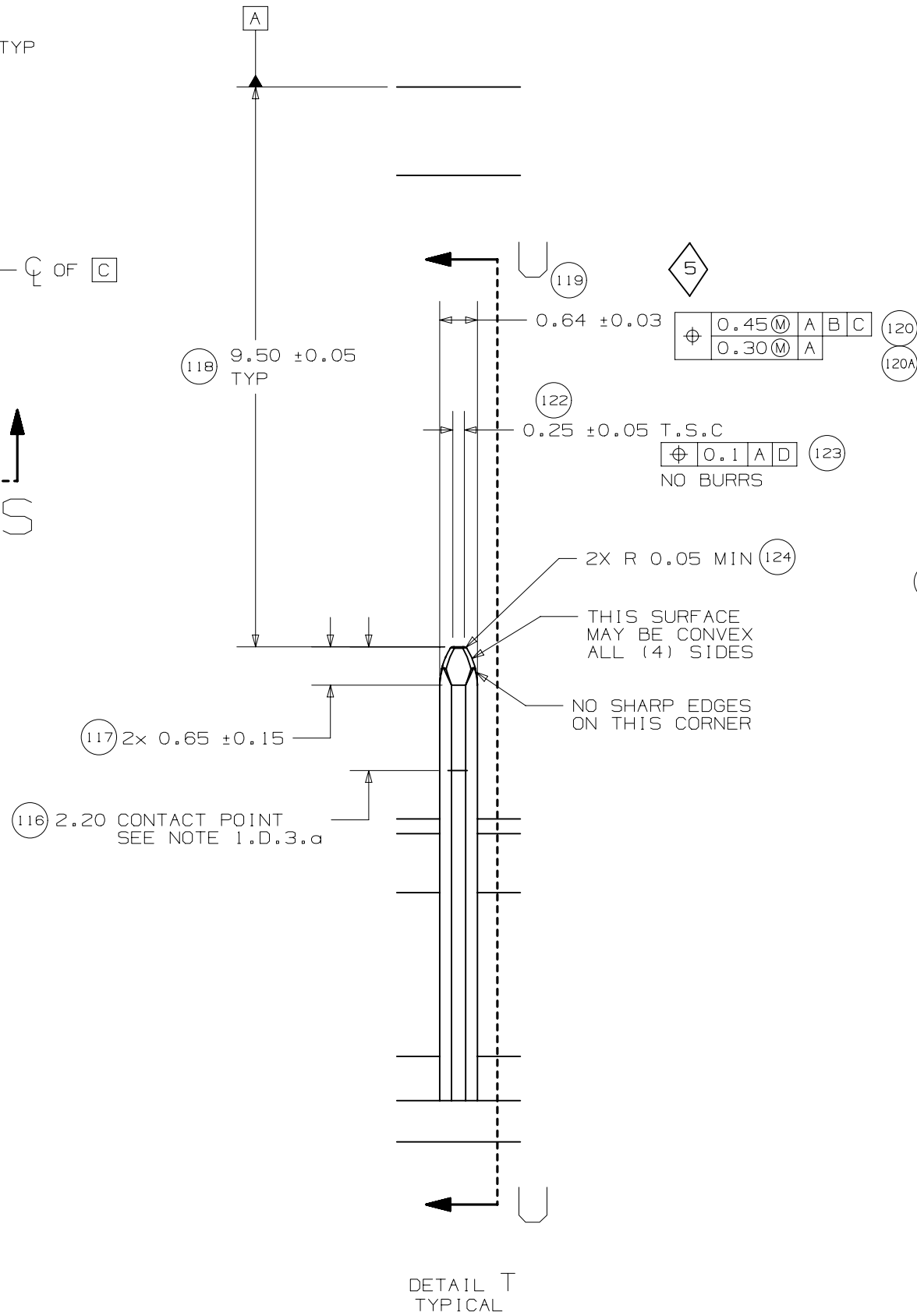
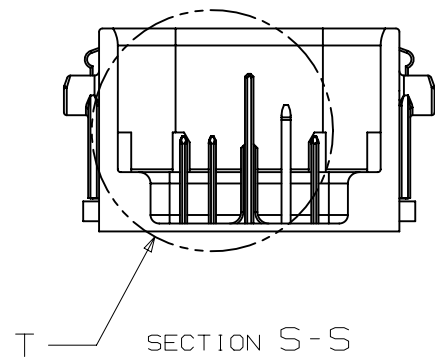
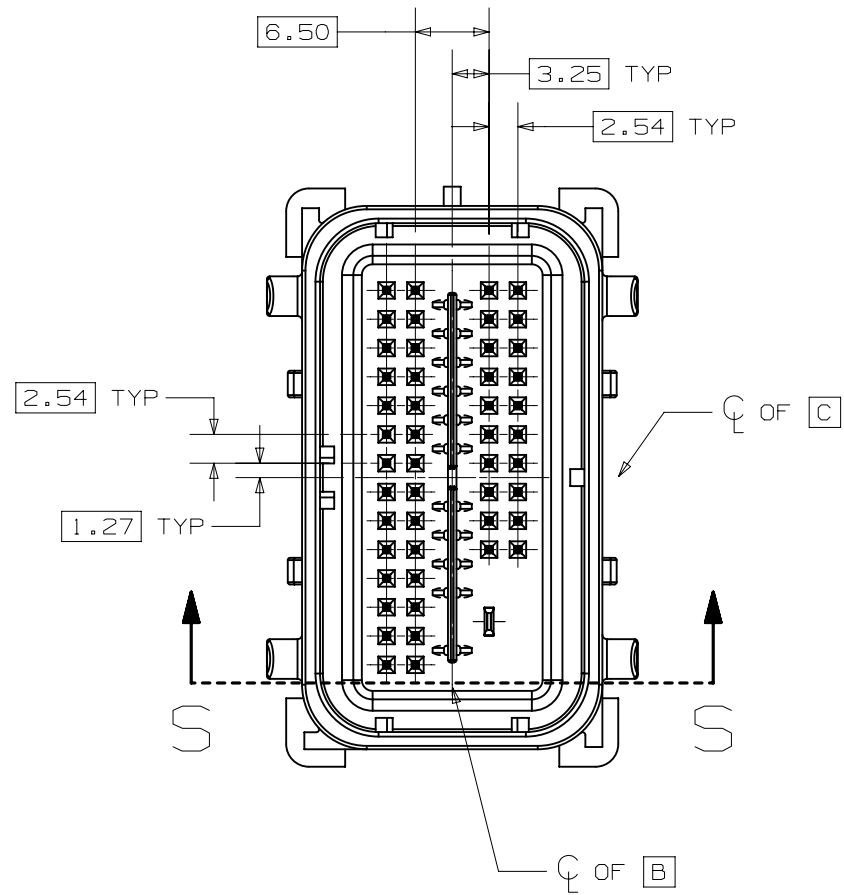

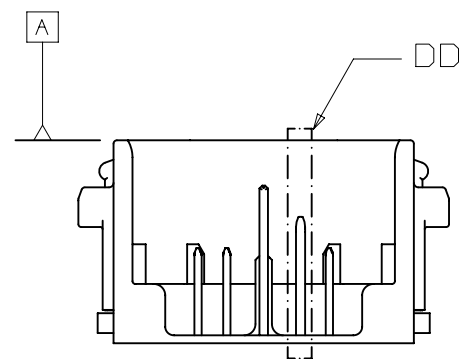
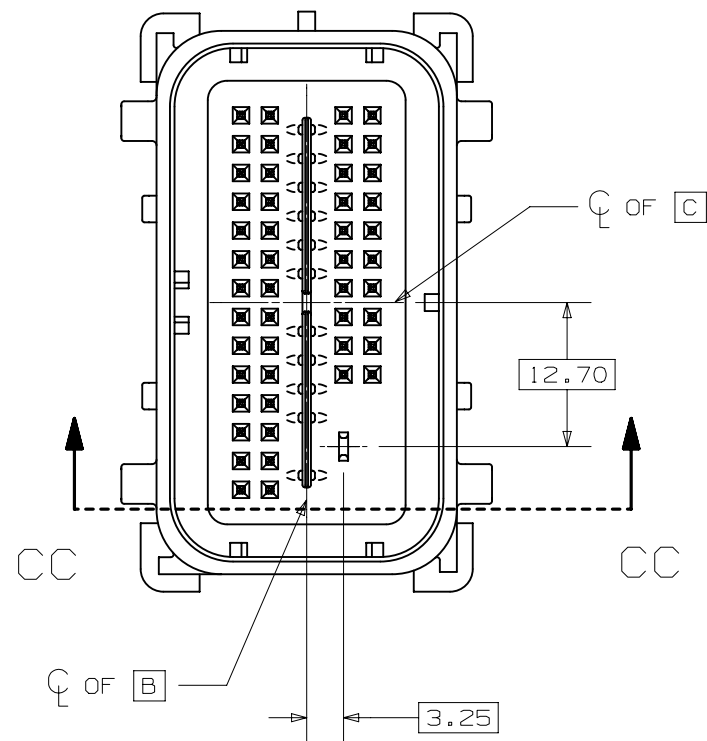

SECTION CC-CC

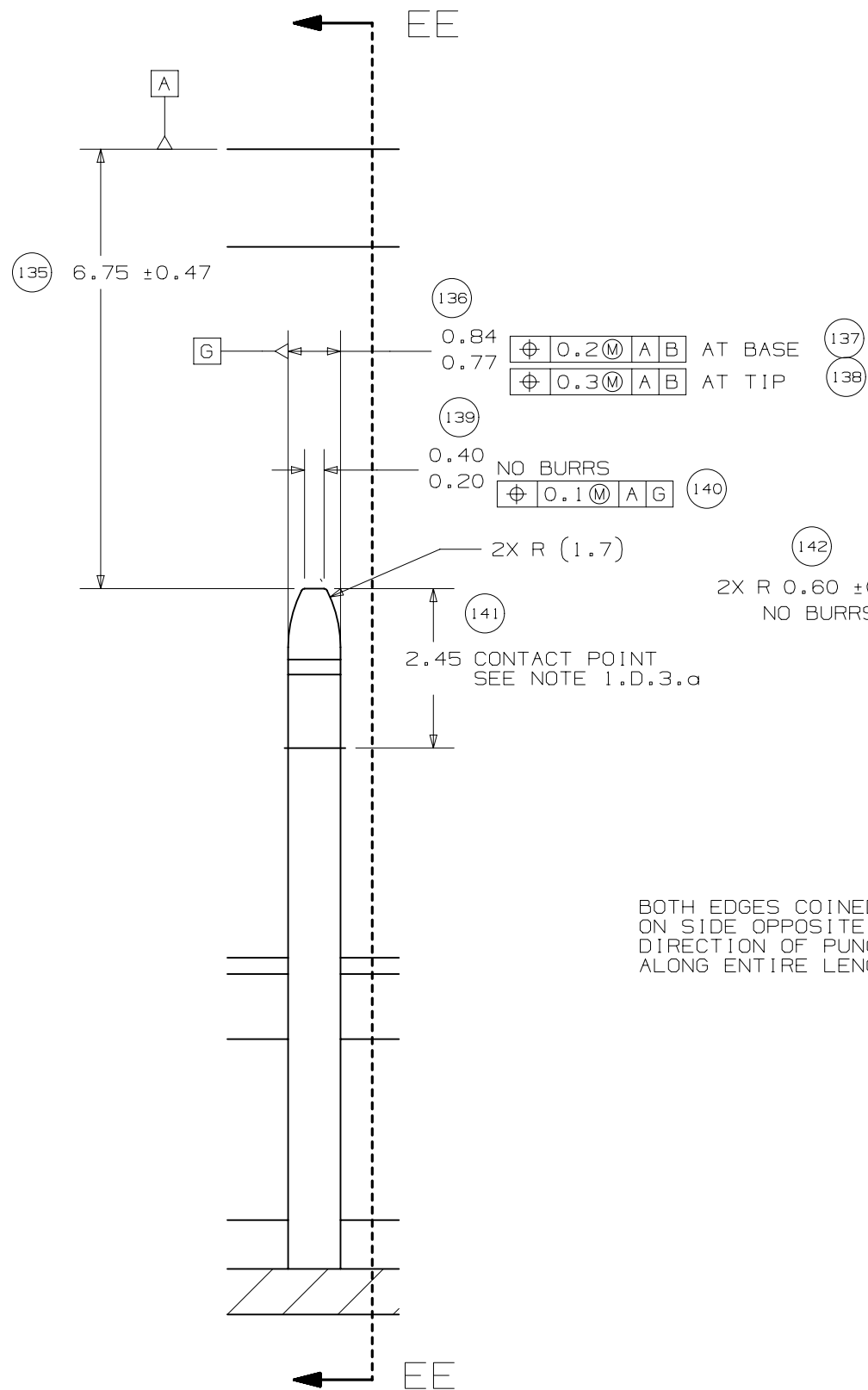

DETAIL DD
TYPICAL

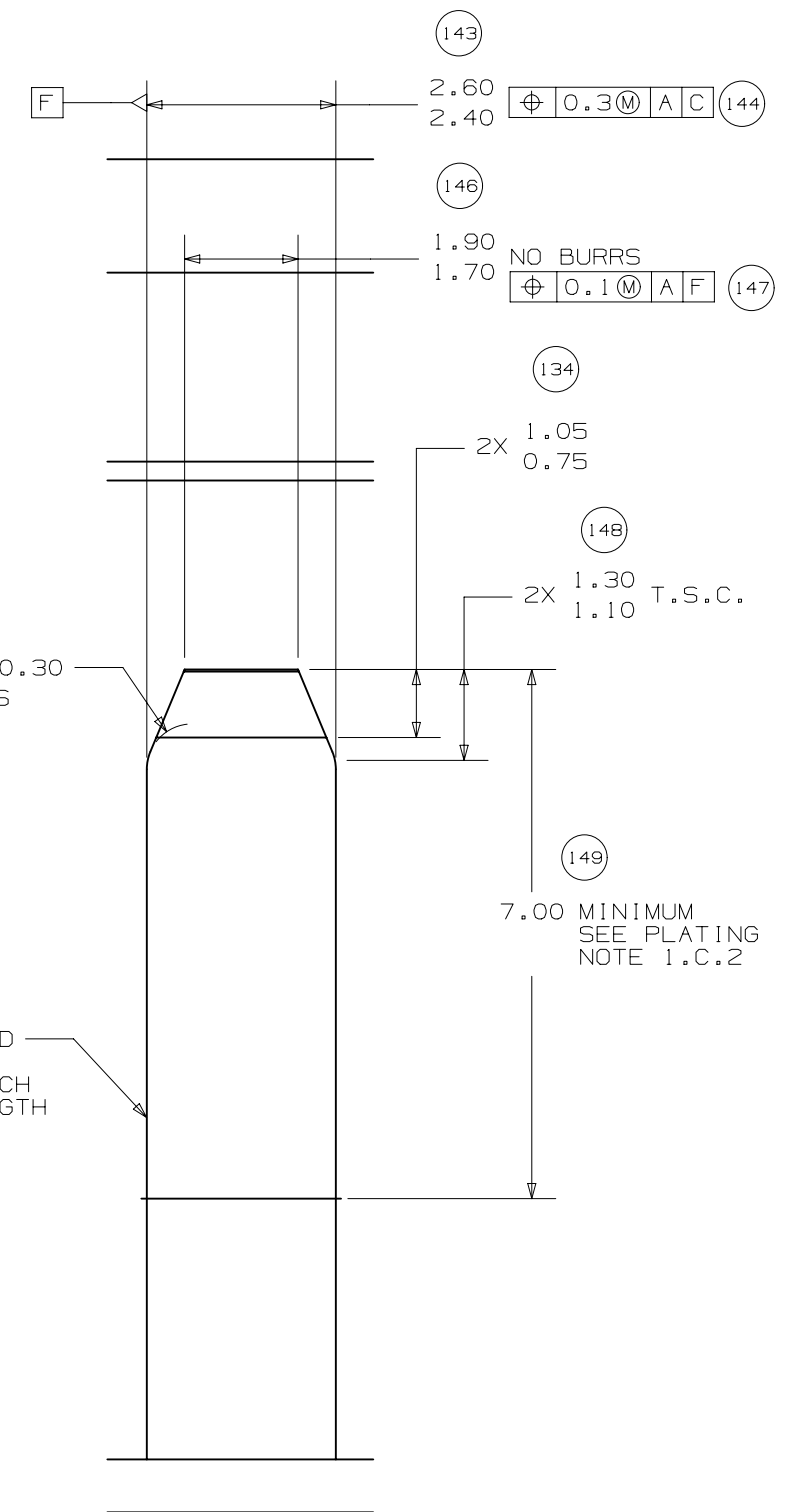

SECTION EE-EE
TYPICAL



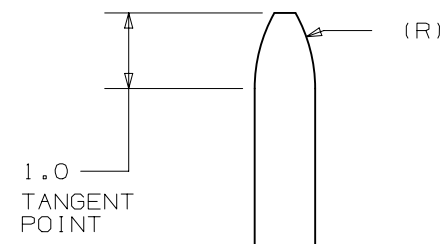

VIEW CA
SCALE 10:1

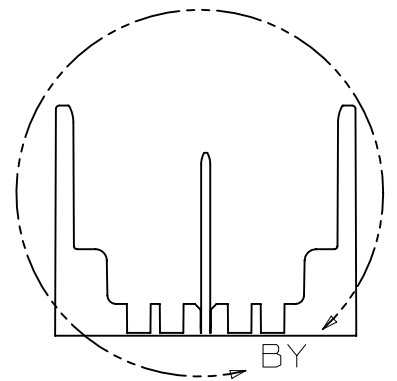
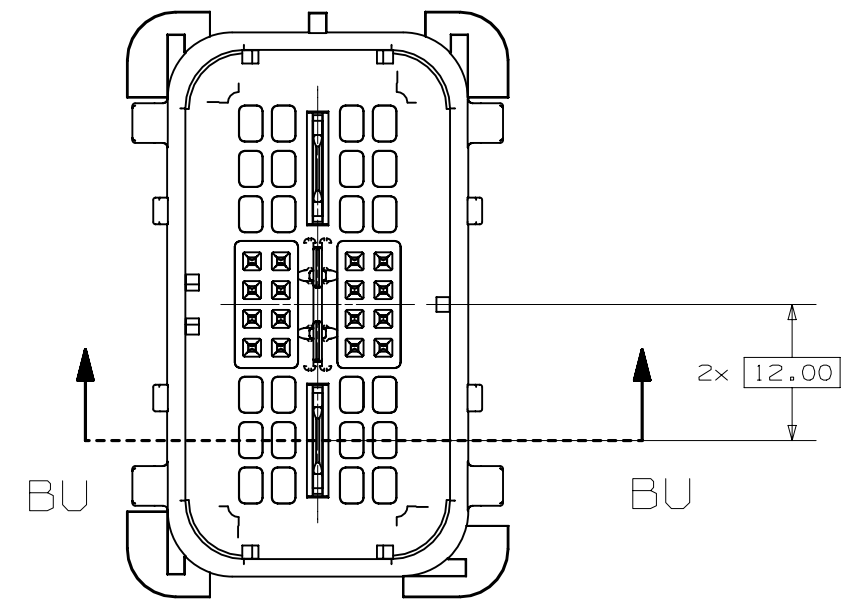

SECTION BU-BU

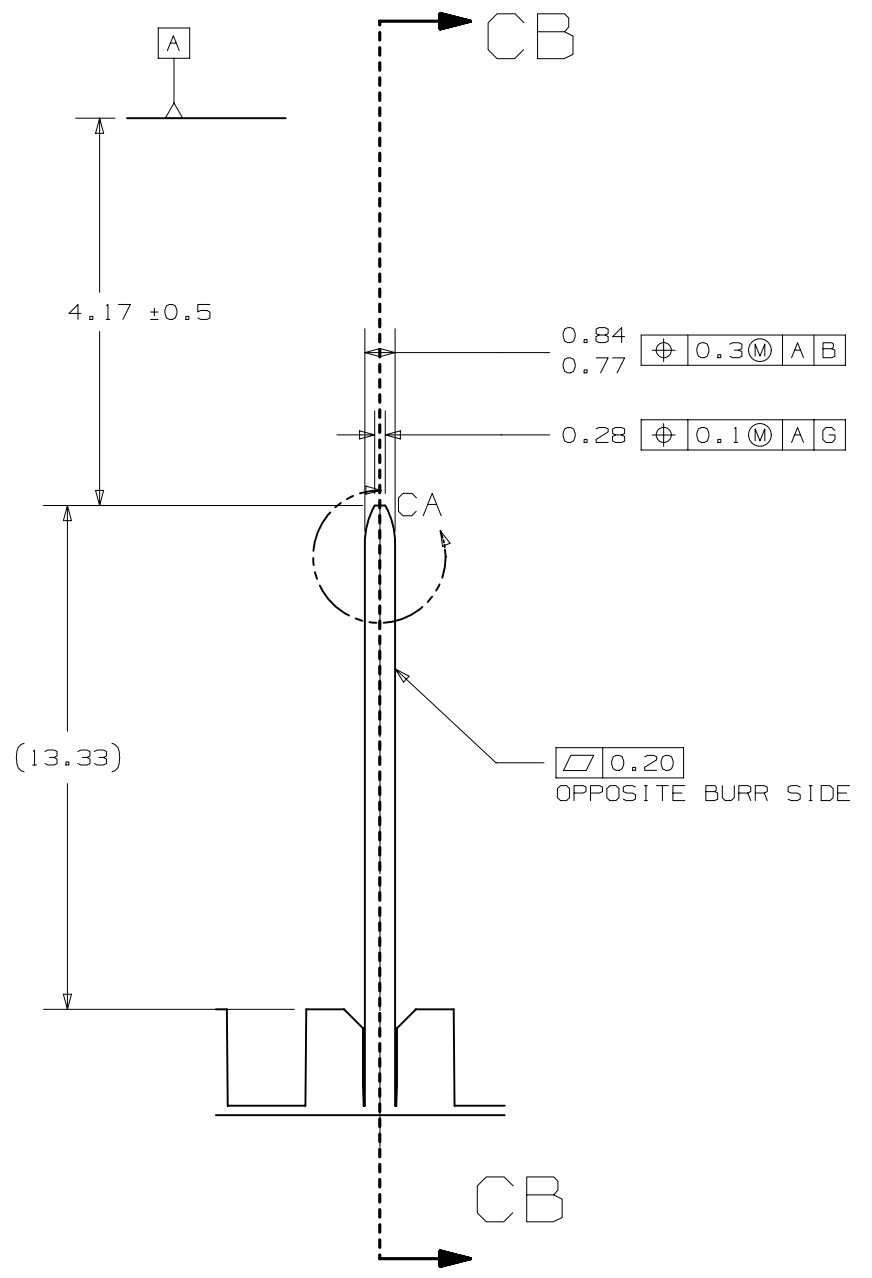

VIEW BY
SCALE 5:1

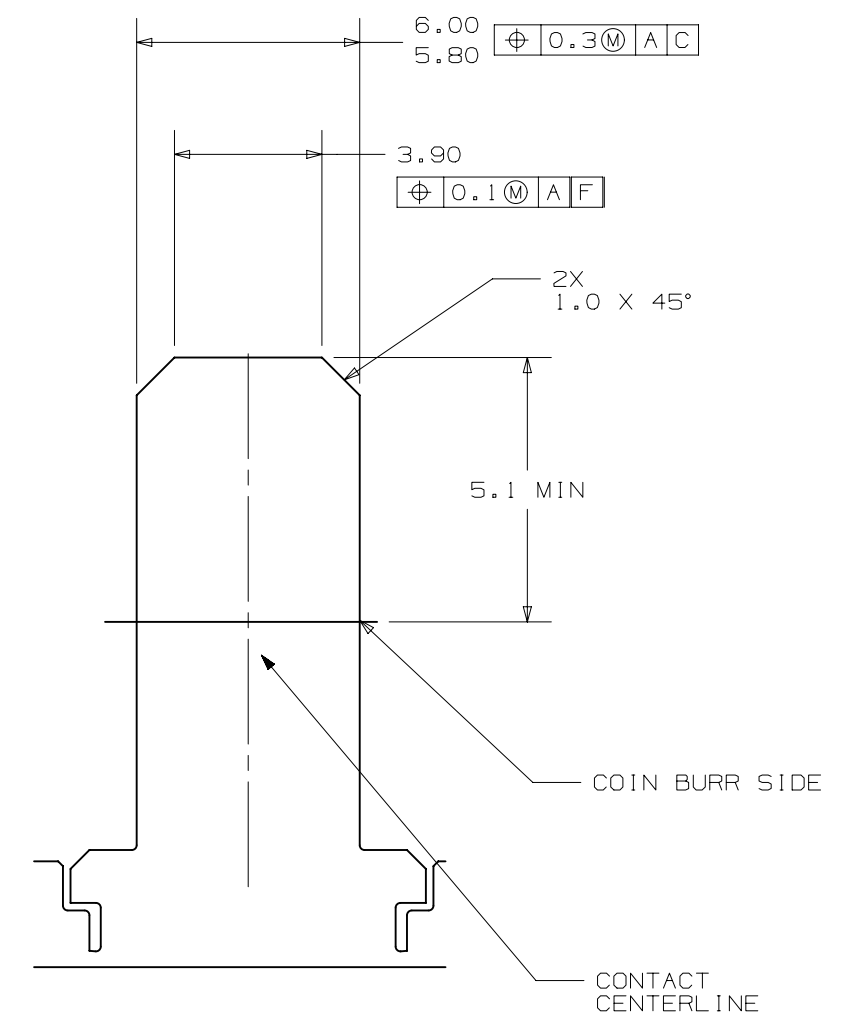

SECTION CB-CB

GM	PAGE TITLE	DRAWING NUMBER	DWG STATUS			PAGE NUMBER	
	COMPONENT CONNECTOR INTERFACE		12642694	ST	REV	PD1	22 of 22
				R	001		



MX123 18/28/42/49/56-WAY RECEPTACLE ASSY SEALED PIN OUT SHEET

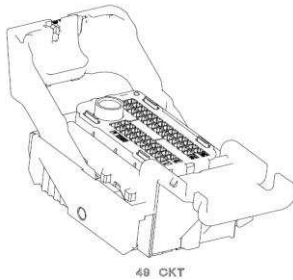

48 CKT

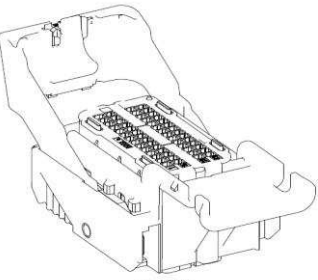

56 CKT

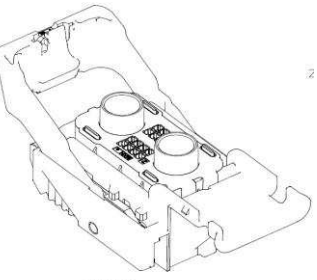

18 CKT

UNCHECKED cavity number(s) are OPEN

56	55	54	53	52	51	50	49	48	47	46	45	44	43
<input type="checkbox"/>	<input type="checkbox"/>	<input type="checkbox"/>	<input type="checkbox"/>	<input type="checkbox"/>	<input type="checkbox"/>	<input type="checkbox"/>	<input checked="" type="checkbox"/>	<input checked="" type="checkbox"/>	<input checked="" type="checkbox"/>	<input checked="" type="checkbox"/>	<input type="checkbox"/>	<input checked="" type="checkbox"/>	<input checked="" type="checkbox"/>
42	41	40	39	38	37	36	35	34	33	32	31	30	29
<input type="checkbox"/>	<input type="checkbox"/>	<input type="checkbox"/>	<input type="checkbox"/>	<input checked="" type="checkbox"/>	<input checked="" type="checkbox"/>	<input checked="" type="checkbox"/>	<input type="checkbox"/>	<input type="checkbox"/>	<input checked="" type="checkbox"/>	<input checked="" type="checkbox"/>	<input checked="" type="checkbox"/>	<input checked="" type="checkbox"/>	<input checked="" type="checkbox"/>
28	27	26	25	24	23	22	21	20	19	18	17	16	15
<input type="checkbox"/>	<input type="checkbox"/>	<input checked="" type="checkbox"/>	<input checked="" type="checkbox"/>	<input checked="" type="checkbox"/>	<input checked="" type="checkbox"/>	<input checked="" type="checkbox"/>	<input checked="" type="checkbox"/>	<input checked="" type="checkbox"/>	<input checked="" type="checkbox"/>	<input type="checkbox"/>	<input type="checkbox"/>	<input type="checkbox"/>	<input checked="" type="checkbox"/>
14	13	12	11	10	9	8	7	6	5	4	3	2	1
<input type="checkbox"/>	<input type="checkbox"/>	<input checked="" type="checkbox"/>	<input checked="" type="checkbox"/>	<input checked="" type="checkbox"/>	<input checked="" type="checkbox"/>	<input checked="" type="checkbox"/>	<input checked="" type="checkbox"/>	<input checked="" type="checkbox"/>	<input checked="" type="checkbox"/>	<input checked="" type="checkbox"/>	<input type="checkbox"/>	<input type="checkbox"/>	<input checked="" type="checkbox"/>

FOR ADDITIONAL INFORMATION SEE SD-34576-001

STATUS	GM PART #	HRNS CONN ASSY			TPA GROMMET CAP																																																																												
		MATERIAL/PART	WIRE DRESS OPTION	KEY OPTION Fp	COLOR OPTION Fp	NUMBERS INDICATE CAVITIES OPEN FOR CIRCUITS																																																																											
		NUMBER				<table style="width: 100%; border-collapse: collapse; text-align: center;"> <tr> <td style="width: 10px;">48</td><td style="width: 10px;">47</td><td style="width: 10px;">46</td><td style="width: 10px;">45</td><td style="width: 10px;">44</td><td style="width: 10px;">43</td><td style="width: 10px;">42</td><td style="width: 10px;">41</td><td style="width: 10px;">40</td><td style="width: 10px;">39</td><td style="width: 10px;">38</td><td style="width: 10px;">37</td><td style="width: 10px;">36</td><td style="width: 10px;">35</td><td style="width: 10px;">34</td><td style="width: 10px;">33</td><td style="width: 10px;">32</td><td style="width: 10px;">31</td><td style="width: 10px;">30</td><td style="width: 10px;">29</td> </tr> <tr> <td colspan="11">49</td><td style="width: 10px;">20</td><td style="width: 10px;">19</td><td style="width: 10px;">18</td><td style="width: 10px;">17</td><td style="width: 10px;">16</td><td style="width: 10px;">15</td><td style="width: 10px;">14</td><td style="width: 10px;">13</td><td style="width: 10px;">12</td><td style="width: 10px;">11</td> </tr> <tr> <td colspan="11">49</td><td style="width: 10px;">10</td><td style="width: 10px;">9</td><td style="width: 10px;">8</td><td style="width: 10px;">7</td><td style="width: 10px;">6</td><td style="width: 10px;">5</td><td style="width: 10px;">4</td><td style="width: 10px;">3</td><td style="width: 10px;">2</td><td style="width: 10px;">1</td> </tr> </table>																			48	47	46	45	44	43	42	41	40	39	38	37	36	35	34	33	32	31	30	29	49											20	19	18	17	16	15	14	13	12	11	49											10	9	8	7	6
48	47	46	45	44	43	42	41	40	39	38	37	36	35	34	33	32	31	30	29																																																														
49											20	19	18	17	16	15	14	13	12	11																																																													
49											10	9	8	7	6	5	4	3	2	1																																																													
SALEABLE	12672838	34576-0103	0	A	BLACK																																																																												
CONCEPT ONLY	12672840	34576-0203	0	B	ST GRAY	48	47	46	45	44	43	42	41	40	39	38	37	36	35																																																														
SALEABLE	12672842	34576-0303	0	C	BLUE	34	33	32	31	30	29	28	27	26	25	24	23	22	21																																																														
CONCEPT ONLY	TBD	34576-0403	0	D	BROWN																																																																												
CONCEPT ONLY	TBD	34576-0503	0	E	GREEN																																																																												
CONCEPT ONLY	TBD	34576-0603	0	F	NATURAL																																																																												
SALEABLE	12672848	34576-0703	0	G	BLUE																																																																												
SALEABLE	12672846	34576-0803	0	H	ST GRAY	56	55	54	53	52	51	50	49	48	47	46	45	44	43																																																														
TOOL DES. REL.	12672844	34576-0903	0	J	BLACK	42	41	40	39	38	37	36	35	34	33	32	31	30	29																																																														
TOOL DES. REL.	TBD	34576-1003	0	K	BROWN	28	27	26	25	24	23	22	21	20	19	18	17	16	15																																																														
TOOL DES. REL.	TBD	34576-1103	0	L	GREEN	14	13	12	11	10	9	8	7	6	5	4	3	2	1																																																														
TOOL DES. REL.	TBD	34576-1203	0	M	NATURAL																																																																												
SALEABLE	12672839	34576-1303	9	A	BLACK																																																																												
CONCEPT ONLY	12672841	34576-1403	9	B	ST GRAY	48	47	46	45	44	43	42	41	40	39	38	37	36	35																																																														
SALEABLE	12672843	34576-1503	9	C	BLUE	34	33	32	31	30	29	28	27	26	25	24	23	22	21																																																														
CONCEPT ONLY	TBD	34576-1603	9	D	BROWN																																																																												
CONCEPT ONLY	TBD	34576-1703	9	E	GREEN																																																																												
CONCEPT ONLY	TBD	34576-1803	9	F	NATURAL																																																																												
SALEABLE	12672849	34576-1903	9	G	BLUE																																																																												



MX123 18/28/42/49/56-WAY RECEPTACLE ASSY SEALED PIN OUT SHEET

STATUS	GM PART #	HRNS CONN ASSY			TPA GROMMET CAP																
		MATERIAL/PART	WIRE DRESS OPTION	KEY OPTION	COLOR OPTION	NUMBERS INDICATE CAVITIES OPEN FOR CIRCUITS															
		NUMBER		OPTION	OPTION																
TOOL DES. REL.	12672847	34576-2003	9	H	ST GRY	56	55	54	53	52	51	50	49	48	47	46	45	44	43		
TOOL DES. REL.	12672845	34576-2103	9	J	BLACK	42	41	40	39	38	37	36	35	34	33	32	31	30	29		
TOOL DES. REL.	TBD	34576-2203	9	K	BROWN	28	27	26	25	24	23	22	21	20	19	18	17	16	15		
TOOL DES. REL.	TBD	34576-2303	9	L	GREEN	14	13	12	11	10	9	8	7	6	5	4	3	2	1		
TOOL DES. REL.	TBD	34576-2403	9	M	NATURAL																
SALEABLE	12672834	34851-0007	0	G	BLUE																
SALEABLE	12672836	34851-0008	0	H	ST GRY	18				17	16	15	14	1							
										13	12	11	10								
										9	8	7	6								
										5	4	3	2								
SALEABLE	12672835	34851-0019	9	G	BLUE																
SALEABLE	12672837	34851-0020	9	H	ST GRY	18				17	16	15	14	1							
										13	12	11	10								
										9	8	7	6								
										5	4	3	2								
CONCEPT ONLY		160095-0001	0	A	BLACK																
CONCEPT ONLY		160095-0002	0	B	ST GRY	27				26	25	24	23	22	21	1					
CONCEPT ONLY		160095-0003	0	C	BLUE	28				20	19	18	17	16	15	2					
										14	13	12	11	10	9						
										8	7	6	5	4	3						
CONCEPT ONLY		160095-0013	9	A	BLACK																
CONCEPT ONLY		160095-0014	9	B	ST GRY	1				21	22	23	24	25	26	27					
CONCEPT ONLY		160095-0015	9	C	BLUE	2				15	16	17	18	19	20	28					
										9	10	11	12	13	14						
										3	4	5	6	7	8						
CONCEPT ONLY		160051-0001	0	A	BLACK																
CONCEPT ONLY		160051-0003	0	C		1	2	3	4	5	6	7	8	9	10	42					
						11	12	13	14	15	16	17	18	19	20						
						41				21	22	23	24	25	26	27	28	29	30		
										31	32	33	34	35	36	37	38	39	40		
CONCEPT ONLY		160051-0013	9	A	BLACK																



MX123 18/28/42/49/56-WAY RECEPTACLE ASSY SEALED PIN OUT SHEET

STATUS	GM PART #	HRNS CONN ASSY			TPA GROMMET CAP																
		MATERIAL/PART	WIRE DRESS OPTION	KEY OPTION	COLOR OPTION	NUMBERS INDICATE CAVITIES OPEN FOR CIRCUITS															
		NUMBER		OPTION ▽ Fp	OPTION ▽ Fp	▽ Fp															
CONCEPT ONLY		160051-0015	9	C	BLUE	40	39	38	37	36	35	34	33	32	31	41					
						30	29	28	27	26	25	24	23	22	21						
						42				20	19	18	17	16	15	14	13	12	11		
						10	9	8	7	6	5	4	3	2	1						
SALEABLE	NOT APPLICABLE	34576-2503	0	G	BLUE	56	55	54	53				49	48	47			44			
								40			37	36	35	34	33						
													20	19	18						
								13	12			9	7	6				2			
SALEABLE	NOT APPLICABLE	34576-2603	0	G	BLUE	56	55	54	53				49	48	47			44			
								40			37	36	35	34	33						
													20	19	18						
								13	12			9	7	6							
SALEABLE	NOT APPLICABLE	34576-2703	0	G	BLUE																
SALEABLE	NOT APPLICABLE	34576-2803	0	G	BLUE		55	54	53		51		49	48	47			44			
								40			37	36	35	34	33						
								26						20	19	18					
								13	12			9	7								
SALEABLE	NOT APPLICABLE	34576-2903	0	G	BLUE	56	55		53				49	48	47	46	45	44			
								40	39		37	36	35	34	33			30			
									25					20	19	18					
								13	12			9	7								
SALEABLE	NOT APPLICABLE	34576-3003	0	G	BLUE	56	55	54	53				49	48	47			44			
								40			37	36	35	34	33				29		
														20	19	18		16	15		
								13	12			9	7	6				2			
SALEABLE	NOT APPLICABLE	34576-3103	0	G	BLUE	56	55	54	53				49	48	47	46	45	44			
								40	39		37	36	35	34	33						
														20	19	18					
								13	12			9	7								
SALEABLE	NOT APPLICABLE	34576-3203	0	G	BLUE		55	54	53				49	48	47	46		44			
								40			37	36	35	34	33	32	31				
								26						20	19	18					
								13	12			9	7								



MX123 18/28/42/49/56-WAY RECEPTACLE ASSY SEALED PIN OUT SHEET

STATUS	GM PART #	HRNS CONN ASSY			TPA GROMMET CAP															
		MATERIAL/PART	WIRE DRESS OPTION	KEY OPTION	COLOR OPTION	NUMBERS INDICATE CAVITIES OPEN FOR CIRCUITS														
		NUMBER		OPTION ▽ Fp		▽ Fp	▽ Fp													
SALEABLE	NOT APPLICABLE	34576-3303	0	G	BLUE	56	55	54					49	48	47			44		
								40			37	36	35	34	33					
														20	19	18				
SALEABLE	NOT APPLICABLE	34576-3403	0	G	BLUE		55	54	53				49	48	47			44		
								40	39		37	36	35	34	33					
								26						20	19	18				
SALEABLE	NOT APPLICABLE	34576-3503	0	G	BLUE	56	55		53				49	48	47			44		
								40			37	36	35	34	33					
														20	19	18				
SALEABLE	NOT APPLICABLE	34576-3603	0	G	BLUE		55	54	53				49	48	47			44		
								40			37	36	35	34	33					
								26						20	19	18				
SALEABLE	NOT APPLICABLE	34576-3703	0	G	BLUE	56	55	54	53		51		49	48	47			44		
								40			37	36	35	34	33				29	
														20	19	18			16	15
SALEABLE	NOT APPLICABLE	34576-3803	0	G	BLUE		55	54	53				49		47	46		44		
								40	39		37	36	35		33	32	31		29	
								25						20	19	18				15
SALEABLE	NOT APPLICABLE	34576-3903	0	G	BLUE	56		54	53				49		47			44		
								40	39		37	36	35		33				29	
								25						20	19	18				15
SALEABLE	NOT APPLICABLE	34576-4003	0	G	BLUE	56	55	54	53				49	48	47			45	44	
								40	39		37	36	35	34	33				29	
								25						20	19	18			16	15
SALEABLE	NOT APPLICABLE	34576-4103	0	G	BLUE		13	12			9		7	6				1		
						56	55	54	53				49	48	47	46		44		
								40	39	38	37	36	35	34	33	32	31		29	
		25						20	19	18			16							



MX123 18/28/42/49/56-WAY RECEPTACLE ASSY SEALED PIN OUT SHEET

STATUS	GM PART #	HRNS CONN ASSY			TPA GROMMET CAP																		
		MATERIAL/PART	WIRE DRESS OPTION	KEY OPTION ▽ Fp	COLOR OPTION ▽ Fp	NUMBERS INDICATE CAVITIES OPEN FOR CIRCUITS ▽ Fp																	
		NUMBER				56	55	54	53				49	48	47		45	44					
SALEABLE	NOT APPLICABLE	34576-4203	0	G	BLUE			40	39		37	36	35	34	33		20	19	18				
						13	12				9		7										
SALEABLE	NOT APPLICABLE	34576-4303	0	G	BLUE	56	55	54	53		51		49	48	47		45	44					
							41	40		38	37	36	35	34	33							30	
								26	25	24		22	21	20	19		17						
							13	12			9		7			4	3						1
SALEABLE	NOT APPLICABLE	34576-4403	0	G	BLUE	56	55	54	53				49	48	47	46		44					
								40	39		37	36	35	34	33	32	31					29	
									25					20	19	18						16	
								12			9		7										
SALEABLE	NOT APPLICABLE	34576-4503	0	G	BLUE	56	55		53				49	48	47	46		44					
								40	39		37	36	35	34	33	32	31					30	
									25	24		22	21	20	19	18						16	
							13	12			9		7			4						2	1
SALEABLE	NOT APPLICABLE	34576-4603	0	G	BLUE	56	55	54	53				49	48	47	46		44					
								40	39		37	36	35	34	33	32	31					29	
									25					20	19	18						16	
							13	12			9		7										
SALEABLE	NOT APPLICABLE	34576-4703	0	G	BLUE	56	55		53		51		49	48	47							44	
								40	39		37	36	35	34	33							30	
									25			22	21	20	19	18						16	15
							13	12			9		7			4						2	1
SALEABLE	NOT APPLICABLE	34576-4803	0	G	BLUE		55		53		51		49	48	47							44	
								40	39		37	36	35	34	33							29	
								26						20	19	18						16	15
							13	12			9		7			4						2	
TOOL DES. REL.	NOT APPLICABLE	34576-4903	9	G	BLUE		55	54	53				49	48	47	46		44					
								40			37	36	35	34	33	32	31						
								26						20	19	18							
							13	12			9		7										
SALEABLE	NOT APPLICABLE	34576-5003	0	G	BLUE		55	54	53				49	48	47		45	44					
								40			37	36	35	34	33								
								26						20	19	18							
							13	12			9		7										



MX123 18/28/42/49/56-WAY RECEPTACLE ASSY SEALED PIN OUT SHEET

STATUS	GM PART #	HRNS CONN ASSY			TPA GROMMET CAP															
		MATERIAL/PART	WIRE DRESS OPTION	KEY OPTION ▽ Fp	COLOR OPTION ▽ Fp	NUMBERS INDICATE CAVITIES OPEN FOR CIRCUITS ▽ Fp														
		NUMBER																		
SALEABLE	NOT APPLICABLE	34576-5103	0	G	BLUE		55		53		51		49	48	47			44		
								40			37	36	35	34	33				29	
								26		24				20	19	18			16	15
							13	12			9		7				4			2
SALEABLE	NOT APPLICABLE	34576-5203	0	G	BLUE	56	55	54	53				49	48	47			44		
								40	39		37	36	35	34	33				29	
														20	19	18				15
							13	12			9		7							
TOOL DES. REL.	NOT APPLICABLE	34576-5303	9	G	BLUE															
SALEABLE	NOT APPLICABLE	34576-5403	0	G	BLUE		55		53		51		49	48	47			44		
								40	39		37	36	35	34	33			30		
								26	25		22	21	20	19	18			16		
							13	12			9		7			4		2	1	
SALEABLE	NOT APPLICABLE	34576-5503	0	G	BLUE	56	55		53		51		49	48	47			44		
								40	39		37	36	35	34	33			30		
									25			22	21	20	19	18			16	
							13	12			9		7			4		2	1	
SALEABLE	NOT APPLICABLE	34576-5603	0	G	BLUE	56	55		53				49	48	47	46		44		
								40	39		37	36	35	34	33	32	31	30		
									25			22	21	20	19	18			16	
							13	12			9		7			4		2	1	
SALEABLE	NOT APPLICABLE	34576-5703	0	G	BLUE		55		53				49	48	47	46		44		
								40	39		37	36	35	34	33	32	31	30		
								26	25		22	21	20	19	18			16		
							13	12			9		7			4		2	1	
SALEABLE	NOT APPLICABLE	34576-5803	0	G	BLUE		55		53				49	48	47	46	45	44		
								40	39		37	36	35	34	33					
								26	25					20	19	18				
							13	12			9		7							
SALEABLE	NOT APPLICABLE	34576-5903	0	G	BLUE	56			53	52					47		45		43	
							41	40	39	38				34	33		31	30	29	
						28	27	26	25	24				20	19	18		16		
							13	12	11	10								3	2	



MX123 18/28/42/49/56-WAY RECEPTACLE ASSY SEALED PIN OUT SHEET

STATUS	GM PART #	HRNS CONN ASSY			TPA GROMMET CAP															
		MATERIAL/PART	WIRE DRESS OPTION	KEY OPTION ▽ Fp	COLOR OPTION ▽ Fp	NUMBERS INDICATE CAVITIES OPEN FOR CIRCUITS ▽ Fp														
		NUMBER				56			53	52		50			47		45		43	
SALEABLE	NOT APPLICABLE	34576-6003	0	G	BLUE			40	39	38				34	33		31	30	29	
						28	27	26	25	24			20	19	18		16			
						14	13	12	11	10					5	4	3	2		
SALEABLE	NOT APPLICABLE	34576-6103	0	G	BLUE	56	55	54	53		51		49	48	47				44	
								40	39		37	36	35	34	33				29	
														20	19	18			16	15
							13	12			9		7				4		2	
SALEABLE	NOT APPLICABLE	34576-6203	0	G	BLUE		55	54	53			49	48	47	46	45	44			
								40			37	36	35	34	33					
								26						20	19	18				
							13	12			9		7							
SALEABLE	NOT APPLICABLE	34576-6303	0	G	BLUE		55	54	53		51		49	48	47			44		
								40	39		37	36	35	34	33			29		
								26						20	19	18		16	15	
							13	12			9		7				4		2	
SALEABLE	NOT APPLICABLE	34576-6403	0	G	BLUE		55	54				49	48	47				44		
							41	40			37	36	35	34	33					
														20	19	18				
							13	12			9	8	7					3		
SALEABLE	NOT APPLICABLE	34576-6503	0	G	BLUE			54					47	46	45			43		
							41	40	39	38	37				33	32	31	30	29	
						28	27	26	25	24	23			20	19	18		16		
							13	12	11	10	9							3	2	
SALEABLE	NOT APPLICABLE	34576-6603	0	G	BLUE			54					47	46	45			43		
							41	40	39	38	37			34	33	32	31	30	29	
						28	27	26	25	24	23			20	19	18		16		
							13	12	11	10	9							3	2	
SALEABLE	NOT APPLICABLE	34576-6703	0	G	BLUE		55			52	51			48		46	45		43	
							41	40	39	38				33	32	31	30	29		
						28		26	25	24				20	19	18		16	15	
							13	12	11	10								3	2	1
SALEABLE	NOT APPLICABLE	34576-6803	0	G	BLUE					52			48		46	45			43	
							41	40	39	38				33	32	31	30	29		
						28		26	25	24				20	19	18		16	15	
							13	12	11	10								3	2	1



MX123 18/28/42/49/56-WAY RECEPTACLE ASSY SEALED PIN OUT SHEET

STATUS	GM PART #	HRNS CONN ASSY			TPA GROMMET CAP																																																								
		MATERIAL/PART	WIRE DRESS OPTION	KEY OPTION ▽ Fp	COLOR OPTION ▽ Fp	NUMBERS INDICATE CAVITIES OPEN FOR CIRCUITS ▽ Fp																																																							
		NUMBER				56	55	54	53	52	51	50	49	48	47	46	45	44	43	42	41	40	39	38	37	36	35	34	33	32	31	30	29	28	27	26	25	24	23	22	21	20	19	18	17	16	15	14	13	12	11	10	9	8	7	6	5	4	3	2	1
SALEABLE	NOT APPLICABLE	34576-6813	0	G	BLUE	56	55	54	53	52	51	50	49	48	47	46	45	44	43	42	41	40	39	38	37	36	35	34	33	32	31	30	29	28	27	26	25	24	23	22	21	20	19	18	17	16	15	14	13	12	11	10	9	8	7	6	5	4	3	2	1
SALEABLE	NOT APPLICABLE	34576-6823	0	G	BLUE	56	55	54	53	52	51	50	49	48	47	46	45	44	43	42	41	40	39	38	37	36	35	34	33	32	31	30	29	28	27	26	25	24	23	22	21	20	19	18	17	16	15	14	13	12	11	10	9	8	7	6	5	4	3	2	1
SALEABLE	NOT APPLICABLE	34576-6833	0	G	BLUE	56	55	54	53	52	51	50	49	48	47	46	45	44	43	42	41	40	39	38	37	36	35	34	33	32	31	30	29	28	27	26	25	24	23	22	21	20	19	18	17	16	15	14	13	12	11	10	9	8	7	6	5	4	3	2	1
SALEABLE	NOT APPLICABLE	34576-6843	0	G	BLUE	56	55	54	53	52	51	50	49	48	47	46	45	44	43	42	41	40	39	38	37	36	35	34	33	32	31	30	29	28	27	26	25	24	23	22	21	20	19	18	17	16	15	14	13	12	11	10	9	8	7	6	5	4	3	2	1
SALEABLE	NOT APPLICABLE	34576-6853	0	G	BLUE	56	55	54	53	52	51	50	49	48	47	46	45	44	43	42	41	40	39	38	37	36	35	34	33	32	31	30	29	28	27	26	25	24	23	22	21	20	19	18	17	16	15	14	13	12	11	10	9	8	7	6	5	4	3	2	1
SALEABLE	NOT APPLICABLE	34576-6863	0	G	BLUE	56	55	54	53	52	51	50	49	48	47	46	45	44	43	42	41	40	39	38	37	36	35	34	33	32	31	30	29	28	27	26	25	24	23	22	21	20	19	18	17	16	15	14	13	12	11	10	9	8	7	6	5	4	3	2	1
SALEABLE	NOT APPLICABLE	34576-6873	0	G	BLUE	56	55	54	53	52	51	50	49	48	47	46	45	44	43	42	41	40	39	38	37	36	35	34	33	32	31	30	29	28	27	26	25	24	23	22	21	20	19	18	17	16	15	14	13	12	11	10	9	8	7	6	5	4	3	2	1
SALEABLE	NOT APPLICABLE	34576-6883	0	G	BLUE	56	55	54	53	52	51	50	49	48	47	46	45	44	43	42	41	40	39	38	37	36	35	34	33	32	31	30	29	28	27	26	25	24	23	22	21	20	19	18	17	16	15	14	13	12	11	10	9	8	7	6	5	4	3	2	1
SALEABLE	NOT APPLICABLE	34576-6893	0	G	BLUE	56	55	54	53	52	51	50	49	48	47	46	45	44	43	42	41	40	39	38	37	36	35	34	33	32	31	30	29	28	27	26	25	24	23	22	21	20	19	18	17	16	15	14	13	12	11	10	9	8	7	6	5	4	3	2	1



MX123 18/28/42/49/56-WAY RECEPTACLE ASSY SEALED PIN OUT SHEET

STATUS	GM PART #	HRNS CONN ASSY			TPA GROMMET CAP																	
		MATERIAL/PART	WIRE DRESS OPTION	KEY OPTION	COLOR OPTION	NUMBERS INDICATE CAVITIES OPEN FOR CIRCUITS																
		NUMBER		OPTION																		
SALEABLE	NOT APPLICABLE	34576-6913	9	G	BLUE			54	53							47	46	45		43		
							41	40		38						33	32	31	30	29		
						28	27	26	25	24					20	19	18		16			
							13	12	11	10			8					3	2			
SALEABLE	NOT APPLICABLE	34576-6923	9	G	BLUE			54	53							47	46	45		43		
							41	40	39	38						33	32	31	30	29		
						28	27	26	25	24	23			20	19	18		16				
							13	12	11	10	9	8						3	2			
TOOL DES. REL.	NOT APPLICABLE	34851-0025	0	G	BLUE	18												1				
TOOL DES. REL.	NOT APPLICABLE	34851-0026	0	H	ST GRY	18												1				
SALEABLE	NOT APPLICABLE	34576-6933	0	G	BLUE		55	54	53				49	48	47	46	45	44				
								40			37	36	35	34	33							
								26						20	19	18						
							13	12			9		7									
SALEABLE	NOT APPLICABLE	34576-6943	0	G	BLUE			54	53							47	46	45		43		
							41	40		38					33	32	31	30	29			
						28		26	25	24				20	19	18		16				
							13	12	11	10			8					3	2			
SALEABLE	NOT APPLICABLE	34576-6953	0	G	BLUE			54	53							47	46	45		43		
							41	40	39	38					33	32	31	30	29			
						28	27	26	25	24	23			20	19	18		16				
							13	12	11	10	9	8						3	2			
SALEABLE	NOT APPLICABLE	34576-6963	0	G	BLUE		56		54	53	52					47	46	45		43		
								41	40	39	38				34	33	32	31	30	29		
						28	27	26	25	24	23			20	19	18		16				
								13	12	11	10	9	8					3	2			
SALEABLE	NOT APPLICABLE	34576-6973	0	G	BLUE		56				52	51	50							43		
							42	41		39	38						32	31	30	29		
						28	27		25	24	23	22	21					17	16	15		
							14			11	10		8		6	5	4	3	2	1		



MX123 18/28/42/49/56-WAY RECEPTACLE ASSY SEALED PIN OUT SHEET

STATUS	GM PART #	HRNS CONN ASSY			TPA GROMMET CAP																
		MATERIAL/PART	WIRE DRESS OPTION	KEY OPTION ▽ Fp	COLOR OPTION ▽ Fp	NUMBERS INDICATE CAVITIES OPEN FOR CIRCUITS ▽ Fp															
		NUMBER																			
SALEABLE	NOT APPLICABLE	34576-6983	0	G	BLUE			54	53								46		44		
								40	39	38	37	36					32	31	30		
									25	24	23	22	21	20	19						
									11	10	9	8	7	6	5	4					2
SALEABLE	NOT APPLICABLE	34576-6993	0	G	BLUE	56	55	54	53	52	51					47	46	45		43	
							41	40		38					33	32	31	30	29		
						28	27	26	25	24				20	19	18			16		
							13	12	11	10		8						3	2		
SALEABLE	NOT APPLICABLE	34576-7003	0	G	BLUE	56	55	54		52	51				47	46	45		43		
							41	40		38					33	32	31	30	29		
						28	27	26	25	24				20	19	18			16		
							13	12	11	10		8						3	2		
SALEABLE	NOT APPLICABLE	34576-7013	0	G	BLUE	56	55	54	53	52	51				47	46	45		43		
							41	40		38				34	33	32	31	30	29		
						28	27	26	25	24				20	19	18			16		
							13	12	11	10		8						3	2		
SALEABLE	NOT APPLICABLE	34576-7023	0	G	BLUE	56	55	54		52	51				47	46	45		43		
							41	40		38				34	33	32	31	30	29		
						28	27	26	25	24				20	19	18			16		
							13	12	11	10		8						3	2		
SALEABLE	NOT APPLICABLE	34576-7033	0	G	BLUE	56		54	53	52					47	46	45		43		
							41	40		38					33	32	31	30	29		
						28	27	26	25	24				20	19	18			16		
							13	12	11	10		8						3	2		
SALEABLE	NOT APPLICABLE	34576-7043	0	G	BLUE	56		54		52					47	46	45		43		
							41	40		38					33	32	31	30	29		
						28	27	26	25	24				20	19	18			16		
							13	12	11	10		8						3	2		
SALEABLE	NOT APPLICABLE	34576-7053	0	G	BLUE	56		54	53	52					47	46	45		43		
							41	40		38				34	33	32	31	30	29		
						28	27	26	25	24				20	19	18			16		
							13	12	11	10		8						3	2		
SALEABLE	NOT APPLICABLE	34576-7063	0	G	BLUE	56		54		52					47	46	45		43		
							41	40		38				34	33	32	31	30	29		
						28	27	26	25	24				20	19	18			16		
							13	12	11	10		8						3	2		



MX123 18/28/42/49/56-WAY RECEPTACLE ASSY SEALED PIN OUT SHEET

STATUS	GM PART #	HRNS CONN ASSY			TPA GROMMET CAP																
		MATERIAL/PART	WIRE DRESS OPTION	KEY OPTION ▽ Fp	COLOR OPTION ▽ Fp	NUMBERS INDICATE CAVITIES OPEN FOR CIRCUITS ▽ Fp															
		NUMBER																			
SALEABLE	NOT APPLICABLE	34576-7073	0	G	BLUE			54	53	52						47	46	45		43	
							41	40		38					33	32	31	30	29		
						28	27	26	25	24				20	19	18		16			
							13	12	11	10		8						3	2		
SALEABLE	NOT APPLICABLE	34576-7083	0	G	BLUE			54	53	52						47	46	45		43	
							41	40		38				34	33	32	31	30	29		
						28	27	26	25	24				20	19	18		16			
							13	12	11	10		8						3	2		
SALEABLE	NOT APPLICABLE	34576-7093	0	G	BLUE			54	53							47	46	45		43	
							41	40		38					33	32	31	30	29		
						28	27	26	25	24				20	19	18		16			
							13	12	11	10		8						3	2		
SALEABLE	NOT APPLICABLE	34576-7103	0	G	BLUE	56	55			52	51	50	49	48	47		45		43		
						42	41						35	34	33			29			
						28	27	26								18	17	16	15		
						14	13	12									3		1		
SALEABLE	NOT APPLICABLE	34576-7113	0	G	BLUE			54								47	46	45		43	
							41	40		38						33	32	31	30	29	
						28	27	26	25	24				20	19	18		16			
							13	12	11	10		8						3	2		
SALEABLE	NOT APPLICABLE	34576-7123	0	G	BLUE	56	55			52	51	50	49	48	47		45		43		
						42	41						35	34	33			29			
						28	27	26								18		16	15		
						14	13	12									3		1		
SALEABLE	NOT APPLICABLE	34576-7133	9	G	BLUE	56		54	53	52					47	46	45		43		
							41	40	39	38				34	33	32	31	30	29		
						28	27	26	25	24	23			20	19	18		16			
							13	12	11	10	9	8						3	2		
SALEABLE	NOT APPLICABLE	34576-7143	9	G	BLUE	56	55	54	53	52	51				47	46	45		43		
							41	40		38				34	33	32	31	30	29		
						28	27	26	25	24				20	19	18		16			
							13	12	11	10		8						3	2		
SALEABLE	NOT APPLICABLE	34576-7153	9	G	BLUE	56		54	53	52		49			47	46	45		43		
							41	40	39	38				34	33	32	31	30	29		
						28	27	26	25	24	23			20	19	18		16			
							13	12	11	10	9	8						3	2		



MX123 18/28/42/49/56-WAY RECEPTACLE ASSY SEALED PIN OUT SHEET

STATUS	GM PART #	HRNS CONN ASSY			TPA GROMMET CAP																	
		MATERIAL/PART	WIRE DRESS OPTION	KEY OPTION ▽ Fp	COLOR OPTION ▽ Fp	NUMBERS INDICATE CAVITIES OPEN FOR CIRCUITS ▽ Fp																
		NUMBER																				
SALEABLE	NOT APPLICABLE	34576-7163	0	G	BLUE				53				49		47	46	45	44				
								40			37	36	35		33							
								26						20	19	18						
								13	12				9		7							
SALEABLE	NOT APPLICABLE	34576-7173	9	G	BLUE		55			52	51			48		46	45		43			
							41	40		38					33	32	31	30	29			
						28		26		24				20	19	18			16	15		
							13	12		10								3	2	1		
SALEABLE	NOT APPLICABLE	34576-7183	0	G	BLUE	56	55		53				49	48	47	46		44				
								40	39		37	36	35	34	33	32	31	30				
									25	24			22	21	20	19	18		16			
							13	12				9		7			4		2	1		
SALEABLE	NOT APPLICABLE	34576-7193	9	G	BLUE	56		54	53	52					47	46	45		43			
							41	40		38				34	33	32	31	30	29			
						28	27	26		24				20	19	18			16			
							13	12		10								3	2			
SALEABLE	NOT APPLICABLE	34576-7203	0	G	BLUE	56	55	54	53	52	51				47	46	45		43			
							41	40		38				34	33	32	31	30	29			
						28	27	26	25	24				20	19	18			16			
							13	12	11	10			8					3	2			
SALEABLE	NOT APPLICABLE	34576-7213	0	G	BLUE	56	55			52	51	50	49	48	47	46	45		43			
						42	41						35	34	33		31		29			
						28	27	26					21		19	18			16	15		
						14	13	12									4	3		1		
SALEABLE	NOT APPLICABLE	34576-7223	0	G	BLUE			54	53						47	46	45		43			
							41	40	39	38				34	33		31	30	29			
						28	27	26	25	24			21	20	19	18			16			
							13	12	11	10				6				3	2			
SALEABLE	NOT APPLICABLE	34576-7233	0	G	BLUE										46	45						
															33							
													21			18	17					
																		3				
SALEABLE	NOT APPLICABLE	34576-7243	0	G	BLUE			54	53						47		45		43			
							41	40	39	38				34	33		31	30	29			
						28	27	26	25	24				20	19	18			16			
							13	12	11	10								3	2			



MX123 18/28/42/49/56-WAY RECEPTACLE ASSY SEALED PIN OUT SHEET

STATUS	GM PART #	HRNS CONN ASSY			TPA GROMMET CAP															
		MATERIAL/PART	WIRE DRESS OPTION	KEY OPTION ▽ Fp	COLOR OPTION ▽ Fp	NUMBERS INDICATE CAVITIES OPEN FOR CIRCUITS ▽ Fp														
		NUMBER																		
SALEABLE	NOT APPLICABLE	34851-0027	0	G	BLUE	18										1				
						9					7					6				
						5					3					2				
SALEABLE	NOT APPLICABLE	34851-0028	0	H	ST GRY	18										1				
						17	16				15	14				10				
						5	4				3	2				6				
SALEABLE	NOT APPLICABLE	34576-7253	0	G	BLUE	56		54	53	52					47	46	45		43	
						41	40	39	38					33	32	31	30	29		
						28	27	26	25	24	23			20	19	18		16		
						13	12	11	10	9	8						3	2		
SALEABLE	NOT APPLICABLE	34576-7263	0	G	BLUE	56	55	54	53	52	51	50					45		43	
						42	41	40	39				35	34	33					
						28	27								18			16		
						14	13										3	2		
SALEABLE	NOT APPLICABLE	34576-7273	0	G	BLUE	56	55	54	53	52	51	50					45		43	
						42	41	40	39				35	34	33					
						28	27								18			16		
						14	13										3	2		
SALEABLE	NOT APPLICABLE	34576-7283	0	G	BLUE			54	53						47	46	45		43	
						41	40			38				34	33	32	31	30	29	
						28	27	26	25	24				20	19	18		16		
						13	12	11	10		8			6			3	2		
SALEABLE	NOT APPLICABLE	34576-7293	9	G	BLUE			54	53				49	48	47	46	45		43	
						41	40			38					33	32	31	30	29	
						28	27	26	25	24				20	19	18		16	15	
						13	12	11	10		8			6			3	2	1	
SALEABLE	NOT APPLICABLE	34576-7303	0	G	BLUE	56	55			52	51	50					45		43	
						42	41						35	34	33					
						28	27								18			16		
						14	13										3			
SALEABLE	NOT APPLICABLE	34576-7313	0	G	BLUE	56	55	54	53	52	51	50					45		43	
						42	41	40	39				35	34	33					
						28	27				23					18	17	16		
						14	13				9					3	2			





MX123 18/28/42/49/56-WAY RECEPTACLE ASSY SEALED PIN OUT SHEET

STATUS	GM PART #	HRNS CONN ASSY			TPA GROMMET CAP															
		MATERIAL/PART	WIRE DRESS OPTION	KEY OPTION	COLOR OPTION	NUMBERS INDICATE CAVITIES OPEN FOR CIRCUITS														
		NUMBER		OPTION			<div style="text-align: center;"> </div>													
SALEABLE	NOT APPLICABLE	34576-7323	0	G	BLUE	56	55	54	53	52	51	50					45			
						42	41	40	39				35	34	33					
						28	27				23					18		16		
						14	13				9						3	2		
SALEABLE	NOT APPLICABLE	34576-7333	0	G	BLUE	56	55	54	53	52	51	50					45			
						42	41	40	39				35	34	33					
						28	27									18	17	16		
						14	13										3	2		
SALEABLE	NOT APPLICABLE	34576-7343	0	G	BLUE	56	55			52	51	50				46	45			
						42	41							33						
						28	27						21			18	17	16		
						14	13										3			
SALEABLE	NOT APPLICABLE	34576-7353	0	G	BLUE	56			53	52		50			47	46	45	43		
								40		38			34	33	32	31	30	29		
						28	27	26	25	24			20	19	18		16			
							13	12	11	10		8					3	2		
SALEABLE	NOT APPLICABLE	34851-0029	9	G	BLUE	18							14	1						
											11	10								
											8	7								
											4	3	2							
SALEABLE	NOT APPLICABLE	34576-7363	0	H	ST. GRAY						51	50		48	47	46	45			
													34	33	32	31		29		
													21	20						
											9	8	7	6		4	3	2	1	
SALEABLE	NOT APPLICABLE	34576-7373	9	G	BLUE					52			48	47				43		
								40			37	36		34				30		
										24				20					15	
						14							7							
SALEABLE	NOT APPLICABLE	34851-0030	0	H	ST. GRAY	18					17	16	15	14	1					
													10							
														6						
													4	3	2					
SALEABLE	NOT APPLICABLE	34576-9113	0	A	BLACK															
						49														



MX123 18/28/42/49/56-WAY RECEPTACLE ASSY SEALED PIN OUT SHEET

STATUS	GM PART #	HRNS CONN ASSY			TPA GROMMET CAP																																																																																																																																																																																																																																																																																																																																																																																																																																																																																																																																																																																																																																																																																																										
		MATERIAL/PART	WIRE DRESS OPTION	KEY OPTION 	COLOR OPTION 	NUMBERS INDICATE CAVITIES OPEN FOR CIRCUITS 																																																																																																																																																																																																																																																																																																																																																																																																																																																																																																																																																																																																																																																																																																									
		NUMBER																																																																																																																																																																																																																																																																																																																																																																																																																																																																																																																																																																																																																																																																																																													
SALEABLE	NOT APPLICABLE	34576-9123	0	C	BLUE	49																																																																																																																																																																																																																																																																																																																																																																																																																																																																																																																																																																																																																																																																																																									
SALEABLE	NOT APPLICABLE	34576-7383	9	G	BLUE	56	55	54	53				49	48	47		45	44										40	39		37	36	35	34	33			29										25					20	19	18			16	15										13	12			9	7	6				1	SALEABLE	NOT APPLICABLE	34576-7393	0	G	BLUE	56	55			52	51	50					46	45	44								42	41																											21		19	18				15							14	13					8						3			SALEABLE	NOT APPLICABLE	34576-7403	0	G	BLUE	56	55			52	51	50						45									42	41																				28	27					22					18	17	16								14	13					8					3				SALEABLE	NOT APPLICABLE	34576-7413	0	G	BLUE			54	53				49	48	47		46			44	43									40	39	38	37	36					32	31	30	29										26	25	24	23		21	20	19		17			15										12	11	10	9		7	6	5	4				2	1	SALEABLE	NOT APPLICABLE	34576-7423	0	G	BLUE			54	53				49	48	47	46				44	43									40	39	38	37	36	35	34	33	32	31	30	29											26	25	24	23		21	20	19		17			15										12	11	10	9		7	6	5	4				2	1	SALEABLE	NOT APPLICABLE	34576-7433	0	G	BLUE			54	53				49	48	47	46				44	43									40	39	38	37	36	35	34	33	32	31	30	29											26	25	24	23		21	20	19				15											12	11	10	9		7	6	5	4				2	1	SALEABLE	NOT APPLICABLE	34576-7443	0	G	BLUE			54	53				49	48	47					44	43									40	39	38	37	36					32	31	30	29										26	25	24	23		20				17			15										12	11	10	9		7	6	5	4				2	1	SALEABLE	NOT APPLICABLE	34576-7453	9	G	BLUE					52				48	47		45			43										40			37	36		34						30												24				20							15								14						7								
								40	39		37	36	35	34	33			29										25					20	19	18			16	15										13	12			9	7	6				1	SALEABLE	NOT APPLICABLE	34576-7393	0	G	BLUE	56	55			52	51	50					46	45	44								42	41																											21		19	18				15							14	13					8						3			SALEABLE	NOT APPLICABLE	34576-7403	0	G	BLUE	56	55			52	51	50						45									42	41																				28	27					22					18	17	16								14	13					8					3				SALEABLE	NOT APPLICABLE	34576-7413	0	G	BLUE			54	53				49	48	47		46			44	43									40	39	38	37	36					32	31	30	29										26	25	24	23		21	20	19		17			15										12	11	10	9		7	6	5	4				2	1	SALEABLE	NOT APPLICABLE	34576-7423	0	G	BLUE			54	53				49	48	47	46				44	43									40	39	38	37	36	35	34	33	32	31	30	29											26	25	24	23		21	20	19		17			15										12	11	10	9		7	6	5	4				2	1	SALEABLE	NOT APPLICABLE	34576-7433	0	G	BLUE			54	53				49	48	47	46				44	43									40	39	38	37	36	35	34	33	32	31	30	29											26	25	24	23		21	20	19				15											12	11	10	9		7	6	5	4				2	1	SALEABLE	NOT APPLICABLE	34576-7443	0	G	BLUE			54	53				49	48	47					44	43									40	39	38	37	36					32	31	30	29										26	25	24	23		20				17			15										12	11	10	9		7	6	5	4				2	1	SALEABLE	NOT APPLICABLE	34576-7453	9	G	BLUE					52				48	47		45			43										40			37	36		34						30												24				20							15								14						7																												
								25					20	19	18			16	15										13	12			9	7	6				1	SALEABLE	NOT APPLICABLE	34576-7393	0	G	BLUE	56	55			52	51	50					46	45	44								42	41																											21		19	18				15							14	13					8						3			SALEABLE	NOT APPLICABLE	34576-7403	0	G	BLUE	56	55			52	51	50						45									42	41																				28	27					22					18	17	16								14	13					8					3				SALEABLE	NOT APPLICABLE	34576-7413	0	G	BLUE			54	53				49	48	47		46			44	43									40	39	38	37	36					32	31	30	29										26	25	24	23		21	20	19		17			15										12	11	10	9		7	6	5	4				2	1	SALEABLE	NOT APPLICABLE	34576-7423	0	G	BLUE			54	53				49	48	47	46				44	43									40	39	38	37	36	35	34	33	32	31	30	29											26	25	24	23		21	20	19		17			15										12	11	10	9		7	6	5	4				2	1	SALEABLE	NOT APPLICABLE	34576-7433	0	G	BLUE			54	53				49	48	47	46				44	43									40	39	38	37	36	35	34	33	32	31	30	29											26	25	24	23		21	20	19				15											12	11	10	9		7	6	5	4				2	1	SALEABLE	NOT APPLICABLE	34576-7443	0	G	BLUE			54	53				49	48	47					44	43									40	39	38	37	36					32	31	30	29										26	25	24	23		20				17			15										12	11	10	9		7	6	5	4				2	1	SALEABLE	NOT APPLICABLE	34576-7453	9	G	BLUE					52				48	47		45			43										40			37	36		34						30												24				20							15								14						7																																																
									13	12			9	7	6				1	SALEABLE	NOT APPLICABLE	34576-7393	0	G	BLUE	56	55			52	51	50					46	45	44								42	41																											21		19	18				15							14	13					8						3			SALEABLE	NOT APPLICABLE	34576-7403	0	G	BLUE	56	55			52	51	50						45									42	41																				28	27					22					18	17	16								14	13					8					3				SALEABLE	NOT APPLICABLE	34576-7413	0	G	BLUE			54	53				49	48	47		46			44	43									40	39	38	37	36					32	31	30	29										26	25	24	23		21	20	19		17			15										12	11	10	9		7	6	5	4				2	1	SALEABLE	NOT APPLICABLE	34576-7423	0	G	BLUE			54	53				49	48	47	46				44	43									40	39	38	37	36	35	34	33	32	31	30	29											26	25	24	23		21	20	19		17			15										12	11	10	9		7	6	5	4				2	1	SALEABLE	NOT APPLICABLE	34576-7433	0	G	BLUE			54	53				49	48	47	46				44	43									40	39	38	37	36	35	34	33	32	31	30	29											26	25	24	23		21	20	19				15											12	11	10	9		7	6	5	4				2	1	SALEABLE	NOT APPLICABLE	34576-7443	0	G	BLUE			54	53				49	48	47					44	43									40	39	38	37	36					32	31	30	29										26	25	24	23		20				17			15										12	11	10	9		7	6	5	4				2	1	SALEABLE	NOT APPLICABLE	34576-7453	9	G	BLUE					52				48	47		45			43										40			37	36		34						30												24				20							15								14						7																																																																				
SALEABLE	NOT APPLICABLE	34576-7393	0	G	BLUE	56	55			52	51	50					46	45	44								42	41																											21		19	18				15							14	13					8						3			SALEABLE	NOT APPLICABLE	34576-7403	0	G	BLUE	56	55			52	51	50						45									42	41																				28	27					22					18	17	16								14	13					8					3				SALEABLE	NOT APPLICABLE	34576-7413	0	G	BLUE			54	53				49	48	47		46			44	43									40	39	38	37	36					32	31	30	29										26	25	24	23		21	20	19		17			15										12	11	10	9		7	6	5	4				2	1	SALEABLE	NOT APPLICABLE	34576-7423	0	G	BLUE			54	53				49	48	47	46				44	43									40	39	38	37	36	35	34	33	32	31	30	29											26	25	24	23		21	20	19		17			15										12	11	10	9		7	6	5	4				2	1	SALEABLE	NOT APPLICABLE	34576-7433	0	G	BLUE			54	53				49	48	47	46				44	43									40	39	38	37	36	35	34	33	32	31	30	29											26	25	24	23		21	20	19				15											12	11	10	9		7	6	5	4				2	1	SALEABLE	NOT APPLICABLE	34576-7443	0	G	BLUE			54	53				49	48	47					44	43									40	39	38	37	36					32	31	30	29										26	25	24	23		20				17			15										12	11	10	9		7	6	5	4				2	1	SALEABLE	NOT APPLICABLE	34576-7453	9	G	BLUE					52				48	47		45			43										40			37	36		34						30												24				20							15								14						7																																																																																								
						42	41																											21		19	18				15							14	13					8						3			SALEABLE	NOT APPLICABLE	34576-7403	0	G	BLUE	56	55			52	51	50						45									42	41																				28	27					22					18	17	16								14	13					8					3				SALEABLE	NOT APPLICABLE	34576-7413	0	G	BLUE			54	53				49	48	47		46			44	43									40	39	38	37	36					32	31	30	29										26	25	24	23		21	20	19		17			15										12	11	10	9		7	6	5	4				2	1	SALEABLE	NOT APPLICABLE	34576-7423	0	G	BLUE			54	53				49	48	47	46				44	43									40	39	38	37	36	35	34	33	32	31	30	29											26	25	24	23		21	20	19		17			15										12	11	10	9		7	6	5	4				2	1	SALEABLE	NOT APPLICABLE	34576-7433	0	G	BLUE			54	53				49	48	47	46				44	43									40	39	38	37	36	35	34	33	32	31	30	29											26	25	24	23		21	20	19				15											12	11	10	9		7	6	5	4				2	1	SALEABLE	NOT APPLICABLE	34576-7443	0	G	BLUE			54	53				49	48	47					44	43									40	39	38	37	36					32	31	30	29										26	25	24	23		20				17			15										12	11	10	9		7	6	5	4				2	1	SALEABLE	NOT APPLICABLE	34576-7453	9	G	BLUE					52				48	47		45			43										40			37	36		34						30												24				20							15								14						7																																																																																																													
													21		19	18				15							14	13					8						3			SALEABLE	NOT APPLICABLE	34576-7403	0	G	BLUE	56	55			52	51	50						45									42	41																				28	27					22					18	17	16								14	13					8					3				SALEABLE	NOT APPLICABLE	34576-7413	0	G	BLUE			54	53				49	48	47		46			44	43									40	39	38	37	36					32	31	30	29										26	25	24	23		21	20	19		17			15										12	11	10	9		7	6	5	4				2	1	SALEABLE	NOT APPLICABLE	34576-7423	0	G	BLUE			54	53				49	48	47	46				44	43									40	39	38	37	36	35	34	33	32	31	30	29											26	25	24	23		21	20	19		17			15										12	11	10	9		7	6	5	4				2	1	SALEABLE	NOT APPLICABLE	34576-7433	0	G	BLUE			54	53				49	48	47	46				44	43									40	39	38	37	36	35	34	33	32	31	30	29											26	25	24	23		21	20	19				15											12	11	10	9		7	6	5	4				2	1	SALEABLE	NOT APPLICABLE	34576-7443	0	G	BLUE			54	53				49	48	47					44	43									40	39	38	37	36					32	31	30	29										26	25	24	23		20				17			15										12	11	10	9		7	6	5	4				2	1	SALEABLE	NOT APPLICABLE	34576-7453	9	G	BLUE					52				48	47		45			43										40			37	36		34						30												24				20							15								14						7																																																																																																																																		
						14	13					8						3			SALEABLE	NOT APPLICABLE	34576-7403	0	G	BLUE	56	55			52	51	50						45									42	41																				28	27					22					18	17	16								14	13					8					3				SALEABLE	NOT APPLICABLE	34576-7413	0	G	BLUE			54	53				49	48	47		46			44	43									40	39	38	37	36					32	31	30	29										26	25	24	23		21	20	19		17			15										12	11	10	9		7	6	5	4				2	1	SALEABLE	NOT APPLICABLE	34576-7423	0	G	BLUE			54	53				49	48	47	46				44	43									40	39	38	37	36	35	34	33	32	31	30	29											26	25	24	23		21	20	19		17			15										12	11	10	9		7	6	5	4				2	1	SALEABLE	NOT APPLICABLE	34576-7433	0	G	BLUE			54	53				49	48	47	46				44	43									40	39	38	37	36	35	34	33	32	31	30	29											26	25	24	23		21	20	19				15											12	11	10	9		7	6	5	4				2	1	SALEABLE	NOT APPLICABLE	34576-7443	0	G	BLUE			54	53				49	48	47					44	43									40	39	38	37	36					32	31	30	29										26	25	24	23		20				17			15										12	11	10	9		7	6	5	4				2	1	SALEABLE	NOT APPLICABLE	34576-7453	9	G	BLUE					52				48	47		45			43										40			37	36		34						30												24				20							15								14						7																																																																																																																																																							
SALEABLE	NOT APPLICABLE	34576-7403	0	G	BLUE	56	55			52	51	50						45									42	41																				28	27					22					18	17	16								14	13					8					3				SALEABLE	NOT APPLICABLE	34576-7413	0	G	BLUE			54	53				49	48	47		46			44	43									40	39	38	37	36					32	31	30	29										26	25	24	23		21	20	19		17			15										12	11	10	9		7	6	5	4				2	1	SALEABLE	NOT APPLICABLE	34576-7423	0	G	BLUE			54	53				49	48	47	46				44	43									40	39	38	37	36	35	34	33	32	31	30	29											26	25	24	23		21	20	19		17			15										12	11	10	9		7	6	5	4				2	1	SALEABLE	NOT APPLICABLE	34576-7433	0	G	BLUE			54	53				49	48	47	46				44	43									40	39	38	37	36	35	34	33	32	31	30	29											26	25	24	23		21	20	19				15											12	11	10	9		7	6	5	4				2	1	SALEABLE	NOT APPLICABLE	34576-7443	0	G	BLUE			54	53				49	48	47					44	43									40	39	38	37	36					32	31	30	29										26	25	24	23		20				17			15										12	11	10	9		7	6	5	4				2	1	SALEABLE	NOT APPLICABLE	34576-7453	9	G	BLUE					52				48	47		45			43										40			37	36		34						30												24				20							15								14						7																																																																																																																																																																												
						42	41																				28	27					22					18	17	16								14	13					8					3				SALEABLE	NOT APPLICABLE	34576-7413	0	G	BLUE			54	53				49	48	47		46			44	43									40	39	38	37	36					32	31	30	29										26	25	24	23		21	20	19		17			15										12	11	10	9		7	6	5	4				2	1	SALEABLE	NOT APPLICABLE	34576-7423	0	G	BLUE			54	53				49	48	47	46				44	43									40	39	38	37	36	35	34	33	32	31	30	29											26	25	24	23		21	20	19		17			15										12	11	10	9		7	6	5	4				2	1	SALEABLE	NOT APPLICABLE	34576-7433	0	G	BLUE			54	53				49	48	47	46				44	43									40	39	38	37	36	35	34	33	32	31	30	29											26	25	24	23		21	20	19				15											12	11	10	9		7	6	5	4				2	1	SALEABLE	NOT APPLICABLE	34576-7443	0	G	BLUE			54	53				49	48	47					44	43									40	39	38	37	36					32	31	30	29										26	25	24	23		20				17			15										12	11	10	9		7	6	5	4				2	1	SALEABLE	NOT APPLICABLE	34576-7453	9	G	BLUE					52				48	47		45			43										40			37	36		34						30												24				20							15								14						7																																																																																																																																																																																																	
						28	27					22					18	17	16								14	13					8					3				SALEABLE	NOT APPLICABLE	34576-7413	0	G	BLUE			54	53				49	48	47		46			44	43									40	39	38	37	36					32	31	30	29										26	25	24	23		21	20	19		17			15										12	11	10	9		7	6	5	4				2	1	SALEABLE	NOT APPLICABLE	34576-7423	0	G	BLUE			54	53				49	48	47	46				44	43									40	39	38	37	36	35	34	33	32	31	30	29											26	25	24	23		21	20	19		17			15										12	11	10	9		7	6	5	4				2	1	SALEABLE	NOT APPLICABLE	34576-7433	0	G	BLUE			54	53				49	48	47	46				44	43									40	39	38	37	36	35	34	33	32	31	30	29											26	25	24	23		21	20	19				15											12	11	10	9		7	6	5	4				2	1	SALEABLE	NOT APPLICABLE	34576-7443	0	G	BLUE			54	53				49	48	47					44	43									40	39	38	37	36					32	31	30	29										26	25	24	23		20				17			15										12	11	10	9		7	6	5	4				2	1	SALEABLE	NOT APPLICABLE	34576-7453	9	G	BLUE					52				48	47		45			43										40			37	36		34						30												24				20							15								14						7																																																																																																																																																																																																																						
						14	13					8					3				SALEABLE	NOT APPLICABLE	34576-7413	0	G	BLUE			54	53				49	48	47		46			44	43									40	39	38	37	36					32	31	30	29										26	25	24	23		21	20	19		17			15										12	11	10	9		7	6	5	4				2	1	SALEABLE	NOT APPLICABLE	34576-7423	0	G	BLUE			54	53				49	48	47	46				44	43									40	39	38	37	36	35	34	33	32	31	30	29											26	25	24	23		21	20	19		17			15										12	11	10	9		7	6	5	4				2	1	SALEABLE	NOT APPLICABLE	34576-7433	0	G	BLUE			54	53				49	48	47	46				44	43									40	39	38	37	36	35	34	33	32	31	30	29											26	25	24	23		21	20	19				15											12	11	10	9		7	6	5	4				2	1	SALEABLE	NOT APPLICABLE	34576-7443	0	G	BLUE			54	53				49	48	47					44	43									40	39	38	37	36					32	31	30	29										26	25	24	23		20				17			15										12	11	10	9		7	6	5	4				2	1	SALEABLE	NOT APPLICABLE	34576-7453	9	G	BLUE					52				48	47		45			43										40			37	36		34						30												24				20							15								14						7																																																																																																																																																																																																																																											
SALEABLE	NOT APPLICABLE	34576-7413	0	G	BLUE			54	53				49	48	47		46			44	43									40	39	38	37	36					32	31	30	29										26	25	24	23		21	20	19		17			15										12	11	10	9		7	6	5	4				2	1	SALEABLE	NOT APPLICABLE	34576-7423	0	G	BLUE			54	53				49	48	47	46				44	43									40	39	38	37	36	35	34	33	32	31	30	29											26	25	24	23		21	20	19		17			15										12	11	10	9		7	6	5	4				2	1	SALEABLE	NOT APPLICABLE	34576-7433	0	G	BLUE			54	53				49	48	47	46				44	43									40	39	38	37	36	35	34	33	32	31	30	29											26	25	24	23		21	20	19				15											12	11	10	9		7	6	5	4				2	1	SALEABLE	NOT APPLICABLE	34576-7443	0	G	BLUE			54	53				49	48	47					44	43									40	39	38	37	36					32	31	30	29										26	25	24	23		20				17			15										12	11	10	9		7	6	5	4				2	1	SALEABLE	NOT APPLICABLE	34576-7453	9	G	BLUE					52				48	47		45			43										40			37	36		34						30												24				20							15								14						7																																																																																																																																																																																																																																																																
								40	39	38	37	36					32	31	30	29										26	25	24	23		21	20	19		17			15										12	11	10	9		7	6	5	4				2	1	SALEABLE	NOT APPLICABLE	34576-7423	0	G	BLUE			54	53				49	48	47	46				44	43									40	39	38	37	36	35	34	33	32	31	30	29											26	25	24	23		21	20	19		17			15										12	11	10	9		7	6	5	4				2	1	SALEABLE	NOT APPLICABLE	34576-7433	0	G	BLUE			54	53				49	48	47	46				44	43									40	39	38	37	36	35	34	33	32	31	30	29											26	25	24	23		21	20	19				15											12	11	10	9		7	6	5	4				2	1	SALEABLE	NOT APPLICABLE	34576-7443	0	G	BLUE			54	53				49	48	47					44	43									40	39	38	37	36					32	31	30	29										26	25	24	23		20				17			15										12	11	10	9		7	6	5	4				2	1	SALEABLE	NOT APPLICABLE	34576-7453	9	G	BLUE					52				48	47		45			43										40			37	36		34						30												24				20							15								14						7																																																																																																																																																																																																																																																																																						
								26	25	24	23		21	20	19		17			15										12	11	10	9		7	6	5	4				2	1	SALEABLE	NOT APPLICABLE	34576-7423	0	G	BLUE			54	53				49	48	47	46				44	43									40	39	38	37	36	35	34	33	32	31	30	29											26	25	24	23		21	20	19		17			15										12	11	10	9		7	6	5	4				2	1	SALEABLE	NOT APPLICABLE	34576-7433	0	G	BLUE			54	53				49	48	47	46				44	43									40	39	38	37	36	35	34	33	32	31	30	29											26	25	24	23		21	20	19				15											12	11	10	9		7	6	5	4				2	1	SALEABLE	NOT APPLICABLE	34576-7443	0	G	BLUE			54	53				49	48	47					44	43									40	39	38	37	36					32	31	30	29										26	25	24	23		20				17			15										12	11	10	9		7	6	5	4				2	1	SALEABLE	NOT APPLICABLE	34576-7453	9	G	BLUE					52				48	47		45			43										40			37	36		34						30												24				20							15								14						7																																																																																																																																																																																																																																																																																																												
								12	11	10	9		7	6	5	4				2	1	SALEABLE	NOT APPLICABLE	34576-7423	0	G	BLUE			54	53				49	48	47	46				44	43									40	39	38	37	36	35	34	33	32	31	30	29											26	25	24	23		21	20	19		17			15										12	11	10	9		7	6	5	4				2	1	SALEABLE	NOT APPLICABLE	34576-7433	0	G	BLUE			54	53				49	48	47	46				44	43									40	39	38	37	36	35	34	33	32	31	30	29											26	25	24	23		21	20	19				15											12	11	10	9		7	6	5	4				2	1	SALEABLE	NOT APPLICABLE	34576-7443	0	G	BLUE			54	53				49	48	47					44	43									40	39	38	37	36					32	31	30	29										26	25	24	23		20				17			15										12	11	10	9		7	6	5	4				2	1	SALEABLE	NOT APPLICABLE	34576-7453	9	G	BLUE					52				48	47		45			43										40			37	36		34						30												24				20							15								14						7																																																																																																																																																																																																																																																																																																																																		
SALEABLE	NOT APPLICABLE	34576-7423	0	G	BLUE			54	53				49	48	47	46				44	43									40	39	38	37	36	35	34	33	32	31	30	29											26	25	24	23		21	20	19		17			15										12	11	10	9		7	6	5	4				2	1	SALEABLE	NOT APPLICABLE	34576-7433	0	G	BLUE			54	53				49	48	47	46				44	43									40	39	38	37	36	35	34	33	32	31	30	29											26	25	24	23		21	20	19				15											12	11	10	9		7	6	5	4				2	1	SALEABLE	NOT APPLICABLE	34576-7443	0	G	BLUE			54	53				49	48	47					44	43									40	39	38	37	36					32	31	30	29										26	25	24	23		20				17			15										12	11	10	9		7	6	5	4				2	1	SALEABLE	NOT APPLICABLE	34576-7453	9	G	BLUE					52				48	47		45			43										40			37	36		34						30												24				20							15								14						7																																																																																																																																																																																																																																																																																																																																																								
								40	39	38	37	36	35	34	33	32	31	30	29											26	25	24	23		21	20	19		17			15										12	11	10	9		7	6	5	4				2	1	SALEABLE	NOT APPLICABLE	34576-7433	0	G	BLUE			54	53				49	48	47	46				44	43									40	39	38	37	36	35	34	33	32	31	30	29											26	25	24	23		21	20	19				15											12	11	10	9		7	6	5	4				2	1	SALEABLE	NOT APPLICABLE	34576-7443	0	G	BLUE			54	53				49	48	47					44	43									40	39	38	37	36					32	31	30	29										26	25	24	23		20				17			15										12	11	10	9		7	6	5	4				2	1	SALEABLE	NOT APPLICABLE	34576-7453	9	G	BLUE					52				48	47		45			43										40			37	36		34						30												24				20							15								14						7																																																																																																																																																																																																																																																																																																																																																																														
								26	25	24	23		21	20	19		17			15										12	11	10	9		7	6	5	4				2	1	SALEABLE	NOT APPLICABLE	34576-7433	0	G	BLUE			54	53				49	48	47	46				44	43									40	39	38	37	36	35	34	33	32	31	30	29											26	25	24	23		21	20	19				15											12	11	10	9		7	6	5	4				2	1	SALEABLE	NOT APPLICABLE	34576-7443	0	G	BLUE			54	53				49	48	47					44	43									40	39	38	37	36					32	31	30	29										26	25	24	23		20				17			15										12	11	10	9		7	6	5	4				2	1	SALEABLE	NOT APPLICABLE	34576-7453	9	G	BLUE					52				48	47		45			43										40			37	36		34						30												24				20							15								14						7																																																																																																																																																																																																																																																																																																																																																																																																				
								12	11	10	9		7	6	5	4				2	1	SALEABLE	NOT APPLICABLE	34576-7433	0	G	BLUE			54	53				49	48	47	46				44	43									40	39	38	37	36	35	34	33	32	31	30	29											26	25	24	23		21	20	19				15											12	11	10	9		7	6	5	4				2	1	SALEABLE	NOT APPLICABLE	34576-7443	0	G	BLUE			54	53				49	48	47					44	43									40	39	38	37	36					32	31	30	29										26	25	24	23		20				17			15										12	11	10	9		7	6	5	4				2	1	SALEABLE	NOT APPLICABLE	34576-7453	9	G	BLUE					52				48	47		45			43										40			37	36		34						30												24				20							15								14						7																																																																																																																																																																																																																																																																																																																																																																																																																										
SALEABLE	NOT APPLICABLE	34576-7433	0	G	BLUE			54	53				49	48	47	46				44	43									40	39	38	37	36	35	34	33	32	31	30	29											26	25	24	23		21	20	19				15											12	11	10	9		7	6	5	4				2	1	SALEABLE	NOT APPLICABLE	34576-7443	0	G	BLUE			54	53				49	48	47					44	43									40	39	38	37	36					32	31	30	29										26	25	24	23		20				17			15										12	11	10	9		7	6	5	4				2	1	SALEABLE	NOT APPLICABLE	34576-7453	9	G	BLUE					52				48	47		45			43										40			37	36		34						30												24				20							15								14						7																																																																																																																																																																																																																																																																																																																																																																																																																																																
								40	39	38	37	36	35	34	33	32	31	30	29											26	25	24	23		21	20	19				15											12	11	10	9		7	6	5	4				2	1	SALEABLE	NOT APPLICABLE	34576-7443	0	G	BLUE			54	53				49	48	47					44	43									40	39	38	37	36					32	31	30	29										26	25	24	23		20				17			15										12	11	10	9		7	6	5	4				2	1	SALEABLE	NOT APPLICABLE	34576-7453	9	G	BLUE					52				48	47		45			43										40			37	36		34						30												24				20							15								14						7																																																																																																																																																																																																																																																																																																																																																																																																																																																																						
								26	25	24	23		21	20	19				15											12	11	10	9		7	6	5	4				2	1	SALEABLE	NOT APPLICABLE	34576-7443	0	G	BLUE			54	53				49	48	47					44	43									40	39	38	37	36					32	31	30	29										26	25	24	23		20				17			15										12	11	10	9		7	6	5	4				2	1	SALEABLE	NOT APPLICABLE	34576-7453	9	G	BLUE					52				48	47		45			43										40			37	36		34						30												24				20							15								14						7																																																																																																																																																																																																																																																																																																																																																																																																																																																																																												
								12	11	10	9		7	6	5	4				2	1	SALEABLE	NOT APPLICABLE	34576-7443	0	G	BLUE			54	53				49	48	47					44	43									40	39	38	37	36					32	31	30	29										26	25	24	23		20				17			15										12	11	10	9		7	6	5	4				2	1	SALEABLE	NOT APPLICABLE	34576-7453	9	G	BLUE					52				48	47		45			43										40			37	36		34						30												24				20							15								14						7																																																																																																																																																																																																																																																																																																																																																																																																																																																																																																																		
SALEABLE	NOT APPLICABLE	34576-7443	0	G	BLUE			54	53				49	48	47					44	43									40	39	38	37	36					32	31	30	29										26	25	24	23		20				17			15										12	11	10	9		7	6	5	4				2	1	SALEABLE	NOT APPLICABLE	34576-7453	9	G	BLUE					52				48	47		45			43										40			37	36		34						30												24				20							15								14						7																																																																																																																																																																																																																																																																																																																																																																																																																																																																																																																																								
								40	39	38	37	36					32	31	30	29										26	25	24	23		20				17			15										12	11	10	9		7	6	5	4				2	1	SALEABLE	NOT APPLICABLE	34576-7453	9	G	BLUE					52				48	47		45			43										40			37	36		34						30												24				20							15								14						7																																																																																																																																																																																																																																																																																																																																																																																																																																																																																																																																																														
								26	25	24	23		20				17			15										12	11	10	9		7	6	5	4				2	1	SALEABLE	NOT APPLICABLE	34576-7453	9	G	BLUE					52				48	47		45			43										40			37	36		34						30												24				20							15								14						7																																																																																																																																																																																																																																																																																																																																																																																																																																																																																																																																																																																				
								12	11	10	9		7	6	5	4				2	1	SALEABLE	NOT APPLICABLE	34576-7453	9	G	BLUE					52				48	47		45			43										40			37	36		34						30												24				20							15								14						7																																																																																																																																																																																																																																																																																																																																																																																																																																																																																																																																																																																																										
SALEABLE	NOT APPLICABLE	34576-7453	9	G	BLUE					52				48	47		45			43										40			37	36		34						30												24				20							15								14						7																																																																																																																																																																																																																																																																																																																																																																																																																																																																																																																																																																																																																																
								40			37	36		34						30												24				20							15								14						7																																																																																																																																																																																																																																																																																																																																																																																																																																																																																																																																																																																																																																																						
										24				20							15								14						7																																																																																																																																																																																																																																																																																																																																																																																																																																																																																																																																																																																																																																																																												
							14						7																																																																																																																																																																																																																																																																																																																																																																																																																																																																																																																																																																																																																																																																																																		



MX123 18/28/42/49/56-WAY RECEPTACLE ASSY SEALED PIN OUT SHEET

STATUS	GM PART #	HRNS CONN ASSY			TPA GROMMET CAP																											
		MATERIAL/PART	WIRE DRESS OPTION	KEY OPTION ▽ Fp	COLOR OPTION ▽ Fp	NUMBERS INDICATE CAVITIES OPEN FOR CIRCUITS ▽ Fp																										
		NUMBER																														
SALEABLE	NOT APPLICABLE	34576-7463	9	G	BLUE														33			31										
																				24	23	22	21	20	19	18				16		
																				10	9	8	7	6						2		
SALEABLE	NOT APPLICABLE	34576-7473	9	G	BLUE	56	55	54	53			51	50	49									46							44		
						42	41		39	38					35								33	32	31					29		
						28	27	26	25			23	22	21									19	18	17	16						
								13	12	11	10	9	8				6	5	4	3	2	1										
SALEABLE	NOT APPLICABLE	34576-7483	0	G	BLUE	56	55			52	51	50													45							
						42	41								35	34		33														
						28	27																									
						14	13																	4	3							
SALEABLE	NOT APPLICABLE	34576-7493	0	G	BLUE	56	55	54	53	52	51	50													45							
						42	41	40	39																							
						28	27																									
						14	13																									
SALEABLE	NOT APPLICABLE	34576-7503	0	G	BLUE	56	55			52	51	50													45							
						42	41																									
						28	27																									
						14	13																									
SALEABLE	NOT APPLICABLE	34576-7513	0	G	BLUE	56	55	54	53	52	51	50	49	48	47	46	45	44	43													
						42	41	40	39	38					35	34	33	32	31	30	29											
						28	27	26	25			23	22	21																		
						14	13	12	11	10	9	8			6	5	4	3	2	1												
SALEABLE	NOT APPLICABLE	34576-7523	9	G	BLUE						37	36																				
											24					20																
														7																		
SALEABLE	NOT APPLICABLE	34576-7533	9	G	BLUE	56		54	53	52				49	48	47	46	45							43							
							41	40	39	38						34	33	32	31	30	29											
						28	27	26	25	24	23					20	19	18														
							13	12	11	10	9	8																				
SALEABLE	NOT APPLICABLE	34576-7543	9	G	BLUE	56		54	53	52					48	47	46	45							43							
							41	40	39	38						34	33	32	31	30	29											
						28	27	26	25	24	23					20	19	18														
							13	12	11	10	9	8																				



MX123 18/28/42/49/56-WAY RECEPTACLE ASSY SEALED PIN OUT SHEET

STATUS	GM PART #	HRNS CONN ASSY			TPA GROMMET CAP															
		MATERIAL/PART	WIRE DRESS OPTION	KEY OPTION ▽ Fp	COLOR OPTION ▽ Fp	NUMBERS INDICATE CAVITIES OPEN FOR CIRCUITS ▽ Fp														
		NUMBER																		
SALEABLE	NOT APPLICABLE	34576-7553	0	A	BLACK	48		46		44	43			40	39	38			35	
						34	33	32	31		29			26	25	24	23			21
						49						8	7					3		11
SALEABLE	NOT APPLICABLE	34576-7563	0	C	BLUE	48	47	46	45	44			41	40	39	38	37	36		
						34	33	32		30						24	23		21	
						49						18	17	16	15	14	13	12		
SALEABLE	NOT APPLICABLE	34576-7573	0	G	BLUE					52	51	50					45	43		
												35	34	33	32					
						28	27	26								18			15	
SALEABLE	NOT APPLICABLE	34576-7583	0	G	BLUE	14	13	12					7	6			3	1		
										52	51	50					45	43		
																32				
SALEABLE	NOT APPLICABLE	34576-7593	0	G	BLUE	28	27	26								18		15		
						14	13	12					7	6			3	1		
										52	51	50					45	43		
SALEABLE	NOT APPLICABLE	34576-7603	0	G	BLUE					52	51	50					45	44	43	
						42	41				37	36	35	34	33	32			30	
						28	27	26		24		22		20	19				16	15
SALEABLE	NOT APPLICABLE	34576-7613	9	C	BLUE	14	13	12		10		8	7	6				1		
						48	47		45	44			41	40	39	38	37	36		
						34	33	32		30						24	23		21	
SALEABLE	NOT APPLICABLE	34576-7623	9	A	BLACK	49						18	17	16	15	14	13	12	1	
										10	9	8	7	6	5		3	2		
						48		46		44	43	42		40	39	38			35	
SALEABLE	NOT APPLICABLE	34576-7633	0	A	BLACK	34	33	32	31		29	28		26	25	24	23		21	
						49						8	7					3	1	
						48	47	46	45	44			41	40	39	38	37	36		
SALEABLE	NOT APPLICABLE	34576-7633	0	A	BLACK	34	33	32		30						24	23		21	
						49						18	17	16	15	14	13	12		
										10	9	8	7	6	5		3	2	1	



MX123 18/28/42/49/56-WAY RECEPTACLE ASSY SEALED PIN OUT SHEET

STATUS	GM PART #	HRNS CONN ASSY			TPA GROMMET CAP																	
		MATERIAL/PART	WIRE DRESS OPTION	KEY OPTION ▽ Fp	COLOR OPTION ▽ Fp	NUMBERS INDICATE CAVITIES OPEN FOR CIRCUITS ▽ Fp																
		NUMBER																				
SALEABLE	NOT APPLICABLE	34576-7643	0	G	BLUE	42	41												30	29		
						28		26			23			20			17					15
						14					9											
SALEABLE	NOT APPLICABLE	34576-7653	0	C	BLUE	48	47	46	45						40		38	37	36			
						34		32	31		29				25	24	23	22				
						49				20	19	18	17	16						12		
						10	9						5				2	1				
SALEABLE	NOT APPLICABLE	34576-7663	9	A	BLACK	48	47	46	45					40		38	37	36				
						34		32	31		29				25	24	23	22				
						49				20	19	18	17	16						12		
						10	9					5				2	1					
SALEABLE	NOT APPLICABLE	34576-7673	0	C	BLUE	48	47	46	45	44			41	40	39	38	37	36				
						34	33	32		30		28	27			24	23				21	
						49				10	9	8	7	6	5			15	14	13	12	
																3	2	1				
SALEABLE	NOT APPLICABLE	34576-7683	0	A	BLACK	48		46		44	43	42			39	38			35			
						34		32	31		29	28			25	24	23				21	
						49				20	19						14					11
						10	9	8	7							3		1				
						52	51	50							46	45		43				
SALEABLE	NOT APPLICABLE	34576-7693	0	G	BLUE											32						
						28	27	26								18				15		
						14	13	12					7	6				3				1
SALEABLE	NOT APPLICABLE	34576-7703	0	G	BLUE					52	51	50				46	45		43			
														35	34	33	32					
						28	27	26									18					
																3		1				
SALEABLE	NOT APPLICABLE	34576-7713	0	G	BLUE					52	51	50				46	45		43			
														35	34	33	32					
						28	27	26									18					
																4	3	1				
SALEABLE	NOT APPLICABLE	34576-7723	9	C	BLUE	48	47	46	45	44			41	40	39	38	37	36				
						34	33	32		30						24	23					
						49						18	17	16	15	14	13	12				
						10	9	8	7	6	5				3	2		1				



MX123 18/28/42/49/56-WAY RECEPTACLE ASSY SEALED PIN OUT SHEET

STATUS	GM PART #	HRNS CONN ASSY			TPA GROMMET CAP																
		MATERIAL/PART	WIRE DRESS OPTION	KEY OPTION ▽ Fp	COLOR OPTION ▽ Fp	NUMBERS INDICATE CAVITIES OPEN FOR CIRCUITS ▽ Fp															
		NUMBER																			
SALEABLE	NOT APPLICABLE	34576-7733	0	A	BLACK					44	43	42	41		39					35	
								33					30		28	27	26				21
						49						18	17		15	14	13				11
											8	7	6		4	3					1
SALEABLE	NOT APPLICABLE	34576-7743	0	C	BLUE						43										
									31		29			26	25						22
						49				20	19										11
										52	51	50				4					2
SALEABLE	NOT APPLICABLE	34576-7753	0	G	BLUE										33	46	45				
						28	27						21			18	17				
						14	13										3				
SALEABLE	NOT APPLICABLE	34576-7763	9	A	BLACK					44	43	42	41		39						35
								33		30		28	27	26							21
						49						18	17			14	13				11
											8	7	6		4	3					
SALEABLE	NOT APPLICABLE	34576-7773	9	A	BLACK	48	47	46	45	44	43			40		38	37	36			
						34		32	31		29	28	27		25	24	23	22			
						49				20	19			16	15						12
										10	9				5						1
SALEABLE	NOT APPLICABLE	34851-0031	9	H	ST. GRAY	18						16	15		1						
											13	12									
											9	8	7	6							
											5										
SALEABLE	NOT APPLICABLE	34576-7783	9	C	BLUE	48	47	46	45	44			41	40	39	38	37	36			
						34	33	32	31		30		27			24	23	22			21
						49						18	17		15	14	13	12			
										10	9	8	7	6	5		3	2	1		
SALEABLE	NOT APPLICABLE	34576-7793	9	A	BLACK	48	47	46	45					40		38	37	36			
						34		32	31						25	24	23	22			
						49				20	19	18	17	16	15						12
										10	9				5						1
SALEABLE	NOT APPLICABLE	34576-7803	0	G	BLUE			54	53				49	48	47					44	43
								40	39	38	37	36	35	34		32	31	30			29
								26	25	24	23	22		20	19						15
								12	11	10	9	8	7	6	5	4				2	1



MX123 18/28/42/49/56-WAY RECEPTACLE ASSY SEALED PIN OUT SHEET

STATUS	GM PART #	HRNS CONN ASSY			TPA GROMMET CAP																																																																																																																																																																																																																																																																																																																																																																																																																																																																																																																																																																																																																																																																																																																																																									
		MATERIAL/PART	WIRE DRESS OPTION	KEY OPTION	COLOR OPTION	NUMBERS INDICATE CAVITIES OPEN FOR CIRCUITS																																																																																																																																																																																																																																																																																																																																																																																																																																																																																																																																																																																																																																																																																																																																																								
		NUMBER		OPTION																																																																																																																																																																																																																																																																																																																																																																																																																																																																																																																																																																																																																																																																																																																																																										
SALEABLE	NOT APPLICABLE	34576-7813	9	C	BLUE	48	47	46	45	44			41	40	39	38	37	36									34	33	32		30			27			24	23		21								49				10	9	8	7		15	14	13	12		1	SALEABLE	NOT APPLICABLE	34576-7823	0	A	BLACK	48	47	46	45					40		38	37	36									34		32	31		29				25	24	23	22									49				20	19		17	16				12													10	9				5			2			SALEABLE	NOT APPLICABLE	34576-7833	0	C	BLUE	48	47		45	44			41	40	39	38	37	36	35								34		32		30		28				24			21								49						18	17		15	14	13	12	11													9		7	6	5		3		1		SALEABLE	NOT APPLICABLE	34576-7843	9	A	BLACK	48	47	46	45	44	43			40		38	37	36									34		32	31			28	27		25	24	23	22									49				20	19	18	17	16	15			12													10	9			6	5			2	1		SALEABLE	NOT APPLICABLE	34576-7853	0	C	BLUE	48	47	46	45	44		42	41	40	39	38	37	36	35								34	33	32		30	29	28	27			24	23		21								49				20		18	17	16	15	14	13	12													10	9	8	7	6	5		3		1		SALEABLE	NOT APPLICABLE	34576-7863	9	A	BLACK	48		46			43				39	38		36	35								34	33		31		29		27		25	24	23		21								49				20	19							11													10	9		7	6				1			SALEABLE	NOT APPLICABLE	34576-7873	9	C	BLUE	48	47	46	45	44	43		41	40	39	38	37	36									34	33	32		30			27			24	23		21								49						18	17		15	14	13	12														9	8	7	6	5		3		1		SALEABLE	NOT APPLICABLE	34576-7883	9	A	BLACK	48	47	46	45	44	43			40			37	36									34		32	31		29		27		25	24	23	22									49				20	19	18		16				12													10	9			6	5			2	1		SALEABLE	NOT APPLICABLE	34576-7893	9	A	BLACK	48	47	46	45					40		38	37	36									34		32	31		29				25	24	23	22									49				20	19		17	16																	10	9			5				2		
						34	33	32		30			27			24	23		21								49				10	9	8	7		15	14	13	12		1	SALEABLE	NOT APPLICABLE	34576-7823	0	A	BLACK	48	47	46	45					40		38	37	36									34		32	31		29				25	24	23	22									49				20	19		17	16				12													10	9				5			2			SALEABLE	NOT APPLICABLE	34576-7833	0	C	BLUE	48	47		45	44			41	40	39	38	37	36	35								34		32		30		28				24			21								49						18	17		15	14	13	12	11													9		7	6	5		3		1		SALEABLE	NOT APPLICABLE	34576-7843	9	A	BLACK	48	47	46	45	44	43			40		38	37	36									34		32	31			28	27		25	24	23	22									49				20	19	18	17	16	15			12													10	9			6	5			2	1		SALEABLE	NOT APPLICABLE	34576-7853	0	C	BLUE	48	47	46	45	44		42	41	40	39	38	37	36	35								34	33	32		30	29	28	27			24	23		21								49				20		18	17	16	15	14	13	12													10	9	8	7	6	5		3		1		SALEABLE	NOT APPLICABLE	34576-7863	9	A	BLACK	48		46			43				39	38		36	35								34	33		31		29		27		25	24	23		21								49				20	19							11													10	9		7	6				1			SALEABLE	NOT APPLICABLE	34576-7873	9	C	BLUE	48	47	46	45	44	43		41	40	39	38	37	36									34	33	32		30			27			24	23		21								49						18	17		15	14	13	12														9	8	7	6	5		3		1		SALEABLE	NOT APPLICABLE	34576-7883	9	A	BLACK	48	47	46	45	44	43			40			37	36									34		32	31		29		27		25	24	23	22									49				20	19	18		16				12													10	9			6	5			2	1		SALEABLE	NOT APPLICABLE	34576-7893	9	A	BLACK	48	47	46	45					40		38	37	36									34		32	31		29				25	24	23	22									49				20	19		17	16																	10	9			5				2																							
						49				10	9	8	7		15	14	13	12		1	SALEABLE	NOT APPLICABLE	34576-7823	0	A	BLACK	48	47	46	45					40		38	37	36									34		32	31		29				25	24	23	22									49				20	19		17	16				12													10	9				5			2			SALEABLE	NOT APPLICABLE	34576-7833	0	C	BLUE	48	47		45	44			41	40	39	38	37	36	35								34		32		30		28				24			21								49						18	17		15	14	13	12	11													9		7	6	5		3		1		SALEABLE	NOT APPLICABLE	34576-7843	9	A	BLACK	48	47	46	45	44	43			40		38	37	36									34		32	31			28	27		25	24	23	22									49				20	19	18	17	16	15			12													10	9			6	5			2	1		SALEABLE	NOT APPLICABLE	34576-7853	0	C	BLUE	48	47	46	45	44		42	41	40	39	38	37	36	35								34	33	32		30	29	28	27			24	23		21								49				20		18	17	16	15	14	13	12													10	9	8	7	6	5		3		1		SALEABLE	NOT APPLICABLE	34576-7863	9	A	BLACK	48		46			43				39	38		36	35								34	33		31		29		27		25	24	23		21								49				20	19							11													10	9		7	6				1			SALEABLE	NOT APPLICABLE	34576-7873	9	C	BLUE	48	47	46	45	44	43		41	40	39	38	37	36									34	33	32		30			27			24	23		21								49						18	17		15	14	13	12														9	8	7	6	5		3		1		SALEABLE	NOT APPLICABLE	34576-7883	9	A	BLACK	48	47	46	45	44	43			40			37	36									34		32	31		29		27		25	24	23	22									49				20	19	18		16				12													10	9			6	5			2	1		SALEABLE	NOT APPLICABLE	34576-7893	9	A	BLACK	48	47	46	45					40		38	37	36									34		32	31		29				25	24	23	22									49				20	19		17	16																	10	9			5				2																																												
SALEABLE	NOT APPLICABLE	34576-7823	0	A	BLACK	48	47	46	45					40		38	37	36									34		32	31		29				25	24	23	22									49				20	19		17	16				12													10	9				5			2			SALEABLE	NOT APPLICABLE	34576-7833	0	C	BLUE	48	47		45	44			41	40	39	38	37	36	35								34		32		30		28				24			21								49						18	17		15	14	13	12	11													9		7	6	5		3		1		SALEABLE	NOT APPLICABLE	34576-7843	9	A	BLACK	48	47	46	45	44	43			40		38	37	36									34		32	31			28	27		25	24	23	22									49				20	19	18	17	16	15			12													10	9			6	5			2	1		SALEABLE	NOT APPLICABLE	34576-7853	0	C	BLUE	48	47	46	45	44		42	41	40	39	38	37	36	35								34	33	32		30	29	28	27			24	23		21								49				20		18	17	16	15	14	13	12													10	9	8	7	6	5		3		1		SALEABLE	NOT APPLICABLE	34576-7863	9	A	BLACK	48		46			43				39	38		36	35								34	33		31		29		27		25	24	23		21								49				20	19							11													10	9		7	6				1			SALEABLE	NOT APPLICABLE	34576-7873	9	C	BLUE	48	47	46	45	44	43		41	40	39	38	37	36									34	33	32		30			27			24	23		21								49						18	17		15	14	13	12														9	8	7	6	5		3		1		SALEABLE	NOT APPLICABLE	34576-7883	9	A	BLACK	48	47	46	45	44	43			40			37	36									34		32	31		29		27		25	24	23	22									49				20	19	18		16				12													10	9			6	5			2	1		SALEABLE	NOT APPLICABLE	34576-7893	9	A	BLACK	48	47	46	45					40		38	37	36									34		32	31		29				25	24	23	22									49				20	19		17	16																	10	9			5				2																																																																	
						34		32	31		29				25	24	23	22									49				20	19		17	16				12													10	9				5			2			SALEABLE	NOT APPLICABLE	34576-7833	0	C	BLUE	48	47		45	44			41	40	39	38	37	36	35								34		32		30		28				24			21								49						18	17		15	14	13	12	11													9		7	6	5		3		1		SALEABLE	NOT APPLICABLE	34576-7843	9	A	BLACK	48	47	46	45	44	43			40		38	37	36									34		32	31			28	27		25	24	23	22									49				20	19	18	17	16	15			12													10	9			6	5			2	1		SALEABLE	NOT APPLICABLE	34576-7853	0	C	BLUE	48	47	46	45	44		42	41	40	39	38	37	36	35								34	33	32		30	29	28	27			24	23		21								49				20		18	17	16	15	14	13	12													10	9	8	7	6	5		3		1		SALEABLE	NOT APPLICABLE	34576-7863	9	A	BLACK	48		46			43				39	38		36	35								34	33		31		29		27		25	24	23		21								49				20	19							11													10	9		7	6				1			SALEABLE	NOT APPLICABLE	34576-7873	9	C	BLUE	48	47	46	45	44	43		41	40	39	38	37	36									34	33	32		30			27			24	23		21								49						18	17		15	14	13	12														9	8	7	6	5		3		1		SALEABLE	NOT APPLICABLE	34576-7883	9	A	BLACK	48	47	46	45	44	43			40			37	36									34		32	31		29		27		25	24	23	22									49				20	19	18		16				12													10	9			6	5			2	1		SALEABLE	NOT APPLICABLE	34576-7893	9	A	BLACK	48	47	46	45					40		38	37	36									34		32	31		29				25	24	23	22									49				20	19		17	16																	10	9			5				2																																																																																						
						49				20	19		17	16				12													10	9				5			2			SALEABLE	NOT APPLICABLE	34576-7833	0	C	BLUE	48	47		45	44			41	40	39	38	37	36	35								34		32		30		28				24			21								49						18	17		15	14	13	12	11													9		7	6	5		3		1		SALEABLE	NOT APPLICABLE	34576-7843	9	A	BLACK	48	47	46	45	44	43			40		38	37	36									34		32	31			28	27		25	24	23	22									49				20	19	18	17	16	15			12													10	9			6	5			2	1		SALEABLE	NOT APPLICABLE	34576-7853	0	C	BLUE	48	47	46	45	44		42	41	40	39	38	37	36	35								34	33	32		30	29	28	27			24	23		21								49				20		18	17	16	15	14	13	12													10	9	8	7	6	5		3		1		SALEABLE	NOT APPLICABLE	34576-7863	9	A	BLACK	48		46			43				39	38		36	35								34	33		31		29		27		25	24	23		21								49				20	19							11													10	9		7	6				1			SALEABLE	NOT APPLICABLE	34576-7873	9	C	BLUE	48	47	46	45	44	43		41	40	39	38	37	36									34	33	32		30			27			24	23		21								49						18	17		15	14	13	12														9	8	7	6	5		3		1		SALEABLE	NOT APPLICABLE	34576-7883	9	A	BLACK	48	47	46	45	44	43			40			37	36									34		32	31		29		27		25	24	23	22									49				20	19	18		16				12													10	9			6	5			2	1		SALEABLE	NOT APPLICABLE	34576-7893	9	A	BLACK	48	47	46	45					40		38	37	36									34		32	31		29				25	24	23	22									49				20	19		17	16																	10	9			5				2																																																																																																											
										10	9				5			2			SALEABLE	NOT APPLICABLE	34576-7833	0	C	BLUE	48	47		45	44			41	40	39	38	37	36	35								34		32		30		28				24			21								49						18	17		15	14	13	12	11													9		7	6	5		3		1		SALEABLE	NOT APPLICABLE	34576-7843	9	A	BLACK	48	47	46	45	44	43			40		38	37	36									34		32	31			28	27		25	24	23	22									49				20	19	18	17	16	15			12													10	9			6	5			2	1		SALEABLE	NOT APPLICABLE	34576-7853	0	C	BLUE	48	47	46	45	44		42	41	40	39	38	37	36	35								34	33	32		30	29	28	27			24	23		21								49				20		18	17	16	15	14	13	12													10	9	8	7	6	5		3		1		SALEABLE	NOT APPLICABLE	34576-7863	9	A	BLACK	48		46			43				39	38		36	35								34	33		31		29		27		25	24	23		21								49				20	19							11													10	9		7	6				1			SALEABLE	NOT APPLICABLE	34576-7873	9	C	BLUE	48	47	46	45	44	43		41	40	39	38	37	36									34	33	32		30			27			24	23		21								49						18	17		15	14	13	12														9	8	7	6	5		3		1		SALEABLE	NOT APPLICABLE	34576-7883	9	A	BLACK	48	47	46	45	44	43			40			37	36									34		32	31		29		27		25	24	23	22									49				20	19	18		16				12													10	9			6	5			2	1		SALEABLE	NOT APPLICABLE	34576-7893	9	A	BLACK	48	47	46	45					40		38	37	36									34		32	31		29				25	24	23	22									49				20	19		17	16																	10	9			5				2																																																																																																																																
SALEABLE	NOT APPLICABLE	34576-7833	0	C	BLUE	48	47		45	44			41	40	39	38	37	36	35								34		32		30		28				24			21								49						18	17		15	14	13	12	11													9		7	6	5		3		1		SALEABLE	NOT APPLICABLE	34576-7843	9	A	BLACK	48	47	46	45	44	43			40		38	37	36									34		32	31			28	27		25	24	23	22									49				20	19	18	17	16	15			12													10	9			6	5			2	1		SALEABLE	NOT APPLICABLE	34576-7853	0	C	BLUE	48	47	46	45	44		42	41	40	39	38	37	36	35								34	33	32		30	29	28	27			24	23		21								49				20		18	17	16	15	14	13	12													10	9	8	7	6	5		3		1		SALEABLE	NOT APPLICABLE	34576-7863	9	A	BLACK	48		46			43				39	38		36	35								34	33		31		29		27		25	24	23		21								49				20	19							11													10	9		7	6				1			SALEABLE	NOT APPLICABLE	34576-7873	9	C	BLUE	48	47	46	45	44	43		41	40	39	38	37	36									34	33	32		30			27			24	23		21								49						18	17		15	14	13	12														9	8	7	6	5		3		1		SALEABLE	NOT APPLICABLE	34576-7883	9	A	BLACK	48	47	46	45	44	43			40			37	36									34		32	31		29		27		25	24	23	22									49				20	19	18		16				12													10	9			6	5			2	1		SALEABLE	NOT APPLICABLE	34576-7893	9	A	BLACK	48	47	46	45					40		38	37	36									34		32	31		29				25	24	23	22									49				20	19		17	16																	10	9			5				2																																																																																																																																																					
						34		32		30		28				24			21								49						18	17		15	14	13	12	11													9		7	6	5		3		1		SALEABLE	NOT APPLICABLE	34576-7843	9	A	BLACK	48	47	46	45	44	43			40		38	37	36									34		32	31			28	27		25	24	23	22									49				20	19	18	17	16	15			12													10	9			6	5			2	1		SALEABLE	NOT APPLICABLE	34576-7853	0	C	BLUE	48	47	46	45	44		42	41	40	39	38	37	36	35								34	33	32		30	29	28	27			24	23		21								49				20		18	17	16	15	14	13	12													10	9	8	7	6	5		3		1		SALEABLE	NOT APPLICABLE	34576-7863	9	A	BLACK	48		46			43				39	38		36	35								34	33		31		29		27		25	24	23		21								49				20	19							11													10	9		7	6				1			SALEABLE	NOT APPLICABLE	34576-7873	9	C	BLUE	48	47	46	45	44	43		41	40	39	38	37	36									34	33	32		30			27			24	23		21								49						18	17		15	14	13	12														9	8	7	6	5		3		1		SALEABLE	NOT APPLICABLE	34576-7883	9	A	BLACK	48	47	46	45	44	43			40			37	36									34		32	31		29		27		25	24	23	22									49				20	19	18		16				12													10	9			6	5			2	1		SALEABLE	NOT APPLICABLE	34576-7893	9	A	BLACK	48	47	46	45					40		38	37	36									34		32	31		29				25	24	23	22									49				20	19		17	16																	10	9			5				2																																																																																																																																																																										
						49						18	17		15	14	13	12	11													9		7	6	5		3		1		SALEABLE	NOT APPLICABLE	34576-7843	9	A	BLACK	48	47	46	45	44	43			40		38	37	36									34		32	31			28	27		25	24	23	22									49				20	19	18	17	16	15			12													10	9			6	5			2	1		SALEABLE	NOT APPLICABLE	34576-7853	0	C	BLUE	48	47	46	45	44		42	41	40	39	38	37	36	35								34	33	32		30	29	28	27			24	23		21								49				20		18	17	16	15	14	13	12													10	9	8	7	6	5		3		1		SALEABLE	NOT APPLICABLE	34576-7863	9	A	BLACK	48		46			43				39	38		36	35								34	33		31		29		27		25	24	23		21								49				20	19							11													10	9		7	6				1			SALEABLE	NOT APPLICABLE	34576-7873	9	C	BLUE	48	47	46	45	44	43		41	40	39	38	37	36									34	33	32		30			27			24	23		21								49						18	17		15	14	13	12														9	8	7	6	5		3		1		SALEABLE	NOT APPLICABLE	34576-7883	9	A	BLACK	48	47	46	45	44	43			40			37	36									34		32	31		29		27		25	24	23	22									49				20	19	18		16				12													10	9			6	5			2	1		SALEABLE	NOT APPLICABLE	34576-7893	9	A	BLACK	48	47	46	45					40		38	37	36									34		32	31		29				25	24	23	22									49				20	19		17	16																	10	9			5				2																																																																																																																																																																																															
											9		7	6	5		3		1		SALEABLE	NOT APPLICABLE	34576-7843	9	A	BLACK	48	47	46	45	44	43			40		38	37	36									34		32	31			28	27		25	24	23	22									49				20	19	18	17	16	15			12													10	9			6	5			2	1		SALEABLE	NOT APPLICABLE	34576-7853	0	C	BLUE	48	47	46	45	44		42	41	40	39	38	37	36	35								34	33	32		30	29	28	27			24	23		21								49				20		18	17	16	15	14	13	12													10	9	8	7	6	5		3		1		SALEABLE	NOT APPLICABLE	34576-7863	9	A	BLACK	48		46			43				39	38		36	35								34	33		31		29		27		25	24	23		21								49				20	19							11													10	9		7	6				1			SALEABLE	NOT APPLICABLE	34576-7873	9	C	BLUE	48	47	46	45	44	43		41	40	39	38	37	36									34	33	32		30			27			24	23		21								49						18	17		15	14	13	12														9	8	7	6	5		3		1		SALEABLE	NOT APPLICABLE	34576-7883	9	A	BLACK	48	47	46	45	44	43			40			37	36									34		32	31		29		27		25	24	23	22									49				20	19	18		16				12													10	9			6	5			2	1		SALEABLE	NOT APPLICABLE	34576-7893	9	A	BLACK	48	47	46	45					40		38	37	36									34		32	31		29				25	24	23	22									49				20	19		17	16																	10	9			5				2																																																																																																																																																																																																																				
SALEABLE	NOT APPLICABLE	34576-7843	9	A	BLACK	48	47	46	45	44	43			40		38	37	36									34		32	31			28	27		25	24	23	22									49				20	19	18	17	16	15			12													10	9			6	5			2	1		SALEABLE	NOT APPLICABLE	34576-7853	0	C	BLUE	48	47	46	45	44		42	41	40	39	38	37	36	35								34	33	32		30	29	28	27			24	23		21								49				20		18	17	16	15	14	13	12													10	9	8	7	6	5		3		1		SALEABLE	NOT APPLICABLE	34576-7863	9	A	BLACK	48		46			43				39	38		36	35								34	33		31		29		27		25	24	23		21								49				20	19							11													10	9		7	6				1			SALEABLE	NOT APPLICABLE	34576-7873	9	C	BLUE	48	47	46	45	44	43		41	40	39	38	37	36									34	33	32		30			27			24	23		21								49						18	17		15	14	13	12														9	8	7	6	5		3		1		SALEABLE	NOT APPLICABLE	34576-7883	9	A	BLACK	48	47	46	45	44	43			40			37	36									34		32	31		29		27		25	24	23	22									49				20	19	18		16				12													10	9			6	5			2	1		SALEABLE	NOT APPLICABLE	34576-7893	9	A	BLACK	48	47	46	45					40		38	37	36									34		32	31		29				25	24	23	22									49				20	19		17	16																	10	9			5				2																																																																																																																																																																																																																																									
						34		32	31			28	27		25	24	23	22									49				20	19	18	17	16	15			12													10	9			6	5			2	1		SALEABLE	NOT APPLICABLE	34576-7853	0	C	BLUE	48	47	46	45	44		42	41	40	39	38	37	36	35								34	33	32		30	29	28	27			24	23		21								49				20		18	17	16	15	14	13	12													10	9	8	7	6	5		3		1		SALEABLE	NOT APPLICABLE	34576-7863	9	A	BLACK	48		46			43				39	38		36	35								34	33		31		29		27		25	24	23		21								49				20	19							11													10	9		7	6				1			SALEABLE	NOT APPLICABLE	34576-7873	9	C	BLUE	48	47	46	45	44	43		41	40	39	38	37	36									34	33	32		30			27			24	23		21								49						18	17		15	14	13	12														9	8	7	6	5		3		1		SALEABLE	NOT APPLICABLE	34576-7883	9	A	BLACK	48	47	46	45	44	43			40			37	36									34		32	31		29		27		25	24	23	22									49				20	19	18		16				12													10	9			6	5			2	1		SALEABLE	NOT APPLICABLE	34576-7893	9	A	BLACK	48	47	46	45					40		38	37	36									34		32	31		29				25	24	23	22									49				20	19		17	16																	10	9			5				2																																																																																																																																																																																																																																																														
						49				20	19	18	17	16	15			12													10	9			6	5			2	1		SALEABLE	NOT APPLICABLE	34576-7853	0	C	BLUE	48	47	46	45	44		42	41	40	39	38	37	36	35								34	33	32		30	29	28	27			24	23		21								49				20		18	17	16	15	14	13	12													10	9	8	7	6	5		3		1		SALEABLE	NOT APPLICABLE	34576-7863	9	A	BLACK	48		46			43				39	38		36	35								34	33		31		29		27		25	24	23		21								49				20	19							11													10	9		7	6				1			SALEABLE	NOT APPLICABLE	34576-7873	9	C	BLUE	48	47	46	45	44	43		41	40	39	38	37	36									34	33	32		30			27			24	23		21								49						18	17		15	14	13	12														9	8	7	6	5		3		1		SALEABLE	NOT APPLICABLE	34576-7883	9	A	BLACK	48	47	46	45	44	43			40			37	36									34		32	31		29		27		25	24	23	22									49				20	19	18		16				12													10	9			6	5			2	1		SALEABLE	NOT APPLICABLE	34576-7893	9	A	BLACK	48	47	46	45					40		38	37	36									34		32	31		29				25	24	23	22									49				20	19		17	16																	10	9			5				2																																																																																																																																																																																																																																																																																			
										10	9			6	5			2	1		SALEABLE	NOT APPLICABLE	34576-7853	0	C	BLUE	48	47	46	45	44		42	41	40	39	38	37	36	35								34	33	32		30	29	28	27			24	23		21								49				20		18	17	16	15	14	13	12													10	9	8	7	6	5		3		1		SALEABLE	NOT APPLICABLE	34576-7863	9	A	BLACK	48		46			43				39	38		36	35								34	33		31		29		27		25	24	23		21								49				20	19							11													10	9		7	6				1			SALEABLE	NOT APPLICABLE	34576-7873	9	C	BLUE	48	47	46	45	44	43		41	40	39	38	37	36									34	33	32		30			27			24	23		21								49						18	17		15	14	13	12														9	8	7	6	5		3		1		SALEABLE	NOT APPLICABLE	34576-7883	9	A	BLACK	48	47	46	45	44	43			40			37	36									34		32	31		29		27		25	24	23	22									49				20	19	18		16				12													10	9			6	5			2	1		SALEABLE	NOT APPLICABLE	34576-7893	9	A	BLACK	48	47	46	45					40		38	37	36									34		32	31		29				25	24	23	22									49				20	19		17	16																	10	9			5				2																																																																																																																																																																																																																																																																																																								
SALEABLE	NOT APPLICABLE	34576-7853	0	C	BLUE	48	47	46	45	44		42	41	40	39	38	37	36	35								34	33	32		30	29	28	27			24	23		21								49				20		18	17	16	15	14	13	12													10	9	8	7	6	5		3		1		SALEABLE	NOT APPLICABLE	34576-7863	9	A	BLACK	48		46			43				39	38		36	35								34	33		31		29		27		25	24	23		21								49				20	19							11													10	9		7	6				1			SALEABLE	NOT APPLICABLE	34576-7873	9	C	BLUE	48	47	46	45	44	43		41	40	39	38	37	36									34	33	32		30			27			24	23		21								49						18	17		15	14	13	12														9	8	7	6	5		3		1		SALEABLE	NOT APPLICABLE	34576-7883	9	A	BLACK	48	47	46	45	44	43			40			37	36									34		32	31		29		27		25	24	23	22									49				20	19	18		16				12													10	9			6	5			2	1		SALEABLE	NOT APPLICABLE	34576-7893	9	A	BLACK	48	47	46	45					40		38	37	36									34		32	31		29				25	24	23	22									49				20	19		17	16																	10	9			5				2																																																																																																																																																																																																																																																																																																																													
						34	33	32		30	29	28	27			24	23		21								49				20		18	17	16	15	14	13	12													10	9	8	7	6	5		3		1		SALEABLE	NOT APPLICABLE	34576-7863	9	A	BLACK	48		46			43				39	38		36	35								34	33		31		29		27		25	24	23		21								49				20	19							11													10	9		7	6				1			SALEABLE	NOT APPLICABLE	34576-7873	9	C	BLUE	48	47	46	45	44	43		41	40	39	38	37	36									34	33	32		30			27			24	23		21								49						18	17		15	14	13	12														9	8	7	6	5		3		1		SALEABLE	NOT APPLICABLE	34576-7883	9	A	BLACK	48	47	46	45	44	43			40			37	36									34		32	31		29		27		25	24	23	22									49				20	19	18		16				12													10	9			6	5			2	1		SALEABLE	NOT APPLICABLE	34576-7893	9	A	BLACK	48	47	46	45					40		38	37	36									34		32	31		29				25	24	23	22									49				20	19		17	16																	10	9			5				2																																																																																																																																																																																																																																																																																																																																																		
						49				20		18	17	16	15	14	13	12													10	9	8	7	6	5		3		1		SALEABLE	NOT APPLICABLE	34576-7863	9	A	BLACK	48		46			43				39	38		36	35								34	33		31		29		27		25	24	23		21								49				20	19							11													10	9		7	6				1			SALEABLE	NOT APPLICABLE	34576-7873	9	C	BLUE	48	47	46	45	44	43		41	40	39	38	37	36									34	33	32		30			27			24	23		21								49						18	17		15	14	13	12														9	8	7	6	5		3		1		SALEABLE	NOT APPLICABLE	34576-7883	9	A	BLACK	48	47	46	45	44	43			40			37	36									34		32	31		29		27		25	24	23	22									49				20	19	18		16				12													10	9			6	5			2	1		SALEABLE	NOT APPLICABLE	34576-7893	9	A	BLACK	48	47	46	45					40		38	37	36									34		32	31		29				25	24	23	22									49				20	19		17	16																	10	9			5				2																																																																																																																																																																																																																																																																																																																																																																							
										10	9	8	7	6	5		3		1		SALEABLE	NOT APPLICABLE	34576-7863	9	A	BLACK	48		46			43				39	38		36	35								34	33		31		29		27		25	24	23		21								49				20	19							11													10	9		7	6				1			SALEABLE	NOT APPLICABLE	34576-7873	9	C	BLUE	48	47	46	45	44	43		41	40	39	38	37	36									34	33	32		30			27			24	23		21								49						18	17		15	14	13	12														9	8	7	6	5		3		1		SALEABLE	NOT APPLICABLE	34576-7883	9	A	BLACK	48	47	46	45	44	43			40			37	36									34		32	31		29		27		25	24	23	22									49				20	19	18		16				12													10	9			6	5			2	1		SALEABLE	NOT APPLICABLE	34576-7893	9	A	BLACK	48	47	46	45					40		38	37	36									34		32	31		29				25	24	23	22									49				20	19		17	16																	10	9			5				2																																																																																																																																																																																																																																																																																																																																																																																												
SALEABLE	NOT APPLICABLE	34576-7863	9	A	BLACK	48		46			43				39	38		36	35								34	33		31		29		27		25	24	23		21								49				20	19							11													10	9		7	6				1			SALEABLE	NOT APPLICABLE	34576-7873	9	C	BLUE	48	47	46	45	44	43		41	40	39	38	37	36									34	33	32		30			27			24	23		21								49						18	17		15	14	13	12														9	8	7	6	5		3		1		SALEABLE	NOT APPLICABLE	34576-7883	9	A	BLACK	48	47	46	45	44	43			40			37	36									34		32	31		29		27		25	24	23	22									49				20	19	18		16				12													10	9			6	5			2	1		SALEABLE	NOT APPLICABLE	34576-7893	9	A	BLACK	48	47	46	45					40		38	37	36									34		32	31		29				25	24	23	22									49				20	19		17	16																	10	9			5				2																																																																																																																																																																																																																																																																																																																																																																																																																	
						34	33		31		29		27		25	24	23		21								49				20	19							11													10	9		7	6				1			SALEABLE	NOT APPLICABLE	34576-7873	9	C	BLUE	48	47	46	45	44	43		41	40	39	38	37	36									34	33	32		30			27			24	23		21								49						18	17		15	14	13	12														9	8	7	6	5		3		1		SALEABLE	NOT APPLICABLE	34576-7883	9	A	BLACK	48	47	46	45	44	43			40			37	36									34		32	31		29		27		25	24	23	22									49				20	19	18		16				12													10	9			6	5			2	1		SALEABLE	NOT APPLICABLE	34576-7893	9	A	BLACK	48	47	46	45					40		38	37	36									34		32	31		29				25	24	23	22									49				20	19		17	16																	10	9			5				2																																																																																																																																																																																																																																																																																																																																																																																																																																						
						49				20	19							11													10	9		7	6				1			SALEABLE	NOT APPLICABLE	34576-7873	9	C	BLUE	48	47	46	45	44	43		41	40	39	38	37	36									34	33	32		30			27			24	23		21								49						18	17		15	14	13	12														9	8	7	6	5		3		1		SALEABLE	NOT APPLICABLE	34576-7883	9	A	BLACK	48	47	46	45	44	43			40			37	36									34		32	31		29		27		25	24	23	22									49				20	19	18		16				12													10	9			6	5			2	1		SALEABLE	NOT APPLICABLE	34576-7893	9	A	BLACK	48	47	46	45					40		38	37	36									34		32	31		29				25	24	23	22									49				20	19		17	16																	10	9			5				2																																																																																																																																																																																																																																																																																																																																																																																																																																																											
										10	9		7	6				1			SALEABLE	NOT APPLICABLE	34576-7873	9	C	BLUE	48	47	46	45	44	43		41	40	39	38	37	36									34	33	32		30			27			24	23		21								49						18	17		15	14	13	12														9	8	7	6	5		3		1		SALEABLE	NOT APPLICABLE	34576-7883	9	A	BLACK	48	47	46	45	44	43			40			37	36									34		32	31		29		27		25	24	23	22									49				20	19	18		16				12													10	9			6	5			2	1		SALEABLE	NOT APPLICABLE	34576-7893	9	A	BLACK	48	47	46	45					40		38	37	36									34		32	31		29				25	24	23	22									49				20	19		17	16																	10	9			5				2																																																																																																																																																																																																																																																																																																																																																																																																																																																																																
SALEABLE	NOT APPLICABLE	34576-7873	9	C	BLUE	48	47	46	45	44	43		41	40	39	38	37	36									34	33	32		30			27			24	23		21								49						18	17		15	14	13	12														9	8	7	6	5		3		1		SALEABLE	NOT APPLICABLE	34576-7883	9	A	BLACK	48	47	46	45	44	43			40			37	36									34		32	31		29		27		25	24	23	22									49				20	19	18		16				12													10	9			6	5			2	1		SALEABLE	NOT APPLICABLE	34576-7893	9	A	BLACK	48	47	46	45					40		38	37	36									34		32	31		29				25	24	23	22									49				20	19		17	16																	10	9			5				2																																																																																																																																																																																																																																																																																																																																																																																																																																																																																																					
						34	33	32		30			27			24	23		21								49						18	17		15	14	13	12														9	8	7	6	5		3		1		SALEABLE	NOT APPLICABLE	34576-7883	9	A	BLACK	48	47	46	45	44	43			40			37	36									34		32	31		29		27		25	24	23	22									49				20	19	18		16				12													10	9			6	5			2	1		SALEABLE	NOT APPLICABLE	34576-7893	9	A	BLACK	48	47	46	45					40		38	37	36									34		32	31		29				25	24	23	22									49				20	19		17	16																	10	9			5				2																																																																																																																																																																																																																																																																																																																																																																																																																																																																																																																										
						49						18	17		15	14	13	12														9	8	7	6	5		3		1		SALEABLE	NOT APPLICABLE	34576-7883	9	A	BLACK	48	47	46	45	44	43			40			37	36									34		32	31		29		27		25	24	23	22									49				20	19	18		16				12													10	9			6	5			2	1		SALEABLE	NOT APPLICABLE	34576-7893	9	A	BLACK	48	47	46	45					40		38	37	36									34		32	31		29				25	24	23	22									49				20	19		17	16																	10	9			5				2																																																																																																																																																																																																																																																																																																																																																																																																																																																																																																																																															
											9	8	7	6	5		3		1		SALEABLE	NOT APPLICABLE	34576-7883	9	A	BLACK	48	47	46	45	44	43			40			37	36									34		32	31		29		27		25	24	23	22									49				20	19	18		16				12													10	9			6	5			2	1		SALEABLE	NOT APPLICABLE	34576-7893	9	A	BLACK	48	47	46	45					40		38	37	36									34		32	31		29				25	24	23	22									49				20	19		17	16																	10	9			5				2																																																																																																																																																																																																																																																																																																																																																																																																																																																																																																																																																																				
SALEABLE	NOT APPLICABLE	34576-7883	9	A	BLACK	48	47	46	45	44	43			40			37	36									34		32	31		29		27		25	24	23	22									49				20	19	18		16				12													10	9			6	5			2	1		SALEABLE	NOT APPLICABLE	34576-7893	9	A	BLACK	48	47	46	45					40		38	37	36									34		32	31		29				25	24	23	22									49				20	19		17	16																	10	9			5				2																																																																																																																																																																																																																																																																																																																																																																																																																																																																																																																																																																																									
						34		32	31		29		27		25	24	23	22									49				20	19	18		16				12													10	9			6	5			2	1		SALEABLE	NOT APPLICABLE	34576-7893	9	A	BLACK	48	47	46	45					40		38	37	36									34		32	31		29				25	24	23	22									49				20	19		17	16																	10	9			5				2																																																																																																																																																																																																																																																																																																																																																																																																																																																																																																																																																																																																														
						49				20	19	18		16				12													10	9			6	5			2	1		SALEABLE	NOT APPLICABLE	34576-7893	9	A	BLACK	48	47	46	45					40		38	37	36									34		32	31		29				25	24	23	22									49				20	19		17	16																	10	9			5				2																																																																																																																																																																																																																																																																																																																																																																																																																																																																																																																																																																																																																																			
										10	9			6	5			2	1		SALEABLE	NOT APPLICABLE	34576-7893	9	A	BLACK	48	47	46	45					40		38	37	36									34		32	31		29				25	24	23	22									49				20	19		17	16																	10	9			5				2																																																																																																																																																																																																																																																																																																																																																																																																																																																																																																																																																																																																																																																								
SALEABLE	NOT APPLICABLE	34576-7893	9	A	BLACK	48	47	46	45					40		38	37	36									34		32	31		29				25	24	23	22									49				20	19		17	16																	10	9			5				2																																																																																																																																																																																																																																																																																																																																																																																																																																																																																																																																																																																																																																																																													
						34		32	31		29				25	24	23	22									49				20	19		17	16																	10	9			5				2																																																																																																																																																																																																																																																																																																																																																																																																																																																																																																																																																																																																																																																																																																		
						49				20	19		17	16																	10	9			5				2																																																																																																																																																																																																																																																																																																																																																																																																																																																																																																																																																																																																																																																																																																																							
										10	9			5				2																																																																																																																																																																																																																																																																																																																																																																																																																																																																																																																																																																																																																																																																																																																																												



MX123 18/28/42/49/56-WAY RECEPTACLE ASSY SEALED PIN OUT SHEET

STATUS	GM PART #	HRNS CONN ASSY			TPA GROMMET CAP																																																																																																																																																																																																																																																																																																																																																																																																																																																																																																																																																																																																																																																																																
		MATERIAL/PART	WIRE DRESS OPTION	KEY OPTION	COLOR OPTION	NUMBERS INDICATE CAVITIES OPEN FOR CIRCUITS																																																																																																																																																																																																																																																																																																																																																																																																																																																																																																																																																																																																																																																																															
		NUMBER		OPTION																																																																																																																																																																																																																																																																																																																																																																																																																																																																																																																																																																																																																																																																																	
SALEABLE	NOT APPLICABLE	34576-7903	0	A	BLACK	48	47	46	45					40		38	37	36								34		32	31			29			25	24	23	22								49				20	19		17	16				12												10	9				5			2	1	SALEABLE	NOT APPLICABLE	34576-7913	9	A	BLACK	48		46				43			39	38		36	35							34	33	32	31			29		27		25	24	23	22	21							49				20	19								11											10	9		7	6					1	SALEABLE	NOT APPLICABLE	34576-7923	0	A	BLACK	48	47	46	45	44	43			40		38	37	36								34		32	31			29	28	27		25	24	23	22							49				20	19	18	17	16	15			12												10	9			6	5			2	1	SALEABLE	NOT APPLICABLE	34576-7933	0	C	BLUE																					49				20		18	17	16		14	13	12													9	8	7	6			3		1	SALEABLE	NOT APPLICABLE	34576-7943	0	A	BLACK	48	47	46	45					40		38	37	36								34		32	31			29			25	24	23	22								49				20	19			16	15			12												10	9				5			2	1	SALEABLE	NOT APPLICABLE	34576-7953	0	G	BLUE					52	51	50				46	45									28	27	26					21		33	18	17									14	13	12									3			SALEABLE	NOT APPLICABLE	34576-7963	9	A	BLACK	48		46				43			39	38		36	35							34	33	32	31			29		27		25	24	23	22	21							49				20	19								11											10	9		7	6					1	SALEABLE	NOT APPLICABLE	34576-7973	0	A	BLACK	48	47	46	45	44	43			40		38	37	36								34		32	31			28	27		25	24	23	22								49				20	19			16	15			12												10	9				5			2	1	SALEABLE	NOT APPLICABLE	34576-7983	9	A	BLACK			32				29	28		26	25	38	23								49				20		18		16	15															10		8	7	6	5				
						34		32	31			29			25	24	23	22								49				20	19		17	16				12												10	9				5			2	1	SALEABLE	NOT APPLICABLE	34576-7913	9	A	BLACK	48		46				43			39	38		36	35							34	33	32	31			29		27		25	24	23	22	21							49				20	19								11											10	9		7	6					1	SALEABLE	NOT APPLICABLE	34576-7923	0	A	BLACK	48	47	46	45	44	43			40		38	37	36								34		32	31			29	28	27		25	24	23	22							49				20	19	18	17	16	15			12												10	9			6	5			2	1	SALEABLE	NOT APPLICABLE	34576-7933	0	C	BLUE																					49				20		18	17	16		14	13	12													9	8	7	6			3		1	SALEABLE	NOT APPLICABLE	34576-7943	0	A	BLACK	48	47	46	45					40		38	37	36								34		32	31			29			25	24	23	22								49				20	19			16	15			12												10	9				5			2	1	SALEABLE	NOT APPLICABLE	34576-7953	0	G	BLUE					52	51	50				46	45									28	27	26					21		33	18	17									14	13	12									3			SALEABLE	NOT APPLICABLE	34576-7963	9	A	BLACK	48		46				43			39	38		36	35							34	33	32	31			29		27		25	24	23	22	21							49				20	19								11											10	9		7	6					1	SALEABLE	NOT APPLICABLE	34576-7973	0	A	BLACK	48	47	46	45	44	43			40		38	37	36								34		32	31			28	27		25	24	23	22								49				20	19			16	15			12												10	9				5			2	1	SALEABLE	NOT APPLICABLE	34576-7983	9	A	BLACK			32				29	28		26	25	38	23								49				20		18		16	15															10		8	7	6	5																								
						49				20	19		17	16				12												10	9				5			2	1	SALEABLE	NOT APPLICABLE	34576-7913	9	A	BLACK	48		46				43			39	38		36	35							34	33	32	31			29		27		25	24	23	22	21							49				20	19								11											10	9		7	6					1	SALEABLE	NOT APPLICABLE	34576-7923	0	A	BLACK	48	47	46	45	44	43			40		38	37	36								34		32	31			29	28	27		25	24	23	22							49				20	19	18	17	16	15			12												10	9			6	5			2	1	SALEABLE	NOT APPLICABLE	34576-7933	0	C	BLUE																					49				20		18	17	16		14	13	12													9	8	7	6			3		1	SALEABLE	NOT APPLICABLE	34576-7943	0	A	BLACK	48	47	46	45					40		38	37	36								34		32	31			29			25	24	23	22								49				20	19			16	15			12												10	9				5			2	1	SALEABLE	NOT APPLICABLE	34576-7953	0	G	BLUE					52	51	50				46	45									28	27	26					21		33	18	17									14	13	12									3			SALEABLE	NOT APPLICABLE	34576-7963	9	A	BLACK	48		46				43			39	38		36	35							34	33	32	31			29		27		25	24	23	22	21							49				20	19								11											10	9		7	6					1	SALEABLE	NOT APPLICABLE	34576-7973	0	A	BLACK	48	47	46	45	44	43			40		38	37	36								34		32	31			28	27		25	24	23	22								49				20	19			16	15			12												10	9				5			2	1	SALEABLE	NOT APPLICABLE	34576-7983	9	A	BLACK			32				29	28		26	25	38	23								49				20		18		16	15															10		8	7	6	5																																												
										10	9				5			2	1	SALEABLE	NOT APPLICABLE	34576-7913	9	A	BLACK	48		46				43			39	38		36	35							34	33	32	31			29		27		25	24	23	22	21							49				20	19								11											10	9		7	6					1	SALEABLE	NOT APPLICABLE	34576-7923	0	A	BLACK	48	47	46	45	44	43			40		38	37	36								34		32	31			29	28	27		25	24	23	22							49				20	19	18	17	16	15			12												10	9			6	5			2	1	SALEABLE	NOT APPLICABLE	34576-7933	0	C	BLUE																					49				20		18	17	16		14	13	12													9	8	7	6			3		1	SALEABLE	NOT APPLICABLE	34576-7943	0	A	BLACK	48	47	46	45					40		38	37	36								34		32	31			29			25	24	23	22								49				20	19			16	15			12												10	9				5			2	1	SALEABLE	NOT APPLICABLE	34576-7953	0	G	BLUE					52	51	50				46	45									28	27	26					21		33	18	17									14	13	12									3			SALEABLE	NOT APPLICABLE	34576-7963	9	A	BLACK	48		46				43			39	38		36	35							34	33	32	31			29		27		25	24	23	22	21							49				20	19								11											10	9		7	6					1	SALEABLE	NOT APPLICABLE	34576-7973	0	A	BLACK	48	47	46	45	44	43			40		38	37	36								34		32	31			28	27		25	24	23	22								49				20	19			16	15			12												10	9				5			2	1	SALEABLE	NOT APPLICABLE	34576-7983	9	A	BLACK			32				29	28		26	25	38	23								49				20		18		16	15															10		8	7	6	5																																																																
SALEABLE	NOT APPLICABLE	34576-7913	9	A	BLACK	48		46				43			39	38		36	35							34	33	32	31			29		27		25	24	23	22	21							49				20	19								11											10	9		7	6					1	SALEABLE	NOT APPLICABLE	34576-7923	0	A	BLACK	48	47	46	45	44	43			40		38	37	36								34		32	31			29	28	27		25	24	23	22							49				20	19	18	17	16	15			12												10	9			6	5			2	1	SALEABLE	NOT APPLICABLE	34576-7933	0	C	BLUE																					49				20		18	17	16		14	13	12													9	8	7	6			3		1	SALEABLE	NOT APPLICABLE	34576-7943	0	A	BLACK	48	47	46	45					40		38	37	36								34		32	31			29			25	24	23	22								49				20	19			16	15			12												10	9				5			2	1	SALEABLE	NOT APPLICABLE	34576-7953	0	G	BLUE					52	51	50				46	45									28	27	26					21		33	18	17									14	13	12									3			SALEABLE	NOT APPLICABLE	34576-7963	9	A	BLACK	48		46				43			39	38		36	35							34	33	32	31			29		27		25	24	23	22	21							49				20	19								11											10	9		7	6					1	SALEABLE	NOT APPLICABLE	34576-7973	0	A	BLACK	48	47	46	45	44	43			40		38	37	36								34		32	31			28	27		25	24	23	22								49				20	19			16	15			12												10	9				5			2	1	SALEABLE	NOT APPLICABLE	34576-7983	9	A	BLACK			32				29	28		26	25	38	23								49				20		18		16	15															10		8	7	6	5																																																																																				
						34	33	32	31			29		27		25	24	23	22	21							49				20	19								11											10	9		7	6					1	SALEABLE	NOT APPLICABLE	34576-7923	0	A	BLACK	48	47	46	45	44	43			40		38	37	36								34		32	31			29	28	27		25	24	23	22							49				20	19	18	17	16	15			12												10	9			6	5			2	1	SALEABLE	NOT APPLICABLE	34576-7933	0	C	BLUE																					49				20		18	17	16		14	13	12													9	8	7	6			3		1	SALEABLE	NOT APPLICABLE	34576-7943	0	A	BLACK	48	47	46	45					40		38	37	36								34		32	31			29			25	24	23	22								49				20	19			16	15			12												10	9				5			2	1	SALEABLE	NOT APPLICABLE	34576-7953	0	G	BLUE					52	51	50				46	45									28	27	26					21		33	18	17									14	13	12									3			SALEABLE	NOT APPLICABLE	34576-7963	9	A	BLACK	48		46				43			39	38		36	35							34	33	32	31			29		27		25	24	23	22	21							49				20	19								11											10	9		7	6					1	SALEABLE	NOT APPLICABLE	34576-7973	0	A	BLACK	48	47	46	45	44	43			40		38	37	36								34		32	31			28	27		25	24	23	22								49				20	19			16	15			12												10	9				5			2	1	SALEABLE	NOT APPLICABLE	34576-7983	9	A	BLACK			32				29	28		26	25	38	23								49				20		18		16	15															10		8	7	6	5																																																																																																								
						49				20	19								11											10	9		7	6					1	SALEABLE	NOT APPLICABLE	34576-7923	0	A	BLACK	48	47	46	45	44	43			40		38	37	36								34		32	31			29	28	27		25	24	23	22							49				20	19	18	17	16	15			12												10	9			6	5			2	1	SALEABLE	NOT APPLICABLE	34576-7933	0	C	BLUE																					49				20		18	17	16		14	13	12													9	8	7	6			3		1	SALEABLE	NOT APPLICABLE	34576-7943	0	A	BLACK	48	47	46	45					40		38	37	36								34		32	31			29			25	24	23	22								49				20	19			16	15			12												10	9				5			2	1	SALEABLE	NOT APPLICABLE	34576-7953	0	G	BLUE					52	51	50				46	45									28	27	26					21		33	18	17									14	13	12									3			SALEABLE	NOT APPLICABLE	34576-7963	9	A	BLACK	48		46				43			39	38		36	35							34	33	32	31			29		27		25	24	23	22	21							49				20	19								11											10	9		7	6					1	SALEABLE	NOT APPLICABLE	34576-7973	0	A	BLACK	48	47	46	45	44	43			40		38	37	36								34		32	31			28	27		25	24	23	22								49				20	19			16	15			12												10	9				5			2	1	SALEABLE	NOT APPLICABLE	34576-7983	9	A	BLACK			32				29	28		26	25	38	23								49				20		18		16	15															10		8	7	6	5																																																																																																																													
										10	9		7	6					1	SALEABLE	NOT APPLICABLE	34576-7923	0	A	BLACK	48	47	46	45	44	43			40		38	37	36								34		32	31			29	28	27		25	24	23	22							49				20	19	18	17	16	15			12												10	9			6	5			2	1	SALEABLE	NOT APPLICABLE	34576-7933	0	C	BLUE																					49				20		18	17	16		14	13	12													9	8	7	6			3		1	SALEABLE	NOT APPLICABLE	34576-7943	0	A	BLACK	48	47	46	45					40		38	37	36								34		32	31			29			25	24	23	22								49				20	19			16	15			12												10	9				5			2	1	SALEABLE	NOT APPLICABLE	34576-7953	0	G	BLUE					52	51	50				46	45									28	27	26					21		33	18	17									14	13	12									3			SALEABLE	NOT APPLICABLE	34576-7963	9	A	BLACK	48		46				43			39	38		36	35							34	33	32	31			29		27		25	24	23	22	21							49				20	19								11											10	9		7	6					1	SALEABLE	NOT APPLICABLE	34576-7973	0	A	BLACK	48	47	46	45	44	43			40		38	37	36								34		32	31			28	27		25	24	23	22								49				20	19			16	15			12												10	9				5			2	1	SALEABLE	NOT APPLICABLE	34576-7983	9	A	BLACK			32				29	28		26	25	38	23								49				20		18		16	15															10		8	7	6	5																																																																																																																																																	
SALEABLE	NOT APPLICABLE	34576-7923	0	A	BLACK	48	47	46	45	44	43			40		38	37	36								34		32	31			29	28	27		25	24	23	22							49				20	19	18	17	16	15			12												10	9			6	5			2	1	SALEABLE	NOT APPLICABLE	34576-7933	0	C	BLUE																					49				20		18	17	16		14	13	12													9	8	7	6			3		1	SALEABLE	NOT APPLICABLE	34576-7943	0	A	BLACK	48	47	46	45					40		38	37	36								34		32	31			29			25	24	23	22								49				20	19			16	15			12												10	9				5			2	1	SALEABLE	NOT APPLICABLE	34576-7953	0	G	BLUE					52	51	50				46	45									28	27	26					21		33	18	17									14	13	12									3			SALEABLE	NOT APPLICABLE	34576-7963	9	A	BLACK	48		46				43			39	38		36	35							34	33	32	31			29		27		25	24	23	22	21							49				20	19								11											10	9		7	6					1	SALEABLE	NOT APPLICABLE	34576-7973	0	A	BLACK	48	47	46	45	44	43			40		38	37	36								34		32	31			28	27		25	24	23	22								49				20	19			16	15			12												10	9				5			2	1	SALEABLE	NOT APPLICABLE	34576-7983	9	A	BLACK			32				29	28		26	25	38	23								49				20		18		16	15															10		8	7	6	5																																																																																																																																																																					
						34		32	31			29	28	27		25	24	23	22							49				20	19	18	17	16	15			12												10	9			6	5			2	1	SALEABLE	NOT APPLICABLE	34576-7933	0	C	BLUE																					49				20		18	17	16		14	13	12													9	8	7	6			3		1	SALEABLE	NOT APPLICABLE	34576-7943	0	A	BLACK	48	47	46	45					40		38	37	36								34		32	31			29			25	24	23	22								49				20	19			16	15			12												10	9				5			2	1	SALEABLE	NOT APPLICABLE	34576-7953	0	G	BLUE					52	51	50				46	45									28	27	26					21		33	18	17									14	13	12									3			SALEABLE	NOT APPLICABLE	34576-7963	9	A	BLACK	48		46				43			39	38		36	35							34	33	32	31			29		27		25	24	23	22	21							49				20	19								11											10	9		7	6					1	SALEABLE	NOT APPLICABLE	34576-7973	0	A	BLACK	48	47	46	45	44	43			40		38	37	36								34		32	31			28	27		25	24	23	22								49				20	19			16	15			12												10	9				5			2	1	SALEABLE	NOT APPLICABLE	34576-7983	9	A	BLACK			32				29	28		26	25	38	23								49				20		18		16	15															10		8	7	6	5																																																																																																																																																																																									
						49				20	19	18	17	16	15			12												10	9			6	5			2	1	SALEABLE	NOT APPLICABLE	34576-7933	0	C	BLUE																					49				20		18	17	16		14	13	12													9	8	7	6			3		1	SALEABLE	NOT APPLICABLE	34576-7943	0	A	BLACK	48	47	46	45					40		38	37	36								34		32	31			29			25	24	23	22								49				20	19			16	15			12												10	9				5			2	1	SALEABLE	NOT APPLICABLE	34576-7953	0	G	BLUE					52	51	50				46	45									28	27	26					21		33	18	17									14	13	12									3			SALEABLE	NOT APPLICABLE	34576-7963	9	A	BLACK	48		46				43			39	38		36	35							34	33	32	31			29		27		25	24	23	22	21							49				20	19								11											10	9		7	6					1	SALEABLE	NOT APPLICABLE	34576-7973	0	A	BLACK	48	47	46	45	44	43			40		38	37	36								34		32	31			28	27		25	24	23	22								49				20	19			16	15			12												10	9				5			2	1	SALEABLE	NOT APPLICABLE	34576-7983	9	A	BLACK			32				29	28		26	25	38	23								49				20		18		16	15															10		8	7	6	5																																																																																																																																																																																																													
										10	9			6	5			2	1	SALEABLE	NOT APPLICABLE	34576-7933	0	C	BLUE																					49				20		18	17	16		14	13	12													9	8	7	6			3		1	SALEABLE	NOT APPLICABLE	34576-7943	0	A	BLACK	48	47	46	45					40		38	37	36								34		32	31			29			25	24	23	22								49				20	19			16	15			12												10	9				5			2	1	SALEABLE	NOT APPLICABLE	34576-7953	0	G	BLUE					52	51	50				46	45									28	27	26					21		33	18	17									14	13	12									3			SALEABLE	NOT APPLICABLE	34576-7963	9	A	BLACK	48		46				43			39	38		36	35							34	33	32	31			29		27		25	24	23	22	21							49				20	19								11											10	9		7	6					1	SALEABLE	NOT APPLICABLE	34576-7973	0	A	BLACK	48	47	46	45	44	43			40		38	37	36								34		32	31			28	27		25	24	23	22								49				20	19			16	15			12												10	9				5			2	1	SALEABLE	NOT APPLICABLE	34576-7983	9	A	BLACK			32				29	28		26	25	38	23								49				20		18		16	15															10		8	7	6	5																																																																																																																																																																																																																																	
SALEABLE	NOT APPLICABLE	34576-7933	0	C	BLUE																					49				20		18	17	16		14	13	12													9	8	7	6			3		1	SALEABLE	NOT APPLICABLE	34576-7943	0	A	BLACK	48	47	46	45					40		38	37	36								34		32	31			29			25	24	23	22								49				20	19			16	15			12												10	9				5			2	1	SALEABLE	NOT APPLICABLE	34576-7953	0	G	BLUE					52	51	50				46	45									28	27	26					21		33	18	17									14	13	12									3			SALEABLE	NOT APPLICABLE	34576-7963	9	A	BLACK	48		46				43			39	38		36	35							34	33	32	31			29		27		25	24	23	22	21							49				20	19								11											10	9		7	6					1	SALEABLE	NOT APPLICABLE	34576-7973	0	A	BLACK	48	47	46	45	44	43			40		38	37	36								34		32	31			28	27		25	24	23	22								49				20	19			16	15			12												10	9				5			2	1	SALEABLE	NOT APPLICABLE	34576-7983	9	A	BLACK			32				29	28		26	25	38	23								49				20		18		16	15															10		8	7	6	5																																																																																																																																																																																																																																																					
						49				20		18	17	16		14	13	12													9	8	7	6			3		1	SALEABLE	NOT APPLICABLE	34576-7943	0	A	BLACK	48	47	46	45					40		38	37	36								34		32	31			29			25	24	23	22								49				20	19			16	15			12												10	9				5			2	1	SALEABLE	NOT APPLICABLE	34576-7953	0	G	BLUE					52	51	50				46	45									28	27	26					21		33	18	17									14	13	12									3			SALEABLE	NOT APPLICABLE	34576-7963	9	A	BLACK	48		46				43			39	38		36	35							34	33	32	31			29		27		25	24	23	22	21							49				20	19								11											10	9		7	6					1	SALEABLE	NOT APPLICABLE	34576-7973	0	A	BLACK	48	47	46	45	44	43			40		38	37	36								34		32	31			28	27		25	24	23	22								49				20	19			16	15			12												10	9				5			2	1	SALEABLE	NOT APPLICABLE	34576-7983	9	A	BLACK			32				29	28		26	25	38	23								49				20		18		16	15															10		8	7	6	5																																																																																																																																																																																																																																																																									
											9	8	7	6			3		1	SALEABLE	NOT APPLICABLE	34576-7943	0	A	BLACK	48	47	46	45					40		38	37	36								34		32	31			29			25	24	23	22								49				20	19			16	15			12												10	9				5			2	1	SALEABLE	NOT APPLICABLE	34576-7953	0	G	BLUE					52	51	50				46	45									28	27	26					21		33	18	17									14	13	12									3			SALEABLE	NOT APPLICABLE	34576-7963	9	A	BLACK	48		46				43			39	38		36	35							34	33	32	31			29		27		25	24	23	22	21							49				20	19								11											10	9		7	6					1	SALEABLE	NOT APPLICABLE	34576-7973	0	A	BLACK	48	47	46	45	44	43			40		38	37	36								34		32	31			28	27		25	24	23	22								49				20	19			16	15			12												10	9				5			2	1	SALEABLE	NOT APPLICABLE	34576-7983	9	A	BLACK			32				29	28		26	25	38	23								49				20		18		16	15															10		8	7	6	5																																																																																																																																																																																																																																																																																													
SALEABLE	NOT APPLICABLE	34576-7943	0	A	BLACK	48	47	46	45					40		38	37	36								34		32	31			29			25	24	23	22								49				20	19			16	15			12												10	9				5			2	1	SALEABLE	NOT APPLICABLE	34576-7953	0	G	BLUE					52	51	50				46	45									28	27	26					21		33	18	17									14	13	12									3			SALEABLE	NOT APPLICABLE	34576-7963	9	A	BLACK	48		46				43			39	38		36	35							34	33	32	31			29		27		25	24	23	22	21							49				20	19								11											10	9		7	6					1	SALEABLE	NOT APPLICABLE	34576-7973	0	A	BLACK	48	47	46	45	44	43			40		38	37	36								34		32	31			28	27		25	24	23	22								49				20	19			16	15			12												10	9				5			2	1	SALEABLE	NOT APPLICABLE	34576-7983	9	A	BLACK			32				29	28		26	25	38	23								49				20		18		16	15															10		8	7	6	5																																																																																																																																																																																																																																																																																																																	
						34		32	31			29			25	24	23	22								49				20	19			16	15			12												10	9				5			2	1	SALEABLE	NOT APPLICABLE	34576-7953	0	G	BLUE					52	51	50				46	45									28	27	26					21		33	18	17									14	13	12									3			SALEABLE	NOT APPLICABLE	34576-7963	9	A	BLACK	48		46				43			39	38		36	35							34	33	32	31			29		27		25	24	23	22	21							49				20	19								11											10	9		7	6					1	SALEABLE	NOT APPLICABLE	34576-7973	0	A	BLACK	48	47	46	45	44	43			40		38	37	36								34		32	31			28	27		25	24	23	22								49				20	19			16	15			12												10	9				5			2	1	SALEABLE	NOT APPLICABLE	34576-7983	9	A	BLACK			32				29	28		26	25	38	23								49				20		18		16	15															10		8	7	6	5																																																																																																																																																																																																																																																																																																																																					
						49				20	19			16	15			12												10	9				5			2	1	SALEABLE	NOT APPLICABLE	34576-7953	0	G	BLUE					52	51	50				46	45									28	27	26					21		33	18	17									14	13	12									3			SALEABLE	NOT APPLICABLE	34576-7963	9	A	BLACK	48		46				43			39	38		36	35							34	33	32	31			29		27		25	24	23	22	21							49				20	19								11											10	9		7	6					1	SALEABLE	NOT APPLICABLE	34576-7973	0	A	BLACK	48	47	46	45	44	43			40		38	37	36								34		32	31			28	27		25	24	23	22								49				20	19			16	15			12												10	9				5			2	1	SALEABLE	NOT APPLICABLE	34576-7983	9	A	BLACK			32				29	28		26	25	38	23								49				20		18		16	15															10		8	7	6	5																																																																																																																																																																																																																																																																																																																																																									
										10	9				5			2	1	SALEABLE	NOT APPLICABLE	34576-7953	0	G	BLUE					52	51	50				46	45									28	27	26					21		33	18	17									14	13	12									3			SALEABLE	NOT APPLICABLE	34576-7963	9	A	BLACK	48		46				43			39	38		36	35							34	33	32	31			29		27		25	24	23	22	21							49				20	19								11											10	9		7	6					1	SALEABLE	NOT APPLICABLE	34576-7973	0	A	BLACK	48	47	46	45	44	43			40		38	37	36								34		32	31			28	27		25	24	23	22								49				20	19			16	15			12												10	9				5			2	1	SALEABLE	NOT APPLICABLE	34576-7983	9	A	BLACK			32				29	28		26	25	38	23								49				20		18		16	15															10		8	7	6	5																																																																																																																																																																																																																																																																																																																																																																													
SALEABLE	NOT APPLICABLE	34576-7953	0	G	BLUE					52	51	50				46	45									28	27	26					21		33	18	17									14	13	12									3			SALEABLE	NOT APPLICABLE	34576-7963	9	A	BLACK	48		46				43			39	38		36	35							34	33	32	31			29		27		25	24	23	22	21							49				20	19								11											10	9		7	6					1	SALEABLE	NOT APPLICABLE	34576-7973	0	A	BLACK	48	47	46	45	44	43			40		38	37	36								34		32	31			28	27		25	24	23	22								49				20	19			16	15			12												10	9				5			2	1	SALEABLE	NOT APPLICABLE	34576-7983	9	A	BLACK			32				29	28		26	25	38	23								49				20		18		16	15															10		8	7	6	5																																																																																																																																																																																																																																																																																																																																																																																																	
						28	27	26					21		33	18	17									14	13	12									3			SALEABLE	NOT APPLICABLE	34576-7963	9	A	BLACK	48		46				43			39	38		36	35							34	33	32	31			29		27		25	24	23	22	21							49				20	19								11											10	9		7	6					1	SALEABLE	NOT APPLICABLE	34576-7973	0	A	BLACK	48	47	46	45	44	43			40		38	37	36								34		32	31			28	27		25	24	23	22								49				20	19			16	15			12												10	9				5			2	1	SALEABLE	NOT APPLICABLE	34576-7983	9	A	BLACK			32				29	28		26	25	38	23								49				20		18		16	15															10		8	7	6	5																																																																																																																																																																																																																																																																																																																																																																																																																					
						14	13	12									3			SALEABLE	NOT APPLICABLE	34576-7963	9	A	BLACK	48		46				43			39	38		36	35							34	33	32	31			29		27		25	24	23	22	21							49				20	19								11											10	9		7	6					1	SALEABLE	NOT APPLICABLE	34576-7973	0	A	BLACK	48	47	46	45	44	43			40		38	37	36								34		32	31			28	27		25	24	23	22								49				20	19			16	15			12												10	9				5			2	1	SALEABLE	NOT APPLICABLE	34576-7983	9	A	BLACK			32				29	28		26	25	38	23								49				20		18		16	15															10		8	7	6	5																																																																																																																																																																																																																																																																																																																																																																																																																																									
SALEABLE	NOT APPLICABLE	34576-7963	9	A	BLACK	48		46				43			39	38		36	35							34	33	32	31			29		27		25	24	23	22	21							49				20	19								11											10	9		7	6					1	SALEABLE	NOT APPLICABLE	34576-7973	0	A	BLACK	48	47	46	45	44	43			40		38	37	36								34		32	31			28	27		25	24	23	22								49				20	19			16	15			12												10	9				5			2	1	SALEABLE	NOT APPLICABLE	34576-7983	9	A	BLACK			32				29	28		26	25	38	23								49				20		18		16	15															10		8	7	6	5																																																																																																																																																																																																																																																																																																																																																																																																																																																													
						34	33	32	31			29		27		25	24	23	22	21							49				20	19								11											10	9		7	6					1	SALEABLE	NOT APPLICABLE	34576-7973	0	A	BLACK	48	47	46	45	44	43			40		38	37	36								34		32	31			28	27		25	24	23	22								49				20	19			16	15			12												10	9				5			2	1	SALEABLE	NOT APPLICABLE	34576-7983	9	A	BLACK			32				29	28		26	25	38	23								49				20		18		16	15															10		8	7	6	5																																																																																																																																																																																																																																																																																																																																																																																																																																																																																	
						49				20	19								11											10	9		7	6					1	SALEABLE	NOT APPLICABLE	34576-7973	0	A	BLACK	48	47	46	45	44	43			40		38	37	36								34		32	31			28	27		25	24	23	22								49				20	19			16	15			12												10	9				5			2	1	SALEABLE	NOT APPLICABLE	34576-7983	9	A	BLACK			32				29	28		26	25	38	23								49				20		18		16	15															10		8	7	6	5																																																																																																																																																																																																																																																																																																																																																																																																																																																																																																						
										10	9		7	6					1	SALEABLE	NOT APPLICABLE	34576-7973	0	A	BLACK	48	47	46	45	44	43			40		38	37	36								34		32	31			28	27		25	24	23	22								49				20	19			16	15			12												10	9				5			2	1	SALEABLE	NOT APPLICABLE	34576-7983	9	A	BLACK			32				29	28		26	25	38	23								49				20		18		16	15															10		8	7	6	5																																																																																																																																																																																																																																																																																																																																																																																																																																																																																																																										
SALEABLE	NOT APPLICABLE	34576-7973	0	A	BLACK	48	47	46	45	44	43			40		38	37	36								34		32	31			28	27		25	24	23	22								49				20	19			16	15			12												10	9				5			2	1	SALEABLE	NOT APPLICABLE	34576-7983	9	A	BLACK			32				29	28		26	25	38	23								49				20		18		16	15															10		8	7	6	5																																																																																																																																																																																																																																																																																																																																																																																																																																																																																																																																														
						34		32	31			28	27		25	24	23	22								49				20	19			16	15			12												10	9				5			2	1	SALEABLE	NOT APPLICABLE	34576-7983	9	A	BLACK			32				29	28		26	25	38	23								49				20		18		16	15															10		8	7	6	5																																																																																																																																																																																																																																																																																																																																																																																																																																																																																																																																																																		
						49				20	19			16	15			12												10	9				5			2	1	SALEABLE	NOT APPLICABLE	34576-7983	9	A	BLACK			32				29	28		26	25	38	23								49				20		18		16	15															10		8	7	6	5																																																																																																																																																																																																																																																																																																																																																																																																																																																																																																																																																																																						
										10	9				5			2	1	SALEABLE	NOT APPLICABLE	34576-7983	9	A	BLACK			32				29	28		26	25	38	23								49				20		18		16	15															10		8	7	6	5																																																																																																																																																																																																																																																																																																																																																																																																																																																																																																																																																																																																										
SALEABLE	NOT APPLICABLE	34576-7983	9	A	BLACK			32				29	28		26	25	38	23								49				20		18		16	15															10		8	7	6	5																																																																																																																																																																																																																																																																																																																																																																																																																																																																																																																																																																																																																														
						49				20		18		16	15															10		8	7	6	5																																																																																																																																																																																																																																																																																																																																																																																																																																																																																																																																																																																																																																																		
										10		8	7	6	5																																																																																																																																																																																																																																																																																																																																																																																																																																																																																																																																																																																																																																																																						



MX123 18/28/42/49/56-WAY RECEPTACLE ASSY SEALED PIN OUT SHEET

STATUS	GM PART #	HRNS CONN ASSY			TPA GROMMET CAP														
		MATERIAL/PART	WIRE DRESS OPTION	KEY OPTION ▽ Fp	COLOR OPTION ▽ Fp	NUMBERS INDICATE CAVITIES OPEN FOR CIRCUITS ▽ Fp													
		NUMBER																	
SALEABLE	NOT APPLICABLE	34576-7993	9	C	BLUE		47		45	44		42		40	39	38	37	36	
						34		32		30		28				24	23		21
						49					9	7		15	14	13	12	11	
SALEABLE	NOT APPLICABLE	34576-8003	0	A	BLACK	48	47	46	45	44	43			40		38	37	36	
						34		32	31		29	28	27		25	24	23	22	
						49				20	19			16				12	
SALEABLE	NOT APPLICABLE	34576-8013	0	H	ST GR Y			54	53	52	51					46	45	44	43
								40	39	38	37	36	35	34	33				
								26	25										
SALEABLE	NOT APPLICABLE	34576-8023	9	A	BLACK	14	13	12	11			8	7	6	5			2	1
						48	47	46	45					40			37	36	
						34		32	31		29				25	24	23	22	
SALEABLE	NOT APPLICABLE	34576-8033	9	A	BLACK	49				20	19	18		16				12	
										10	9				5			2	1
							33	32			29	28		26	25		23		
SALEABLE	NOT APPLICABLE	34576-8043	9	C	BLUE	49				20		18	17	16	15				
										10		8	7	6	5	4		2	
							47		45	44				40	39	38	37	36	
SALEABLE	NOT APPLICABLE	34576-8053	0	A	BLACK	34		32		30		28				24	23		21
						49						18	17		15	14	13	12	11
										9		7		5		3		1	
SALEABLE	NOT APPLICABLE	34576-8063	9	A	BLACK	48	47	46	45	44	43			40		38	37	36	
						34		32	31		29	28	27		25	24	23	22	
						49				20	19			16				12	
SALEABLE	NOT APPLICABLE	34576-8073	0	C	BLUE														
						48	47	46	45	44			41	40	39	38	37	36	
						34	33	32		30		28				24	23	22	21
SALEABLE	NOT APPLICABLE	34576-8073	0	C	BLUE	49				20		18	17	16		14	13	12	
										9	8	7	6			3		1	



MX123 18/28/42/49/56-WAY RECEPTACLE ASSY SEALED PIN OUT SHEET

STATUS	GM PART #	HRNS CONN ASSY			TPA GROMMET CAP																
		MATERIAL/PART NUMBER	WIRE DRESS OPTION	KEY OPTION ▽ Fp	COLOR OPTION ▽ Fp	NUMBERS INDICATE CAVITIES OPEN FOR CIRCUITS ▽ Fp															
SALEABLE	NOT APPLICABLE	34576-8083	0	H	ST GR	56	55	54	53	52	51					46	45	44	43		
						42	41	40	39	38	37	36	35	34	33						
						28	27	26	25	24	23	22	21	20	19						
						14	13	12	11			8	7	6	5					2	1
SALEABLE	NOT APPLICABLE	34576-8093	0	H	ST GR			54	53	52	51					46	45	44	43		
								40	39	38	37	36	35	34	33						
						28	27	26	25	24	23										
						14	13	12	11			8	7	6	5					2	1
SALEABLE	NOT APPLICABLE	34576-8103	0	H	ST GR			54	53	52	51										
								40	39	38	37	36	35	34	33						
						28	27	26	25	24	23										
						14	13	12	11											2	1
SALEABLE	NOT APPLICABLE	34576-8113	0	A	BLACK	48	47	46	45	44	43			40		38	37	36			
						34		32	31			29	28	27		25	24	23	22		
						49						20	19	18	17	16	15			12	
												10	9				5			2	1
SALEABLE	NOT APPLICABLE	34576-8123	0	A	BLACK	48	47	46	45	44	43			40		38	37	36			
						34		32	31			28	27		25	24	23	22			
						49						20	19		17	16	15			12	
												10	9				5			2	1
SALEABLE	NOT APPLICABLE	34576-8133	0	A	BLACK	48		46		44	43	42		40	39	38					
						34	33	32	31			29	28		26	25	24	23		21	
						49												14			11
														8	7					3	
SALEABLE	NOT APPLICABLE	34576-8143	0	G	BLUE	56	55	54	53	52	51	50	49	48	47	46	45	44	43		
								40				36	35				31				
							27		25	24		22	21		19	18					
							13	12		10	9	8	7	6				3			
SALEABLE	NOT APPLICABLE	34576-9133	9	A	BLACK	48	47	46	45	44	43			40		38	37	36			
						34		32	31			29	28	27		25	24	23	22		
						49						20	19	18	17	16				12	
												10	9				5			2	1
SALEABLE	NOT APPLICABLE	34576-9143	9	C	BLUE		47		45	44				40	39	38	37	36			
						34		32		30				26	25	24	23		21		
						49								18	17		15	14	13	12	
												10	9		7	6	5		3		1



MX123 18/28/42/49/56-WAY RECEPTACLE ASSY SEALED PIN OUT SHEET

STATUS	GM PART #	HRNS CONN ASSY			TPA GROMMET CAP																	
		MATERIAL/PART	WIRE DRESS OPTION	KEY OPTION ▽ Fp	COLOR OPTION ▽ Fp	NUMBERS INDICATE CAVITIES OPEN FOR CIRCUITS ▽ Fp																
		NUMBER																				
SALEABLE	NOT APPLICABLE	34576-9153	9	A	BLACK					44	43		41					37	36			
						34	33	32													22	
						49						18	17	16	15							
										8	7	6	5									

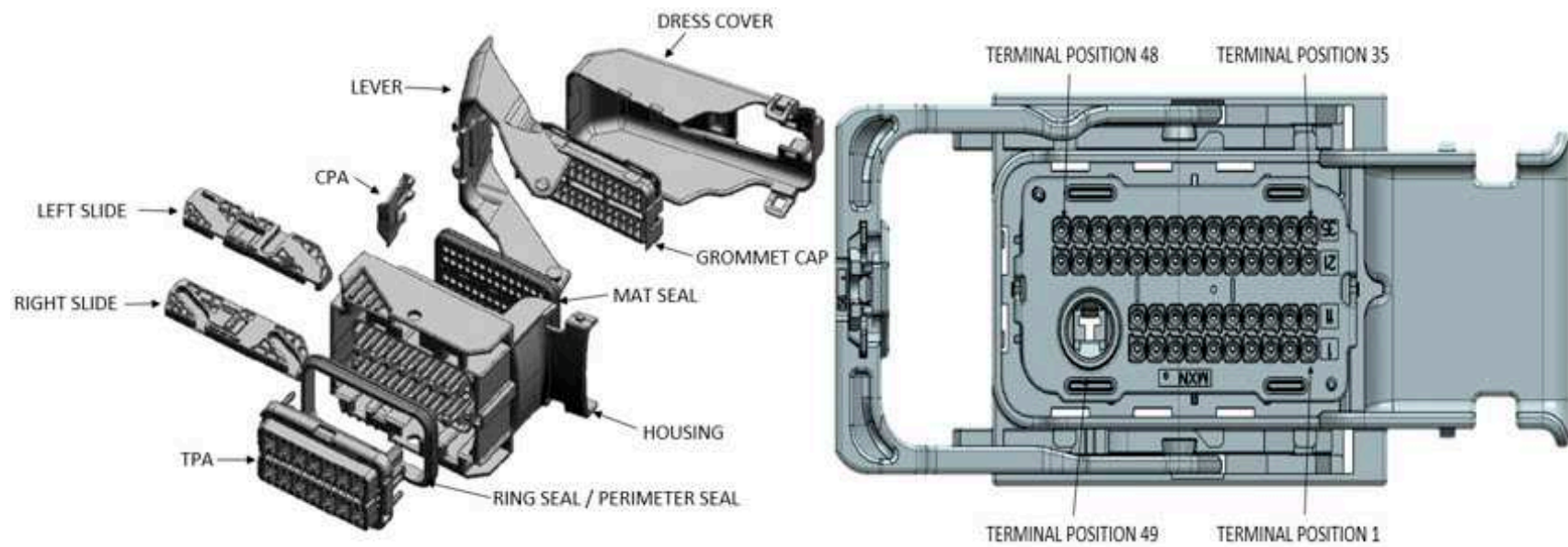

G-CAP-0-0	GROMMET CAP OPTION 0 All OPEN	BLACK	SPS/PA, G.F 30%
G-CAP-9-P	GROMMET CAP OPTION 9 PLUGGED	BLACK	SPS/PA, G.F 30%
G-CAP-9-O	GROMMET CAP OPTION 9 All OPEN	BLACK	SPS/PA, G.F 30%
C-HSG-A0	CONNECTOR HOUSING KEY A - WDC OPT 0	BLACK	SPS/PA, G.F 30%
C-HSG-B0	CONNECTOR HOUSING KEY B - WDC OPT 0	BLACK	SPS/PA, G.F 30%
C-HSG-C0	CONNECTOR HOUSING KEY C - WDC OPT 0	BLACK	SPS/PA, G.F 30%
C-HSG-D0	CONNECTOR HOUSING KEY D - WDC OPT 0	BLACK	SPS/PA, G.F 30%
C-HSG-E0	CONNECTOR HOUSING KEY E - WDC OPT 0	BLACK	SPS/PA, G.F 30%
C-HSG-F0	CONNECTOR HOUSING KEY F - WDC OPT 0	BLACK	SPS/PA, G.F 30%
C-HSG-A9	CONNECTOR HOUSING KEY A - WDC OPT 9	BLACK	SPS/PA, G.F 30%
C-HSG-B9	CONNECTOR HOUSING KEY B - WDC OPT 9	BLACK	SPS/PA, G.F 30%
C-HSG-C9	CONNECTOR HOUSING KEY C - WDC OPT 9	BLACK	SPS/PA, G.F 30%
C-HSG-D9	CONNECTOR HOUSING KEY D - WDC OPT 9	BLACK	SPS/PA, G.F 30%
C-HSG-E9	CONNECTOR HOUSING KEY E - WDC OPT 9	BLACK	SPS/PA, G.F 30%
C-HSG-F9	CONNECTOR HOUSING KEY F - WDC OPT 9	BLACK	SPS/PA, G.F 30%
TPA-A0	TERMINAL POSITION ASSURANCE (TPA) OPTION 0	BLACK	SPS/PA, G.F 30%
TPA-B0	TERMINAL POSITION ASSURANCE (TPA) OPTION 0	STONE GRAY	SPS/PA, G.F 30%
TPA-C0	TERMINAL POSITION ASSURANCE (TPA) OPTION 0	BLUE	SPS/PA, G.F 30%
TPA-D0	TERMINAL POSITION ASSURANCE (TPA) OPTION 0	BROWN	SPS/PA, G.F 30%
TPA-E0	TERMINAL POSITION ASSURANCE (TPA) OPTION 0	GREEN	SPS/PA, G.F 30%
TPA-F0	TERMINAL POSITION ASSURANCE (TPA) OPTION 0	NATURAL	SPS/PA, G.F 30%
TPA-A9	TERMINAL POSITION ASSURANCE (TPA) OPTION 9	BLACK	SPS/PA, G.F 30%
TPA-B9	TERMINAL POSITION ASSURANCE (TPA) OPTION 9	STONE GRAY	SPS/PA, G.F 30%
TPA-C9	TERMINAL POSITION ASSURANCE (TPA) OPTION 9	BLUE	SPS/PA, G.F 30%
TPA-D9	TERMINAL POSITION ASSURANCE (TPA) OPTION 9	BROWN	SPS/PA, G.F 30%
TPA-E9	TERMINAL POSITION ASSURANCE (TPA) OPTION 9	GREEN	SPS/PA, G.F 30%
TPA-F9	TERMINAL POSITION ASSURANCE (TPA) OPTION 9	NATURAL	SPS/PA, G.F 30%
MAL	MATE ASSIST LEVER	BLACK	SPS/NYLON GF30
RS	SLIDE - RIGHT	BLACK	PPE/PA, G.F. 30%
LS	SLIDE - LEFT	BLACK	PPE/PA, G.F. 30%
CVR BLACK	DRESS COVER BLACK	BLACK	PBT, G.F. 30%
CVR GRAY	DRESS COVER GRAY	GRAY	PBT, G.F. 30%
CVR BLUE	DRESS COVER BLUE	BLUE	PBT, G.F. 30%
CVR BROWN	DRESS COVER BROWN	BROWN	PBT, G.F. 30%
CVR GREEN	DRESS COVER GREEN	GREEN	PBT, G.F. 30%
CVR NATURAL	DRESS COVER NATURAL	NATURAL	PBT, G.F. 30%
CVR YELLOW	DRESS COVER YELLOW	YELLOW	PBT, G.F. 30%
CPA	CONNECTOR POSITION ASSURANCE (CPA)	RED	PPE/PA 10% GF
MSEAL	MAT SEAL	RUST RED	INHERENTLY LUBRICATED SILICONE RUBBER
RSEAL	RING SEAL	RUST RED	INHERENTLY LUBRICATED SILICONE RUBBER

FOR ADDITIONAL INFORMATION SEE SD-34576-001

ASSEMBLY DESCRIPTION	ASSEMBLY PART NUMBER	CONNECTOR HOUSING	GROMMET CAP	TPA	RIGHT SLIDE	LEFT SLIDE	MATE ASSIST LEVER	CPA	MAT SEAL	RING SEAL	BLOCKED TERMINALS												STATUS	COMMENTS	INTEGRAL COMPONENTS SOLD SEPARATELY DRESS COVER			
											CAVITY WITH A NUMBER INDICATES BLOCKED TERMINAL POSITION CAVITY WITHOUT A NUMBER INDICATES OPEN TERMINAL POSITION																	
MX123 CONN ASSY 49 CKT BLK OPT0 KEY A/49	345760103	C-HSG-A0	G-CAP-0-P	TPA-A0	RS	LS	MAL	CPA	MSEAL	RSEAL	-	-	-	-	-	-	-	-	-	-	-	-	-	-	-	SALEABLE		345750003
MX123 CONN ASSY 49 CKT BLU OPT0 KEY C/49	345760303	C-HSG-C0	G-CAP-0-P	TPA-C0	RS	LS	MAL	CPA	MSEAL	RSEAL	-	-	-	-	-	-	-	-	-	-	-	-	-	-	-	SALEABLE		345750003
MX123 CONN ASSY 49 CKT BLK OPT9 KEY A/49	345761303	C-HSG-A9	G-CAP-9-P	TPA-A9	RS	LS	MAL	CPA	MSEAL	RSEAL	-	-	-	-	-	-	-	-	-	-	-	-	-	-	-	SALEABLE		345750003
MX123 CONN ASSY 49 CKT BLU OPT9 KEY C/49	345761503	C-HSG-C9	G-CAP-9-P	TPA-C9	RS	LS	MAL	CPA	MSEAL	RSEAL	-	-	-	-	-	-	-	-	-	-	-	-	-	-	-	SALEABLE		345750003

	NUMBER				SLIDE	SLIDE	LEVER		SEAL	SEAL	CAVITY WITH A NUMBER INDICATES BLOCKED TERMINAL POSITION CAVITY WITHOUT A NUMBER INDICATES OPEN TERMINAL POSITION															DRESS COVER			
											-	47	-	45	-	-	42	41	-	-	-	37	36				-		
MX123 CONN ASSY 49 CKT BLK OPT0 KEY A/24	345767553	C-HSG-A0	G-CAP-0-P	TPA-A0	RS	LS	MAL	CPA	MSEAL	RSEAL															SALEABLE		345750003		
MX123 CONN ASSY 49 CKT BLU OPT0 KEY C/35	345767563	C-HSG-C0	G-CAP-0-P	TPA-C0	RS	LS	MAL	CPA	MSEAL	RSEAL					43	42	-	-	-	-	-	-	-	35	SALEABLE		345750003		
															31	-	29	28	27	26	25	-	-	22	-				
																20	19	-	-	-	-	-	-	11					
																	10	9	-	-	6	5	4	-	2	-			
MX123 CONN ASSY 49 CKT BLU OPT9 KEY C/34	345767613	C-HSG-C9	G-CAP-9-P	TPA-C9	RS	LS	MAL	CPA	MSEAL	RSEAL															SALEABLE		345750003		
MX123 CONN ASSY 49 CKT BLK OPT9 KEY A/26	345767623	C-HSG-A9	G-CAP-9-P	TPA-A9	RS	LS	MAL	CPA	MSEAL	RSEAL															SALEABLE		345750003		
MX123 CONN ASSY 49 CKT BLK OPT0 KEY A/35	345767633	C-HSG-A0	G-CAP-0-P	TPA-A0	RS	LS	MAL	CPA	MSEAL	RSEAL															SALEABLE		345750003		
MX123 CONN ASSY 49 CKT BLU OPT0 KEY C/38	345767653	C-HSG-C0	G-CAP-0-P	TPA-C0	RS	LS	MAL	CPA	MSEAL	RSEAL					44	43	42	41	-	39	-	-	-	35	SALEABLE		345750003		
															33	-	-	30	-	28	27	26	-	-	21				
																					15	14	13	-	11				
																						8	7	6	-	-			
MX123 CONN ASSY 49 CKT BLK OPT9 KEY A/28	345767663	C-HSG-A9	G-CAP-9-P	TPA-A9	RS	LS	MAL	CPA	MSEAL	RSEAL															SALEABLE		345750003		
MX123 CONN ASSY 49 CKT BLU OPT0 KEY C/36	345767673	C-HSG-C0	G-CAP-0-P	TPA-C0	RS	LS	MAL	CPA	MSEAL	RSEAL															SALEABLE		345750003		
MX123 CONN ASSY 49 CKT BLK OPT0 KEY A/28	345767683	C-HSG-A0	G-CAP-0-P	TPA-A0	RS	LS	MAL	CPA	MSEAL	RSEAL															SALEABLE		345750003		
MX123 CONN ASSY 49 CKT BLU OPT9 KEY C/35	345767723	C-HSG-C9	G-CAP-9-P	TPA-C9	RS	LS	MAL	CPA	MSEAL	RSEAL															SALEABLE		345750003		
MX123 CONN ASSY 49 CKT BLK OPT0 KEY A/24	345767733	C-HSG-A0	G-CAP-0-P	TPA-A0	RS	LS	MAL	CPA	MSEAL	RSEAL															SALEABLE		345750003		
MX123 CONN ASSY 49 CKT BLU OPT0 KEY C/12	345767743	C-HSG-C0	G-CAP-0-P	TPA-C0	RS	LS	MAL	CPA	MSEAL	RSEAL															SALEABLE		345750003		

PART NUMBER	NUMBER	C-HSG	G-CAP	TPA	RS	LS	MAL	CPA	MSEAL	RSEAL	CAVITY WITH A NUMBER INDICATES BLOCKED TERMINAL POSITION CAVITY WITHOUT A NUMBER INDICATES OPEN TERMINAL POSITION																SALEABLE	DRESS COVER																																																																																																																																																																																																																																																																																																																																																																																																																																																																																																																																										
											48	47	46	45	-	-	-	-	40	-	38	37	36	-	34	-			32	31	-	29	-	-	-	25	24	23	22	-	20	19	-	-	16	15	-	-	12	-	10	9	-	-	-	5	-	-	2	1																																																																																																																																																																																																																																																																																																																																																																																																																																																																																																										
MX123 CONN ASSY 49 CKT BLK OPT9 KEY A/23	345767763	C-HSG-A9	G-CAP-9-P	TPA-A9	RS	LS	MAL	CPA	MSEAL	RSEAL	-	-	-	-	-	-	42	41	-	39	-	-	-	35	-	33	-	-	30	-	-	-	26	-	-	-	21	-	-	-	18	17	-	-	14	13	-	11	-	-	8	7	6	-	4	3	-	-	-	-	-	-	43	42	-	-	-	-	-	35	-	-	-	31	-	29	28	-	26	25	-	-	22	-	20	19	-	-	16	-	-	-	-	11	-	-	-	-	-	-	-	4	-	-	-	-	-	-	-	-	44	43	42	41	-	39	-	-	-	35	-	33	-	-	30	29	28	27	26	-	-	-	21	-	-	-	-	-	-	-	14	13	-	11	-	-	8	7	6	-	4	3	-	-	-	-	-	-	43	42	-	-	-	-	-	35	-	-	-	31	-	29	28	-	26	25	-	-	22	-	20	19	-	-	16	-	-	-	-	11	-	-	-	-	-	-	-	6	-	4	-	-	-	-	-	-	-	44	43	42	41	-	39	-	-	-	35	-	33	-	-	30	-	28	27	26	-	-	-	21	-	-	-	-	-	-	18	-	-	15	14	13	-	11	-	-	8	7	6	-	4	3	-	1	-	-	46	-	-	43	42	-	-	-	-	-	-	-	33	-	31	-	29	-	27	26	25	-	23	22	-	20	19	-	-	16	-	-	-	-	-	10	-	8	-	-	-	4	-	2	-	-	-	-	-	-	-	42	41	-	39	-	-	-	35	-	33	-	-	30	29	-	-	26	-	-	-	21	-	-	-	-	-	-	-	-	14	13	-	11	-	-	8	7	-	-	4	3	-	-	-	-	-	-	-	43	-	-	-	-	-	-	-	-	-	-	31	-	-	-	-	26	25	-	-	22	-	-	19	-	-	-	-	-	-	-	11	-	-	-	-	-	-	-	-	-	4	-	2	-	-	47	-	45	44	-	42	41	40	-	-	37	-	-	-	-	32	-	30	-	28	-	26	-	-	-	22	-	-	-	-	-	-	-	18	17	16	15	14	13	12	-	-	-	8	-	-	5	4	3	2	-	-	-	-	-	-	-	42	-	-	-	-	-	-	35	-	-	-	31	-	29	28	-	26	25	-	-	22	-	20	19	-	-	16	-	-	-	-	11	10	-	-	-	-	-	4	-	2	-	-	-	-	-	-	-	42	41	-	39	38	-	-	35	-	33	-	-	30	-	28	-	26	-	-	-	21	-	-	-	-	-	-	17	-	15	14	13	-	11	-	-	8	7	-	-	4	3	-	-

NUMBER	C-HSG	G-CAP	TPA	RS	LS	MAL	CPA	MSEAL	RSEAL	CAVITY WITH A NUMBER INDICATES BLOCKED TERMINAL POSITION CAVITY WITHOUT A NUMBER INDICATES OPEN TERMINAL POSITION																DRESS COVER																
										44	43	42	41	39	38	37	36	35	34	33	32	31	30	29	28		27	26	25	24	23	22	21	20	19	18	17	16	15	14	13	12
MX123 CONN ASSY 49 CKT BLK OPT9 KEY A/25	345767893	C-HSG-A9	G-CAP-9-P	TPA-A9	RS	LS	MAL	CPA	MSEAL	RSEAL	-	-	-	-	44	43	42	41	-	39	-	-	-	-	35	SALEABLE		345750003														
											-	33	-	-	30	-	28	27	26	-	-	-	-	21																		
											-	-	-	-	-	18	-	-	-	15	14	13	12	11																		
											-	-	-	-	-	8	7	6	-	4	3	-	1																			
MX123 CONN ASSY 49 CKT BLK OPT0 KEY A/27	345767903	C-HSG-A0	G-CAP-0-P	TPA-A0	RS	LS	MAL	CPA	MSEAL	RSEAL	-	-	-	-	44	43	42	41	-	39	-	-	-	35	SALEABLE		345750003															
											-	33	-	-	30	-	28	27	26	-	-	-	-	21																		
											-	-	-	-	-	18	-	-	-	15	14	13	-	11																		
											-	-	-	-	-	8	7	6	-	4	3	-	-																			
MX123 CONN ASSY 49 CKT BLK OPT9 KEY A/27	345767913	C-HSG-A9	G-CAP-9-P	TPA-A9	RS	LS	MAL	CPA	MSEAL	RSEAL	-	47	-	45	44	-	42	41	40	-	-	37	-	-	SALEABLE		345750003															
											-	-	-	-	30	-	28	-	26	-	-	-	-	-																		
											-	-	-	-	-	18	17	16	15	14	13	12	-																			
											-	-	-	-	-	8	-	-	5	4	3	2	-																			
MX123 CONN ASSY 49 CKT BLK OPT0 KEY A/34	345767923	C-HSG-A0	G-CAP-0-P	TPA-A0	RS	LS	MAL	CPA	MSEAL	RSEAL	-	-	-	-	-	-	42	41	-	39	-	-	-	35	SALEABLE		345750003															
											-	33	-	-	30	-	-	-	26	-	-	-	-	21																		
											-	-	-	-	-	-	-	-	-	-	14	13	-	11																		
											-	-	-	-	-	8	7	-	-	4	3	-	-																			
MX123 CONN ASSY 49 CKT BLU OPT0 KEY C/14	345767933	C-HSG-C0	G-CAP-0-P	TPA-C0	RS	LS	MAL	CPA	MSEAL	RSEAL	48	47	46	45	44	43	42	41	40	39	38	37	36	35	SALEABLE		345750003															
											34	33	32	31	30	29	28	27	26	25	24	23	22	21																		
											-	-	-	-	-	19	-	-	-	15	-	-	-	11																		
											10	-	-	-	-	-	-	-	5	4	-	2	-																			
MX123 CONN ASSY 49 CKT BLK OPT0 KEY A/27	345767943	C-HSG-A0	G-CAP-0-P	TPA-A0	RS	LS	MAL	CPA	MSEAL	RSEAL	-	-	-	-	44	43	42	41	-	39	-	-	-	35	SALEABLE		345750003															
											-	33	-	-	30	-	28	27	26	-	-	-	-	21																		
											-	-	-	-	-	18	17	-	-	14	13	-	11																			
											-	-	-	-	-	8	7	6	-	4	3	-	-																			
MX123 CONN ASSY 49 CKT BLK OPT9 KEY A/26	345767963	C-HSG-A9	G-CAP-9-P	TPA-A9	RS	LS	MAL	CPA	MSEAL	RSEAL	-	47	-	45	44	-	42	41	40	-	-	37	-	-	SALEABLE		345750003															
											-	-	-	-	30	-	28	-	26	-	-	-	22	-																		
											-	-	-	-	-	18	17	16	15	14	13	12	-																			
											-	-	-	-	-	8	-	-	5	4	3	2	-																			
MX123 CONN ASSY 49 CKT BLK OPT0 KEY A/30	345767973	C-HSG-A0	G-CAP-0-P	TPA-A0	RS	LS	MAL	CPA	MSEAL	RSEAL	-	-	-	-	-	-	42	41	-	39	-	-	-	35	SALEABLE		345750003															
											-	33	-	-	30	29	-	-	26	-	-	-	-	21																		
											-	-	-	-	-	18	17	-	-	14	13	-	11																			
											-	-	-	-	-	8	7	6	-	4	3	-	-																			
MX123 CONN ASSY 49 CKT BLK OPT9 KEY A/18	345767983	C-HSG-A9	G-CAP-9-P	TPA-A9	RS	LS	MAL	CPA	MSEAL	RSEAL	48	47	46	45	44	43	42	41	40	39	-	37	36	35	SALEABLE		345750003															
											34	-	-	31	30	-	-	27	-	-	24	-	22	21																		
											-	-	-	-	-	19	-	17	-	-	14	13	12	11																		
											-	-	-	-	-	9	-	-	-	-	4	3	2	1																		
MX123 CONN ASSY 49 CKT BLU OPT9 KEY C/29	345767993	C-HSG-C9	G-CAP-9-P	TPA-C9	RS	LS	MAL	CPA	MSEAL	RSEAL	48	-	46	-	-	43	-	41	-	-	-	-	-	35	SALEABLE		345750003															
											-	33	-	31	-	29	-	27	26	25	-	-	22	-																		
											-	-	-	-	20	19	-	-	16	-	-	-	-	-																		
											-	-	-	-	10	-	8	-	6	-	4	-	2	-																		
MX123 CONN ASSY 49 CKT BLK OPT0 KEY A/31	345768003	C-HSG-A0	G-CAP-0-P	TPA-A0	RS	LS	MAL	CPA	MSEAL	RSEAL	-	-	-	-	-	-	42	41	-	39	-	-	-	35	SALEABLE		345750003															
											-	33	-	-	30	-	-	-	26	-	-	-	-	21																		
											-	-	-	-	-	18	17	-	15	14	13	-	11																			
											-	-	-	-	-	8	7	-	-	4	3	-	-																			
MX123 CONN ASSY 49 CKT BLK OPT9 KEY A/26	345768023	C-HSG-A9	G-CAP-9-P	TPA-A9	RS	LS	MAL	CPA	MSEAL	RSEAL	-	-	-	-	44	43	42	41	-	39	38	-	-	35	SALEABLE		345750003															
											-	33	-	-	30	-	28	27	26	-	-	-	-	21																		
											-	-	-	-	-	-	17	-	15	14	13	-	11																			
											-	-	-	-	-	8	7	6	-	4	3	-	-																			

NUMBER	C-HSG	G-CAP	TPA	RS	LS	MAL	CPA	MSEAL	RSEAL	CAVITY WITH A NUMBER INDICATES BLOCKED TERMINAL POSITION CAVITY WITHOUT A NUMBER INDICATES OPEN TERMINAL POSITION																	DRESS COVER																				
										48	47	46	45	44	43	42	41	40	39	38	37	36	35	34	33	32		31	30	29	28	27	26	25	24	23	22	21	20	19	18	17	16	15	14	13	12
MX123 CONN ASSY 49 CKT BLK OPT9 KEY A/21	345768033	C-HSG-A9	G-CAP-9-P	TPA-A9	RS	LS	MAL	CPA	MSEAL	RSEAL	48	47	46	45	44	43	42	41	40	39	-	37	36	35	SALEABLE	345750003																					
											34	-	-	31	30	-	-	27	-	-	24	-	22	21																							
											-	-	-	-	-	19	-	-	-	-	14	13	12	11																							
											-	-	-	-	-	9	-	-	-	-	-	3	-	1																							
MX123 CONN ASSY 49 CKT BLU OPT9 KEY C/28	345768043	C-HSG-C9	G-CAP-9-P	TPA-C9	RS	LS	MAL	CPA	MSEAL	RSEAL	48	-	46	-	-	43	42	41	-	-	-	-	-	35	SALEABLE	345750003																					
											-	33	-	31	-	29	-	27	26	25	-	-	22	-																							
											-	-	-	-	20	19	-	-	16	-	-	-	-	-																							
											-	-	-	-	10	-	8	-	6	-	4	-	2	-																							
MX123 CONN ASSY 49 CKT BLK OPT0 KEY A/30	345768053	C-HSG-A0	G-CAP-0-P	TPA-A0	RS	LS	MAL	CPA	MSEAL	RSEAL	-	-	-	-	-	-	42	41	-	39	-	-	-	35	SALEABLE	345750003																					
											-	33	-	-	30	-	-	-	26	-	-	-	-	21																							
											-	-	-	-	-	-	18	17	-	15	14	13	-	11																							
											-	-	-	-	-	-	8	7	6	-	4	3	-	-																							
MX123 CONN ASSY 49 CKT BLK OPT9 KEY A/32	345768063	C-HSG-A9	G-CAP-9-P	TPA-A9	RS	LS	MAL	CPA	MSEAL	RSEAL	-	-	-	-	-	-	42	41	-	39	38	-	-	35	SALEABLE	345750003																					
											-	33	-	-	30	-	-	-	26	-	-	-	-	21																							
											-	-	-	-	-	-	-	17	-	-	14	13	-	11																							
											-	-	-	-	-	-	8	7	6	-	4	-	-	-																							
MX123 CONN ASSY 49 CKT BLU OPT0 KEY C/34	345768073	C-HSG-C0	G-CAP-0-P	TPA-C0	RS	LS	MAL	CPA	MSEAL	RSEAL	-	-	-	-	-	43	42	-	-	-	-	-	-	35	SALEABLE	345750003																					
											-	-	-	31	-	29	-	27	26	25	-	-	-	-																							
											-	-	-	-	-	19	-	-	-	15	-	-	-	11																							
											-	-	-	-	10	-	-	-	-	5	4	-	2	-																							
MX123 CONN ASSY 49 CKT BLK OPT0 KEY A/33	345768113	C-HSG-A0	G-CAP-0-P	TPA-A0	RS	LS	MAL	CPA	MSEAL	RSEAL	-	-	-	-	-	-	42	41	-	39	-	-	-	35	SALEABLE	345750003																					
											-	33	-	-	30	-	-	-	26	-	-	-	-	21																							
											-	-	-	-	-	-	-	-	-	-	14	13	-	11																							
											-	-	-	-	-	-	8	7	6	-	4	3	-	-																							
MX123 CONN ASSY 49 CKT BLK OPT0 KEY A/31	345768123	C-HSG-A0	G-CAP-0-P	TPA-A0	RS	LS	MAL	CPA	MSEAL	RSEAL	-	-	-	-	-	-	42	41	-	39	-	-	-	35	SALEABLE	345750003																					
											-	33	-	-	30	29	-	-	26	-	-	-	-	21																							
											-	-	-	-	-	-	18	-	-	-	14	13	-	11																							
											-	-	-	-	-	-	8	7	6	-	4	3	-	-																							
MX123 CONN ASSY 49 CKT BLK OPT0 KEY A/27	345768133	C-HSG-A0	G-CAP-0-P	TPA-A0	RS	LS	MAL	CPA	MSEAL	RSEAL	-	47	-	45	-	-	-	41	-	-	-	37	36	-	SALEABLE	345750003																					
											-	-	-	-	30	-	-	27	-	-	-	-	22	-																							
											-	-	-	-	20	19	18	17	16	15	-	13	12	-																							
											-	-	-	-	10	9	-	-	6	5	4	-	2	-																							
MX123 CONN ASSY 49 CKT BLK OPT0 KEY A/1	345769113	C-HSG-A0	G-CAP-0-P	TPA-A0	RS	LS	MAL	CPA	MSEAL	RSEAL	48	47	46	45	44	43	42	41	40	39	38	37	36	35	SALEABLE	345750003																					
											34	33	32	31	30	29	28	27	26	25	24	23	22	21																							
											-	-	-	-	20	19	18	17	16	15	14	13	12	11																							
											-	-	-	-	10	9	8	7	6	5	4	3	2	1																							
MX123 CONN ASSY 49 CKT BLU OPT0 KEY C/1	345769123	C-HSG-C0	G-CAP-0-P	TPA-C0	RS	LS	MAL	CPA	MSEAL	RSEAL	48	47	46	45	44	43	42	41	40	39	38	37	36	35	SALEABLE	345750003																					
											34	33	32	31	30	29	28	27	26	25	24	23	22	21																							
											-	-	-	-	20	19	18	17	16	15	14	13	12	11																							
											-	-	-	-	10	9	8	7	6	5	4	3	2	1																							
MX123 CONN ASSY 49 CKT BLK OPT9 KEY A/32	345769133	C-HSG-A9	G-CAP-9-P	TPA-A9	RS	LS	MAL	CPA	MSEAL	RSEAL	-	-	-	-	-	-	42	41	-	39	-	-	-	35	SALEABLE	345750003																					
											-	33	-	-	30	-	-	-	26	-	-	-	-	21																							
											-	-	-	-	-	-	-	-	-	15	14	13	-	11																							
											-	-	-	-	-	-	8	7	6	-	4	3	-	-																							
MX123 CONN ASSY 49 CKT BLU OPT9 KEY C/30	345769143	C-HSG-C9	G-CAP-9-P	TPA-C9	RS	LS	MAL	CPA	MSEAL	RSEAL	48	-	46	-	-	43	42	41	-	-	-	-	-	35	SALEABLE	345750003																					
											-	33	-	31	-	29	28	27	-	-	-	-	22	-																							
											-	-	-	-	20	19	-	-	16	-	-	-	-	11																							
											-	-	-	-	-	-	8	-	-	-	4	-	2	-																							

PART NUMBER	NUMBER	C-HSG	G-CAP	TPA	RS	LS	MAL	CPA	MSEAL	RSEAL	CAVITY WITH A NUMBER INDICATES BLOCKED TERMINAL POSITION CAVITY WITHOUT A NUMBER INDICATES OPEN TERMINAL POSITION																SALEABLE		DRESS COVER																																							
											-	-	-	-	-	-	42	41	-	39	-	-	-	-	35	-				33	-	-	30	-	28	27	26	-	-	-	-	21	-	-	-	-	18	17	-	-	14	13	-	11	-	-	-	-	8	7	6	-	4	3	-	-		
MX123 CONN ASSY 49 CKT BLK OPT0 KEY A/29	345769283	C-HSG-A0	G-CAP-0-P	TPA-A0	RS	LS	MAL	CPA	MSEAL	RSEAL	-	-	-	-	-	-	42	41	-	39	-	-	-	-	-	-	35	-	33	-	-	30	-	28	27	26	-	-	-	-	21	-	-	-	-	18	17	-	-	14	13	-	11	-	-	-	-	8	7	6	-	4	3	-	-	SALEABLE		345750003
MX123 CONN ASSY 49 CKT BLU OPT9 KEY C/34	345769293	C-HSG-C9	G-CAP-9-P	TPA-C9	RS	LS	MAL	CPA	MSEAL	RSEAL	-	-	-	-	-	-	42	-	-	-	-	-	-	-	-	-	-	-	-	31	-	29	28	27	26	25	-	-	-	22	-	20	19	-	-	-	15	-	-	-	-	11	-	-	-	-	-	-	-	5	4	-	2	-	SALEABLE		345750003	
MX123 CONN ASSY 49 CKT BLK OPT9 KEY A/23	345769303	C-HSG-A9	G-CAP-9-P	TPA-A9	RS	LS	MAL	CPA	MSEAL	RSEAL	-	47	-	45	44	-	-	41	-	-	-	-	37	36	-	-	33	-	-	30	-	-	-	-	-	-	-	22	-	20	19	18	17	16	15	14	13	12	-	10	9	8	7	-	5	4	3	2	-	SALEABLE		345750003						
MX123 CONN ASSY 49 CKT BLU OPT9 KEY C/31	345769313	C-HSG-C9	G-CAP-9-P	TPA-C9	RS	LS	MAL	CPA	MSEAL	RSEAL	48	-	46	-	-	43	42	41	-	-	-	-	-	-	35	-	33	-	31	-	29	-	-	26	25	-	-	22	-	20	19	-	-	16	-	-	-	-	-	10	-	8	-	-	-	-	-	-	2	-	SALEABLE		345750003					
MX123 CONN ASSY 49 CKT BLK OPT0 KEY A/46	345769323	C-HSG-A0	G-CAP-0-P	TPA-A0	RS	LS	MAL	CPA	MSEAL	RSEAL	-	-	-	-	-	-	-	-	-	-	-	-	-	-	-	-	-	-	-	-	-	-	-	-	-	-	-	-	-	-	-	-	-	-	-	-	-	-	-	-	-	-	-	-	-	6	-	4	3	-	-	SALEABLE		345750003				
MX123 CONN ASSY 49 CKT BLK OPT9 KEY A/30	345769363	C-HSG-A9	G-CAP-9-P	TPA-A9	RS	LS	MAL	CPA	MSEAL	RSEAL	-	-	-	-	-	-	42	41	-	-	38	-	-	-	35	-	33	-	-	30	-	-	-	26	-	-	-	-	21	-	-	-	-	18	17	-	15	14	13	-	11	-	-	8	7	6	-	4	3	-	-	SALEABLE		345750003				
MX123 CONN ASSY 49 CKT BLK OPT0 KEY A/26	345769373	C-HSG-A0	G-CAP-0-P	TPA-A0	RS	LS	MAL	CPA	MSEAL	RSEAL	-	-	-	-	44	43	42	41	-	39	38	-	-	35	-	-	-	-	30	29	28	27	26	-	-	-	-	21	-	-	-	-	18	17	-	-	14	13	-	11	-	-	8	7	6	-	4	3	-	-	SALEABLE		345750003					
MX123 CONN ASSY 49 CKT BLU OPT0 KEY C/32	345769383	C-HSG-C0	G-CAP-0-P	TPA-C0	RS	LS	MAL	CPA	MSEAL	RSEAL	-	-	46	-	-	43	42	-	-	-	-	-	-	35	-	33	-	31	-	29	-	-	26	25	-	-	22	-	20	19	-	-	16	-	-	-	-	-	10	-	8	-	-	-	4	-	2	-	SALEABLE		345750003							
MX123 CONN ASSY 49 CKT BLK OPT9 KEY A/26	345769393	C-HSG-A9	G-CAP-9-P	TPA-A9	RS	LS	MAL	CPA	MSEAL	RSEAL	-	47	-	45	44	-	42	41	40	-	-	37	-	-	-	33	-	-	30	-	28	-	26	-	-	-	22	-	-	-	18	17	-	15	14	13	12	-	-	-	8	-	-	5	4	3	2	-	SALEABLE		345750003							
MX123 CONN ASSY 49 CKT BLK OPT9 KEY A/31	345769403	C-HSG-A9	G-CAP-9-P	TPA-A9	RS	LS	MAL	CPA	MSEAL	RSEAL	-	-	-	-	-	-	42	41	-	39	-	-	-	35	-	33	-	-	30	-	28	27	26	-	-	-	-	21	-	-	-	-	-	-	14	13	-	11	-	-	8	7	6	-	4	3	-	-	SALEABLE		345750003							

20 19 18 17 16 15 14 13 12 11 10 9 8 7 6 5 4 3 2 1

INDEX	
PAGE TITLE	PAGE
TITLE BLOCK	1
PART BLOCK	2
KPC BLOCK	3
COMPONENT TABLE	4
NOTES	5
NOTES	6
WIRE DRESS PACKAGING DIMENSIONS	7
LOCATION AND PACKAGING DIMENSIONS REFERENCING INTERFACE DATUMS B & C	8
LOCATION AND PACKAGING DIMENSIONS REFERENCING INTERFACE DATUM A	9
KEY ID REF - WIRE DRESS OPTION 0	10
KEY ID REF - WIRE DRESS OPTION 9	11
CIRCUIT CONFIGURATIONS	12
CIRCUIT CONFIGURATIONS	13
COMPONENT CONNECTOR INTERFACE	14
COMPONENT CONNECTOR INTERFACE	15
COMPONENT CONNECTOR INTERFACE	16
COMPONENT CONNECTOR INTERFACE	17
COMPONENT CONNECTOR INTERFACE	18
COMPONENT CONNECTOR INTERFACE	19
COMPONENT CONNECTOR INTERFACE	20
COMPONENT CONNECTOR INTERFACE	21
ADDITIONAL COMPONENTS REQUIRED	22

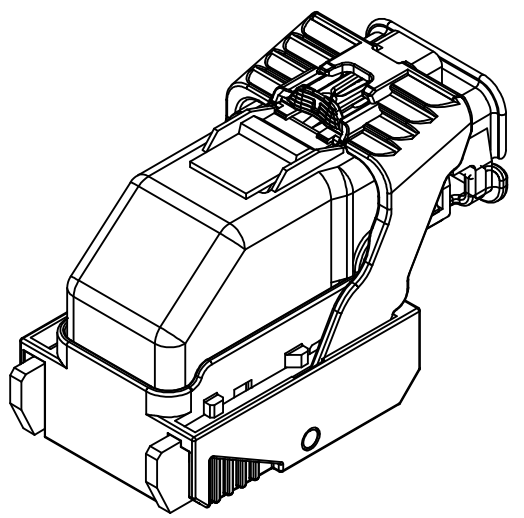

MX123 HARNESS CONN - SEALED
18/49/56 CKTS

ENTER DESCRIPTION EC NO: UAU2017-0870 DRAWN BY: DRWASCHITALIA 2017/03/27 CHKD: APPR: VKOSHY 2017/03/29 A4	QUALITY SYMBOLS ▽=0 ▽=0 ▽=0	GENERAL TOLERANCES (UNLESS SPECIFIED) <table border="1"> <thead> <tr> <th></th> <th>mm</th> <th>INCH</th> </tr> </thead> <tbody> <tr> <td>4 PLACES</td> <td>± 0.15</td> <td>± 0.005</td> </tr> <tr> <td>3 PLACES</td> <td>± 0.10</td> <td>± 0.004</td> </tr> <tr> <td>2 PLACES</td> <td>± 0.13</td> <td>± 0.005</td> </tr> <tr> <td>1 PLACE</td> <td>± 0.25</td> <td>± 0.010</td> </tr> <tr> <td>0 PLACE</td> <td>± 0.30</td> <td>± 0.012</td> </tr> </tbody> </table>		mm	INCH	4 PLACES	± 0.15	± 0.005	3 PLACES	± 0.10	± 0.004	2 PLACES	± 0.13	± 0.005	1 PLACE	± 0.25	± 0.010	0 PLACE	± 0.30	± 0.012	DIMENSION STYLE MM ONLY DRAWN BY: SKRAJENDRANA 2016/12/15 CHECKED BY: VKOSHY 2016/12/15 APPROVED BY: VKOSHY 2017/03/03	SCALE 1:1 DESIGN UNITS METRIC	THIRD ANGLE PROJECTION TITLE: ICD - MX123 18/49/56CKT INTERFACE CONNECTION DRW MOLEX molex MATERIAL NO. SEE BOM TABLE DOCUMENT NO. SD-34576-0001 SHEET NO. 1 OF 22
		mm	INCH																				
	4 PLACES	± 0.15	± 0.005																				
	3 PLACES	± 0.10	± 0.004																				
2 PLACES	± 0.13	± 0.005																					
1 PLACE	± 0.25	± 0.010																					
0 PLACE	± 0.30	± 0.012																					
DRAFT WHERE APPLICABLE MUST REMAIN WITHIN DIMENSIONS		THIS DRAWING CONTAINS INFORMATION THAT IS PROPRIETARY TO MOLEX INCORPORATED AND SHOULD NOT BE USED WITHOUT WRITTEN PERMISSION																					

1b_frame_D_P_AM.T Rev. G 2012/01/11 19 18 17 16 15 14 13 12 11 10 9 8 7 6 5 4 3 2 1

20 19 18 17 16 15 14 13 12 11 10 9 8 7 6 5 4 3 2 1

22	RD	A	C	001		0.000	YAZAKI: 7158-3114-90	2.8MM CAVITY PLUG
21	RD	A		001		0.000	PLUG-WRG HARN CONN MX0.64	
20	RD	A		001		0.000	TERM-AG 0.5MM/0.75MM ISO,MX64	
19	RD	A		001		0.000	TERM-AG 0.35MM ISO,MX64	
18	RD	A	C	006		0.009	WIRE HARNESS COVER	18/49/56 WAY
17	RD	A	2	001		0.041	HARN CONN ASM 56 CKT	KEY J OPTION 9
16	RD	A	2	001		0.041	HARN CONN ASM 56 CKT	KEY H OPTION 9
15	RD	A	2	001		0.041	HARN CONN ASM 56 CKT	KEY G OPTION 9
14	RD	A	2	001		0.041	HARN CONN ASM 56 CKT	KEY J OPTION 0
13	RD	A	2	001		0.041	HARN CONN ASM 56 CKT	KEY H OPTION 0
12	RD	A	2	001		0.041	HARN CONN ASM 56 CKT	KEY G OPTION 0
11	RD	A	2	001		0.040	HARN CONN ASM 49 CKT	KEY C OPTION 9
10	RD	A	2	001		0.040	HARN CONN ASM 49 CKT	KEY B OPTION 9
09	RD	A	2	001		0.040	HARN CONN ASM 49 CKT	KEY A OPTION 9
08	RD	A	2	001		0.040	HARN CONN ASM 49 CKT	KEY C OPTION 0
07	RD	A	2	001		0.040	HARN CONN ASM 49 CKT	KEY B OPTION 0
06	RD	A	2	001		0.040	HARN CONN ASM 49 CKT	KEY A OPTION 0
05	RD	A	2	001		0.044	HARN CONN ASM 18 CKT	KEY H OPTION 9
04	RD	A	2	001		0.044	HARN CONN ASM 18 CKT	KEY G OPTION 9
03	RD	A	2	001		0.044	HARN CONN ASM 18 CKT	KEY H OPTION 0
02	RD	A	2	001		0.044	HARN CONN ASM 18 CKT	KEY G OPTION 0
01	RD	A		001		1.285	HARNASS CONN ASM-SEALED 18/49/56CKTS,MX123	
							DRAWING	
DWG ITM	DWG RLTN SHIP	D L S	ST	REV	P D I	MASS (KG)	PART NAME	NOTES
PARTS SHOWN ON DRAWING								

ENTER DESCRIPTION EC. NO: UAU2017-0870 DRAWN: ACHITALIA 2017/03/27 CHKD: APPR: VKOSHY 2017/03/29 REV: A4	QUALITY SYMBOLS	GENERAL TOLERANCES (UNLESS SPECIFIED)	DIMENSION STYLE	SCALE	DESIGN UNITS	THIRD ANGLE PROJECTION
	▽=0	m/m INCH	MM ONLY	1:1	METRIC	
	▽=0	4 PLACES ± --- ± ---	DRAWN BY DATE			
	▽=0	3 PLACES ± --- ± ---	SKRAJENDRANA 2016/12/15			
	2 PLACES ± 0.13 ± ---	CHECKED BY DATE				TITLE
	1 PLACE ± 0.25 ± ---	VKOSHY 2016/12/15				ICD - MX123 18/49/56CKT INTERFACE CONNECTION DRW MOLEX
	0 PLACE ± --- ± ---	APPROVED BY DATE				molex
		VKOSHY 2017/03/03				
	ANGULAR ± 1 °	MATERIAL NO.	DOCUMENT NO.			SHEET NO.
	DRAFT WHERE APPLICABLE MUST REMAIN WITHIN DIMENSIONS	SEE BOM TABLE	SD-34576-0001			2 OF 22
		THIS DRAWING CONTAINS INFORMATION THAT IS PROPRIETARY TO MOLEX INCORPORATED AND SHOULD NOT BE USED WITHOUT WRITTEN PERMISSION				

1b_frame_D_P_AM.T Rev. G 2012/01/11 19 18 17 16 15 14 13 12 11 10 9 8 7 6 5 4 3 2 1

KEY PRODUCT CHARACTERISTICS
(IN ACCORDANCE WITH QN 1805 OR ON 1050)



SAFETY/COMPLIANCE

TOTAL ON DRAWING

4



FIT/FUNCTION

LAST NO. USED

4

NO	TYPE	DESCRIPTION	RATIONALE	PAGE/ZONE
1	F/F	32.68	IMPROVE CONNECTOR SYSTEM MATING	15
2	F/F	29.00	INSURE PROPER RELEASE OF LEVER	15
3	F/F	15.25	INSURE FINAL MATE POSITION	16
4	F/F	POSITIONAL TOLERANCE (2 PLACES)	INSURE CONNECTOR SYSTEM MATIBILITY	19

ENTER DESCRIPTION EC NO: UAU2017-0870 DRAWN: CHITRALIA 2017/03/27 CHKD: APPR: VKOSHY 2017/03/29 A4	QUALITY SYMBOLS	GENERAL TOLERANCES (UNLESS SPECIFIED)	DIMENSION STYLE	SCALE	DESIGN UNITS	THIRD ANGLE PROJECTION
	▽=0 ▽=0 ▽=0	mm INCH 4 PLACES ± --- ± --- 3 PLACES ± --- ± --- 2 PLACES ± 0.13 ± --- 1 PLACE ± 0.25 ± --- 0 PLACE ± --- ± ---	MM ONLY DRAWN BY DATE SKRAJENDRANA 2016/12/15 CHECKED BY DATE VKOSHY 2016/12/15 APPROVED BY DATE VKOSHY 2017/03/03	1:1 METRIC	ICD - MX123 18/49/56CKT INTERFACE CONNECTION DRW MOLEX	molex
ANGULAR ± 1 ° DRAFT WHERE APPLICABLE MUST REMAIN WITHIN DIMENSIONS		SEE BOM TABLE		DOCUMENT NO. SD-34576-0001		THIS DRAWING CONTAINS INFORMATION THAT IS PROPRIETARY TO MOLEX INCORPORATED AND SHOULD NOT BE USED WITHOUT WRITTEN PERMISSION

20	19	18	17	16	15	14	13	12	11	10	9	8	7	6	5	4	3	2	1
APPLICABLE COMPONENTS																			
Part No.	MFG.	MFG. P/N	DESCRIPTION	Key Option	Wire Dress Option	Key Config.	Color	Status											
1	MOLEX	34575-0003	WIRE HARNESS COVER*	N/A	NA	N/A	BLACK	AVAILABLE											
2	MOLEX	34851-0007	HARN CONN ASM 18 CKT	G	0	1358	BLUE	ACTIVE											
3	MOLEX	34851-0008	HARN CONN ASM 18 CKT	H	0	2458	ST GRAY	ACTIVE											
4	MOLEX	34851-0019	HARN CONN ASM 18 CKT	G	9	1358	BLUE	ACTIVE											
5	MOLEX	34851-0020	HARN CONN ASM 18 CKT	H	9	2458	ST GRAY	ACTIVE											
6	MOLEX	34576-0103	HARN CONN ASM 49 CKT	A	0	1458	BLACK	ACTIVE											
7	MOLEX	34576-0203	HARN CONN ASM 49 CKT	B	0	1468	ST GRAY	NOT ACTIVE											
8	MOLEX	34576-0303	HARN CONN ASM 49 CKT	C	0	2467	BLUE	ACTIVE											
9	MOLEX	34576-1303	HARN CONN ASM 49 CKT	A	9	1458	BLACK	ACTIVE											
10	MOLEX	34576-1403	HARN CONN ASM 49 CKT	B	9	1468	ST GRAY	NOT ACTIVE											
11	MOLEX	34576-1503	HARN CONN ASM 49 CKT	C	9	2467	BLUE	ACTIVE											
12	MOLEX	34576-0703	HARN CONN ASM 56 CKT	G	0	1358	BLUE	AVAILABLE											
13	MOLEX	34576-0803	HARN CONN ASM 56 CKT	H	0	2458	ST GRAY	AVAILABLE											
14	MOLEX	34576-0903	HARN CONN ASM 56 CKT	J	0	2457	BLACK	NOT ACTIVE											
15	MOLEX	34576-1903	HARN CONN ASM 56 CKT	G	9	1358	BLUE	AVAILABLE											
16	MOLEX	34576-2003	HARN CONN ASM 56 CKT	H	9	2458	ST GRAY	NOT ACTIVE											
17	MOLEX	34576-2103	HARN CONN ASM 56 CKT	J	9	2457	BLACK	NOT ACTIVE											
18	MOLEX	34736-0028	MX64 RCPT TERM Ag 0.5mm/0.75mm ISO GAGE B (RIGHT PAYOFF)	N/A	N/A	N/A	N/A	AVAILABLE											
19	MOLEX	34736-0026	MX64 RCPT TERM Ag 0.35mm ISO B (RIGHT PAYOFF)	N/A	N/A	N/A	N/A	AVAILABLE											
20	MOLEX	34586-0001	MX123 0.64MM GROMMET PLUG	N/A	N/A	N/A	NATURAL	AVAILABLE											
21	YAZAKI	7116-4150-02	2.8mm YESC SEALED FEMALE TERMINAL TIN 0.35mm2-0.50mm2	N/A	N/A	N/A	N/A	NOT ACTIVE											
22	YAZAKI	7116-4151-02	2.8mm YESC SEALED FEMALE TERMINAL TIN 0.75mm2-1.0mm2	N/A	N/A	N/A	N/A	NOT ACTIVE											
23	YAZAKI	7116-4152-02	2.8mm YESC SEALED FEMALE TERMINAL TIN 1.5mm2-2.5mm2	N/A	N/A	N/A	N/A	AVAILABLE											
24	YAZAKI	7158-3111-60	2.8mm CABLE SEAL (wire O.D. range 1.2mm-1.9mm)	N/A	N/A	N/A	GREEN	NOT ACTIVE											
25	YAZAKI	7158-3112-70	2.8mm CABLE SEAL (wire O.D. range 1.8mm-2.3mm)	N/A	N/A	N/A	YELLOW	NOT ACTIVE											
26	YAZAKI	7158-3113-40	2.8mm CABLE SEAL (wire O.D. range 2.1mm-3.0mm)	N/A	N/A	N/A	WHITE	AVAILABLE											
27	YAZAKI	7158-3114-90	2.8mm YESC CAVITY PLUG	N/A	N/A	N/A	BLUE	AVAILABLE											
28	DELPHI	33140138	6.35mm APEX RCPT TERM SnAg GRIP CODE-10 (6mm2) - GREASED	N/A	N/A	N/A	N/A	AVAILABLE											
29	DELPHI	33140135	6.35mm APEX RCPT TERM SnAg GRIP CODE-TBD (1mm2) - GREASED	N/A	N/A	N/A	N/A	AVAILABLE											
30	QSR	A-0549C	6.35mm CABLE SEAL (FOR 0.75-1.25mm2 WIRE SIZE - 3.6 TO 4.2mm INSULATION OD)	N/A	N/A	N/A	WHITE	AVAILABLE											
31	QSR	A-0549B	6.35mm CABLE SEAL (FOR 0.75-1.25mm2 WIRE SIZE - 1.8 TO 2.3mm INSULATION OD)	N/A	N/A	N/A	BLUE	AVAILABLE											
32	MOLEX	63825-8400	MX64 TERM HAND CRIMP TOOL	N/A	N/A	N/A	N/A	AVAILABLE											
33	MOLEX	63813-1400	MX64 TERM SERVICE TOOL	N/A	N/A	N/A	N/A	AVAILABLE											
34	MOLEX	63902-5300	MX64 CRIMP APPLICATOR with TOOL KIT 0.5/0.75mm2 PAYOFF DIRECTION D (left payoff) (contact Molex for payoff detail)	N/A	N/A	N/A	N/A	AVAILABLE											
35	MOLEX	63902-5370	MX64 APPLICATOR TOOL KIT 0.5/0.75mm2	N/A	N/A	N/A	N/A	AVAILABLE											
36	MOLEX	63902-5100	MX64 CRIMP APPLICATOR with TOOL KIT 0.35mm2 PAYOFF DIRECTION D (left payoff) (contact Molex for payoff detail)	N/A	N/A	N/A	N/A	AVAILABLE											
37	MOLEX	63902-5170	MX64 APPLICATOR TOOL KIT 0.35mm2	N/A	N/A	N/A	N/A	AVAILABLE											
38	SPX	J35616-64	0.64mm PROBE TOOL (for rcpt)	N/A	N/A	N/A	N/A	AVAILABLE											
39	SPX	J35616-64A	0.64mm PROBE TOOL WITH EXT (for rcpt)	N/A	N/A	N/A	N/A	AVAILABLE											
40	SPX	J35616-65	0.64mm PROBE TOOL WITH EXT (for pin)	N/A	N/A	N/A	N/A	AVAILABLE											
41	SPX	J35616-4A	2.8mm PROBE TOOL (for rcpt)	N/A	N/A	N/A	N/A	AVAILABLE											
42	YAZAKI	X39899-J374	2.8mm TERM SERVICE TOOL	N/A	N/A	N/A	N/A	AVAILABLE											
43	TOI	7000-1001	18CKT PASS THROUGH ADAPTERS	N/A	N/A	N/A	BLACK	AVAILABLE											
44	TOI	7000-1004	49CKT PASS THROUGH ADAPTERS	N/A	N/A	N/A	BLACK	AVAILABLE											
45	TOI	79917-0060	56CKT PASS THROUGH ADAPTERS	N/A	N/A	N/A	BLACK	AVAILABLE											
46	MOLEX	63813-1500	6.35mm APEX TERM SERVICE TOOL	N/A	N/A	N/A	N/A	AVAILABLE											

* MX123 WIRE HARNESS COVER MATES TO ANY 18/49/56 CKT MX123 HARN CONN ASSY SHOWN ON THIS TABLE

ENTER DESCRIPTION EC NO: UAU2017-0870 DRAWN BY: DRWASCHITALIA CHKD: APPR: VKOSHY DATE: 2017/03/15	QUALITY SYMBOLS	GENERAL TOLERANCES (UNLESS SPECIFIED)	DIMENSION STYLE	SCALE	DESIGN UNITS	THIRD ANGLE PROJECTION
	▽=0	mm INCH	MM ONLY	1:1	METRIC	
	▽=0	4 PLACES ± --- ± ---	DRAWN BY: SKRAJENDRANA	DATE: 2016/12/15	TITLE: ICD - MX123 18/49/56CKT INTERFACE CONNECTION DRW	
	▽=0	3 PLACES ± --- ± ---	CHECKED BY: VKOSHY	DATE: 2016/12/15	MOLEX	
		1 PLACE ± 0.25 ± ---	APPROVED BY: VKOSHY	DATE: 2017/03/03	molex	
		0 PLACE ± --- ± ---	MATERIAL NO. SEE BOM TABLE		DOCUMENT NO. SD-34576-0001	SHEET NO. 4 OF 22
ANGULAR ± 1 °			DRAFT WHERE APPLICABLE MUST REMAIN WITHIN DIMENSIONS			
THIS DRAWING CONTAINS INFORMATION THAT IS PROPRIETARY TO MOLEX INCORPORATED AND SHOULD NOT BE USED WITHOUT WRITTEN PERMISSION						

20 19 18 17 16 15 14 13 12 11 10 9 8 7 6 5 4 3 2 1

NOTES: UNLESS OTHERWISE SPECIFIED

1. MATERIAL FOR INTERFACE:

A. RESIN:
 1. 30% G.F. PBT, 20% MAX. (BY WEIGHT) REGRIND.
 2. MATING CONNECTOR INTERFACE PART COLOR MUST BE SAME AS MATCHING KEYED HARNESS CONNECTOR ASSEMBLY.
 3. MUST BE VALIDATED FOR INDIVIDUAL DEVICE APPLICATION REQUIREMENTS.

B. 0.64MM PINS:
 1. BASE MATERIAL: COPPER ALLOY, CONDUCTIVITY >= 28% IACS AT 20°C, TENSILE STRENGTH >= 635 N/mm², SURFACE ROUGHNESS R6 MAX.
 2. PLATING FINISH: SILVER (Ag) PLATING TO BE 1.9-3.3 µm ELECTRODEPOSITED SEMI-BRIGHT SILVER OVER 1.25-2.25 µm DUCTILE SULPHAMATE NICKEL PER NOTE 1(D).
 3. ANTI-TARNISH: SYNTHETIC HYDROCARBON CONTACT SURFACE FINISH OR EQUIVALENT APPLIED WITHOUT VOID TO CONTACT AREA (MIN 3.7mm FROM PIN TIP).

C. 2.8MM BLADE:
 1. BASE MATERIAL: COPPER ALLOY, CONDUCTIVITY >= 28% IACS AT 20°C, TENSILE STRENGTH >= 350 N/mm², SURFACE ROUGHNESS R6 MAX.
 2. PLATING FINISH: TIN PLATING TO BE 2.5-5.0 µm ELECTRODEPOSITED TIN, MATTE FINISH OVER 1.25-2.5µm DUCTILE SULPHAMATE NICKEL PER NOTE 1(D).

D. 6.3MM BLADE:
 1. BASE MATERIAL: COPPER ALLOY, CONDUCTIVITY >= 50% IACS AT 20°C,
 2. PLATING FINISH: SILVER (Ag) PLATING TO BE 1.9-3.3 µm ELECTRODEPOSITED SEMI-BRIGHT SILVER, OVER 1.25-2.5µm DUCTILE SULPHAMATE NICKEL PER NOTE 1(D) WITH ENVIRONMENTAL BARRIER OR
 TIN/SILVER (ELECTRO-DEPOSITED), UNDERPLATE 0.5-2.0 µm NICKEL OR COPPER.
 TOP PLATING: 1.0-3.0 µm (SILVER RANGE 3.75-X.XX NO ANTI-TARNISH COATING REQUIRED).

E. PLATING REQUIREMENTS:
 1. SILVER PLATING
 a. 99.5% PURE SEMI-BRIGHT WITH NO ORGANIC BRIGHTENERS OR CHROMATES.
 2. NICKEL PLATING
 a. ELECTRODEPOSITED DUCTILE SULFAMATE NICKEL WITH A NON-BRIGHTENED FINISH. NO ORGANIC OR BRIGHTENING AGENTS SHALL BE ALLOWED.
 b. SHALL ONLY BE USED AS AN UNDERLYING PLATING AND MAY NOT BE USED AS AN ELECTRICAL CONTACT SURFACE PLATING.
 c. SHALL BE NODULE FREE WHEN VIEWED AT 10X MAGNIFICATION IN MEASURED IN CONTACT SURFACE AREA PLUS 0.5MM PERIMETER AROUND THE CONTACT SURFACE AREA.
 d. ALL PLATINGS SHALL HAVE A 1.0% MAXIMUM BY WEIGHT IMPURITIES. IMPURITIES ARE DEFINED AS ALL ELEMENTS NOT THE PRIMARY PLATING OR HARDENING AGENT IF APPLICABLE, AS DETERMINED BY WET CHEMICAL ANALYSIS OR AUGER METHOD. NO SINGLE IMPURITY SHALL EXCEED 0.1% MAXIMUM BY WEIGHT.
 3. TESTING
 a. THICKNESS TO BE MEASURED IN CONTACT SURFACE AREA PLUS 0.5MM PERIMETER AROUND THE CONTACT SURFACE AREA AS DESIGNATED IN THE DRAWING. THICKNESS SHALL BE DETERMINED BY METHOD OF X-RAY (XRF).
 b. PLATING ADHESION SHALL BE TESTED BY A BEND TEST FOR ALL METALS. THE TEST SAMPLE SHALL BE BENT 90 DEGREES TO DETERMINE DEPOSIT ADHESION. TESTING SHALL BE COMPLETED IN ACCORDANCE WITH ASTM SPEC B571.

2. DESIGN - GENERAL:

A. THIS IS A 100% CAD GENERATED PART. THE CAD MATHEMATICAL DATA IS THE MASTER FOR THIS PART. WHERE DIMENSIONS ARE SPECIFIED ON THE DRAWING, THE DRAWING IS THE AUTHORITY FOR DIMENSIONAL VALUES. FOR DIMENSIONAL OR ANY INFORMATION NOT SHOWN ON THIS DRAWING ANALYZE THE CAD MODEL.
B. DIMENSIONS OBTAINED FROM THE DIGITAL MODEL ARE BASIC:
 1. FOR RELATIONSHIPS BETWEEN FEATURES WHEN ESTABLISHED BY GEOMETRIC TOLERANCES.
 2. FOR THE FORM OF A FEATURE WHEN CONTROLLED BY A PROFILE TOLERANCE.
 3. FOR THE SIZE, FORM AND/OR RELATIONSHIP BETWEEN FIXED DATUM TARGETS.
C. DIMENSIONS OBTAINED FROM THE DIGITAL MODEL ARE ROUNDED TO TWO DECIMAL PLACES (PER IEEE/ASTM SI 10-2002)
D. VIEWS AND SECTIONS ON THIS DRAWING ARE IN ACCORDANCE WITH GM DCS SECTION C3.
E. THE DIGITAL MODEL MUST CORRESPOND TO THE RELEASE LEVEL SHOWN IN THE PART BLOCK ON THIS DOCUMENT.
F. TOLERANCES:
 1. LINEAR 0.X ± 0.30
 0.XX ± 0.10
 0.XXX ± 0.10
 2. ANGULAR X° ± 3°
 3.
G. MINIMUM WALL THICKNESS REQUIRED: 1.3mm.
H. CORNERS SHOWN AS SHARP TO BE R 0.2 MAX.
I. LETTERING SHALL BE 0.15 MAX RAISED IN 0.20 MAX RECESS PAD. THIS INCLUDES MATERIAL CODE, RECYCLING CODE, CAVITY ID AND DATE CODE.
K-1. PARTS MUST BE FREE OF DISCOLORATION, SALT RESIDUE AND OTHER IMPERFECTIONS THAT AFFECT FIT OR FUNCTION.
K-2. SCRATCHES OR DENTS NOT TO EXCEED 0.013mm IN DEPTH.
L. FOLLOWING PRODUCTION CODES TO BE PERMANENTLY MARKED & HUMAN READABLE TO A LETTER HEIGHT OF 1.5 ±0.5MM X 0.3 MAX DEEP
 1. MATERIAL #: XXXXX-XXXX
 2. DATE CODE: JJY (JULIAN DAY, LAST DIGIT OF YEAR)
 3. INSPECTION MACHINE CODE + SERIAL #: X_XXXXX

3. DESIGN - MANUFACTURING:

A. DRAFT TO BE WITHIN TOLERANCE.
B. ALLOWABLE FLASH MAX 0.2 HIGH X MAX 0.13 THICK.
C. ALLOWABLE PARTING LINE MISMATCH 0.2 MAX.
D. EJECTOR PINS MARK TO BE FLUSH TO 0.25 MAX DEPRESSED.
E. ALLOWABLE GATE VESTIGIE FLUSH TO 0.25 MAX PROTRUSION.
F. NO EXTERNAL MOLD RELEASE AGENT ALLOWED DURING MANUFACTURING.
G. STEEL THAT FORMS THE INDICATED SURFACE MUST BE POLISHED WITH A DIAMOND FINISH (SPI A-2) OVER THE FULL PERIPHERY OF THE TOOL. SURFACE MUST HAVE NO MISMATCH.
H. ANY PROCESS LUBRICANT REMAINING ON THE TERMINAL MUST NOT VARNISH OR DEGRADE IT'S ELECTRICAL PERFORMANCE UP TO A MAXIMUM CLASS AMBIENT TEMPERATURE PER SAE USCAR-2 FOR 1008 HOURS. PROCESS LUBRICANTS SHOULD BE APPROVED BY THE RESPONSIBLE ENGINEER.
I. OPTIONAL FEATURES PROVIDED FOR AUTOMATION.
K. PART MUST BE FREE FROM BURRS AND SHARP EDGES, WHICH MIGHT BE DETRIMENTAL TO SATISFACTORY ASSEMBLY, SAFE HANDLING OR FUNCTION OF PART.
L. PARTS AS DELIVERED TO ASSEMBLY SHALL BE CLEAN AND FREE OF DEBRIS, RESIDUAL ABRASIVE MATERIAL AND CORROSION PRODUCTS ADVERESLY AFFECTING FUNCTION OR APPEARANCE.
M. RESTRICTED AND REPORTABLE SUBSTANCES FOR PARTS PER GMW3059.

ENTER DESCRIPTION IEC NO: UAU2017-0870 DRAWN BY: A4 CHKD: DRWACHITALIA APPR: VKOSHY REL: 2017/03/17	QUALITY SYMBOLS ▽=0 ▽=0 ▽=0	GENERAL TOLERANCES (UNLESS SPECIFIED)		DIMENSION STYLE MM ONLY	SCALE 1:1	DESIGN UNITS METRIC	THIRD ANGLE PROJECTION
		4 PLACES ± --- ± --- 3 PLACES ± --- ± --- 2 PLACES ± 0.13 ± --- 1 PLACE ± 0.25 ± --- 0 PLACE ± --- ± ---	m/m INCH SKRA JENDRANA 2016/12/15 CHECKED BY: VKOSHY 2016/12/15 APPROVED BY: VKOSHY 2017/03/03	DRAWN BY: SKRA JENDRANA 2016/12/15 DATE: 2016/12/15 CHECKED BY: VKOSHY 2016/12/15 DATE: 2016/12/15 APPROVED BY: VKOSHY 2017/03/03 DATE: 2017/03/03	TITLE ICD - MX123 18/49/56CKT INTERFACE CONNECTION DRW MOLEX	MATERIAL NO. SEE BOM TABLE	DOCUMENT NO. SD-34576-0001
DRAFT WHERE APPLICABLE MUST REMAIN WITHIN DIMENSIONS		THIS DRAWING CONTAINS INFORMATION THAT IS PROPRIETARY TO MOLEX INCORPORATED AND SHOULD NOT BE USED WITHOUT WRITTEN PERMISSION					

1d:\frame_0_p_am.t Rev. G 2012/01/11 19 18 17 16 15 14 13 12 11 10 9 8 7 6 5 4 3 2 1

20 19 18 17 16 15 14 13 12 11 10 9 8 7 6 5 4 3 2 1

NOTES: UNLESS OTHERWISE SPECIFIED

4. SYSTEM REQUIREMENTS:

A. HARNESS CONNECTOR IS COMPATIBLE WITH THE FOLLOWING WIRE SIZE NO'S:
 0.35mm2, MEETING GMW15626 - MIN OD OF 1.20MM
 0.50mm2, MEETING GMW15626 - MIN OD OF 1.20MM
 0.75mm2, MEETING GMW15626 - MAX OD OF 2.06MM

B. CABLE TIE SPECIFICATIONS:

1. CABLE TIE:
 TENSILE RATING: 220N / (50lbs) MIN
 TIE LENGTH: 180mm MIN
 TIE WIDTH: 4.75mm MAX
 MATERIAL: NYLON

2. INSTALLATION:
 CABLE TIE TENSION: 190N MIN
 3. DRESSED WIRE BUNDLE PACKAGING: SEE FIG. 1

C. WHEN MATED WITH COMPONENT CONNECTOR INTERFACE AND/OR DRESS COVER, HARNESS CONNECTOR SYSTEM CONFORMS TO THE FOLLOWING:

1. SAE/USCAR-2, REV: 3 APRIL, 2001, CLASS 3
 2. FIELD CORRELATED LIFE TEST, SAE/USCAR-20, NOV, 2001
 3. GMW #3191 AUGUST 22, 2000 (DRAFT), TEMPERATURE CLASS 3 (145°C), SEALING CLASS 1 (HIGH PRESSURE SPRAY), VIBRATION CLASS 2 (ON BODY)
 4. TPA USER FORCES (FULLY POPULATED WITH TERMINALS)
 a. REMOVAL FROM LOCK TO PRE-SET: <=120N

D. WIRE SPECIFICATIONS:

1. WIRE SURFACE MUST BE FREE OF SCRATCHES, GROOVES OR DENTS WHERE FUNCTIONAL

5. TERMINAL CURRENT RATINGS:

A. MX64 RCPT TERM
 ALL TESTING DONE IN ACCORDANCE WITH USCAR-2 REV5 SECTION 5.3

1. MX64 RCPT TERM Ag 0.50/0.75mm2 CRIMPED TO 0.75mm2 ISO WIRE AND MATED TO MX123 0.64MM PIN: SEE TABLE BELOW
 2. MX64 RCPT TERM Ag 0.35mm2 CRIMPED TO 0.35mm2 ISO WIRE AND MATED TO MX123 0.64MM PIN: SEE TABLE BELOW

WIRE	CURRENT RATING			
	23 °C	85 °C	105 °C	125 °C
0.75mm2	11.3A	11.3A	9.5A	6.6A
0.50mm2	10.0A	10.0A	8.3A	5.7A
0.35mm2	8.5A	8.5A	7.1A	5.0A

B. 2.8MM RCPT TERM

ALL TESTING DONE IN ACCORDANCE WITH MOLEX DVP&R 0279 (TR# 7125)

1. 2.8MM RCPT TERM TIN 2.0mm2 CRIMPED TO 2.0mm2 ISO WIRE AND MATED TO MX123 2.8MM BLADE: 25.6 AMPS AT 125°C

C. 6.3MM RCPT TERM - DELPHI APEX

ALL TESTING DONE IN ACCORDANCE WITH USCAR-2 REV5 SECTION 5.3

1. 6.3MM RCPT TERM TIN/SILVER CRIMPED TO 6.0MM BLADE (Sn/Ag PLATED): 36A AT 125°C

6. CONTACT MOLEX AUTOMOTIVE FOR AVAILABLE CUSTOM PATTERNS OF CAVITIES OPEN FOR CIRCUITS - SEE GM DRAWING 13507495

ENTER DESCRIPTION EC NO: UAU2017-0870 DRW: ACHITALIA 2017/03/17 CHKD: APPR: VKOSHY 2017/03/19	QUALITY SYMBOLS	GENERAL TOLERANCES (UNLESS SPECIFIED)	DIMENSION STYLE	SCALE	DESIGN UNITS	THIRD ANGLE PROJECTION
	▽=0	m/m INCH	MM ONLY	1:1	METRIC	
	▽=0	4 PLACES ± --- ± ---	DRAWN BY DATE			
	▽=0	3 PLACES ± --- ± ---	SKRAJENDRANA 2016/12/15			
	2 PLACES ± 0.13 ± ---	CHECKED BY DATE				TITLE
	1 PLACE ± 0.25 ± ---	VKOSHY 2016/12/15				ICD - MX123 18/49/56CKT
	0 PLACE ± --- ± ---	APPROVED BY DATE				INTERFACE CONNECTION DRW
		VKOSHY 2017/03/03				MOLEX
		ANGULAR ± 1 °	MATERIAL NO.	DOCUMENT NO.		
		DRAFT WHERE APPLICABLE MUST REMAIN WITHIN DIMENSIONS	SEE BOM TABLE	SD-34576-0001		
			SIZE D	THIS DRAWING CONTAINS INFORMATION THAT IS PROPRIETARY TO MOLEX INCORPORATED AND SHOULD NOT BE USED WITHOUT WRITTEN PERMISSION		SHEET NO. 6 OF 22

1b_frame_D_P_AH.T Rev. G 2012/01/11 19 18 17 16 15 14 13 12 11 10 9 8 7 6 5 4 3 2 1

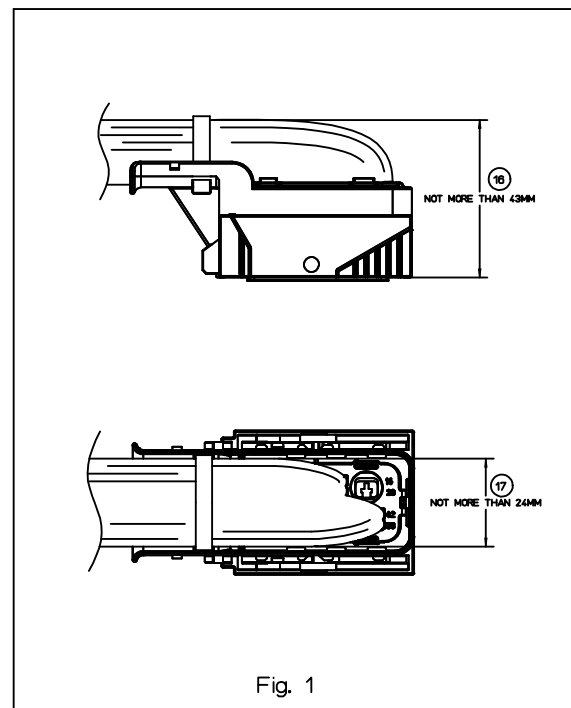
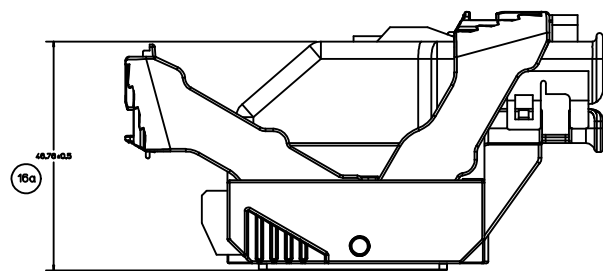

ENTER DESCRIPTION EC NO: UAU2017-0870 DRW: NACHITALIA 2017/03/27 CHKD: APPR: VKOSHY 2017/03/29 REV:	QUALITY SYMBOLS	GENERAL TOLERANCES (UNLESS SPECIFIED)	DIMENSION STYLE	SCALE	DESIGN UNITS	THIRD ANGLE PROJECTION
	▽=0	m/m INCH	MM ONLY	1:1	METRIC	THIRD ANGLE PROJECTION
	▽=0	4 PLACES ± --- ± ---	DRAWN BY DATE			TITLE
	▽=0	3 PLACES ± --- ± ---	SKRAJENDRANA 2016/12/15			ICD - MX123 18/49/56CKT INTERFACE CONNECTION DRW MOLEX
▽=0	2 PLACES ± 0.13 ± ---	CHECKED BY DATE				
	1 PLACE ± 0.25 ± ---	VKOSHY 2016/12/15				
	0 PLACE ± --- ± ---	APPROVED BY DATE				
		VKOSHY 2017/03/03				
		ANGULAR ± 1 °	MATERIAL NO.	DOCUMENT NO.		SHEET NO.
		DRAFT WHERE APPLICABLE MUST REMAIN WITHIN DIMENSIONS	SEE BOM TABLE	SD-34576-0001		7 OF 22
			THIS DRAWING CONTAINS INFORMATION THAT IS PROPRIETARY TO MOLEX INCORPORATED AND SHOULD NOT BE USED WITHOUT WRITTEN PERMISSION			

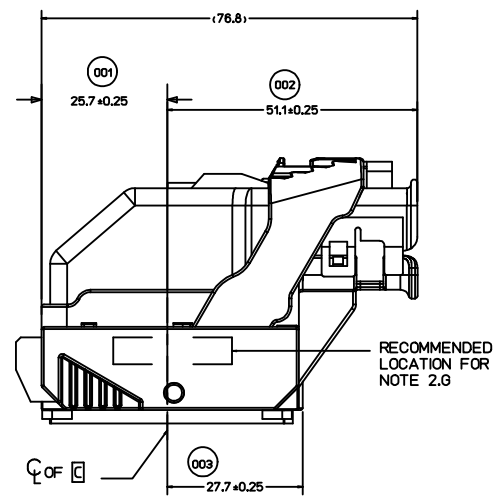

WIRE DRESS OPTION 0 SHOWN

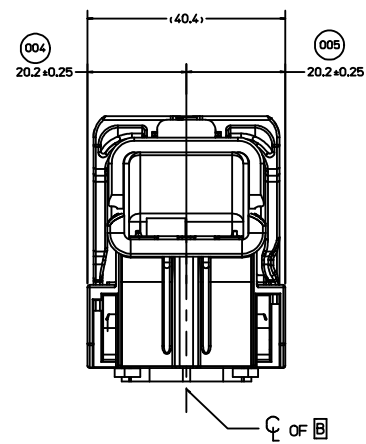

WIRE DRESS OPTION 0 SHOWN

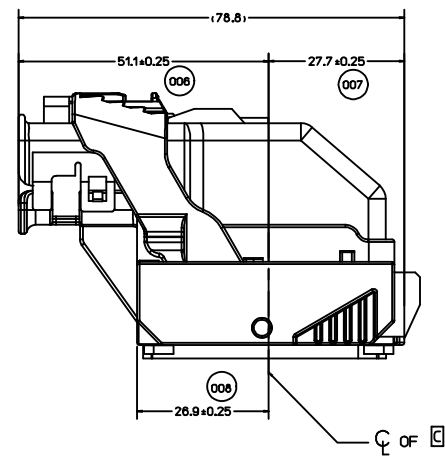

WIRE DRESS OPTION 9 SHOWN

ENTER DESCRIPTION EC. NO: UAU2017-0870 DRAWN: CHITALIA 2017/03/27 CHKD: APPR: VKOSHY 2017/03/29 REV:	QUALITY SYMBOLS	GENERAL TOLERANCES (UNLESS SPECIFIED)	DIMENSION STYLE	SCALE	DESIGN UNITS	THIRD ANGLE PROJECTION
	▽=0	mm INCH	MM ONLY	1:1	METRIC	
	▽=0	4 PLACES ± --- ± ---	DRAWN BY DATE			
	▽=0	3 PLACES ± --- ± ---	SKRAJENDRANA 2016/12/15			
	2 PLACES ± 0.13 ± ---	CHECKED BY DATE	TITLE			
	1 PLACE ± 0.25 ± ---	VKOSHY 2016/12/15	ICD - MX123 18/49/56CKT			
	0 PLACE ± --- ± ---	APPROVED BY DATE	INTERFACE CONNECTION DRW			
		VKOSHY 2017/03/03	MOLEX			
			MATERIAL NO.	DOCUMENT NO.	SHEET NO.	
					8 OF 22	
			SEE BOM TABLE SD-34576-0001			
			THIS DRAWING CONTAINS INFORMATION THAT IS PROPRIETARY TO MOLEX INCORPORATED AND SHOULD NOT BE USED WITHOUT WRITTEN PERMISSION			

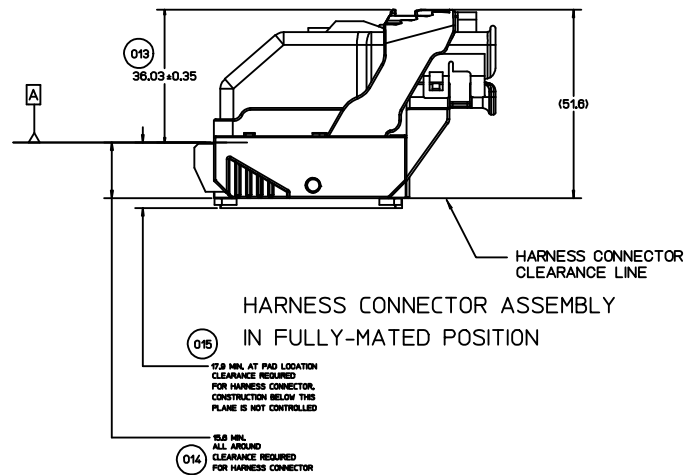
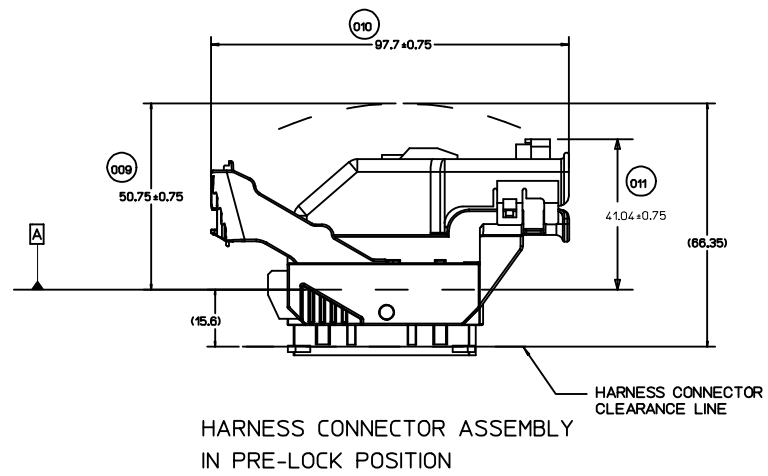
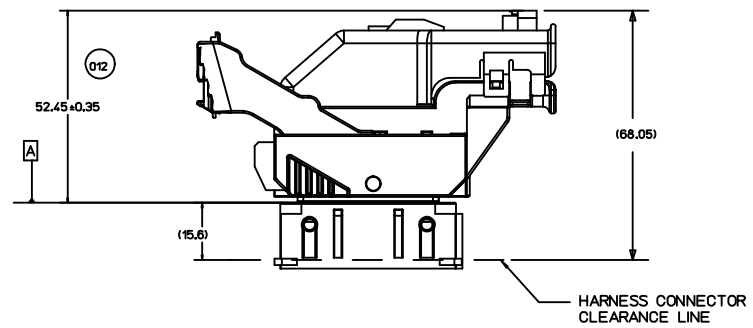

ENTER DESCRIPTION EC NO: UAU2017-0870 DRAWN BY: DR. NAGHATI A CHKD: APPR: VKOSHY 2017/03/29	QUALITY SYMBOLS ∇=0 ∇=0 ∇=0	GENERAL TOLERANCES (UNLESS SPECIFIED)		DIMENSION STYLE MM ONLY	SCALE 1:1	DESIGN UNITS METRIC	THIRD ANGLE PROJECTION
		4 PLACES ± --- ± --- 3 PLACES ± --- ± --- 2 PLACES ± 0.13 ± --- 1 PLACE ± 0.25 ± --- 0 PLACE ± --- ± ---	mm INCH	DRAWN BY: SKRAJENDRANA 2016/12/15 DATE CHECKED BY: VKOSHY 2016/12/15 DATE APPROVED BY: VKOSHY 2017/03/03 DATE	TITLE ICD - MX123 18/49/56CKT INTERFACE CONNECTION DRW MOLEX	MOLEX	MATERIAL NO. SEE BOM TABLE
DRAFT WHERE APPLICABLE MUST REMAIN WITHIN DIMENSIONS		THIS DRAWING CONTAINS INFORMATION THAT IS PROPRIETARY TO MOLEX INCORPORATED AND SHOULD NOT BE USED WITHOUT WRITTEN PERMISSION					

20 19 18 17 16 15 14 13 12 11 10 9 8 7 6 5 4 3 2 1

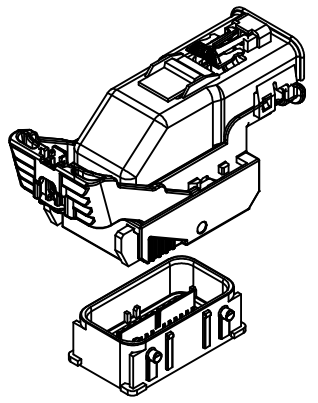
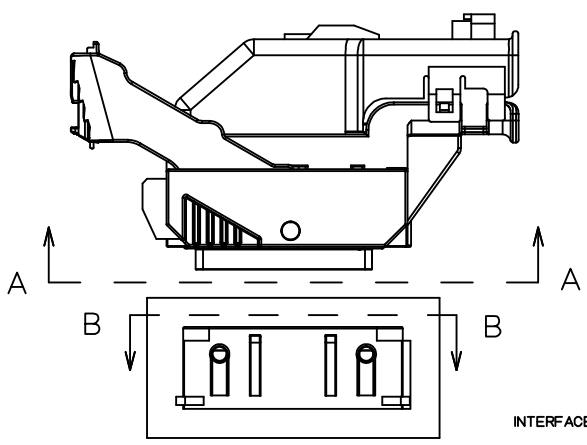

NOTE: REFERENCE THE COMPONENT TABLE FOR KEY OPTIONS AND CONFIGURATIONS

INTERFACE SIDE SHOWN IN ALL SECTION VIEWS

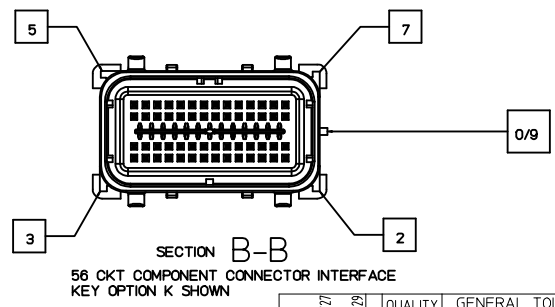
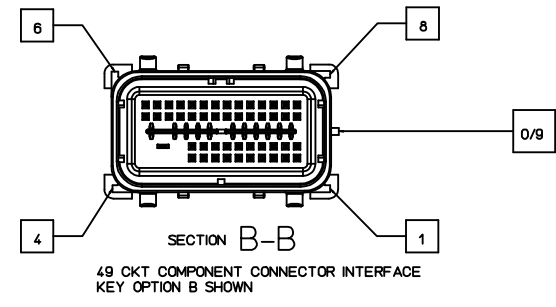
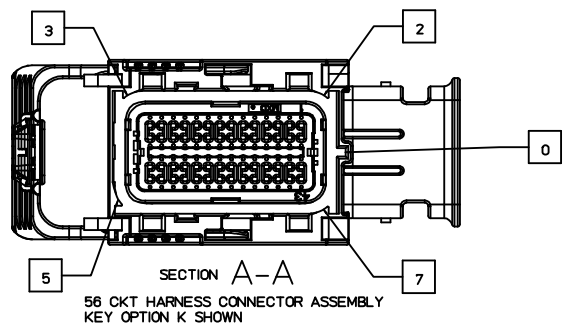
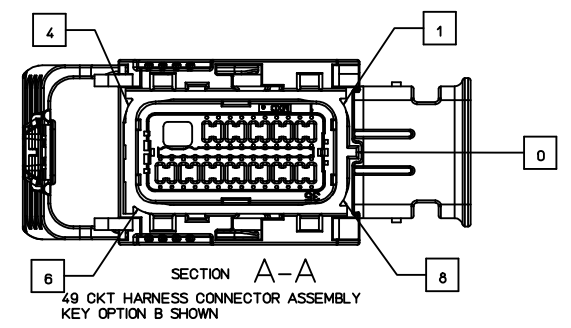

ENTER DESCRIPTION EC NO: UAU2017-0870 DRAWN BY: DRWACHITALIA CHKD: APPR: VKOSHY 2017/03/29 2017/03/29	QUALITY SYMBOLS	GENERAL TOLERANCES (UNLESS SPECIFIED)	DIMENSION STYLE	SCALE	DESIGN UNITS	THIRD ANGLE PROJECTION
	▽=0	m/m INCH	MM ONLY	1:1	METRIC	
	▽=0	4 PLACES ± --- ± ---	DRAWN BY: SKRA JENDRANA	DATE: 2016/12/15	TITLE: ICD - MX123 18/49/56CKT INTERFACE CONNECTION DRW	
	▽=0	3 PLACES ± --- ± ---	CHECKED BY: VKOSHY	DATE: 2016/12/15	MOLEX	
	2 PLACES ± 0.13 ± ---	1 PLACE ± 0.25 ± ---	APPROVED BY: VKOSHY	DATE: 2017/03/03	MATERIAL NO. DOCUMENT NO. SHEET NO.	
	0 PLACE ± --- ± ---	ANGULAR ± 1 °	SEE BOM TABLE		SD-34576-0001 10 OF 22	
DRAFT WHERE APPLICABLE MUST REMAIN WITHIN DIMENSIONS		THIS DRAWING CONTAINS INFORMATION THAT IS PROPRIETARY TO MOLEX INCORPORATED AND SHOULD NOT BE USED WITHOUT WRITTEN PERMISSION				

10 OF 22

20 19 18 17 16 15 14 13 12 11 10 9 8 7 6 5 4 3 2 1

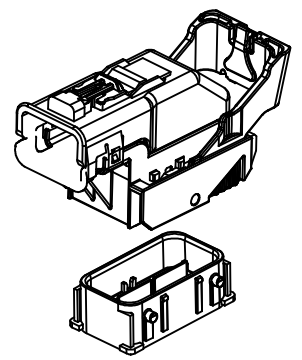
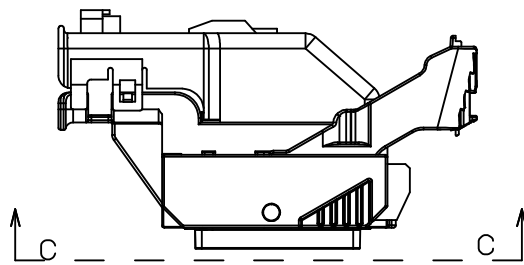

NOTE: REFERENCE THE COMPONENT TABLE FOR KEY OPTIONS AND CONFIGURATIONS

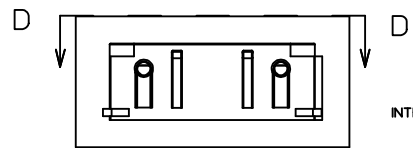

INTERFACE SIDE SHOWN ON ALL SECTION VIEWS

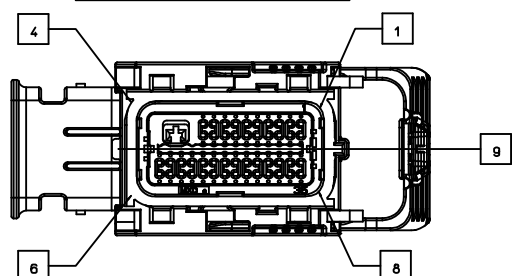

SECTION C-C
49 CKT HARNESS CONNECTOR ASSEMBLY
KEY OPTION B SHOWN

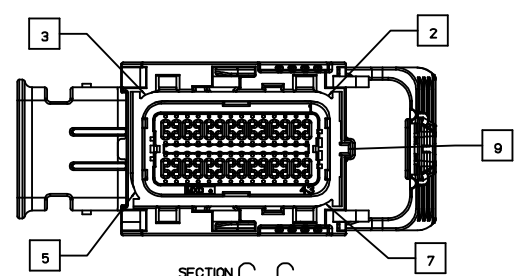

SECTION C-C
56 CKT HARNESS CONNECTOR ASSEMBLY
KEY OPTION K SHOWN

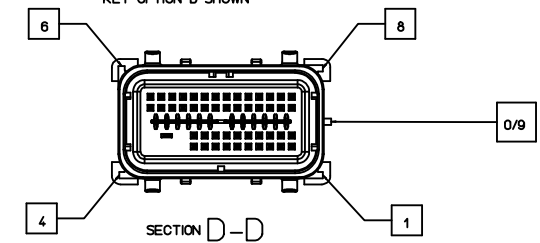

SECTION D-D
49 CKT COMPONENT CONNECTOR INTERFACE
KEY OPTION B SHOWN

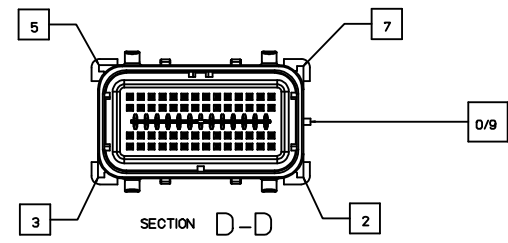

SECTION D-D
56 CKT COMPONENT CONNECTOR INTERFACE
KEY OPTION K SHOWN

ENTER DESCRIPTION EC. NO: UAU2017-0870 DRAWN: CRITALLIA 2017/03/27 CHKD: APPR: VKOSHY 2017/03/29 REV:	QUALITY SYMBOLS	GENERAL TOLERANCES (UNLESS SPECIFIED)	DIMENSION STYLE	SCALE	DESIGN UNITS	THIRD ANGLE PROJECTION
	▽=0	mm INCH	MM ONLY	1:1	METRIC	
	▽=0	4 PLACES ± --- ± ---	DRAWN BY DATE			
	▽=0	3 PLACES ± --- ± ---	SKRAJENDRANA 2016/12/15	TITLE		
	2 PLACES ± 0.13 ± ---	CHECKED BY DATE	ICD - MX123 18/49/56CKT			
	1 PLACE ± 0.25 ± ---	VKOSHY 2016/12/15	INTERFACE CONNECTION DRW			
	0 PLACE ± --- ± ---	APPROVED BY DATE	MOLEX			
		VKOSHY 2017/03/03	MATERIAL NO.	DOCUMENT NO.	SHEET NO.	
					11 OF 22	
			SEE BOM TABLE SD-34576-0001			
			THIS DRAWING CONTAINS INFORMATION THAT IS PROPRIETARY TO MOLEX INCORPORATED AND SHOULD NOT BE USED WITHOUT WRITTEN PERMISSION			

1b_frame_D_P_AM.T Rev. G 2012/01/11 19 18 17 16 15 14 13 12 11 10 9 8 7 6 5 4 3 2 1

20 19 18 17 16 15 14 13 12 11 10 9 8 7 6 5 4 3 2 1

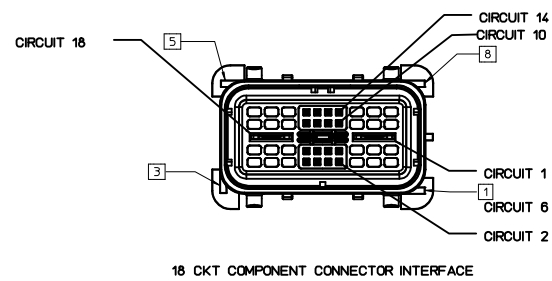
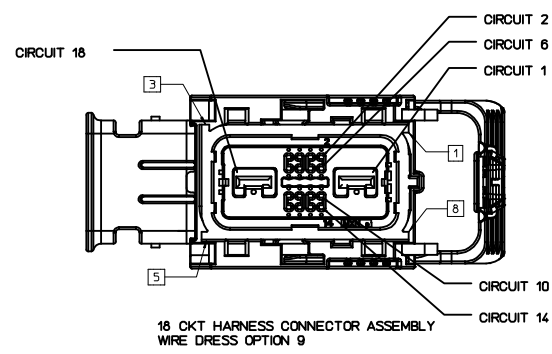
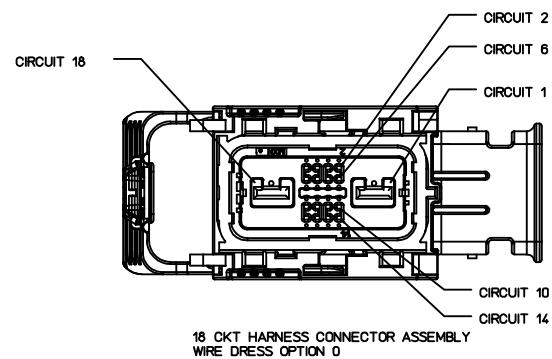

INTERFACE SIDE SHOWN ON ALL VIEWS

ENTER DESCRIPTION EC. NO: UAU2017-0870 DRAWN: CRITALLIA 2017/03/27 CHKD: APPR: VKOSHY REL:	QUALITY SYMBOLS	GENERAL TOLERANCES (UNLESS SPECIFIED)	DIMENSION STYLE	SCALE	DESIGN UNITS	THIRD ANGLE PROJECTION
	▽=0	m/m INCH	MM ONLY	1:1	METRIC	
	▽=0	4 PLACES ± --- ± ---	DRAWN BY DATE			
	▽=0	3 PLACES ± --- ± ---	SKRAJENDRANA 2016/12/15			
	2 PLACES ± 0.13 ± ---	CHECKED BY DATE				TITLE
	1 PLACE ± 0.25 ± ---	VKOSHY 2016/12/15				ICD - MX123 18/49/56CKT INTERFACE CONNECTION DRW MOLEX
	0 PLACE ± --- ± ---	APPROVED BY DATE				molex
		VKOSHY 2017/03/03				
	ANGULAR ± 1 °	MATERIAL NO.				DOCUMENT NO.
	DRAFT WHERE APPLICABLE MUST REMAIN WITHIN DIMENSIONS	SEE BOM TABLE				SD-34576-0001
		SIZE D				SHEET NO. 12 OF 22
						THIS DRAWING CONTAINS INFORMATION THAT IS PROPRIETARY TO MOLEX INCORPORATED AND SHOULD NOT BE USED WITHOUT WRITTEN PERMISSION

19 18 17 16 15 14 13 12 11 10 9 8 7 6 5 4 3 2 1

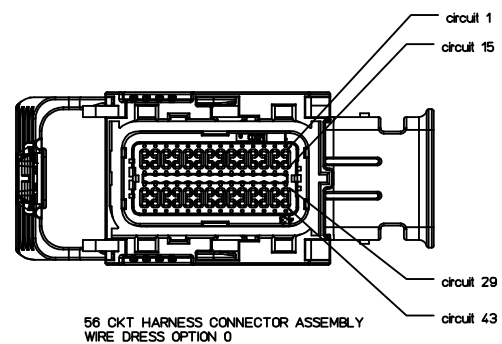
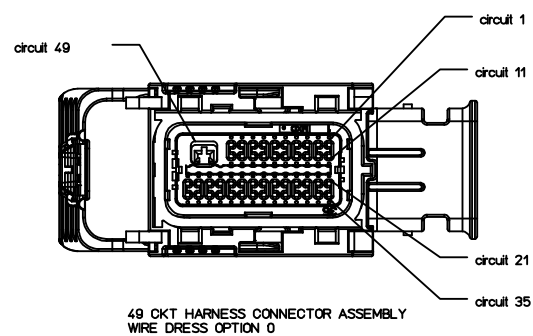

INTERFACE SIDE SHOWN ON ALL VIEWS

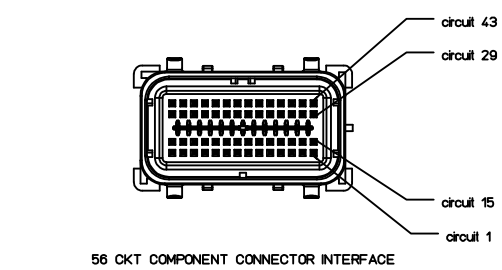
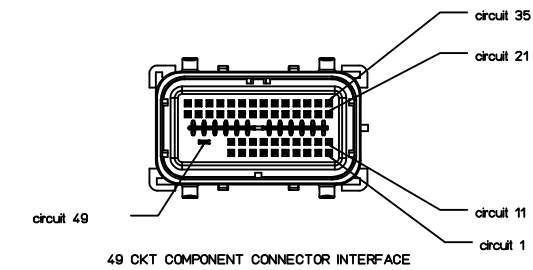
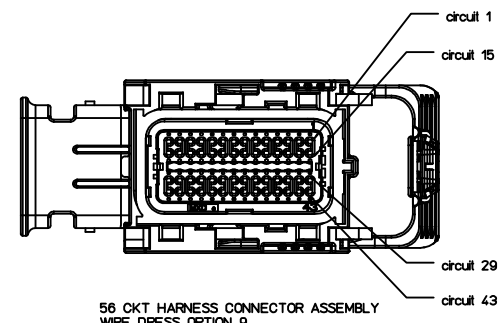
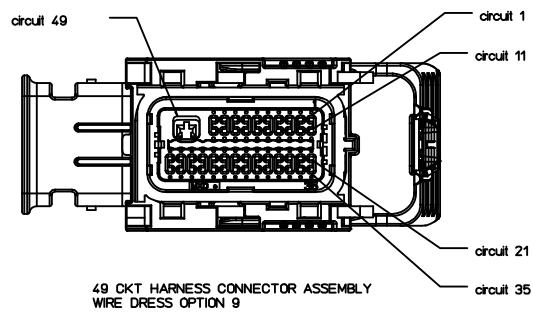

ENTER DESCRIPTION EC NO: UAU2017-0870 DRAWN BY: DRWASCHITALIA 2017/03/27 CHKD: APPR: VKOSHY 2017/03/29	QUALITY SYMBOLS	GENERAL TOLERANCES (UNLESS SPECIFIED)	DIMENSION STYLE	SCALE	DESIGN UNITS	THIRD ANGLE PROJECTION
	▽=0	m/m INCH	MM ONLY	1:1	METRIC	
	▽=0	4 PLACES ± --- ± ---	DRAWN BY DATE			
	▽=0	3 PLACES ± --- ± ---	SKRAJENDRANA 2016/12/15			
▽=0	2 PLACES ± 0.13 ± ---	CHECKED BY DATE				TITLE
▽=0	1 PLACE ± 0.25 ± ---	VKOSHY 2016/12/15				ICD - MX123 18/49/56CKT
▽=0	0 PLACE ± --- ± ---	APPROVED BY DATE				INTERFACE CONNECTION DRW
		VKOSHY 2017/03/03				MOLEX
			MATERIAL NO.	DOCUMENT NO.		
			SEE BOM TABLE	SD-34576-0001		SHEET NO.
			THIS DRAWING CONTAINS INFORMATION THAT IS PROPRIETARY TO MOLEX INCORPORATED AND SHOULD NOT BE USED WITHOUT WRITTEN PERMISSION			13 OF 22

20 19 18 17 16 15 14 13 12 11 10 9 8 7 6 5 4 3 2 1

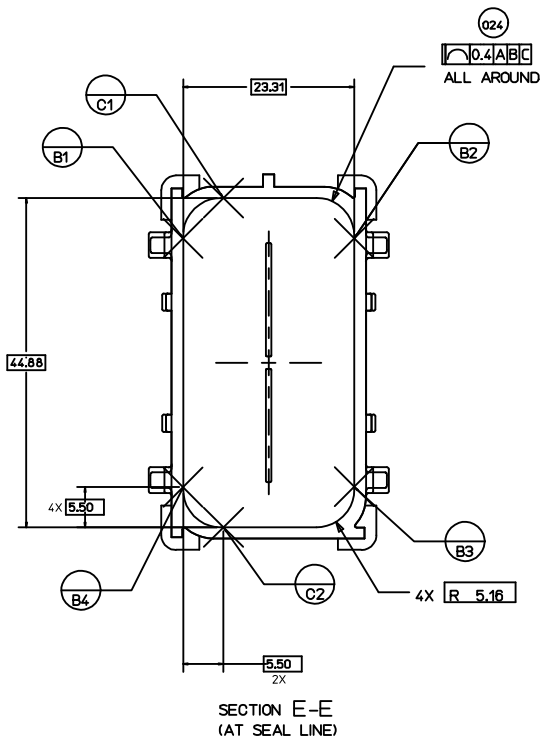
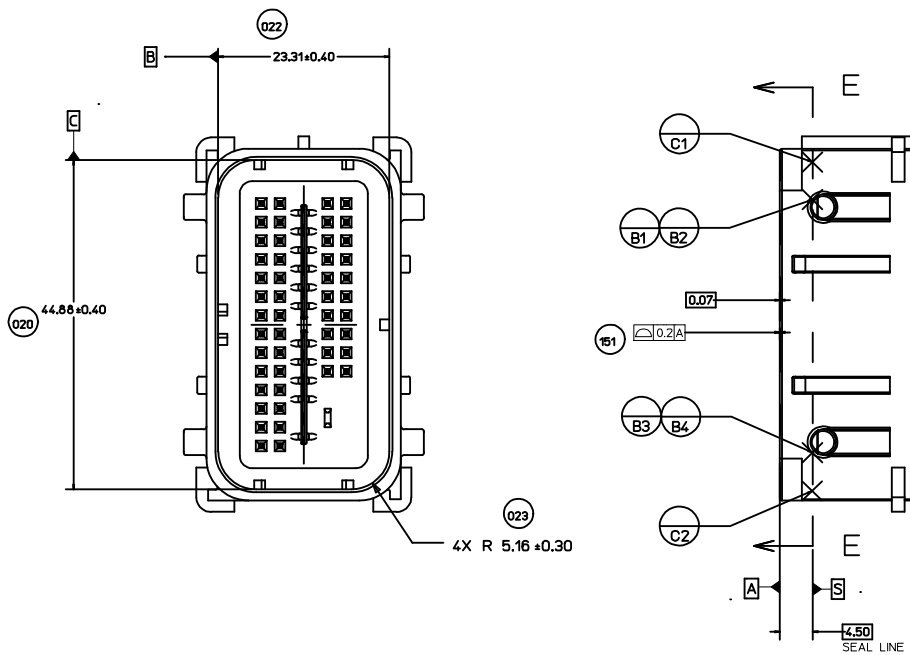
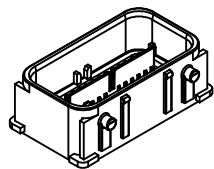

UNLESS SPECIFIED, TOLERANCE OF THE DEVICE INTERFACE TO BE ± 0.13 A B C

ENTER DESCRIPTION IEC NO: UAU2017-0870 DRAWN: ACHITALIA 2017/03/27 CHKD: APPR: VKOSHY 2017/03/29 A4	QUALITY SYMBOLS	GENERAL TOLERANCES (UNLESS SPECIFIED)	DIMENSION STYLE	SCALE	DESIGN UNITS	THIRD ANGLE PROJECTION
	▽=0	mm INCH	MM ONLY	1:1	METRIC	THIRD ANGLE PROJECTION
	▽=0	4 PLACES ± --- ± ---	DRAWN BY DATE	SKRA JENDRANA 2016/12/15	TITLE	ICD - MX123 18/49/56CKT
	▽=0	3 PLACES ± --- ± ---	CHECKED BY DATE	VKOSHY 2016/12/15	INTERFACE CONNECTION DRW	MOLEX
▽=0	2 PLACES ± 0.13 ± ---	APPROVED BY DATE	VKOSHY 2017/03/03	MATERIAL NO.	SD-34576-0001	SHEET NO. 14 OF 22
▽=0	1 PLACE ± 0.25 ± ---	0 PLACE ± --- ± ---	ANGULAR ± 1 °	THIS DRAWING CONTAINS INFORMATION THAT IS PROPRIETARY TO MOLEX INCORPORATED AND SHOULD NOT BE USED WITHOUT WRITTEN PERMISSION		

ib: frame_D_P_AM.T Rev. G 2012/01/11

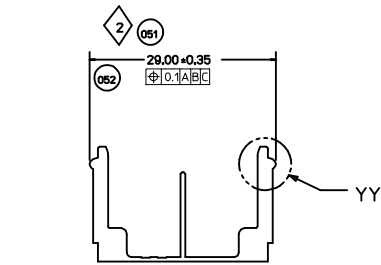
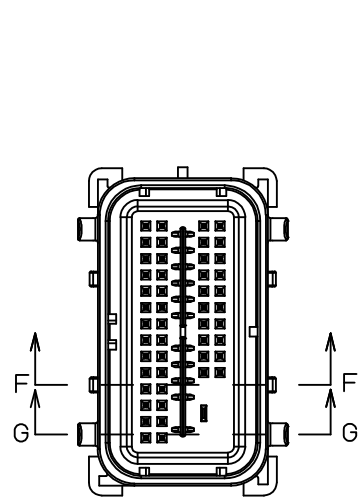

SECTION F-F
(RELEASE FEATURE)

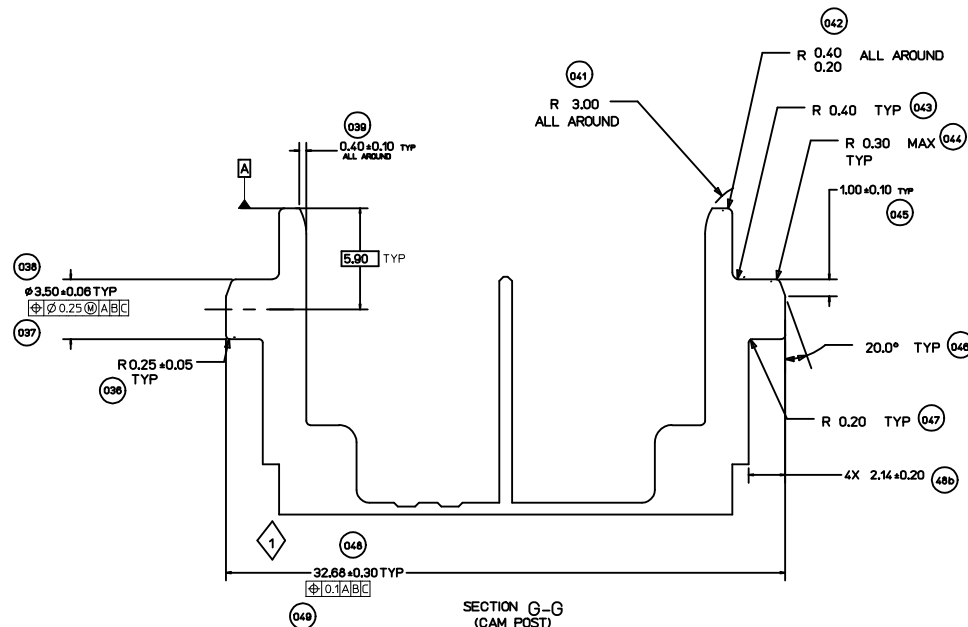
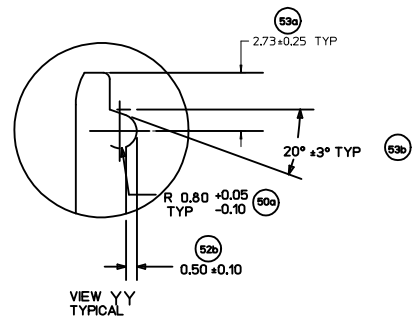
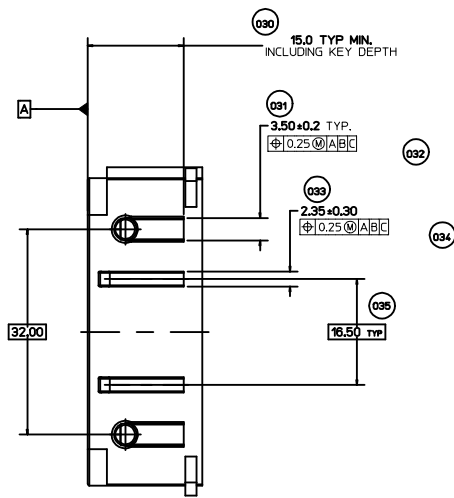

ENTER DESCRIPTION EC NO: UAU2017-0870 DRW: ACHITALIA - 2817/03/17 CHK: [blank] APPR: VKOSHY DATE: 28/11/2017	QUALITY SYMBOLS ∇=0 ∇=0 ∇=0	GENERAL TOLERANCES (UNLESS SPECIFIED)		DIMENSION STYLE MM ONLY	SCALE 1:1	DESIGN UNITS METRIC	THIRD ANGLE PROJECTION
		4 PLACES ± --- ± --- 3 PLACES ± --- ± --- 2 PLACES ± 0.13 ± --- 1 PLACE ± 0.25 ± --- 0 PLACE ± --- ± ---	mm INCH	DRAWN BY: SKRAJENDRANA DATE: 2016/12/15 CHECKED BY: VKOSHY DATE: 2016/12/15 APPROVED BY: VKOSHY DATE: 2017/03/03	TITLE: ICD - MX123 18/49/56CKT INTERFACE CONNECTION DRW MOLEX	MATERIAL NO: SD-34576-0001	SHEET NO. 15 OF 22
ANGLULAR ± 1° DRAFT WHERE APPLICABLE MUST REMAIN WITHIN DIMENSIONS		SEE BOM TABLE		THIS DRAWING CONTAINS INFORMATION THAT IS PROPRIETARY TO MOLEX INCORPORATED AND SHOULD NOT BE USED WITHOUT WRITTEN PERMISSION			

20 19 18 17 16 15 14 13 12 11 10 9 8 7 6 5 4 3 2 1

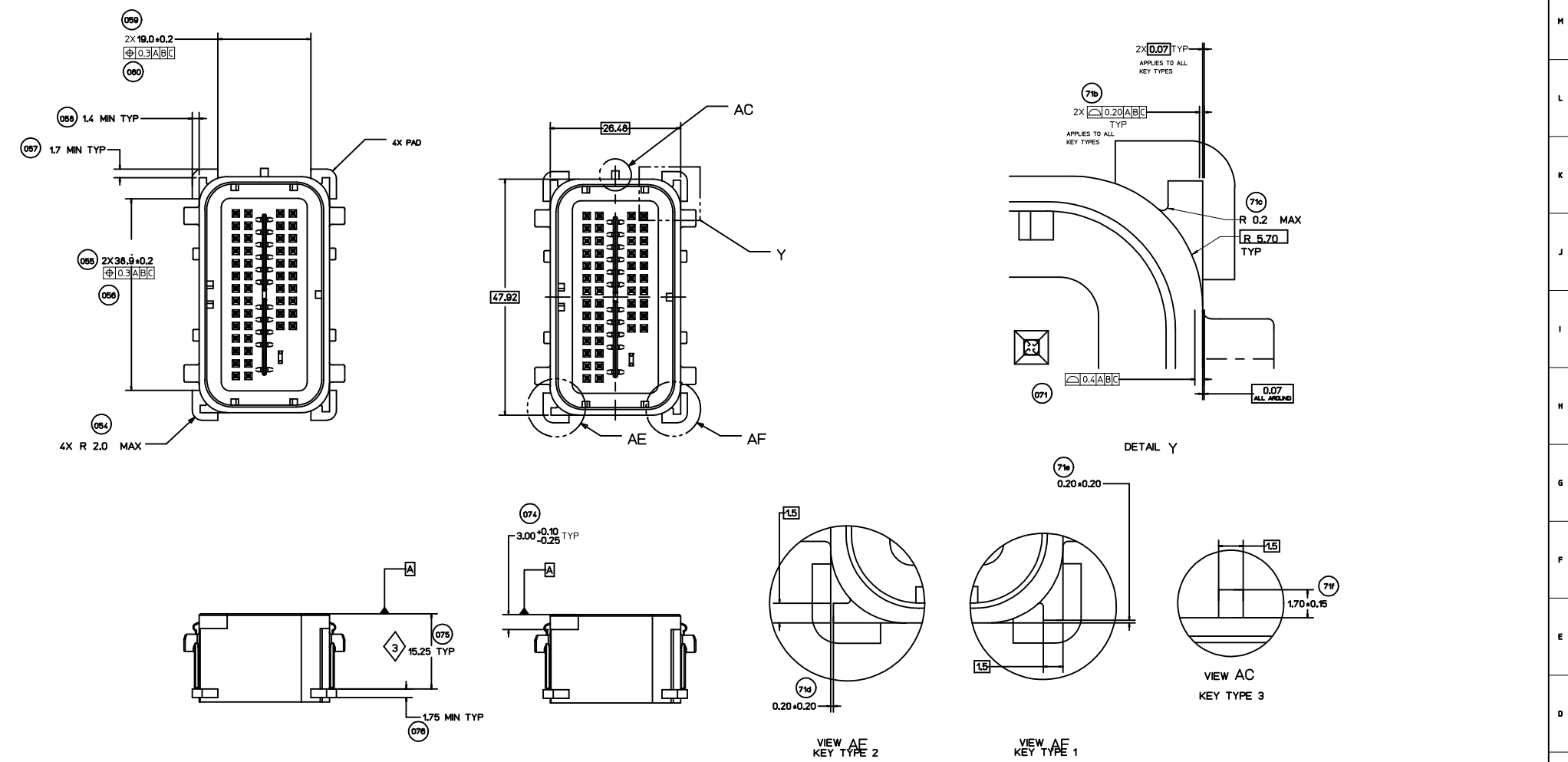

ENTER DESCRIPTION IEC NO: UAU2017-0870 DRAWN: ACHITALEA 2017/03/27 CHKD: APPR: VKOSHY 2017/03/29 REL:	QUALITY SYMBOLS	GENERAL TOLERANCES (UNLESS SPECIFIED)	DIMENSION STYLE	SCALE	DESIGN UNITS	THIRD ANGLE PROJECTION
	▽=0	mm INCH	MM ONLY	1:1	METRIC	
	▽=0	4 PLACES ± --- ± ---	DRAWN BY DATE			
	▽=0	3 PLACES ± --- ± ---	SKRAJENDRANA 2016/12/15			
	2 PLACES ± 0.13 ± ---	CHECKED BY DATE				TITLE ICD - MX123 18/49/56CKT INTERFACE CONNECTION DRW MOLEX
	1 PLACE ± 0.25 ± ---	VKOSHY 2016/12/15				
	0 PLACE ± --- ± ---	APPROVED BY DATE				molex MATERIAL NO. DOCUMENT NO. SHEET NO. SEE BOM TABLE SD-34576-0001 16 OF 22
	ANGULAR ± 1 °	VKOSHY 2017/03/03				
	DRAFT WHERE APPLICABLE MUST REMAIN WITHIN DIMENSIONS					

16 OF 22

20 19 18 17 16 15 14 13 12 11 10 9 8 7 6 5 4 3 2 1

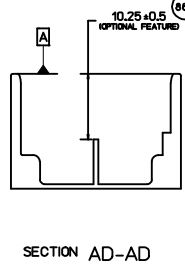
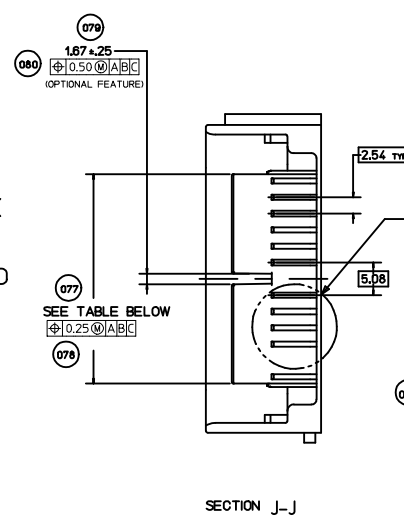
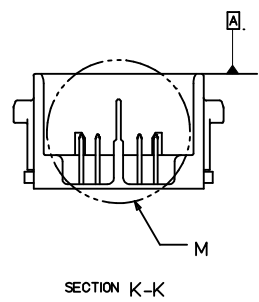
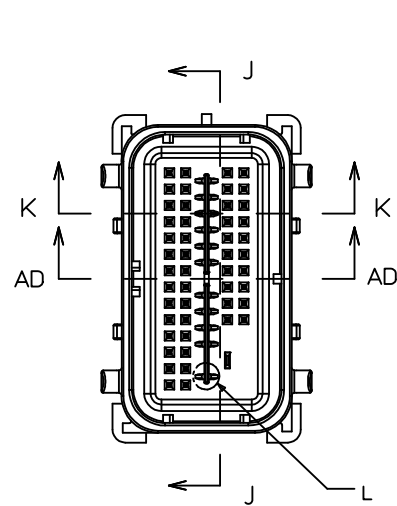

CKT	DIM (077)
49 / 56 CKT	32.80 +0.10/-0.80
18 CKT	10.04 +0.10/-0.80

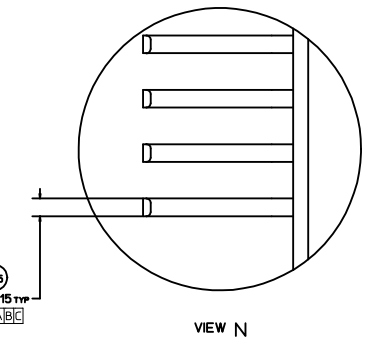
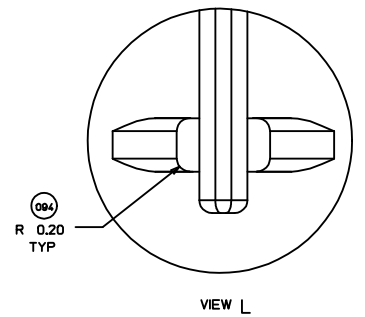
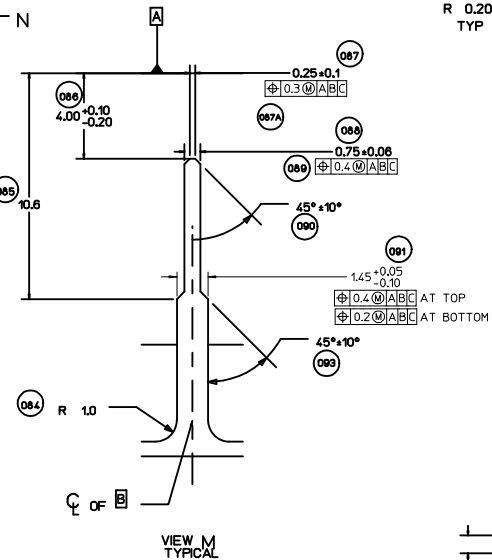

QUALITY SYMBOLS		GENERAL TOLERANCES (UNLESS SPECIFIED)		DIMENSION STYLE		SCALE	DESIGN UNITS	THIRD ANGLE PROJECTION	
SYMBOL	DESCRIPTION	mm	INCH	MM ONLY	INCH	1:1	METRIC		
$\nabla=0$	4 PLACES ± --- ± ---			DRAWN BY	DATE	TITLE			
$\nabla=0$	3 PLACES ± --- ± ---			SKRA JENDRANA	2016/12/15	ICD - MX123 18/49/56CKT			
$\nabla=0$	2 PLACES ± 0.13 ± ---			CHECKED BY	DATE	INTERFACE CONNECTION DRW			
$\nabla=0$	1 PLACE ± 0.25 ± ---			VKOSHY	2016/12/15	MOLEX			
$\nabla=0$	0 PLACE ± --- ± ---			APPROVED BY	DATE	molex			
				VKOSHY	2017/03/03	DOCUMENT NO. SD-34576-0001			
ANGULAR ± 1°		DRAFT WHERE APPLICABLE		MATERIAL NO.		SEE BOM TABLE		SHEET NO.	
DRAFT WHERE APPLICABLE		MUST REMAIN WITHIN DIMENSIONS		SIZE D		THIS DRAWING CONTAINS INFORMATION THAT IS PROPRIETARY TO MOLEX INCORPORATED AND SHOULD NOT BE USED WITHOUT WRITTEN PERMISSION		17 OF 22	

ib_frame_D_P_AM.T Rev. G 2012/01/11

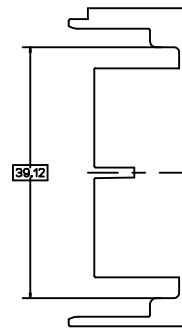
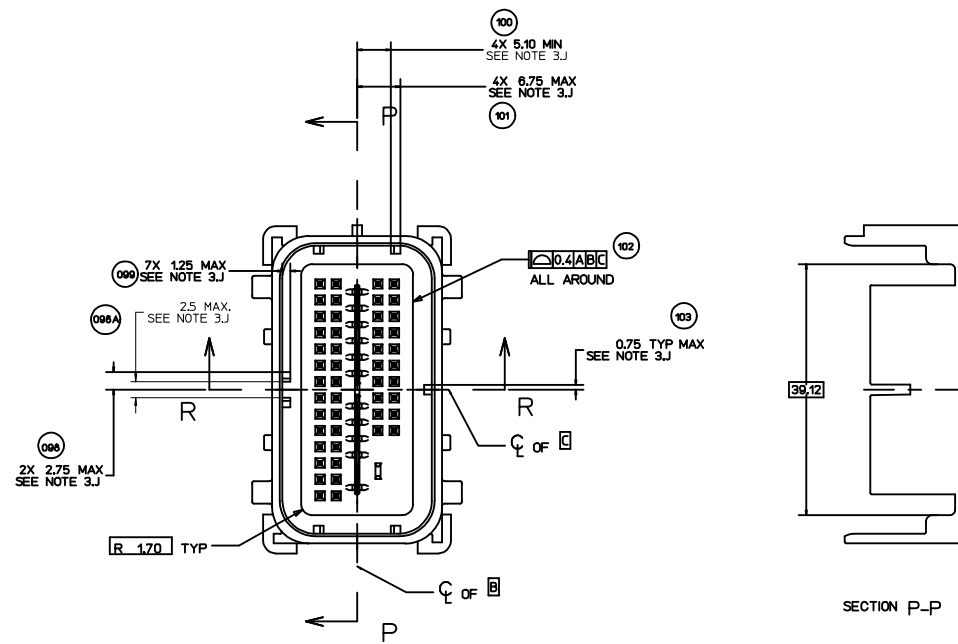

SECTION P-P

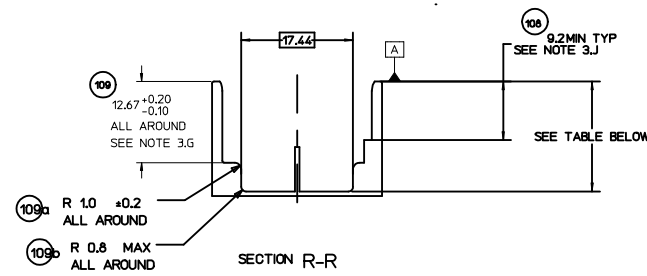

CKT	DIM 108
49 / 56 CKT	17.20 +0.20/-0.10
18 CKT	17.50 +0.20/-0.10

QUALITY SYMBOLS	GENERAL TOLERANCES (UNLESS SPECIFIED)		DIMENSION STYLE		SCALE	DESIGN UNITS	THIRD ANGLE PROJECTION
	mm	INCH	MM ONLY	INCH	1:1	METRIC	
▽=0	4 PLACES ±---	±---	DRAWN BY	DATE	TITLE		
▽=0	3 PLACES ±---	±---	SKRAJENDRANA	2016/12/15	ICD - MX123 18/49/56CKT		
▽=0	2 PLACES ±0.13	±---	CHECKED BY	DATE	INTERFACE CONNECTION DRW		
	1 PLACE ±0.25	±---	VKOSHY	2016/12/15	MOLEX		
	0 PLACE ±---	±---	APPROVED BY	DATE	molex		
			VKOSHY	2017/03/03	MATERIAL NO. DOCUMENT NO. SHEET NO.		
	ANGULAR ± 1 °		SEE BOM TABLE		SD-34576-0001		18 OF 22
	DRAFT WHERE APPLICABLE MUST REMAIN WITHIN DIMENSIONS		THIS DRAWING CONTAINS INFORMATION THAT IS PROPRIETARY TO MOLEX INCORPORATED AND SHOULD NOT BE USED WITHOUT WRITTEN PERMISSION				

ENTER DESCRIPTION
 IEC NO: UAU2017-0870
 DRW: NACHITALIA - 2017/03/17
 CHK: NACHITALIA
 APPR: VKOSHY
 2017/03/29

20 19 18 17 16 15 14 13 12 11 10 9 8 7 6 5 4 3 2 1

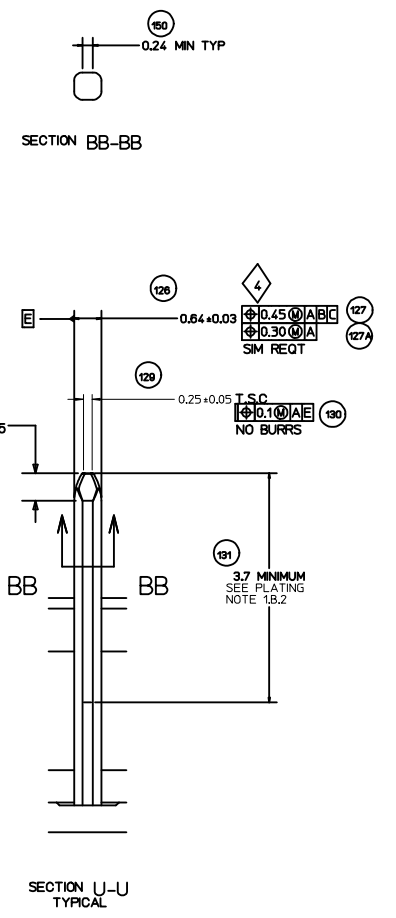
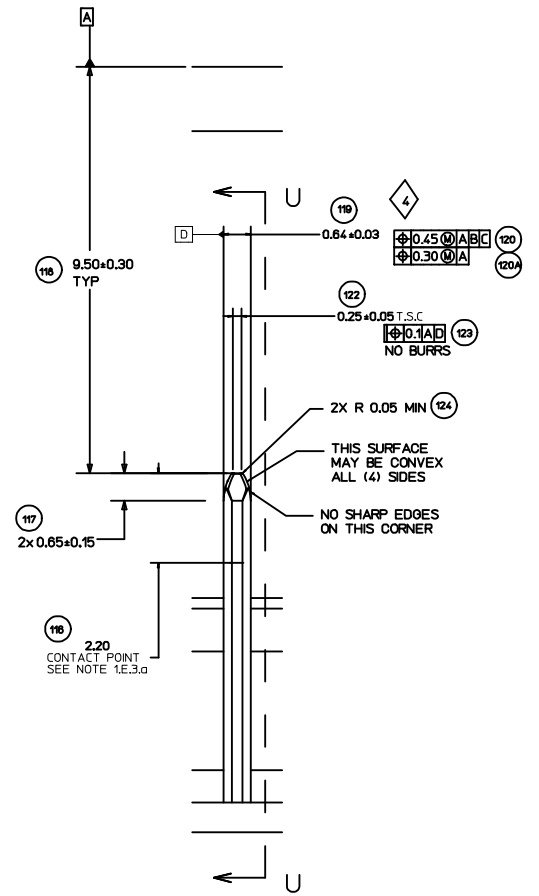
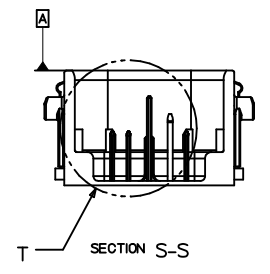
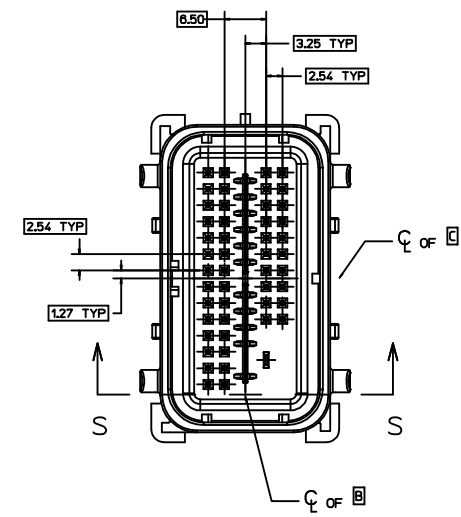

ENTER DESCRIPTION IEC NO: UAU2017-0870 DRW: ACHITALIA - 2807/03/17 CHKD: APPR: VKOSHY 2807/03/17	QUALITY SYMBOLS	GENERAL TOLERANCES (UNLESS SPECIFIED)	DIMENSION STYLE	SCALE	DESIGN UNITS	THIRD ANGLE PROJECTION
	▽=0	m/m INCH	MM ONLY	1:1	METRIC	
	▽=0	4 PLACES ± --- ± ---	DRAWN BY DATE			
	▽=0	3 PLACES ± --- ± ---	SKRA JENDRANA 2016/12/15			
	2 PLACES ± 0.13 ± ---	CHECKED BY DATE				TITLE
	1 PLACE ± 0.25 ± ---	VKOSHY 2016/12/15				ICD - MX123 18/49/56CKT
	0 PLACE ± --- ± ---	APPROVED BY DATE				INTERFACE CONNECTION DRW
		VKOSHY 2017/03/03				MOLEX
			MATERIAL NO.	DOCUMENT NO.		
			SEE BOM TABLE	SD-34576-0001		
			THIS DRAWING CONTAINS INFORMATION THAT IS PROPRIETARY TO MOLEX INCORPORATED AND SHOULD NOT BE USED WITHOUT WRITTEN PERMISSION			
						SHEET NO. 19 OF 22

19 18 17 16 15 14 13 12 11 10 9 8 7 6 5 4 3 2 1

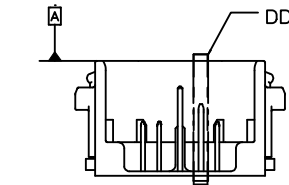
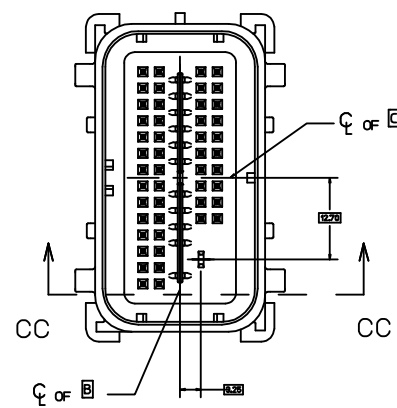

SECTION CC-CC

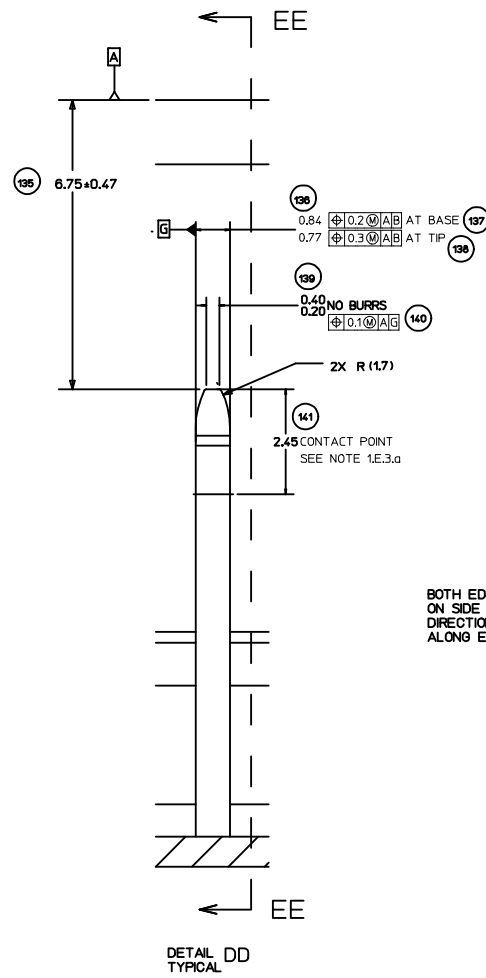

DETAIL DD TYPICAL

BOTH EDGES CONED ON SIDE OPPOSITE DIRECTION OF PUNCH ALONG ENTIRE LENGTH

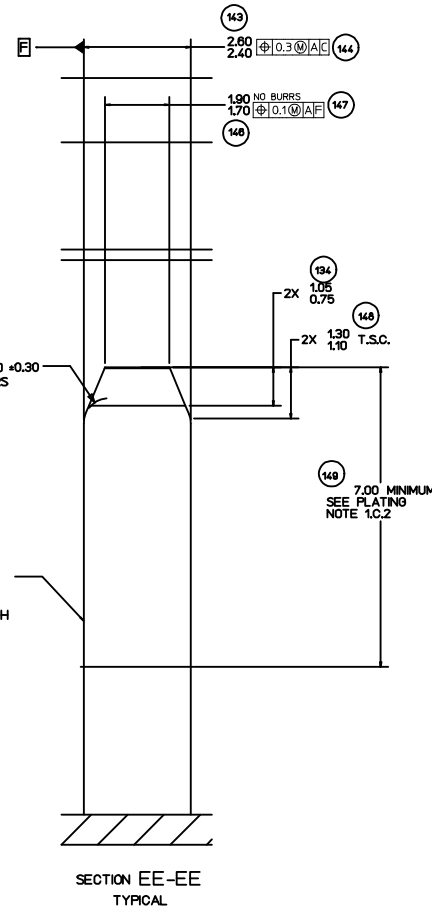

SECTION EE-EE TYPICAL

ENTER DESCRIPTION IEC NO: UAU2017-0870 DRAWN: CHITRALIA 2017/03/17 CHKD: APPR: VKOSHY 2017/03/29	QUALITY SYMBOLS	GENERAL TOLERANCES (UNLESS SPECIFIED)	DIMENSION STYLE	SCALE	DESIGN UNITS	THIRD ANGLE PROJECTION
	$\nabla=0$	mm INCH	MM ONLY	1:1	METRIC	
	$\nabla=0$	4 PLACES ± --- ± ---	DRAWN BY DATE	TITLE		
	$\nabla=0$	3 PLACES ± --- ± ---	SKRAJENDRANA 2016/12/15	ICD - MX123 18/49/56CKT		
$\nabla=0$	2 PLACES ± 0.13 ± ---	CHECKED BY DATE	INTERFACE CONNECTION DRW			
	1 PLACE ± 0.25 ± ---	VKOSHY 2016/12/15	MOLEX			
	0 PLACE ± --- ± ---	APPROVED BY DATE	molex			
		VKOSHY 2017/03/03	SD-34576-0001			
	ANGULAR ± 1 °	MATERIAL NO.	DOCUMENT NO.	SHEET NO.		
	DRAFT WHERE APPLICABLE MUST REMAIN WITHIN DIMENSIONS	SEE BOM TABLE	SD-34576-0001	20 OF 22		
		THIS DRAWING CONTAINS INFORMATION THAT IS PROPRIETARY TO MOLEX INCORPORATED AND SHOULD NOT BE USED WITHOUT WRITTEN PERMISSION				

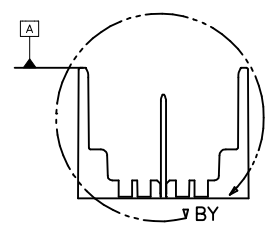
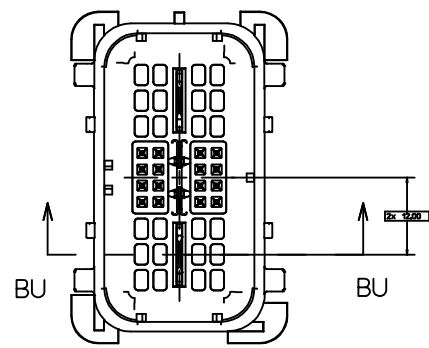

SECTION BU-BU

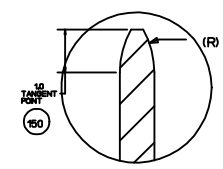

VIEW CA
SCALE 10:1

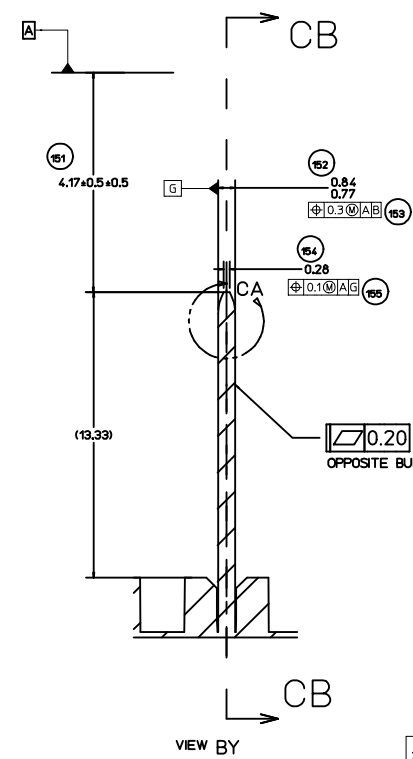

VIEW BY

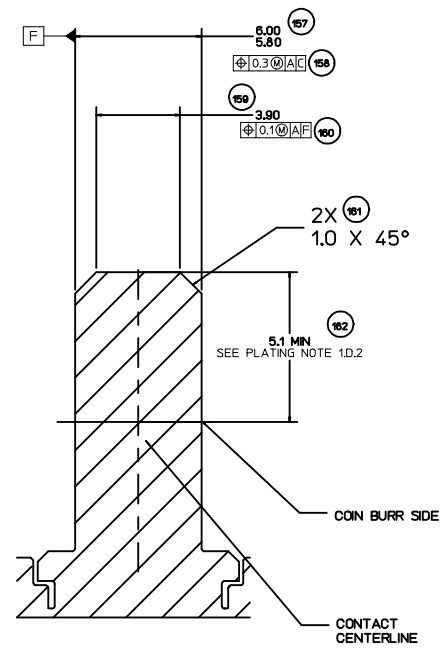

SECTION CB-CB

ENTER DESCRIPTION EC NO: UAU2017-0870 DRAWN: CHITRALIA CHKD: APPR: VKOSHY DATE: 2017/03/29	QUALITY SYMBOLS	GENERAL TOLERANCES (UNLESS SPECIFIED)	DIMENSION STYLE	SCALE	DESIGN UNITS	THIRD ANGLE PROJECTION
	▽=0	m/m INCH	MM ONLY	1:1	METRIC	
	▽=0	4 PLACES ± --- ± ---	DRAWN BY DATE			
	▽=0	3 PLACES ± --- ± ---	SKRA JENDRANA 2016/12/15			
		1 PLACE ± 0.25 ± ---	CHECKED BY DATE			
		0 PLACE ± --- ± ---	VKOSHY 2016/12/15			
		ANGULAR ± 1 °	APPROVED BY DATE			
		DRAFT WHERE APPLICABLE MUST REMAIN WITHIN DIMENSIONS	VKOSHY 2017/03/03			
			MATERIAL NO.	DOCUMENT NO.		
			SEE BOM TABLE	SD-34576-0001		
			THIS DRAWING CONTAINS INFORMATION THAT IS PROPRIETARY TO MOLEX INCORPORATED AND SHOULD NOT BE USED WITHOUT WRITTEN PERMISSION			
						SHEET NO. 21 OF 22

20 19 18 17 16 15 14 13 12 11 10 9 8 7 6 5 4 3 2 1

MOLEX MX64 RECEPTACLE TERMINAL INFORMATION						
ITEM	MOLEX P/N	WIRE SIZE MM2	TYPE	PLATING	REEL WIND DIRECTION	COMMENTS
1	34736-0025	0.35	ISO	SILVER	LEFT	
2	34736-0026	0.35	ISO	SILVER	RIGHT	
3	34736-0027	0.5 / 0.75	ISO	SILVER	LEFT	
4	34736-0028	0.5 / 0.75	ISO	SILVER	RIGHT	

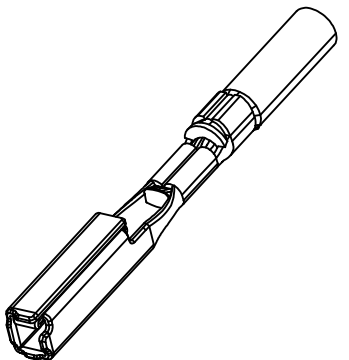
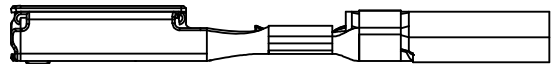

CAVITY PLUGS								
ITEM	MFG	MFG P/N	SIZE	COLOR	MFG DRAWING	PROD SPEC	APP SPEC	COMMENTS
1	MOLEX	34586-0001	0.64	NATURAL	SD-34586-001	PS-34566-0000	AS-34566-001	
2	YAZAKI	7158-3114-90	2.8	BLUE	7158-3114-90	YPES-11-04-062	YPES-15-299	

ITEM 1

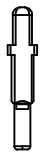
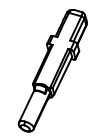

ITEM 2

ENTER DESCRIPTION IEC NO: UAU2017-0870 DRAWN: ACHITALIA 2017/03/27 CHKD: APPR: WKOSHY 2017/03/29 REV: A4	QUALITY SYMBOLS ∇=0 ∇=0 ∇=0	GENERAL TOLERANCES (UNLESS SPECIFIED) <table border="1"> <tr> <th></th> <th>mm</th> <th>INCH</th> </tr> <tr> <td>4 PLACES</td> <td>± 0.10</td> <td>± 0.004</td> </tr> <tr> <td>3 PLACES</td> <td>± 0.15</td> <td>± 0.006</td> </tr> <tr> <td>2 PLACES</td> <td>± 0.20</td> <td>± 0.008</td> </tr> <tr> <td>1 PLACE</td> <td>± 0.25</td> <td>± 0.010</td> </tr> <tr> <td>0 PLACE</td> <td>± 0.30</td> <td>± 0.012</td> </tr> </table>		mm	INCH	4 PLACES	± 0.10	± 0.004	3 PLACES	± 0.15	± 0.006	2 PLACES	± 0.20	± 0.008	1 PLACE	± 0.25	± 0.010	0 PLACE	± 0.30	± 0.012	DIMENSION STYLE MM ONLY	SCALE 1:1	DESIGN UNITS METRIC	THIRD ANGLE PROJECTION
		mm	INCH																					
	4 PLACES	± 0.10	± 0.004																					
	3 PLACES	± 0.15	± 0.006																					
2 PLACES	± 0.20	± 0.008																						
1 PLACE	± 0.25	± 0.010																						
0 PLACE	± 0.30	± 0.012																						
DRAFT WHERE APPLICABLE MUST REMAIN WITHIN DIMENSIONS		ANGULAR ± 1°	DRAWN BY: SKRA JENDRANA 2016/12/15 CHECKED BY: WKOSHY 2016/12/15 APPROVED BY: WKOSHY 2017/03/03	TITLE ICD - MX123 18/49/56CKT INTERFACE CONNECTION DRW MOLEX																				
SEE BOM TABLE			MATERIAL NO.	DOCUMENT NO. SD-34576-0001	SHEET NO. 22 OF 22																			
THIS DRAWING CONTAINS INFORMATION THAT IS PROPRIETARY TO MOLEX INCORPORATED AND SHOULD NOT BE USED WITHOUT WRITTEN PERMISSION																								

19 18 17 16 15 14 13 12 11 10 9 8 7 6 5 4 3 2 1

F
E
D
C
B
A

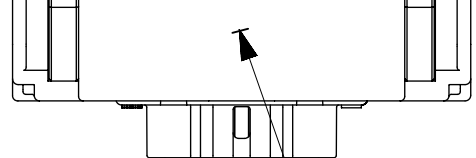

RECOMMENDED LOCATION
FOR NOTE 2D

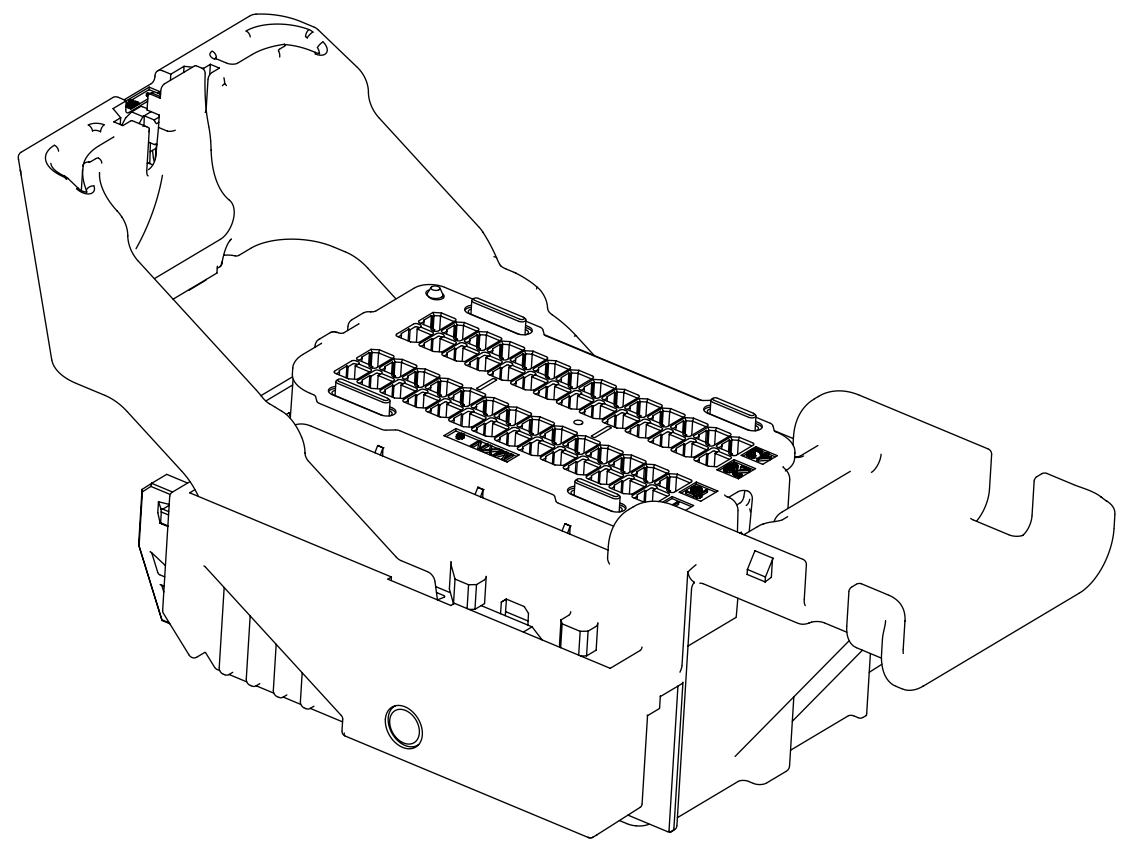
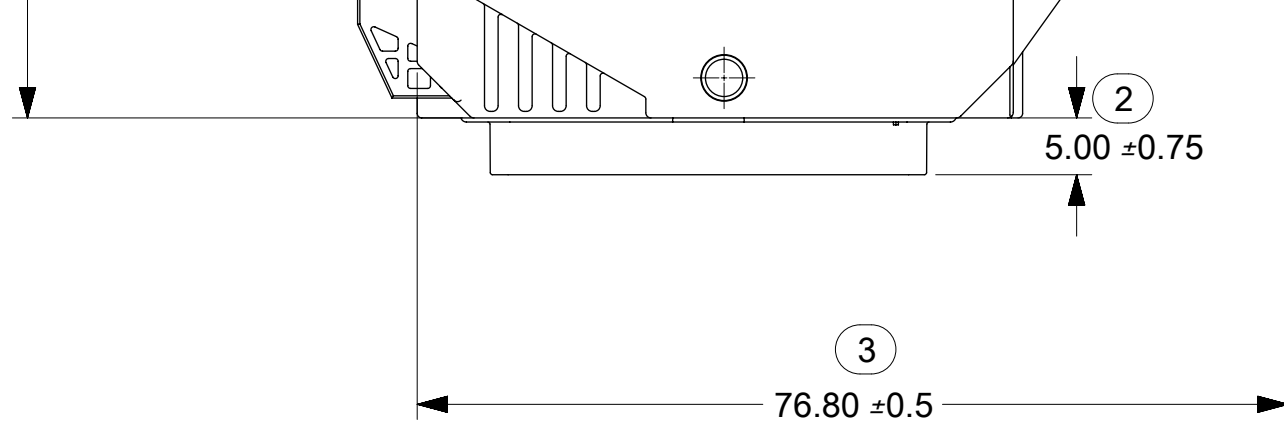

56 CKT
SCALE 1.5:1

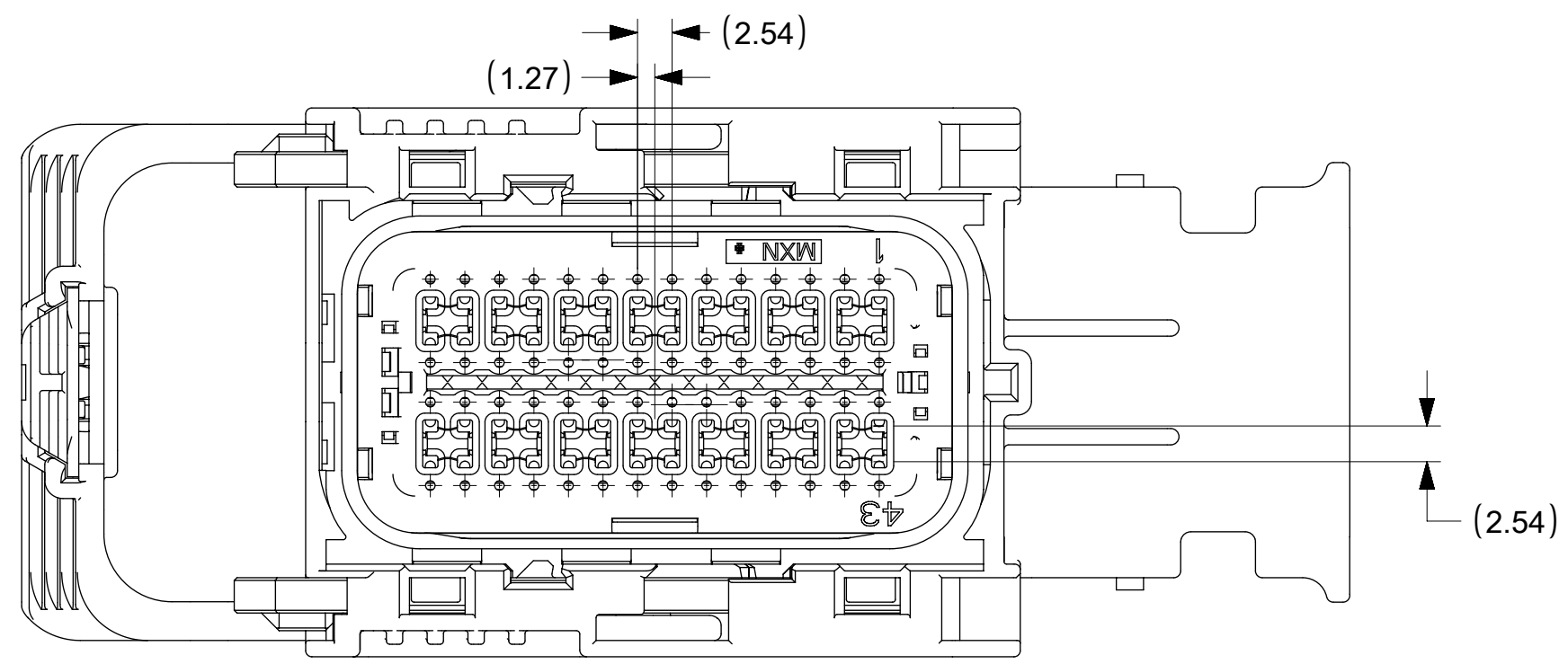

DOCUMENT STATUS	P1	RELEASE DATE	2018/05/28	14:32:56
-----------------	----	--------------	------------	----------

F
E
D
C
B
A

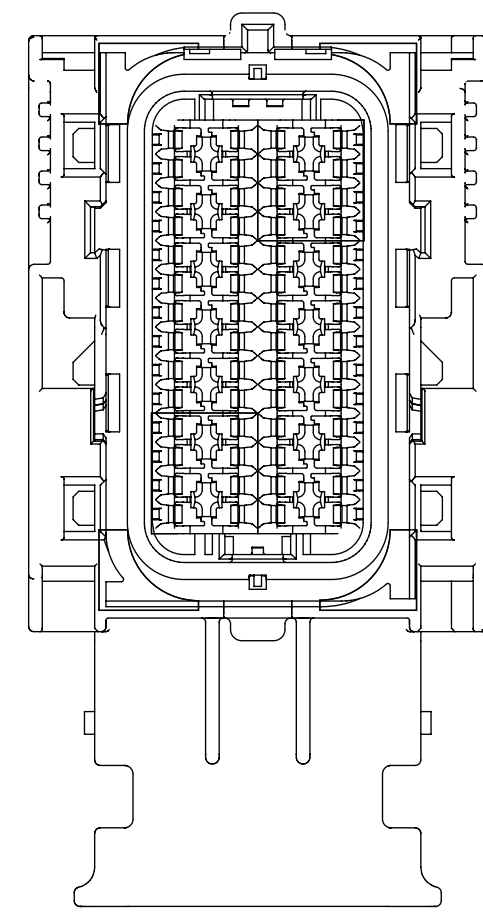
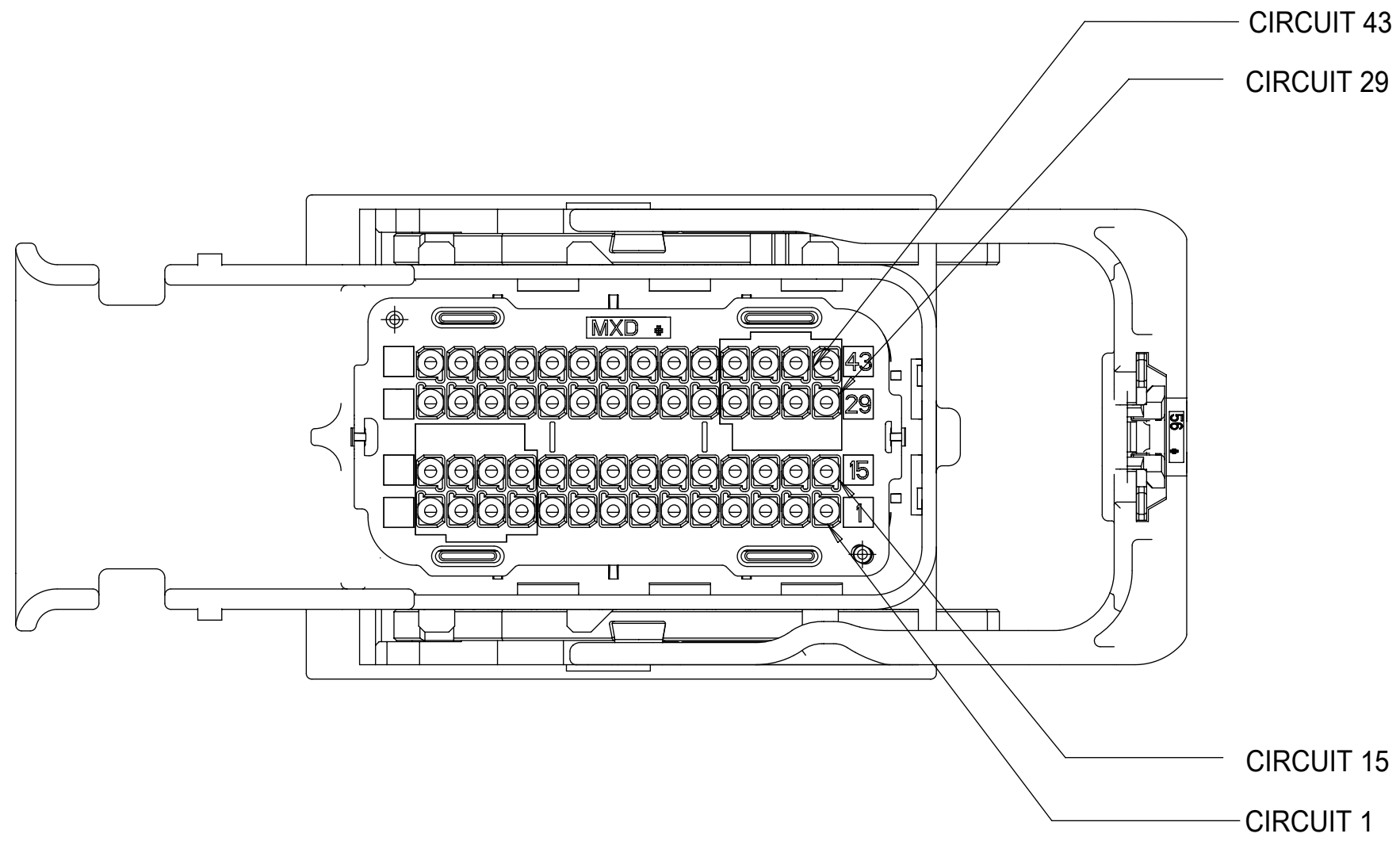

KEY G

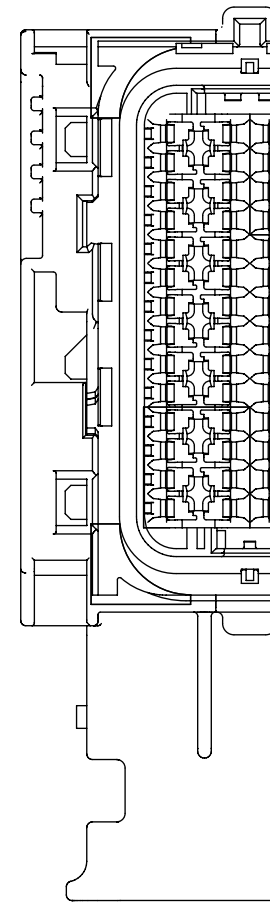

KEY

DOCUMENT STATUS	P1	RELEASE DATE	2018/05/28	14:32:56
-----------------	----	--------------	------------	----------

F
E
D
C
B
A

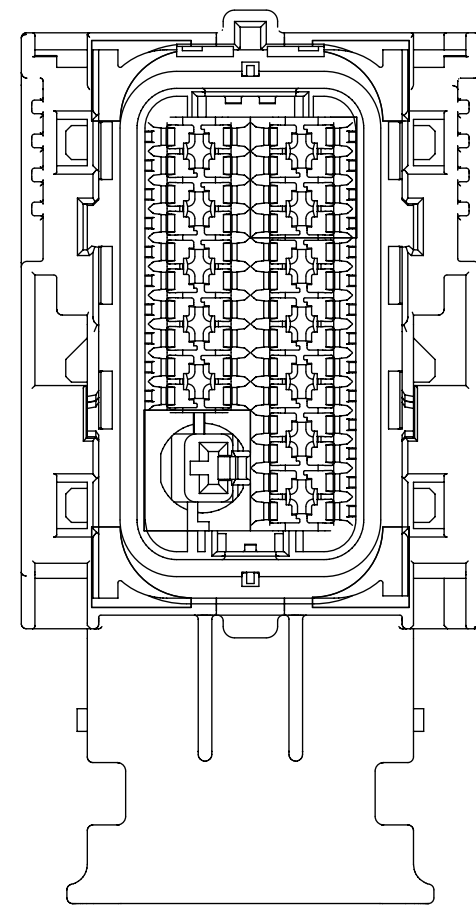
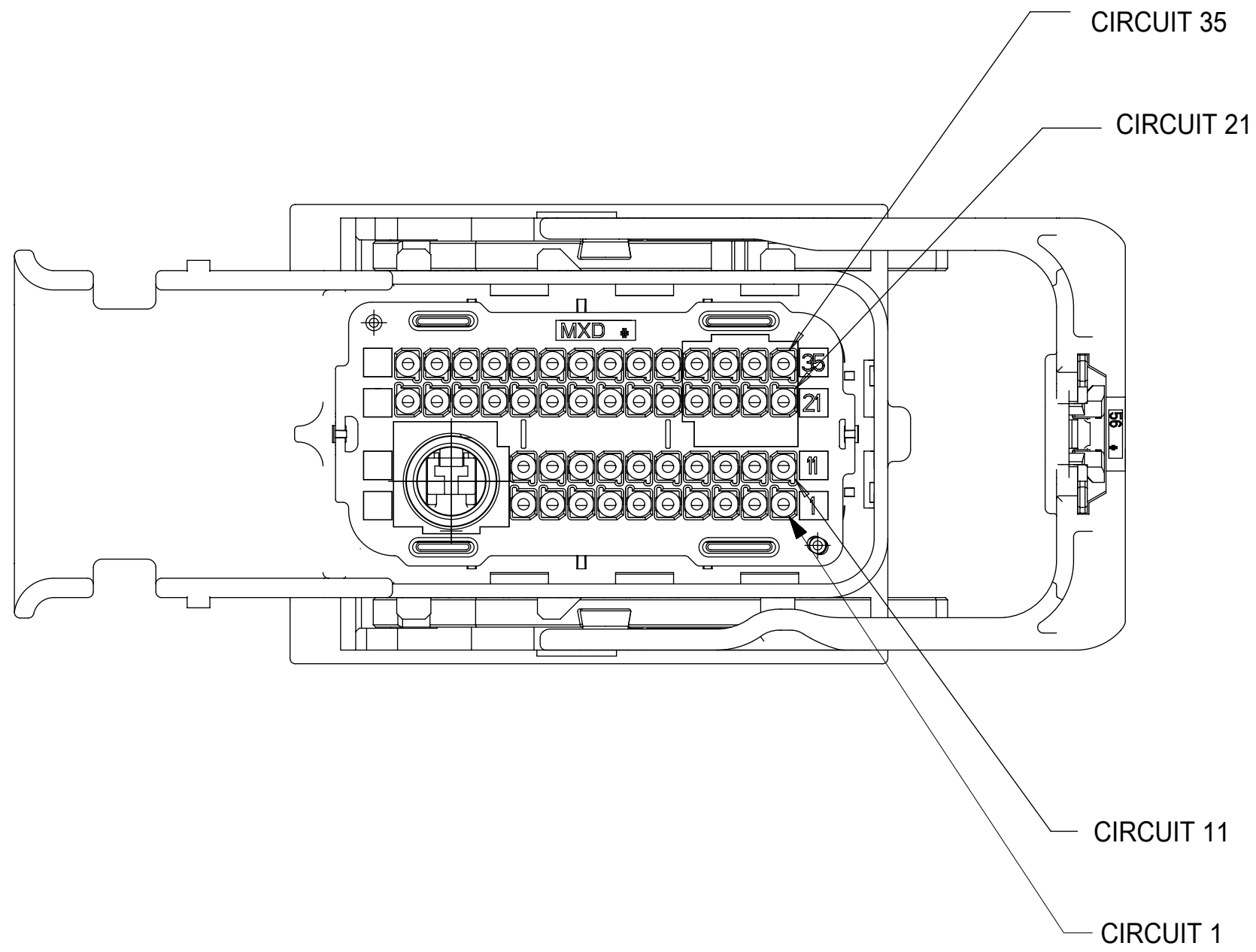

KEY A

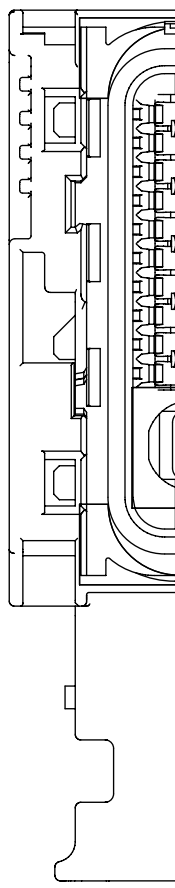

DOCUMENT STATUS	P1	RELEASE DATE	2018/05/28	14:32:56
-----------------	----	--------------	------------	----------

F
E
D
C
B
A

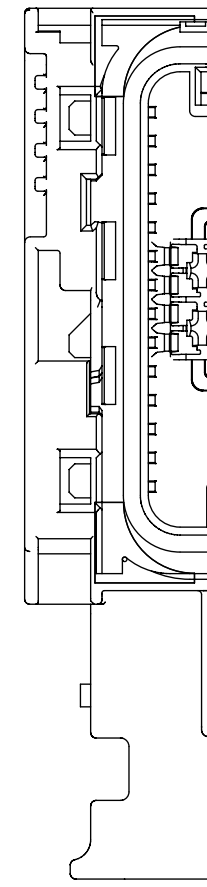
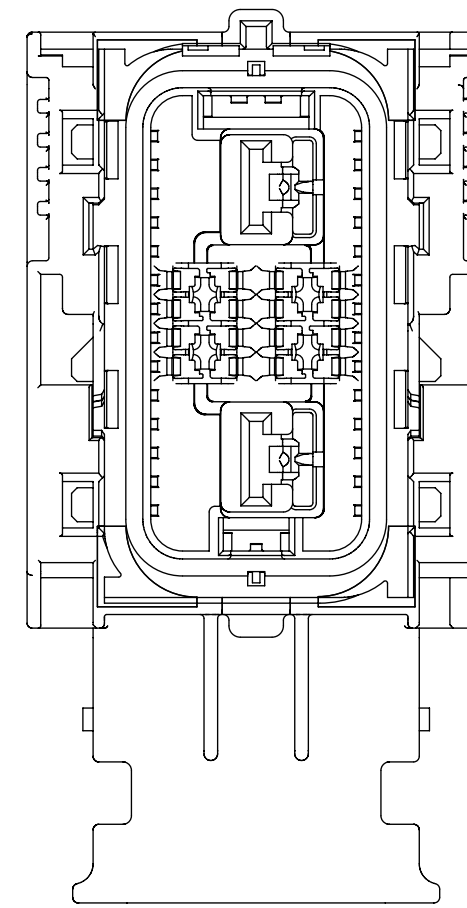
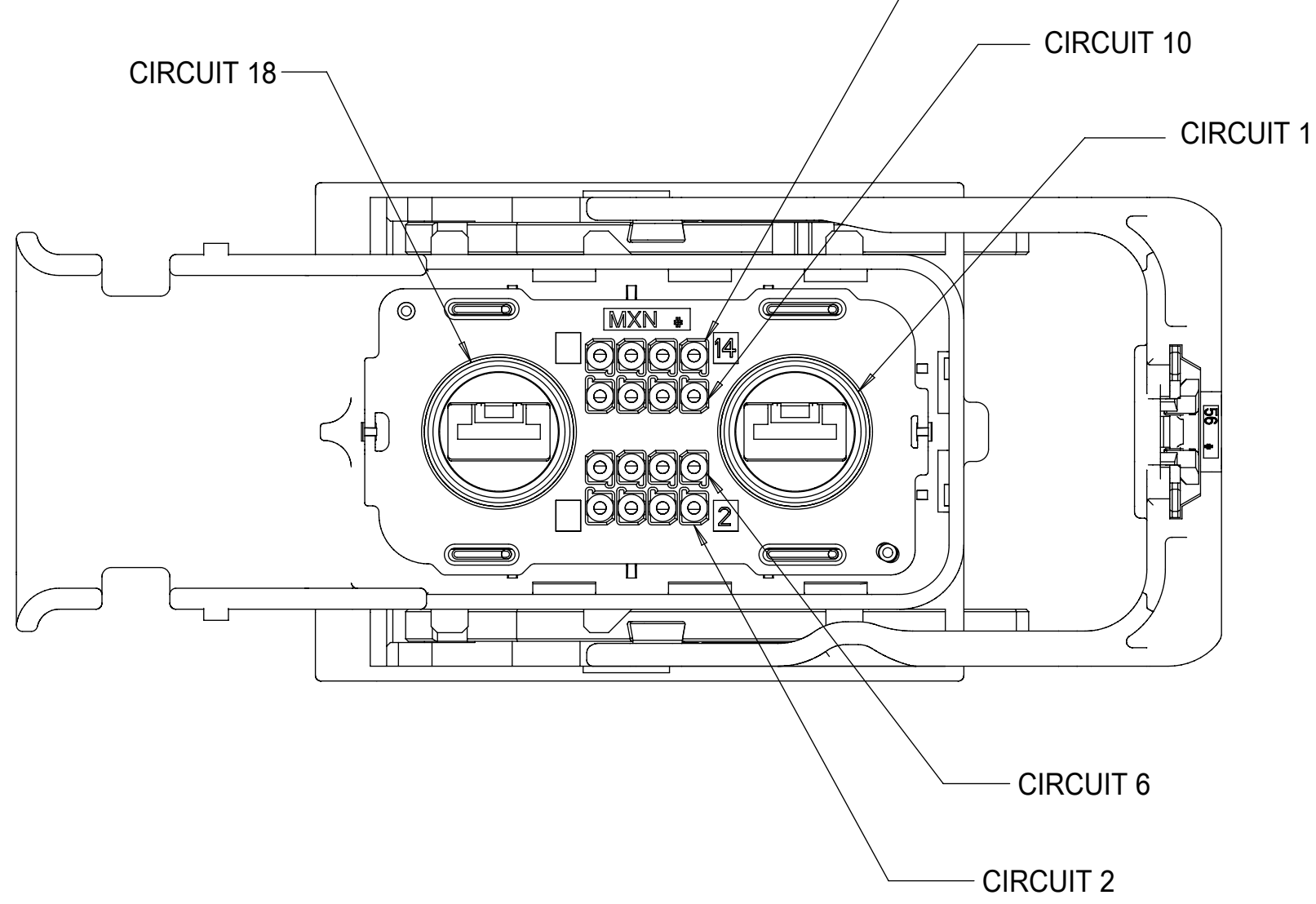

DOCUMENT STATUS	P1	RELEASE DATE	2018/05/28	14:32:56
-----------------	----	--------------	------------	----------

XXXXX- S
SERIES #
34090
34332
34335

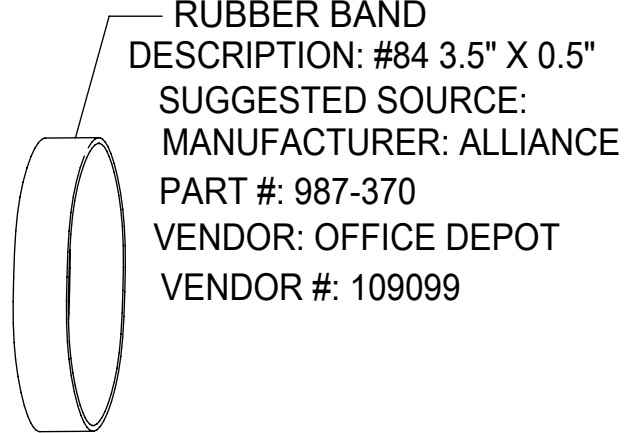

RUBBER BAND
 DESCRIPTION: #84 3.5" X 0.5"
 SUGGESTED SOURCE:
 MANUFACTURER: ALLIANCE
 PART #: 987-370
 VENDOR: OFFICE DEPOT
 VENDOR #: 109099

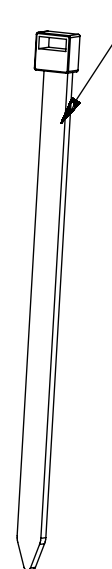

SUGGESTED SOURCE:
 MANUFACTURER: THOMAS & BETTS
 PART #: TY25M
 VENDOR: CRESENT ELEC
 VENDOR #: 104144



MX64 WIRE ASSY LOOPED
 MATERIAL #: SEE HRNS ASSY TABLE

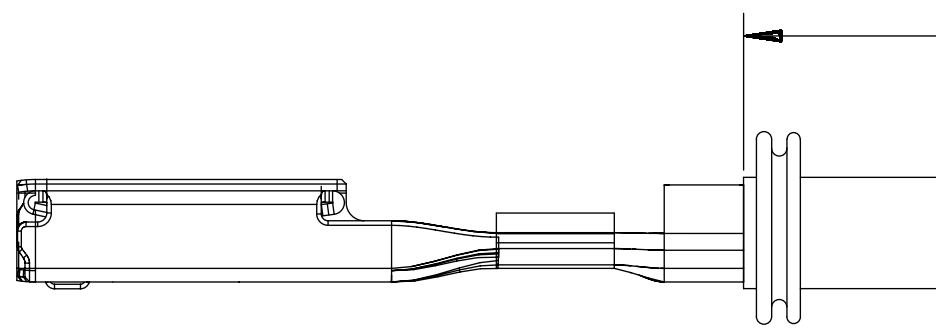

6.3mm
 M

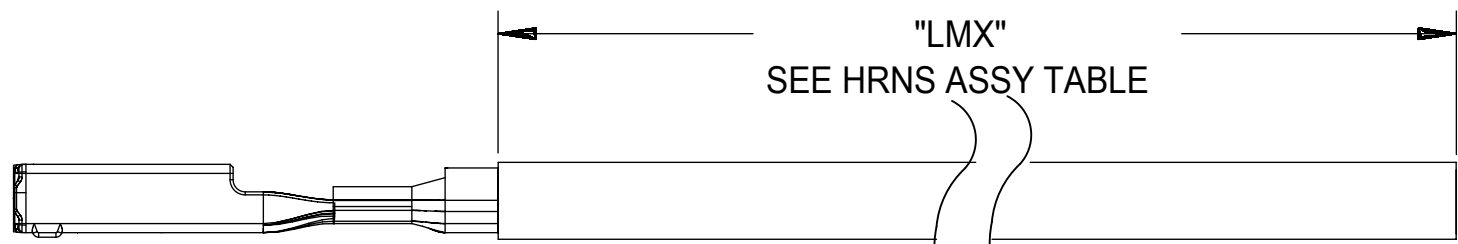

MX64 WIRE ASSY PIGTAIL
 MATERIAL #: SEE HRNS ASSY TABLE

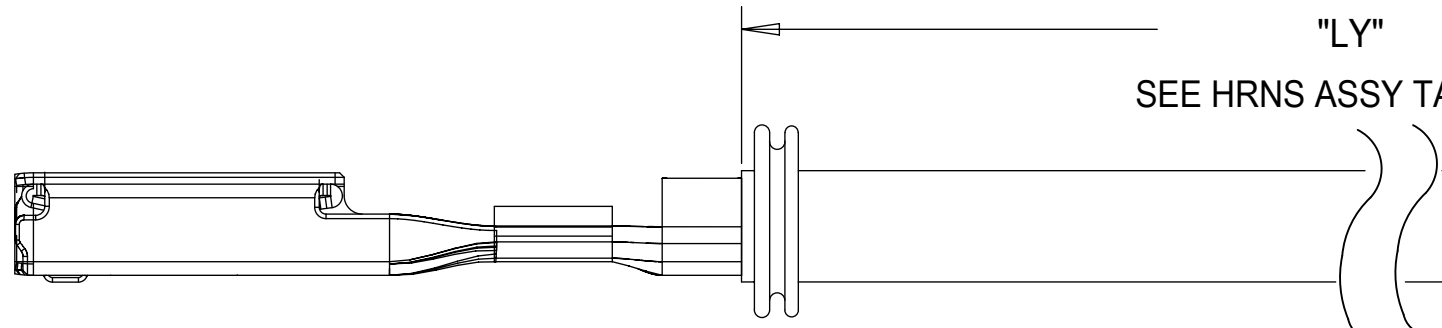

6.3mm FCI APEX SEALED FEMALE LC
 MATERIAL #: SEE HRNS ASSY TA

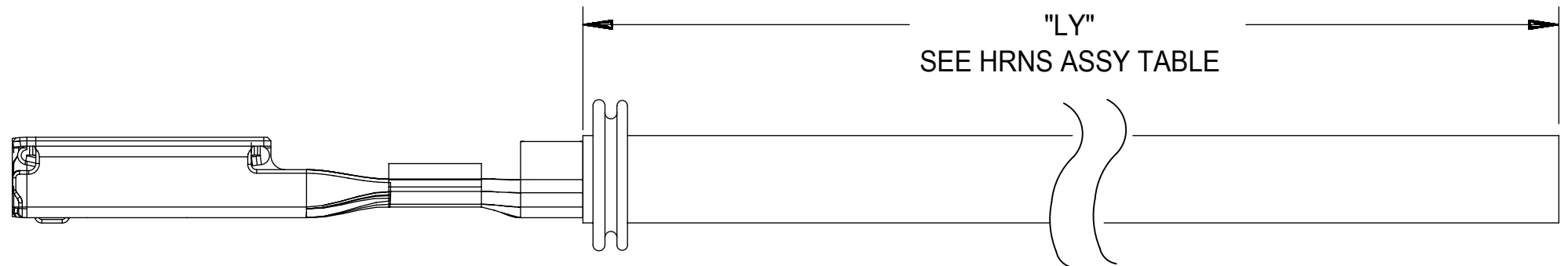

2.8mm YESC SEALED FEMALE PIGTAIL ASSY
 MATERIAL #: SEE HRNS ASSY TABLE

DOCUMENT STATUS	P1	RELEASE DATE	2018/05/28	14:32:56
-----------------	----	--------------	------------	----------

F
E
D
C
B
A

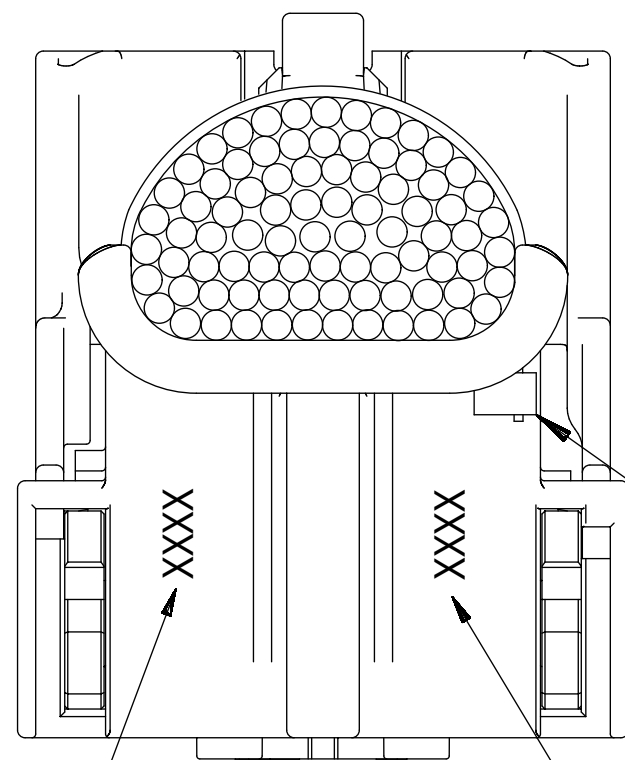
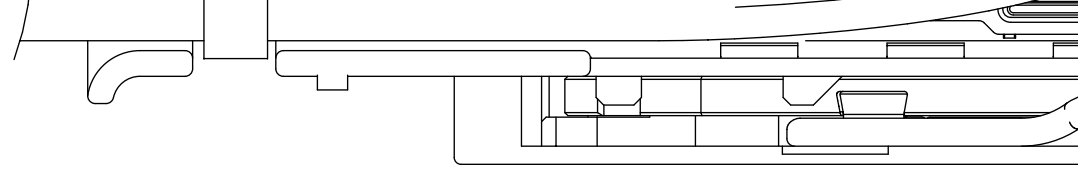

HAND ETCH
JULIAN DATE
WHEN PRESSURE
TESTED

HAND ETCH
JULIAN DATE
OF MFG

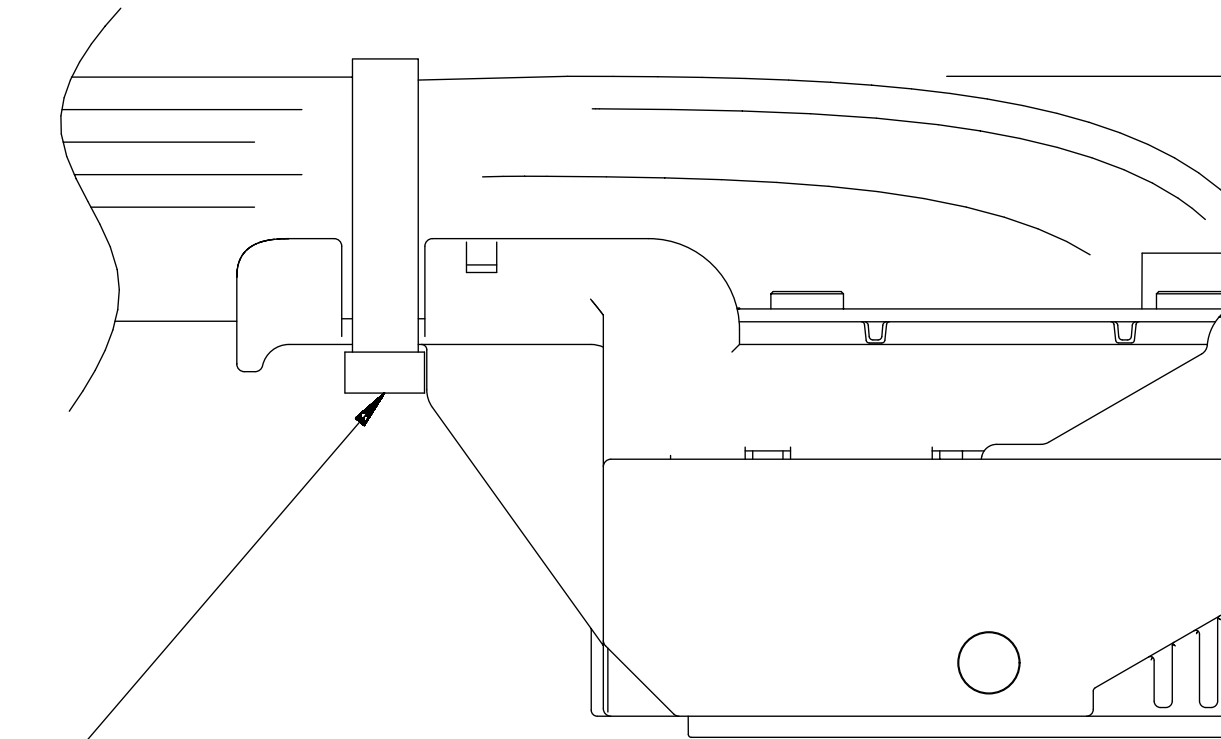

TY-RAP SHOWN IN
PROPER ORIENTATION

DOCUMENT STATUS	P1	RELEASE DATE	2018/05/28	14:32:56
-----------------	----	--------------	------------	----------

DESCRIPTION: #34090 X 0.9
 SUGGESTED SOURCE:
 MANUFACTURER: ALLIANCE
 PART #: 987-370
 VENDOR: OFFICE DEPOT
 VENDOR #: 109099

PART #: TY25M
 VENDOR: CRESENT ELEC
 VENDOR #: 104144

SERIES #
34090
34332
34335



MX64 WIRE ASSY LOOPED
 MATERIAL #: SEE HRNS ASSY TABLE

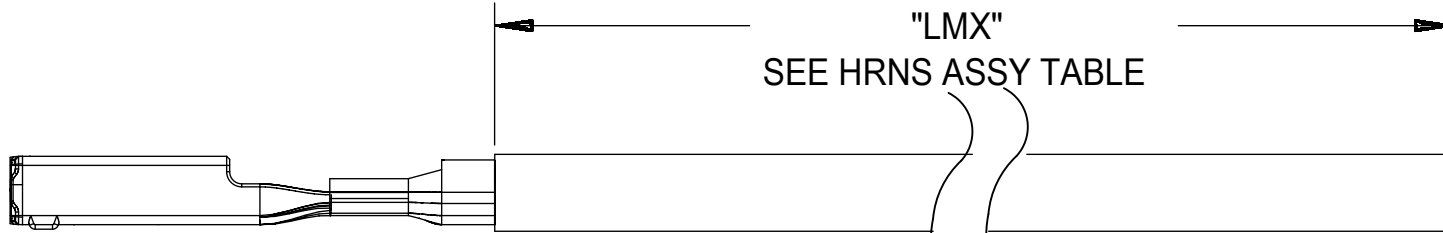

MX64 WIRE ASSY PIGTAIL
 MATERIAL #: SEE HRNS ASSY TABLE

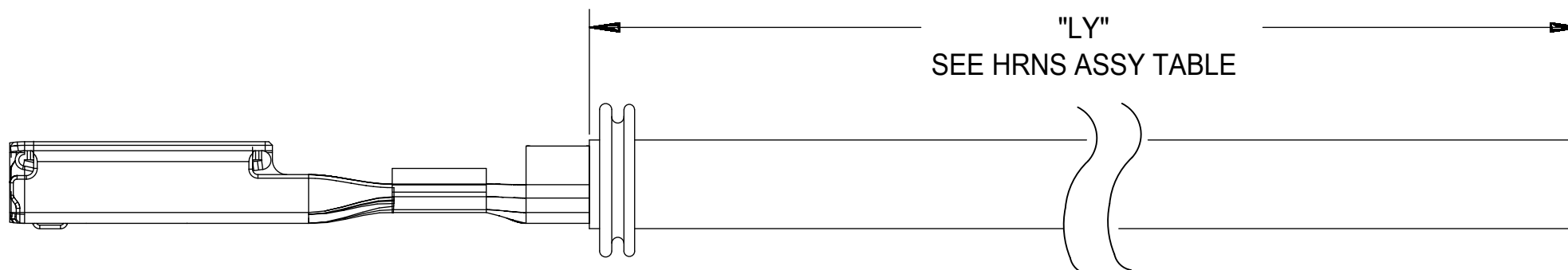

2.8mm YESC SEALED FEMALE PIGTAIL ASSY
 MATERIAL #: SEE HRNS ASSY TABLE

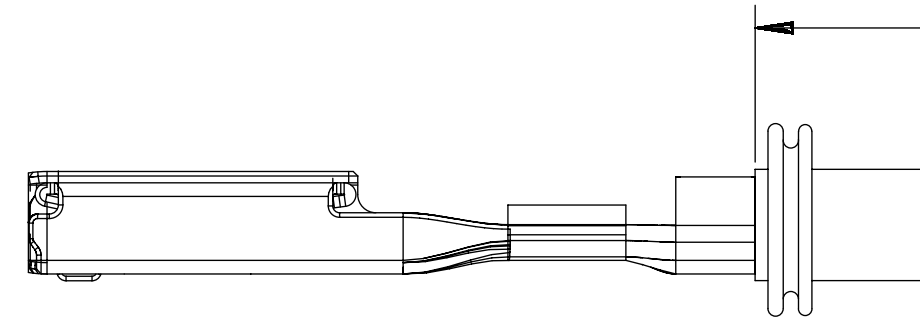

6.3

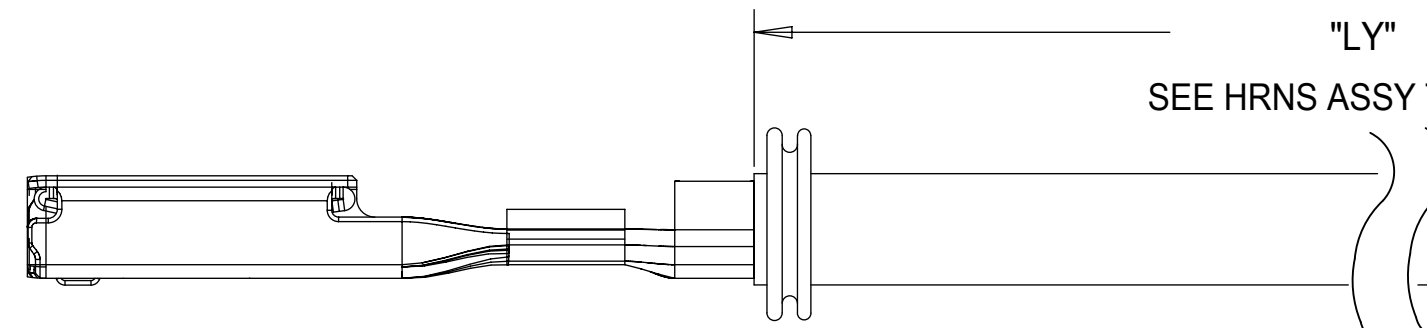

6.3mm FCI APEX SEALED FEMALE L
 MATERIAL #: SEE HRNS ASSY T

DOCUMENT STATUS	P1	RELEASE DATE	2018/05/28	14:32:56
-----------------	----	--------------	------------	----------

F
E
D
C
B
A

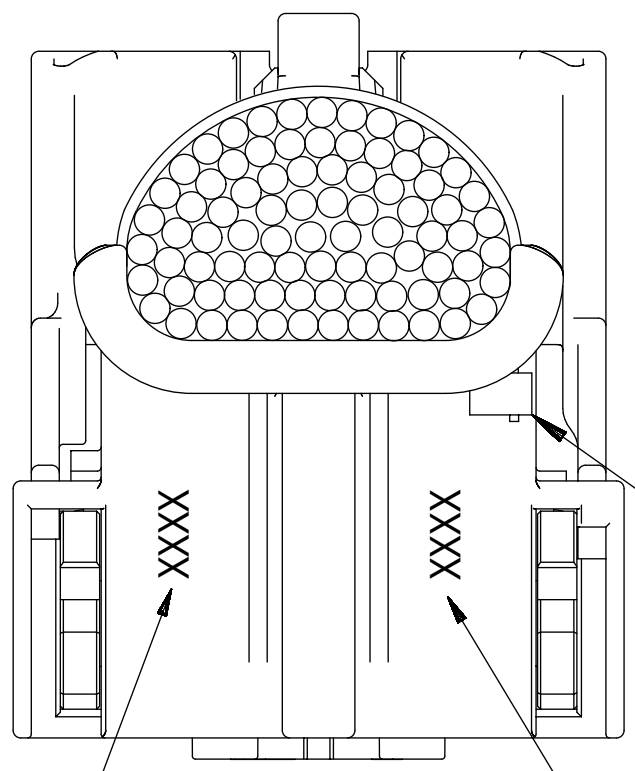
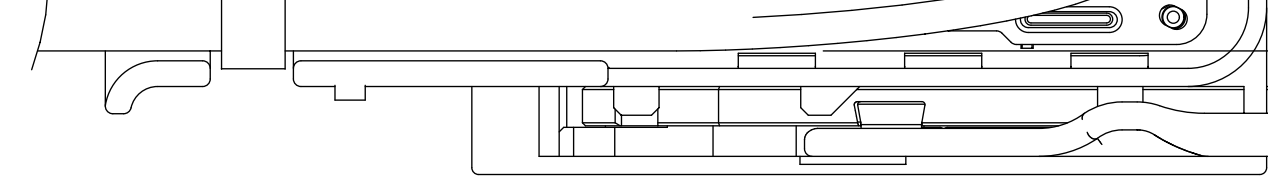

HAND ETCH
JULIAN DATE
WHEN PRESSURE
TESTED

HAND ETCH
JULIAN DATE
OF MFG

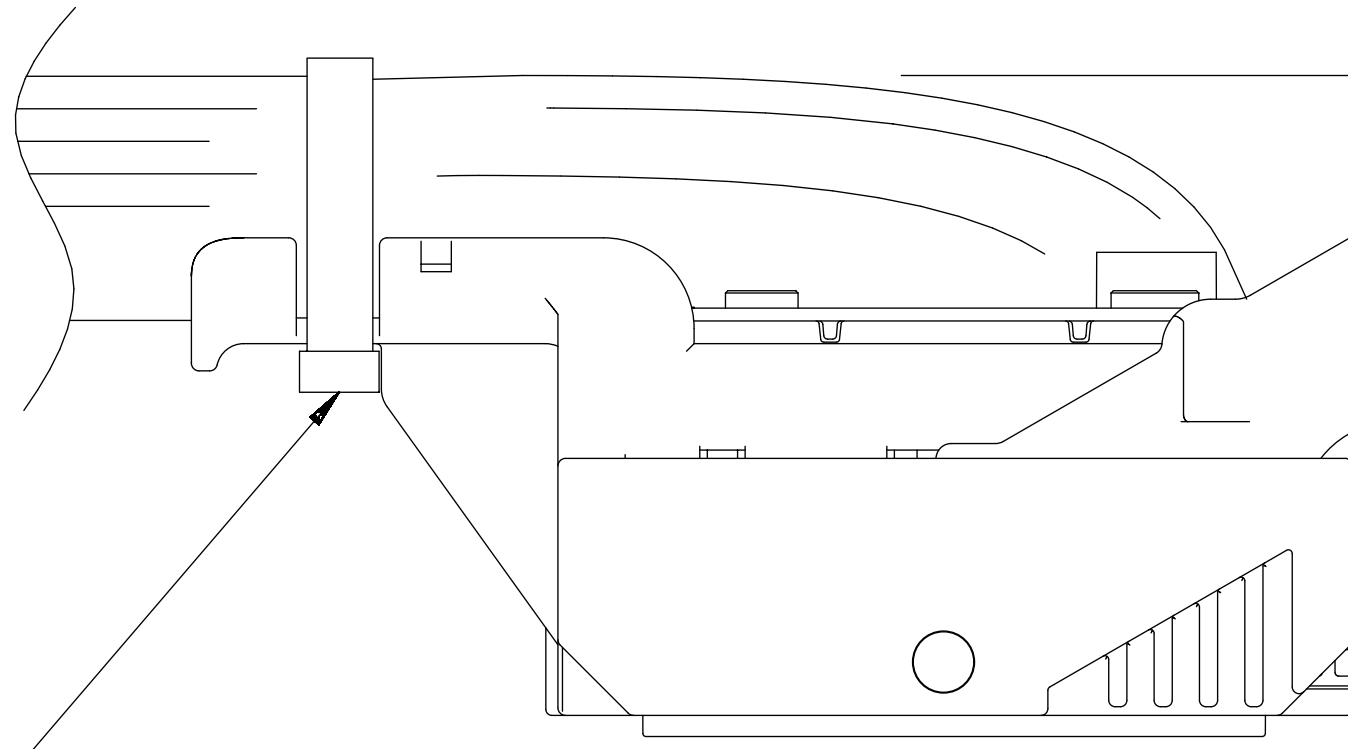

TY-RAP SHOWN IN
PROPER ORIENTATION

DOCUMENT STATUS	P1	RELEASE DATE	2018/05/28	14:32:56
-----------------	----	--------------	------------	----------



RUBBER BAND
 DESCRIPTION: #84 3.5" X 0.5"
 SUGGESTED SOURCE:
 MANUFACTURER: ALLIANCE
 PART #: 987-370
 VENDOR: OFFICE DEPOT
 VENDOR #: 109099



TY-RAP
 DESCRIPTION: SIZE TY25 CABLE TIE
 SUGGESTED SOURCE:
 MANUFACTURER: THOMAS & BETTS
 PART #: TY25M
 VENDOR: CRESENT ELEC
 VENDOR #: 104144

HRNS ASSY

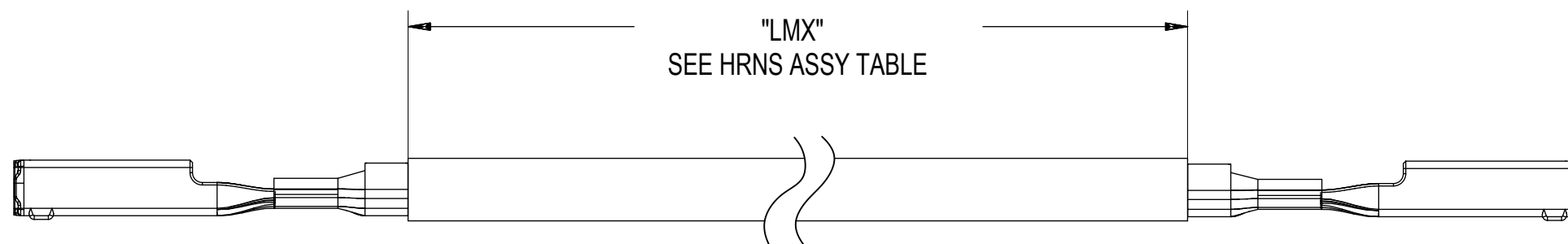

"LMX"
 SEE HRNS ASSY TABLE

MX64 WIRE ASSY LOOPED
 MATERIAL #: SEE HRNS ASSY TABLE

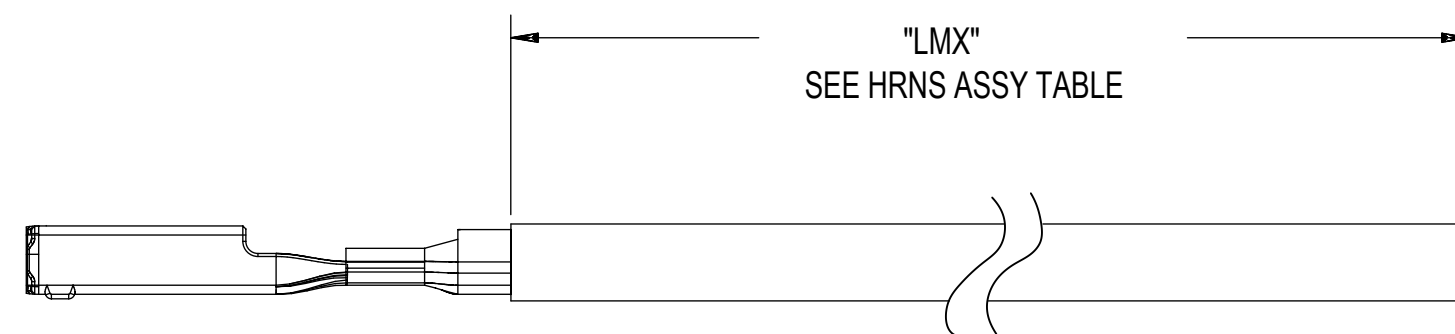

"LMX"
 SEE HRNS ASSY TABLE

MX64 WIRE ASSY PIGTAIL
 MATERIAL #: SEE HRNS ASSY TABLE

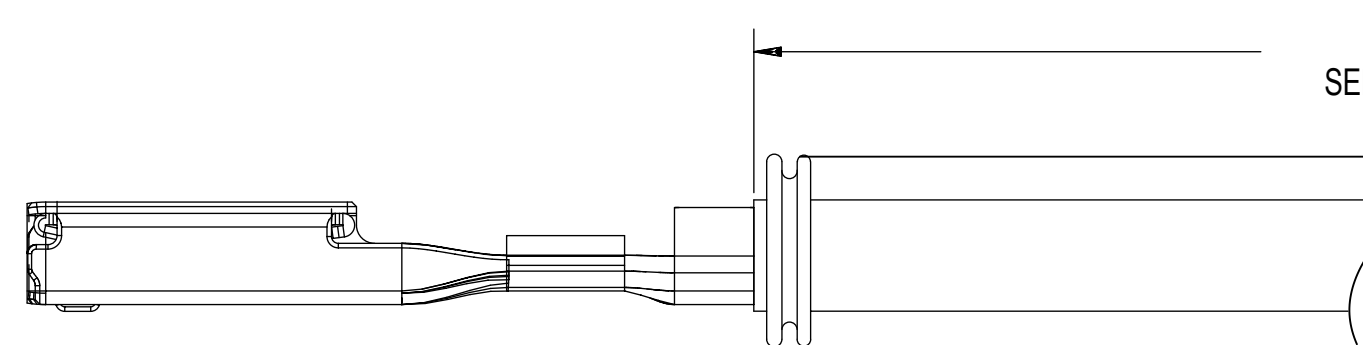

2.8mm YESC SEALED FEMALE
 MATERIAL #: SEE HRNS ASSY TABLE

DOCUMENT STATUS	P1	RELEASE DATE	2018/05/28	14:32:56
-----------------	----	--------------	------------	----------

X-ON Electronics

Largest Supplier of Electrical and Electronic Components

Click to view similar products for [Automotive Connectors](#) category:

Click to view products by [Molex](#) manufacturer:

Other Similar products are found below :

[003-018-000](#) [60403001](#) [60993906-B](#) [M902-2131](#) [M902-2161](#) [72.330.1035.1](#) [73.353.4028.0](#) [F119300-B](#) [F166900](#) [F258300-B](#) [F358300-B](#)
[F407400](#) [F444110](#) [F487000](#) [F509500B-B](#) [827153-1](#) [8N1515-32-24P](#) [9-1326729-8](#) [925474-1](#) [928905-1](#) [964562-4](#) [968782-1](#) [GT17SA-8DS-](#)
[HU](#) [98891-1012](#) [98947-1016](#) [12004147](#) [12004475-L](#) [12010290](#) [12010309-B](#) [12015454](#) [12020219-B](#) [12020308](#) [12041318-B](#) [12052466](#)
[12059125](#) [12064869](#) [12004327-B](#) [12010503-B](#) [12015308](#) [12015384](#) [12015909](#) [1-21030-1](#) [12041254](#) [12041318](#) [12047946-B](#) [12047957](#)
[12047957-L](#) [12059473](#) [12066261](#) [12110546](#)