

REF. -50 OPTION,
CLAMP WASHER SCREW
(WHERE APPLICABLE)

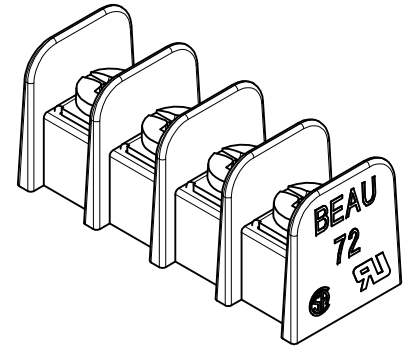

4 CIRCUIT SHOWN

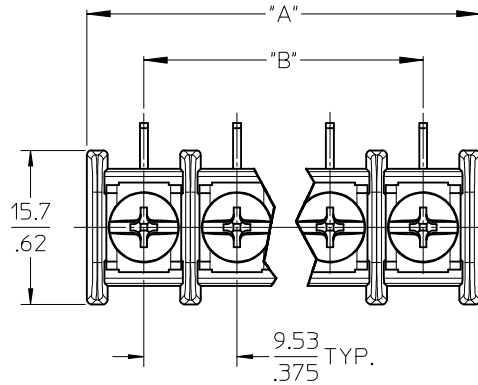
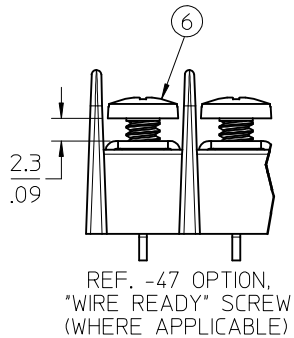

REF. -47 OPTION,
"WIRE READY" SCREW
(WHERE APPLICABLE)

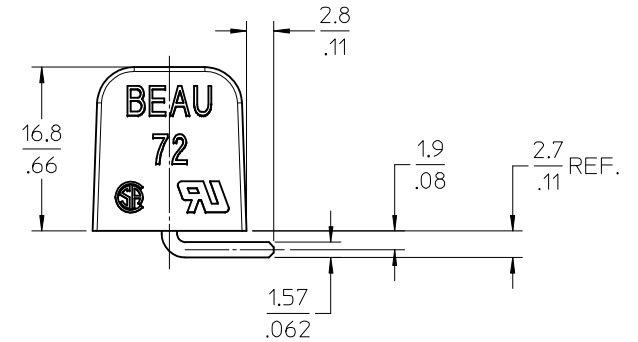
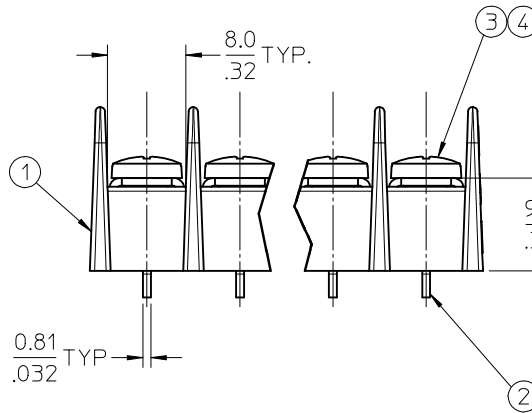

NOTES:

1. MATERIAL: SEE TABLE
2. FINISHES: SEE TABLE
3. "XX" REFERS TO THE QUANTITY OF CIRCUITS.
4. UL FILE# E48521, SEE SHEET 2.
5. CSA FILE# 025562, SEE SHEET 2.
6. INSULATOR IS UL 94 V-0
7. ALL COMPONENTS ARE ROHS COMPLIANT.

6	XX	SCREW #6-32 BHD, PH-SL, WRDY (-47 OPT)	STEEL	ZN, CLEAR CHROMATE	FILE SAVE CHG ONLY EC NO: WNA2010-0237 DT: DRW:NYORK 2009/10/01 CHKD:DTITUS 2009/10/02 APPR:DTITUS 2009/10/05 REV DESCRIPTION	QUALITY SYMBOLS ▽=0 ▽=0	GENERAL TOLERANCES (UNLESS SPECIFIED)		DIMENSION STYLE MM/IN		SCALE 2:1	DESIGN UNITS INCH	THIRD ANGLE PROJECTION
5	XX	SCREW&WASHER #6-32 PAN, PH-SL (-50 OPT)	STEEL	ZN, CLEAR CHROMATE			4 PLACES ± --- ± ---	INCH	DRAWN BY C. YORK	DATE 2006/02/08	TITLE 9.53/.375 SR BTS ASY, PC RA, NO MTG		
4	XX	SCREW #6-32 BHD, PHIL-SLOT (-49 OPT)	BRASS	NICKEL PLATE			3 PLACES ± --- ± .005		CHECKED BY RDEROSS	DATE 2006/02/08			
3	XX	SCREW #6-32 BHD, PHIL-SLOT (STD.)	STEEL	ZN, CLEAR CHROMATE			2 PLACES ± 0.13 ± .01		APPROVED BY DTITUS	DATE 2009/10/02	MATERIAL NO. SD-38721-001		
2	XX	TERMINAL, WW	BRASS	TIN PLATE			1 PLACE ± 0.25 ± ---		MATERIAL NO. SEE CHART		DOCUMENT NO. SD-38721-001		SHEET NO. 1 OF 2
1	1	INSULATOR, SR, NO MTG.	PBT, 30% GF	BLACK			ANGULAR ± 2 °		THIS DRAWING CONTAINS INFORMATION THAT IS PROPRIETARY TO MOLEX INCORPORATED AND SHOULD NOT BE USED WITHOUT WRITTEN PERMISSION				
ITEM	QTY.	DESCRIPTION	MATERIAL	FINISH									

NUMBER OF CIRCUITS "XX"	DIM. "A"		DIM. "B"		MATERIAL NO. WITH STD. SCREW (-C OPT.)	MATERIAL NO. WITH WIRE READY SCREW (-C-47 OPT.)	MATERIAL NO. WITH BRASS SCREW (-C-49 OPT.)	MATERIAL NO. W/CLAMP-WASHER SCREW (-C-50 OPT.)	UL & CSA REFERENCE NUMBER
02	21.1	[.83]	9.53	[.375]	38721-5302	38721-6202	38721-5602	38721-5902	72
03	30.7	[1.21]	19.05	[.750]	38721-5303	38721-6203	38721-5603	38721-5903	72
04	40.1	[1.58]	28.58	[1.125]	38721-5304	38721-6204	38721-5604	38721-5904	72
05	49.8	[1.96]	38.10	[1.500]	38721-5305	38721-6205	38721-5605	38721-5905	72
06	59.2	[2.33]	47.63	[1.875]	38721-5306	38721-6206	38721-5606	38721-5906	72
07	68.8	[2.71]	57.15	[2.250]	38721-5307	38721-6207	38721-5607	38721-5907	72
08	78.3	[3.08]	66.68	[2.625]	38721-5308	38721-6208	38721-5608	38721-5908	72
09	87.8	[3.46]	76.20	[3.000]	38721-5309	38721-6209	38721-5609	38721-5909	72
10	97.3	[3.83]	85.73	[3.375]	38721-5310	38721-6210	38721-5610	38721-5910	72
11	106.9	[4.21]	95.25	[3.750]	38721-5311	38721-6211	38721-5611	38721-5911	72
12	116.3	[4.58]	104.78	[4.125]	38721-5312	38721-6212	38721-5612	38721-5912	72
13	126.0	[4.96]	114.30	[4.500]	38721-5313	38721-6213	38721-5613	38721-5913	72
14	135.3	[5.33]	123.83	[4.875]	38721-5314	38721-6214	38721-5614	38721-5914	72
15	145.0	[5.71]	133.35	[5.250]	38721-5315	38721-6215	38721-5615	38721-5915	72
16	154.4	[6.08]	142.88	[5.625]	38721-5316	38721-6216	38721-5616	38721-5916	72
17	164.1	[6.46]	152.40	[6.000]	38721-5317	38721-6217	38721-5617	38721-5917	72
18	173.5	[6.83]	161.93	[6.375]	38721-5318	38721-6218	38721-5618	38721-5918	72
19	183.1	[7.21]	171.45	[6.750]	38721-5319	38721-6219	38721-5619	38721-5919	72
20	192.5	[7.58]	180.98	[7.125]	38721-5320	38721-6220	38721-5620	38721-5920	72
21	202.2	[7.96]	190.50	[7.500]	38721-5321	38721-6221	38721-5621	38721-5921	72
22	211.6	[8.33]	200.03	[7.875]	38721-5322	38721-6222	38721-5622	38721-5922	72
23	221.2	[8.71]	209.55	[8.250]	38721-5323	38721-6223	38721-5623	38721-5923	72
24	230.6	[9.08]	219.08	[8.625]	38721-5324	38721-6224	38721-5624	38721-5924	72
25	240.3	[9.46]	228.60	[9.000]	38721-5325	38721-6225	38721-5625	38721-5925	72
26	249.6	[9.83]	238.13	[9.375]	38721-5326	38721-6226	38721-5626	38721-5926	72



NOTES:

- 1 FOR UL OR CSA FILE, USE UL & CSA REFERENCE NO. PROVIDED IN CHART ALONG WITH THE INSTRUCTIONS BELOW.
- 2 FOR ASSEMBLY WITH CLAMP-WASHER SCREW, ADD -50 TO THE UL & CSA REFERENCE NO.

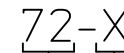

SERIES _____ OPTIONS (WHERE APPLICABLE)

UL & CSA FILE INSTRUCTIONS

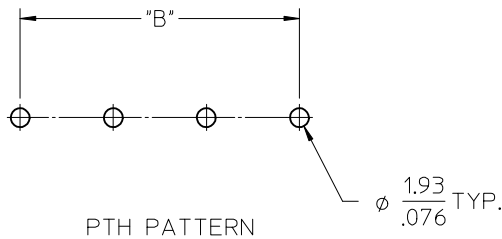

UPDATE TABLE EC NO: WNA2010-0237 DRAWN: C. YORK 2009/10/01 CHKD: DTITUS 2009/10/02 APPR: DTITUS 2009/10/05 REV	QUALITY SYMBOLS ▽=0 ▽=0	GENERAL TOLERANCES (UNLESS SPECIFIED) mm INCH 4 PLACES ± --- ± --- 3 PLACES ± --- ± .005 2 PLACES ± 0.13 ± .01 1 PLACE ± 0.25 ± --- ANGULAR ± 2 °	DIMENSION STYLE MM/IN DRAWN BY DATE C. YORK 2006/02/08 CHECKED BY DATE RDEROSS 2006/02/08 APPROVED BY DATE DTITUS 2009/10/02	SCALE 2:1 DESIGN UNITS INCH THIRD ANGLE PROJECTION	TITLE 9.53/.375 SR BTS ASY, PC RA, NO MTG
	MATERIAL NO. SEE CHART	DOCUMENT NO. SD-38721-001	SHEET NO. 2 OF 2		
	DRAFT WHERE APPLICABLE MUST REMAIN WITHIN DIMENSIONS				
	THIS DRAWING CONTAINS INFORMATION THAT IS PROPRIETARY TO MOLEX INCORPORATED AND SHOULD NOT BE USED WITHOUT WRITTEN PERMISSION				

X-ON Electronics

Largest Supplier of Electrical and Electronic Components

Click to view similar products for [Barrier Terminal Blocks](#) category:

Click to view products by [Molex](#) manufacturer:

Other Similar products are found below :

[CR151D20104](#) [670A-RZ-15-KT20](#) [6C1N03](#) [6PCR-02](#) [6PCR-02-008](#) [6PCR-05-008](#) [6PCR-08-008](#) [6PCR-09-008](#) [6PCR-13-006](#) [6PCR-15-006](#) [6PCR-21-006](#) [6PCV-06-008](#) [6PCV-06-716](#) [6PCV-09-001](#) [6PCV-10-009](#) [6PCV-15-008](#) [6PCV-17-1206](#) [6PCV-20-323](#) [6PCV-20-720](#) [6PCV-30-006](#) [6STR-06-006](#) [6STR-08-006](#) [6STR-12-008](#) [6STR-13-006](#) [6STR-14-008](#) [6STR-16-008](#) [6STR-17-008](#) [6STR-21-008](#) [6STR-25-008](#) [6STR-27-008](#) [6STV-03-006](#) [6STV-03-008](#) [6STV-04-006](#) [6STV-09-006](#) [6STV-10-006](#) [6WWR-03-693](#) [6WWV-12-008](#) [72212603](#) [72506-C](#) [72507-C-50](#) [73203](#) [75505-C](#) [75505-C-50](#) [75510-C](#) [77010-50](#) [7C1N08](#) [812-GP-3/4ST-09](#) [8-1437402-5](#) [8PCR-06-006](#) [8PCR-11-006](#)