

CIRCUIT SIZE	DIM "A"	DIM "B"	DIM "C"	DIM "D"
6	.54 (13.8)	.33 (8.4)	.807 (20.50)	.945 (24.00)
8	.71 (18.0)	.50 (12.6)	.972 (24.70)	1.110 (28.20)
10	.87 (22.2)	.66 (16.8)	1.138 (28.90)	1.276 (32.40)
12	1.04 (26.4)	.83 (21.0)	1.303 (33.10)	1.441 (36.60)
14	1.20 (30.6)	.99 (25.2)	1.469 (37.30)	1.606 (40.80)
16	1.37 (34.8)	1.16 (29.4)	1.643 (41.50)	1.772 (45.00)
18	1.54 (39.0)	1.32 (33.6)	1.799 (45.70)	1.937 (49.20)
20	1.70 (43.2)	1.49 (37.8)	1.965 (49.90)	2.102 (53.40)
22	1.87 (47.4)	1.65 (42.0)	2.130 (54.10)	2.268 (57.60)
24	2.03 (51.6)	1.82 (46.2)	2.295 (58.30)	2.433 (61.80)

**SECTION A-A
TERMINAL ORIENTATION**

**RECOMMENDED CUT-OUT FOR .63/(1.60) MAX.
.038/(0.97) MIN THICK PANEL (6-24 CKT'S)
SCALE : 2X**

NOTES:

- MATERIAL:
"1" = NYLON (PA6/6), UNFILLED, UL94 V-2, COLOR: NATURAL
"2" = NYLON (PA6/6), UNFILLED, UL94 V-0, COLOR: NATURAL
"3" = NYLON (PA6/6), UNFILLED, UL94 V-2, COLOR: BLACK
"4" = NYLON (PA6/6), UNFILLED, UL94 V-0, COLOR: BLACK
"7" = NYLON (PA6/6), UNFILLED, UL94 V-0, GLOW WIRE, COLOR: BLACK
- FINISH: NOT APPLICABLE
- PRODUCT SPECIFICATIONS: PS-5556-002
- PACKAGING: PK-42474-001.
- 6-24 CKT. PARTS MATE WITH MOLEX RECEPTACLES 5557, 42385 AND 42474. 2 AND 4 CKT. PARTS MATE WITH 42385 AND 42474 ONLY.
- PART IS FOR USE WITH MALE TERMINAL #5558.
- PART ALLOWS FOR UP TO .100/(2.54) MISALIGNMENT WITH MATING RECEPTACLE IN ANY DIRECTION. SEE MATING CONNECTOR DRAWINGS FOR SPECIFIC ALLOWANCES.
- PANEL CUT-OUT TO BE PUNCHED IN THE SAME DIRECTION AS CONNECTOR INSERTION.
- PART CONFORMS TO CLASS "B" REQUIREMENTS OF COSMETIC SPECIFICATIONS PS-45499-022.

- FOR MANUFACTURING EASE PARTS MAY HAVE OPTIONAL EJECTOR RIBS. SEE SHT.3 FOR LOCATION.
- DIMENSION DOES NOT INCLUDE EJECTOR RIBS (SEE PAGE #3 FOR PARTS WITH PARTS, RIB DIMENSION AND LOCATION)
- IF THIS PRODUCT IS STORED IN AN ENVIRONMENT WITH A RELATIVE HUMIDITY OF LESS THAN 50%, MOISTURE BE ADDED. REFER TO TECHNICAL ADVISORY AS-45499-001 FOR INSTRUCTIONS.
- INTERIOR RIB LOCATION MAY VARY.

- CONNECTOR ASSEMBLIES ARE NOT TO BE MATED OR UNMATED WHILE CIRCUITS ARE LIVE.
- WIRES ARE TO DRESSED IN SUCH A MANNER TO ALLOW THE TERMINALS TO FLOAT FREELY IN THE POCKET.
- PARTS MAY HAVE OPTIONAL GUSSET.

THIS DRAWING CONTAINS INFORMATION THAT IS PROPRIETARY TO MOLEX ELECTRONIC TECHNOLOGIES, LLC AND SHOULD NOT BE USED WITHOUT WRITTEN PERMISSION													
DIMENSION UNITS IN/MM		SCALE 4:1		CURRENT REV DESC:									
GENERAL TOLERANCES (UNLESS SPECIFIED)				molex PLUG HOUSING B.M.I. 2-24 CIRCUITS MINI-FIT SERIES PRODUCT CUSTOMER DRAWING DOCUMENT NUMBER: SD-42475-XXX1 DOC TYPE: PSD DOC PART: 001 REVISION: T3 MATERIAL NUMBER: SEE SHEET 4 CUSTOMER: GENERAL MARKET SHEET NUMBER: 1 OF 4									
4 PLACES ±		±								EC NO: 690613		2021/12/31	
3 PLACES ±		± 0.01								DRWN: HPAN18		2022/01/04	
2 PLACES ±		± 0.25 ± 0.015								CHK'D: XQZHANG		2022/01/04	
1 PLACE ±		± 0.38 ±								APPR: XQZHANG		2022/01/04	
0 PLACES ±		±		INITIAL REVISION:									
ANGULAR TOL ±		± 0.5 °		DRWN: GEP		1989/07/18		APPR: FSMITH					
DRAFT WHERE APPLICABLE MUST REMAIN WITHIN DIMENSIONS		THIRD ANGLE PROJECTION		DRAWING		SERIES		C-SIZE					
				42475									

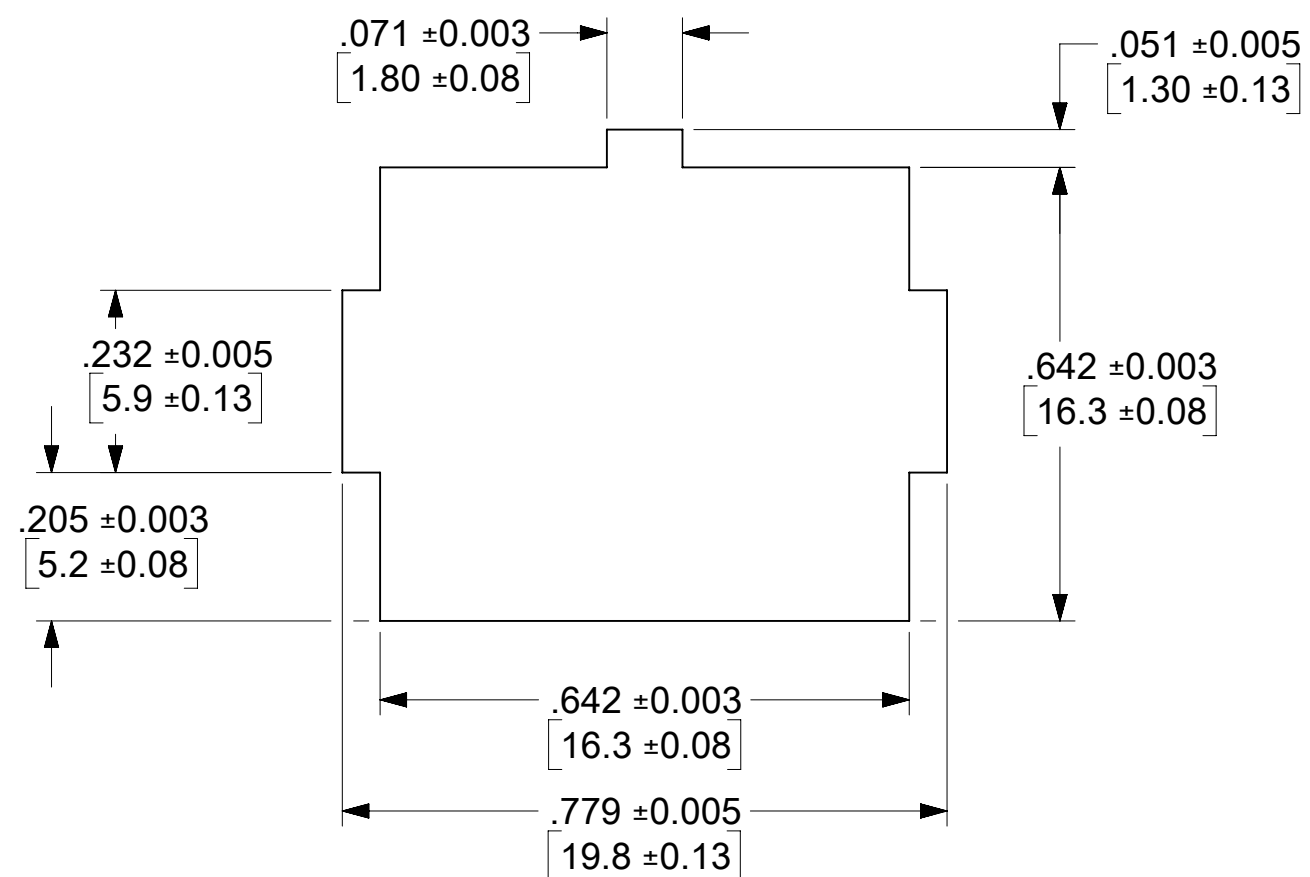
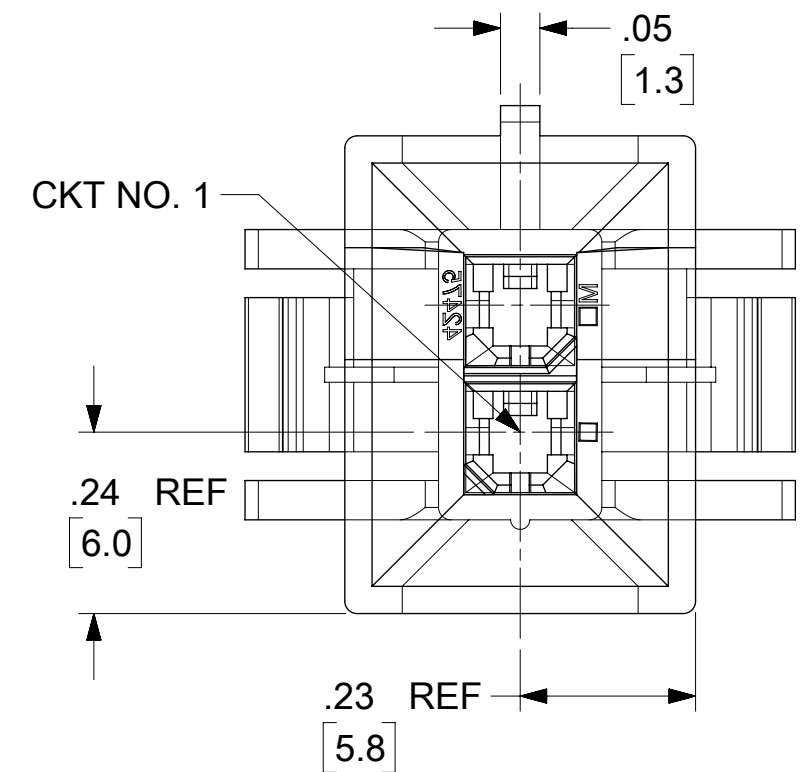
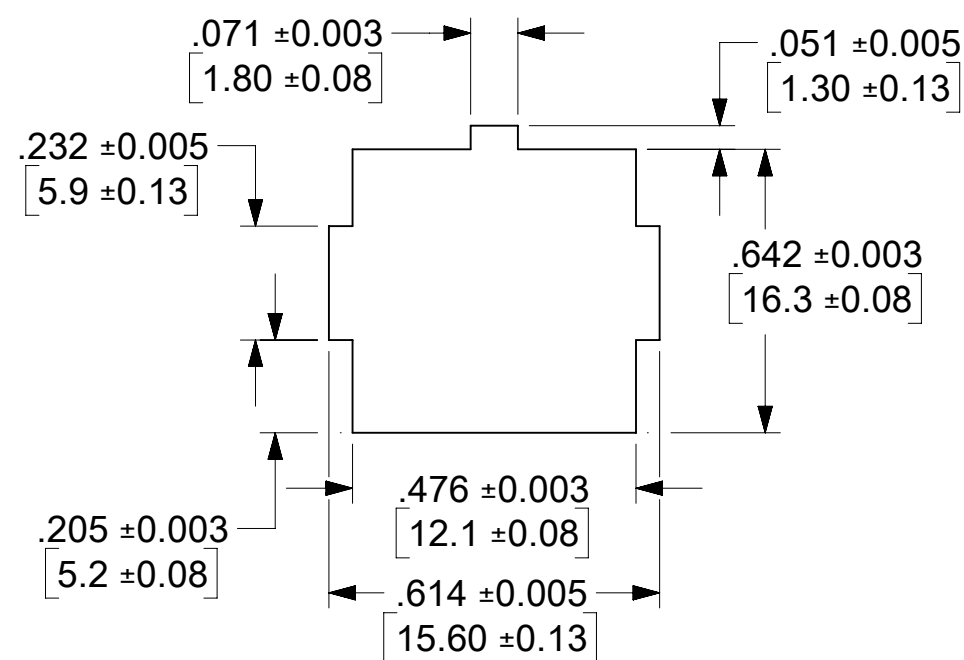
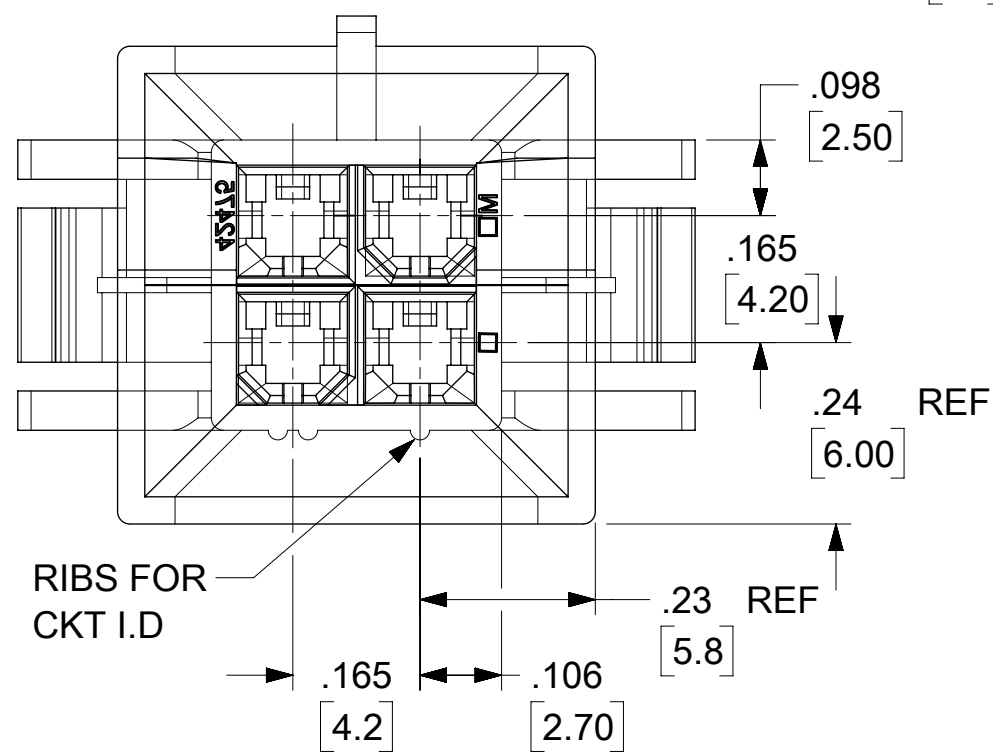
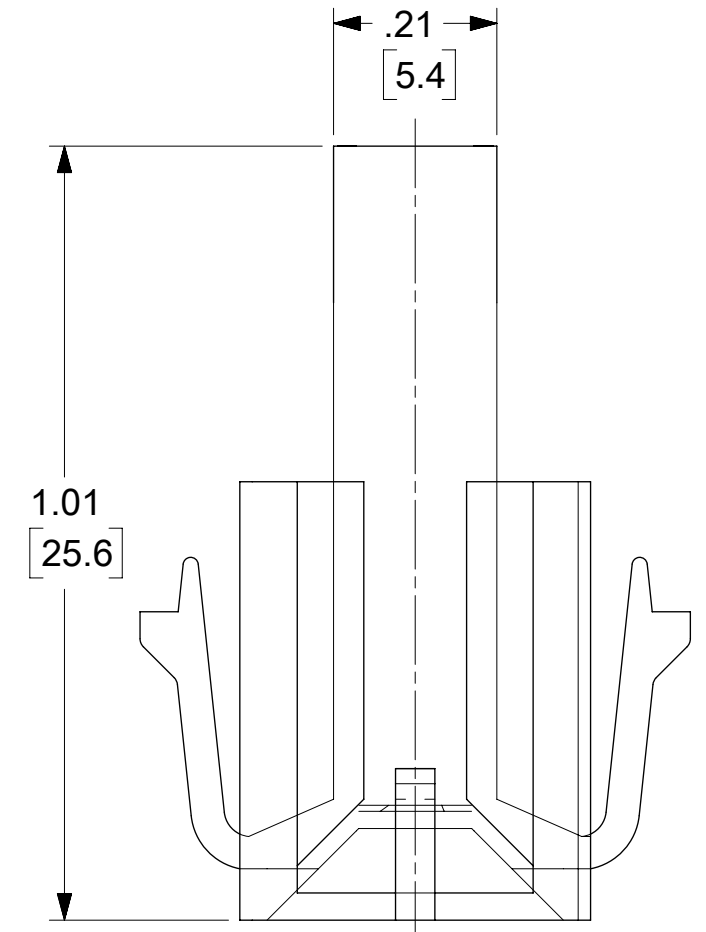
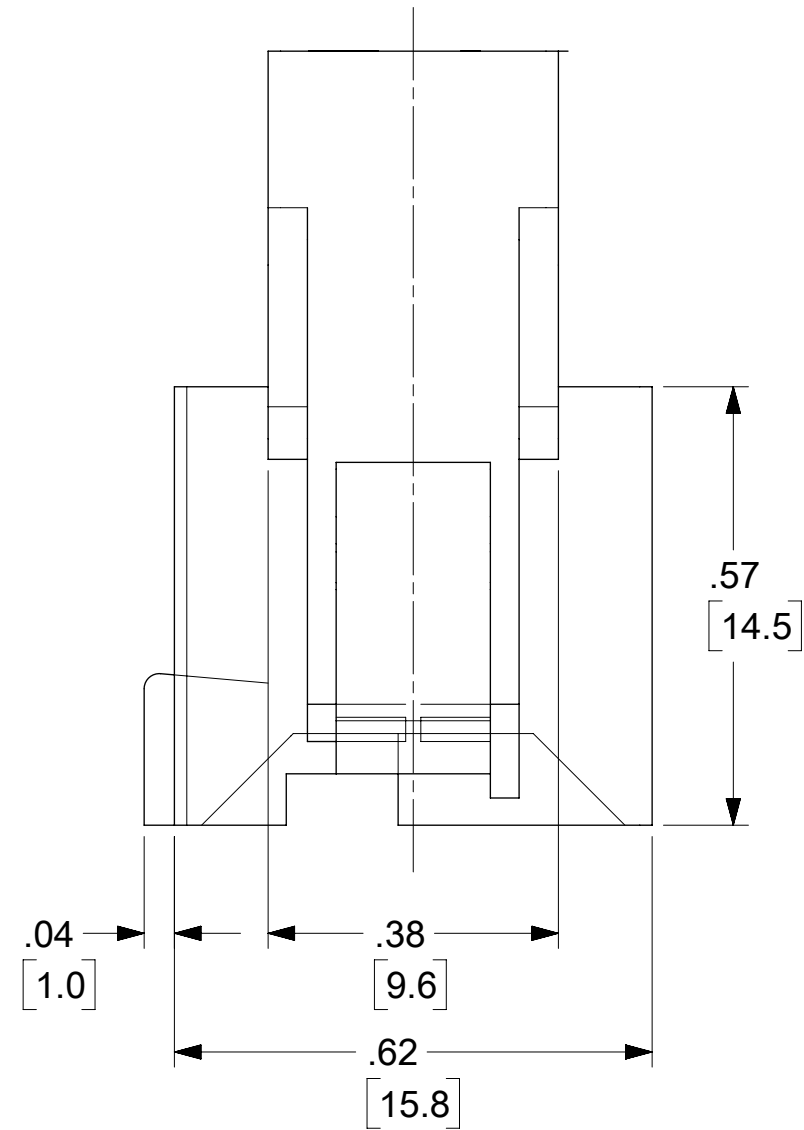
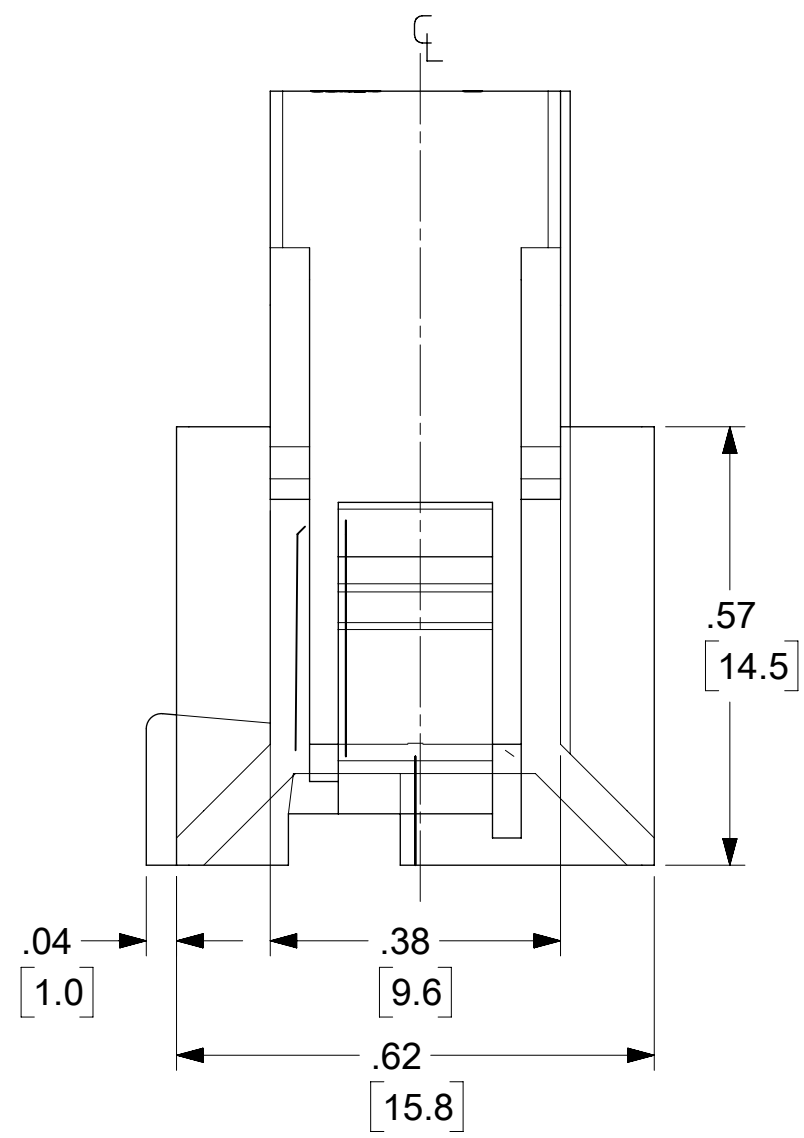
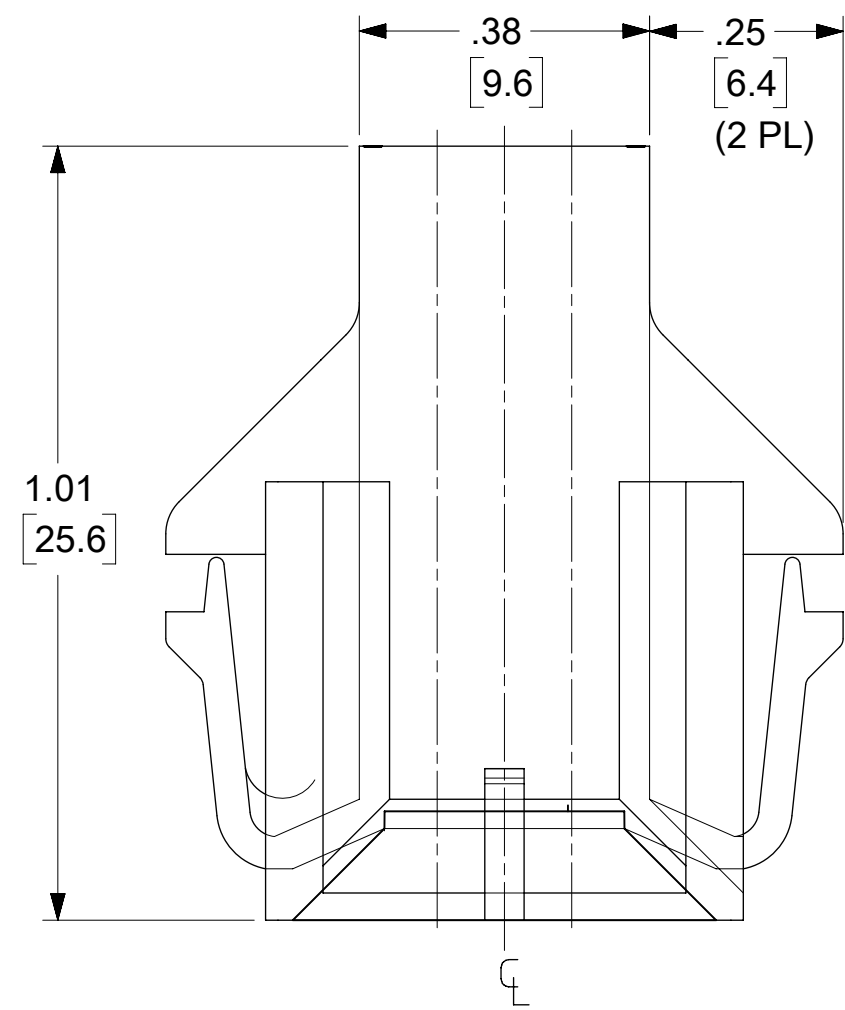

**RECOMMENDED CUT-OUT FOR .63/(1.60)
MAX. THICK PANEL #1 (2 CKTS)
SCALE: 2X
2 CKT**

**RECOMMENDED CUT-OUT FOR .63/(1.60)
MAX. THICK PANEL (4 CKTS)
SCALE: 2X
4 CKT**

THIS DRAWING CONTAINS INFORMATION THAT IS PROPRIETARY TO MOLEX ELECTRONIC TECHNOLOGIES, LLC AND SHOULD NOT BE USED WITHOUT WRITTEN PERMISSION									
DIMENSION UNITS		SCALE		CURRENT REV DESC:					
IN/MM		4:1							
GENERAL TOLERANCES (UNLESS SPECIFIED)									
	MM	INCH							
4 PLACES	±	±		EC NO: 690613					
3 PLACES	±	±	0.01	DRWN: HPAN18		2021/12/31			
2 PLACES	±	0.25	± 0.015	CHK'D: XQZHANG		2022/01/04			
1 PLACE	±	0.38	±	APPR: XQZHANG		2022/01/04			
0 PLACES	±	±		INITIAL REVISION:					
ANGULAR TOL		± 0.5 °		DRWN: GEP		1989/07/18			
DRAFT WHERE APPLICABLE MUST REMAIN WITHIN DIMENSIONS		THIRD ANGLE PROJECTION		APPR: FSMITH		2011/09/02			
		DRAWING		SERIES		DOCUMENT NUMBER		DOC TYPE DOC PART REVISION	
		C-SIZE		42475		SD-42475-XXX1		PSD 001 T3	
		MATERIAL NUMBER		CUSTOMER		SHEET NUMBER			
		SEE SHEET 4		GENERAL MARKET		2 OF 4			

molex

PLUG HOUSING B.M.I.
2-24 CIRCUITS MINI-FIT SERIES

PRODUCT CUSTOMER DRAWING

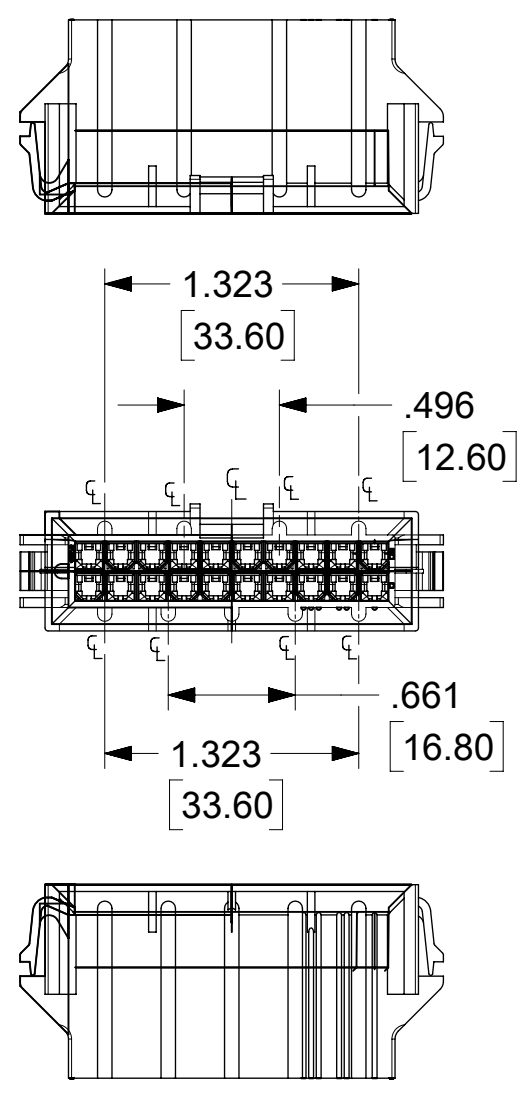

20 CIRCUIT

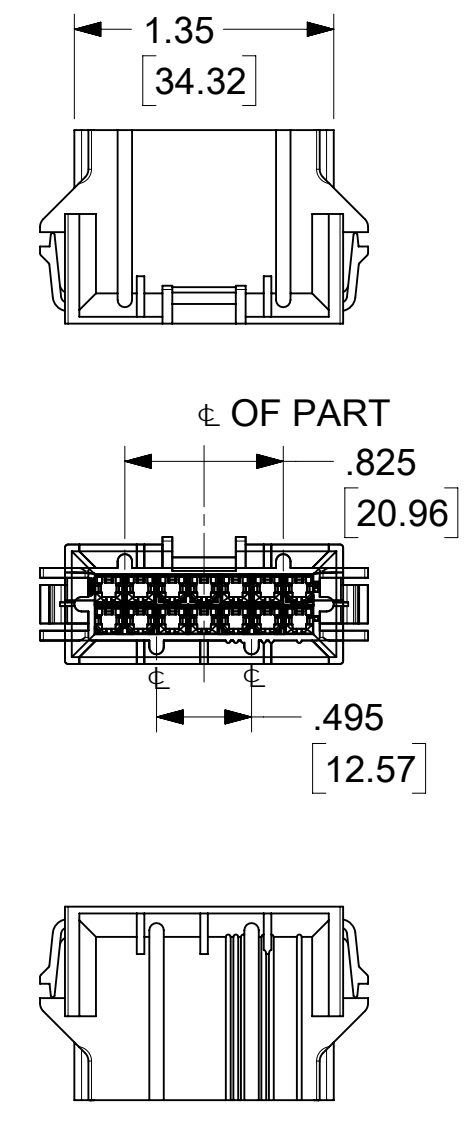

14 CIRCUIT

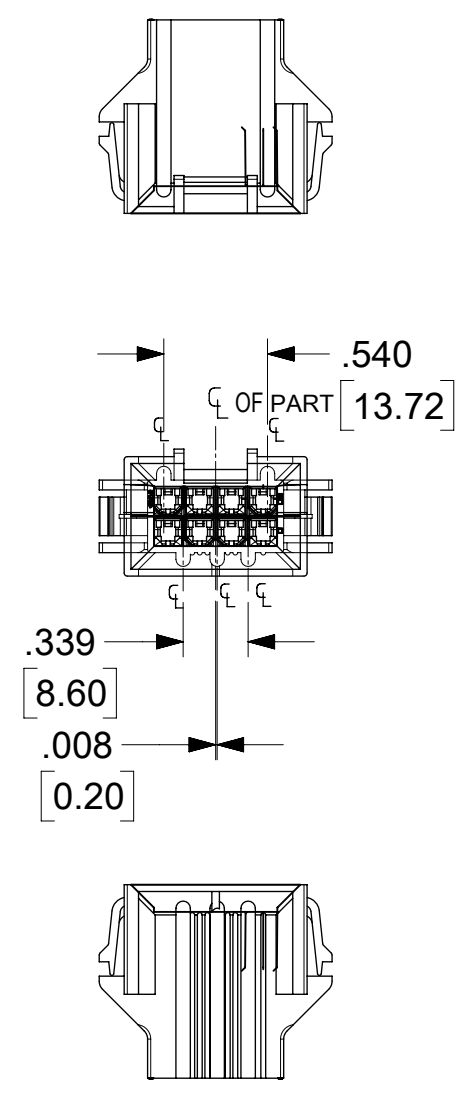

8 CIRCUIT

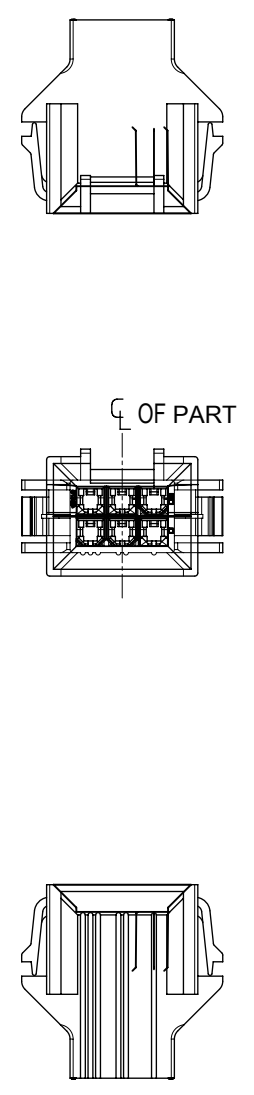

6 CIRCUIT

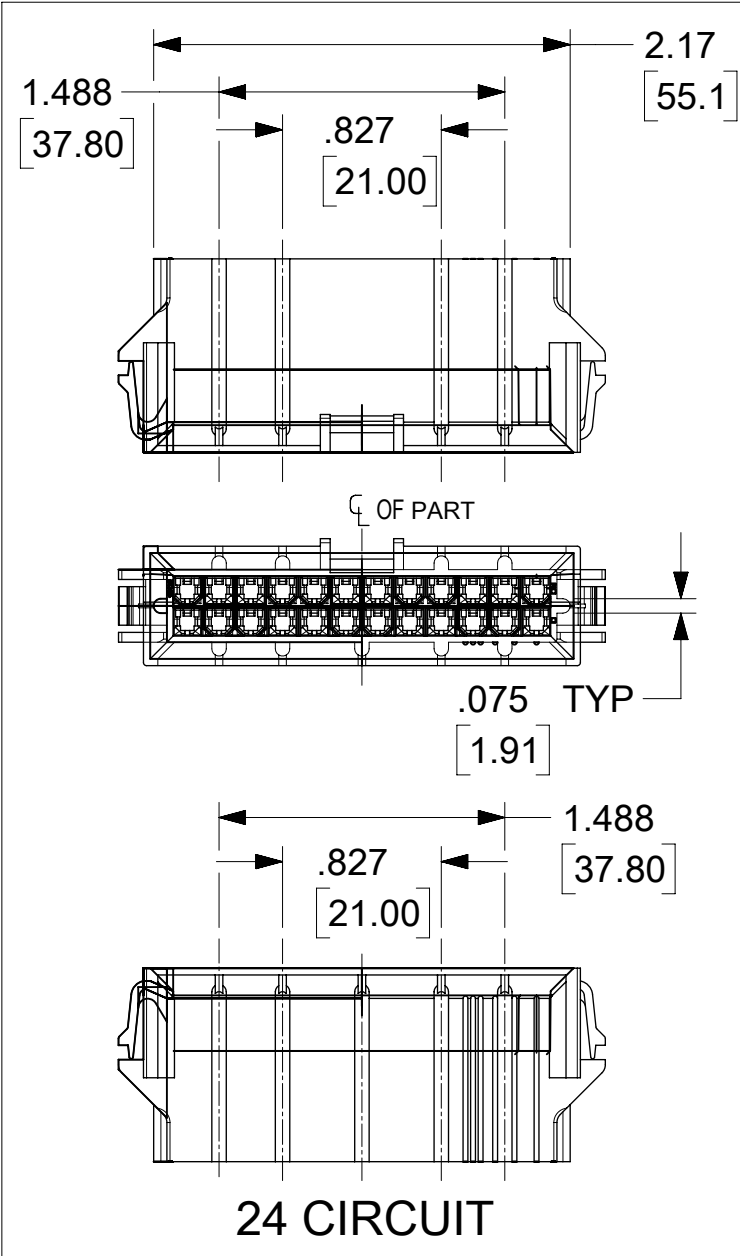

24 CIRCUIT

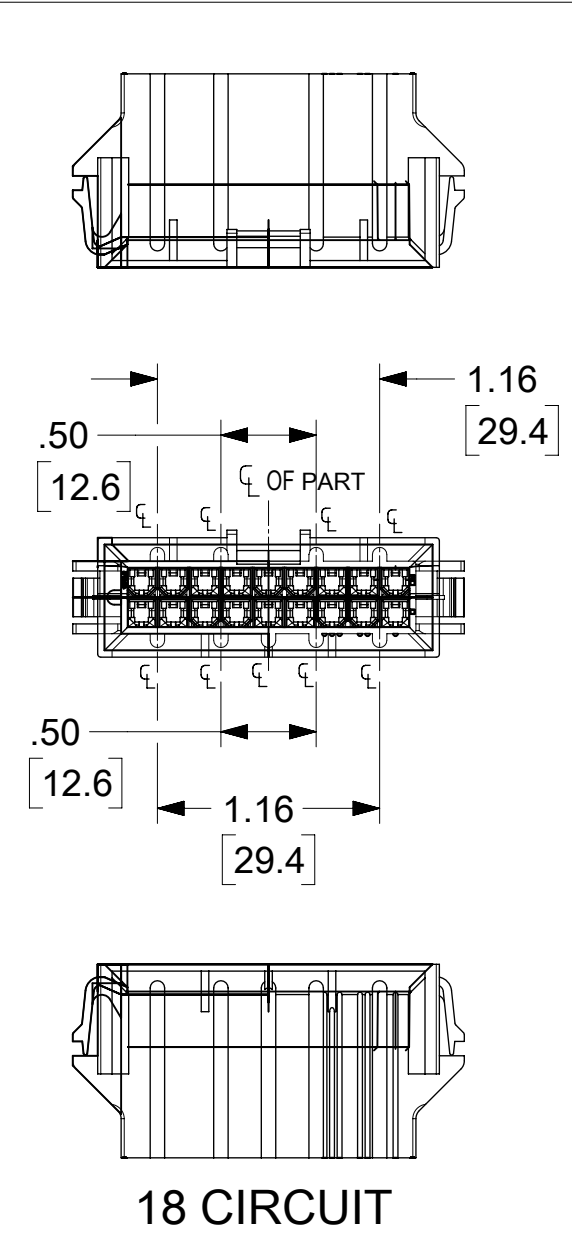

18 CIRCUIT

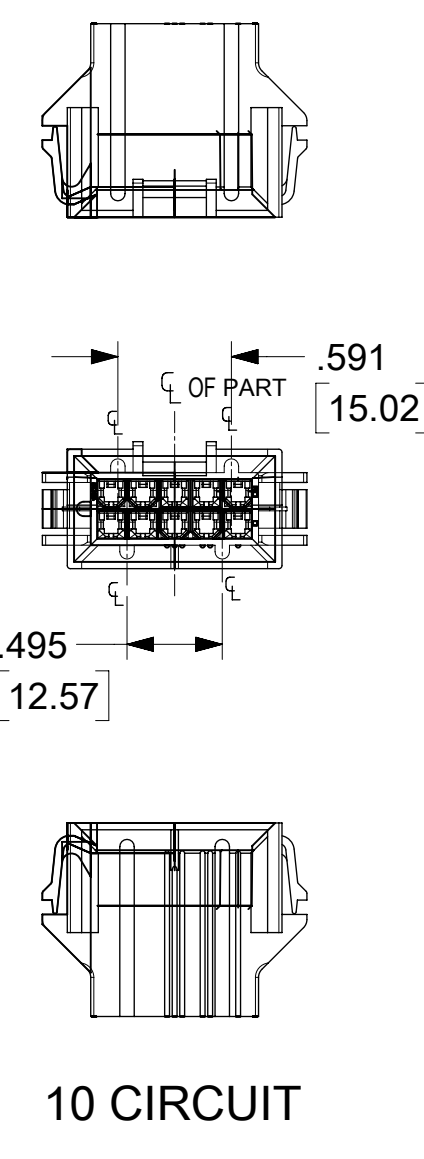
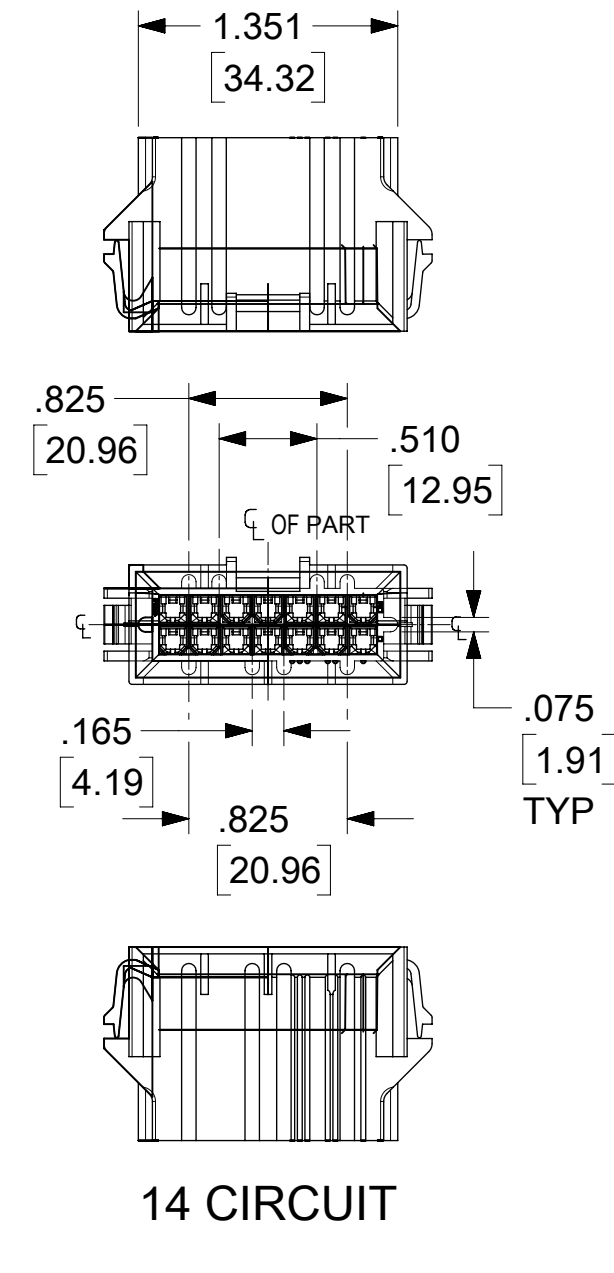

10 CIRCUIT

NOTES:
 1. DIMENSIONS GIVEN ACROSS CENTERLINES ARE SYMMETRICAL ABOUT THOSE CENTERLINES WITHIN HALF THE TOTAL TOLERANCE.

THIS DRAWING CONTAINS INFORMATION THAT IS PROPRIETARY TO MOLEX ELECTRONIC TECHNOLOGIES, LLC AND SHOULD NOT BE USED WITHOUT WRITTEN PERMISSION									
DIMENSION UNITS IN/MM		SCALE 2:1		CURRENT REV DESC:					
GENERAL TOLERANCES (UNLESS SPECIFIED)				EC NO: 690613		2021/12/31			
				DRWN: HPAN18		2022/01/04			
				CHK'D: XQZHANG		2022/01/04		PLUG HOUSING B.M.I. 2-24 CIRCUITS MINI-FIT SERIES	
				APPR: XQZHANG		2022/01/04		PRODUCT CUSTOMER DRAWING	
				INITIAL REVISION:				DOCUMENT NUMBER	
				DRWN: GEP		1989/07/18		SD-42475-XXX1	
				APPR: FSMITH		2011/09/02		DOC TYPE DOC PART REVISION	
				THIRD ANGLE PROJECTION		DRAWING SERIES		MATERIAL NUMBER CUSTOMER SHEET NUMBER	
				C-SIZE		42475		SEE SHEET 4 GENERAL MARKET 3 OF 4	

PART NUMBER	ENG. NUMBER	CKT SIZE	MATERIAL (SEE NOTE 1)
NOT TOOLED	42475-0211	2	1
15-06-0045	42475-0411	4	▲
15-06-0065	42475-0611	6	
15-06-0085	42475-0811	8	
15-06-0105	42475-1011	10	
NOT TOOLED	42475-1211	12	
15-06-0145	42475-1411	14	
NOT TOOLED	42475-1611	16	
15-06-0185	42475-1811	18	
O 15-06-0205	42475-2011	20	
NOT TOOLED	42475-2211	22	▼
15-06-0245	42475-2411	24	1
NOT TOOLED	42475-0221	2	2
15-06-0046	42475-0421	4	▲
15-06-0066	42475-0621	6	
50-36-2323	42475-0821	8	
15-06-0106	42475-1021	10	
NOT TOOLED	42475-1221	12	
15-06-0146	42475-1421	14	
NOT TOOLED	42475-1621	16	
15-06-0186	42475-1821	18	
O 15-06-0206	42475-2021	20	
NOT TOOLED	42475-2221	22	▼
15-06-0246	42475-2421	24	2
42475-1071	42475-1071	10	7

PART NUMBER	CKT SIZE	MATERIAL (SEE NOTE 1)
NOT TOOLED	2	3
42475-0431	4	▲
42475-0631	6	
42475-0831	8	
42475-1031	10	
NOT TOOLED	12	
42475-1431	14	
NOT TOOLED	16	
42475-1831	18	
O 42475-2031	20	
NOT TOOLED	22	▼
42475-2431	24	3
NOT TOOLED	2	4
42475-0441	4	▲
42475-0641	6	
42475-0841	8	
42475-1041	10	
NOT TOOLED	12	
42475-1441	14	
NOT TOOLED	16	
42475-1841	18	
O 42475-2041	20	
NOT TOOLED	22	▼
42475-2441	24	4

O = OBSOLETE

O = OBSOLETE

LEGEND:

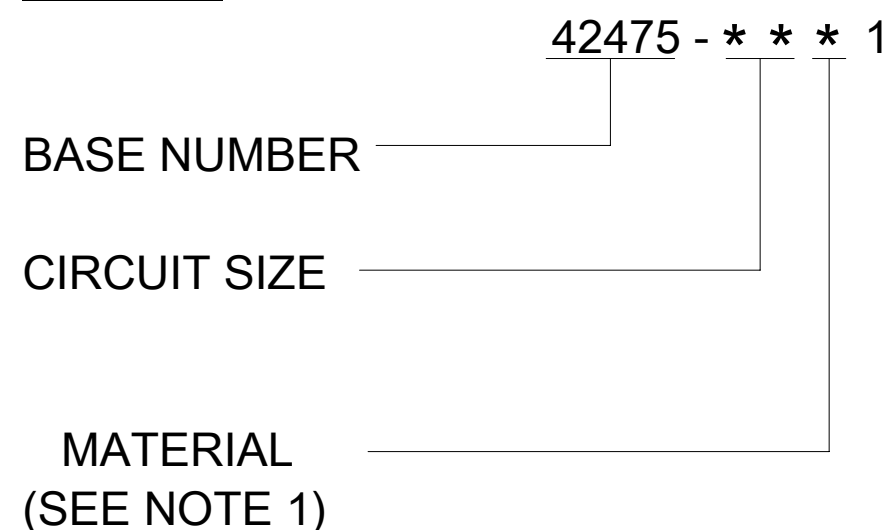

THIS DRAWING CONTAINS INFORMATION THAT IS PROPRIETARY TO MOLEX ELECTRONIC TECHNOLOGIES, LLC AND SHOULD NOT BE USED WITHOUT WRITTEN PERMISSION									
DIMENSION UNITS		SCALE		CURRENT REV DESC:				molex	
IN/MM		1:1							
GENERAL TOLERANCES (UNLESS SPECIFIED)				EC NO: 690613		2021/12/31		PLUG HOUSING B.M.I. 2-24 CIRCUITS MINI-FIT SERIES	
		MM	INCH	DRWN: HPAN18		2022/01/04			
4 PLACES		±	±	CHK'D: XQZHANG		2022/01/04		PRODUCT CUSTOMER DRAWING	
3 PLACES		±	± 0.01	APPR: XQZHANG		2022/01/04			
2 PLACES		± 0.25	± 0.015	INITIAL REVISION:				DOCUMENT NUMBER	
1 PLACE		± 0.38	±	DRWN: GEP		1989/07/18			
0 PLACES		±	±	APPR: FSMITH		2011/09/02		DOC TYPE	
ANGULAR TOL		± 0.5 °		THIRD ANGLE PROJECTION		DRAWING		SERIES	
DRAFT WHERE APPLICABLE MUST REMAIN WITHIN DIMENSIONS				C-SIZE		42475		MATERIAL NUMBER	
								CUSTOMER	
								SHEET NUMBER	
								4 OF 4	

X-ON Electronics

Largest Supplier of Electrical and Electronic Components

Click to view similar products for [Headers & Wire Housings](#) category:

Click to view products by [Molex](#) manufacturer:

Other Similar products are found below :

[892-18-020-10-001101](#) [58102-G61-06LF](#) [582553-1](#) [0009485154](#) [009176003701906](#) [0050291907](#) [LY20-4P-DT1-P1E-BR](#) [02.125.8002.8](#)
[609-3404](#) [61062-3](#) [622-0430](#) [622-3653LF](#) [63453-116](#) [636-1030](#) [636-1427](#) [636-3427](#) [636-4007](#) [641938-9](#) [641991-4](#) [644827-2](#) [65817-010LF](#)
[65817-015LF](#) [65863-015LF](#) [66207-023LF](#) [67095-007LF](#) [67601157](#) [68648-049](#) [70.362.1628.0](#) [70-4210](#) [70-4226B](#) [70-4853B](#) [707-5020](#) [707-5028](#) [71.350.2428.0](#) [71918-208LF](#) [71961-016LF](#) [733-134](#) [733-162](#) [754199-000](#) [760-3052](#) [787-8014-00](#) [79531-3000](#) [FCN-360C032-B](#) [FCN-367T-T012/H](#) [FCN-723D010/2](#) [80.063.4001.1](#) [800-90-001-10-001000](#) [800-90-010-10-002000](#) [801-43-002-10-013000](#) [801-43-006-10-002000](#)