

CKTS	A	B	C
02	.262 6.65	NA	.441 11.20
04	.380 9.65	.118 3.00	.559 14.20
06	.498 12.65	.236 6.00	.677 17.20
08	.616 15.65	.354 9.00	.795 20.20
10	.734 18.65	.472 12.00	.913 23.20
12	.852 21.65	.591 15.00	1.031 26.20
14	.970 24.65	.709 18.00	1.150 29.20
16	1.088 27.65	.827 21.00	1.268 32.20
18	1.206 30.65	.945 24.00	1.386 35.20
20	1.325 33.65	1.063 27.00	1.504 38.20
22	1.443 36.65	1.181 30.00	1.622 41.20
24	1.561 39.65	1.299 33.00	1.740 44.20

- NOTES:**
- HOUSING MATERIAL: GLASS FILLED LIQUID CRYSTAL POLYMER, UL94V-0, COLOR: BLACK  
TERMINAL MATERIAL: BRASS ALLOY
  - FINISH: A = .000060/(0.00152) MIN. REFLOWED MATTE TIN OVER .000050/(0.00127) MIN. NICKEL PLATE. (FINISH IS BRIGHT IN APPEARANCE, THICKNESS AS APPLIED PRIOR TO REFLOW).  
B = .000015/(0.00038) MIN. SELECT GOLD IN CONTACT AREA; .000100/(0.00254) MIN. SELECT MATTE TIN ON SOLDER TAILS; BOTH OVER .000050/(0.00127) MIN. NICKEL PLATE.  
C = .000030/(0.00076) MIN. SELECT GOLD IN CONTACT AREA; .000100/(0.00254) MIN. SELECT MATTE TIN ON SOLDER TAILS; BOTH OVER .000050/(0.00127) MIN. NICKEL PLATE.
  - PRODUCT SPECIFICATION: PS-43045
  - TAPE AND REEL PACK : SEE MOLEX DRAWING 430450010-PK NON-STANDARD TAPE (SHALLOW POCKET WITH LEADER ON COVER TAPE). NOT ALL CIRCUIT SIZES AVAILABLE, SEE DRAWING SD-43045-004 FOR STANDARD TAPE & REEL PACKAGING.
  - MATES WITH MICRO FIT (3.0) RECEPTACLE SERIES 43025
  - THE COPLANARITY DIMENSION IS ESTABLISHED BY PLACING THE ASSEMBLY ON A FLAT SURFACE. THE DISTANCE FROM THAT SURFACE TO THE BOTTOM OF ANY TERMINAL OR SOLDER NAIL MUST NOT EXCEED .006/0.15
  - CIRCUIT SIZES 2-6: "D" IS .265/6.74 FOR .010/0.25 STEP  
CIRCUIT SIZES 8-24: "D" IS .063/1.60 FOR .010/0.25 STEP.
  - TO AVOID INTERFERENCE BETWEEN RECEPTACLE AND PCB, HEADER MUST BE PLACED WITHIN .400/(10.16) MAX. FROM EDGE OF PCB, AS SHOWN IN LOCATION DETAIL.
  - METAL TAB MAY BE FLUSH WITH PCB. NO EXPOSED TRACES OR VIAS ALLOWED NEAR THESE AREAS.
  - THIS PART CONFORMS TO CLASS B REQUIREMENTS OF COSMETIC SPECIFICATION PS-45499-002.
  - TEXT ON PART IS FOR REFERENCE ONLY. TEXT AND TEXT LOCATION MAY VARY DEPENDING ON PART NUMBER AND/OR TOOL.

PCB LAYOUT: COMPONENT SIDE

CIRCUIT "1" IDENTIFIED ON THIS SURFACE (APPROX. LOCATION SHOWN FOR REF.)

NOTE 9

"X" - DENOTES NOT AVAILABLE, CONSULT FACTORY SEE NOTE #4

CKTS	FINISH		
	FINISH A	FINISH B	FINISH C
02	X 43045-0238	X 43045-0244	X 43045-0245
04	43045-0438	43045-0444	43045-0445
06	43045-0638	43045-0644	43045-0645
08	X 43045-0838	X 43045-0844	X 43045-0845
10	X 43045-1038	X 43045-1044	X 43045-1045
12	43045-1238	43045-1244	43045-1245
14	43045-1438	43045-1444	43045-1445
16	43045-1638	43045-1644	43045-1645
18	X 43045-1838	X 43045-1844	X 43045-1845
20	X 43045-2038	X 43045-2044	X 43045-2045
22	X 43045-2238	X 43045-2244	X 43045-2245
24	X 43045-2438	X 43045-2444	X 43045-2445

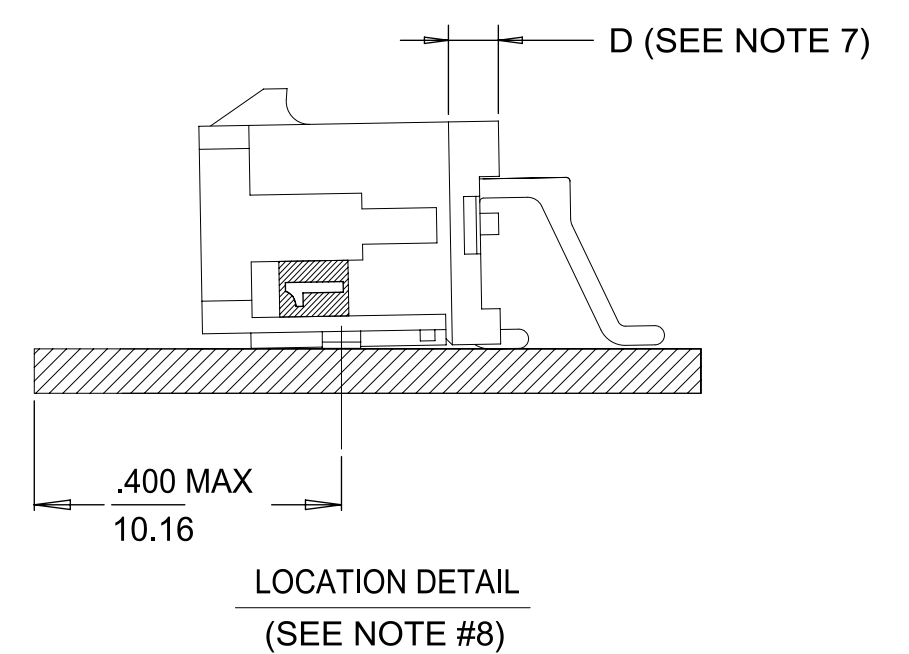
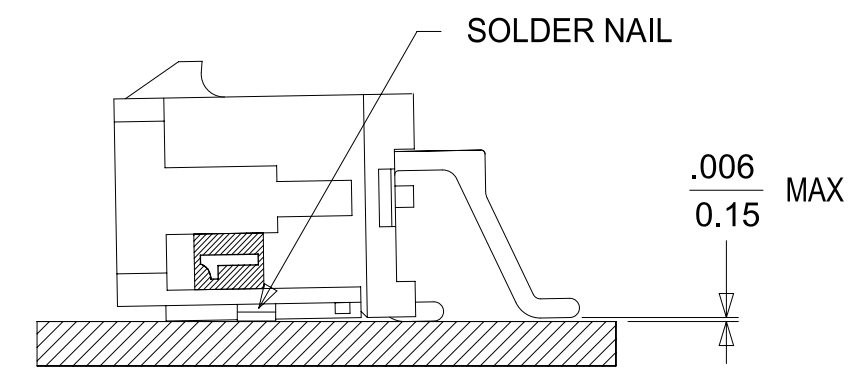

THIS DRAWING CONTAINS INFORMATION THAT IS PROPRIETARY TO MOLEX ELECTRONIC TECHNOLOGIES, LLC AND SHOULD NOT BE USED WITHOUT WRITTEN PERMISSION

SYMBOLS	DIMENSION UNITS	SCALE	CURRENT REV/DESC: MICROFIT PK SPEC REF
	IN/MM	NTS	
GENERAL TOLERANCES (UNLESS SPECIFIED)	MM	INCH	EC NO: 611607 DRWN: SALHAMY 2019/01/03 CHK'D: SSOUSEK 2019/08/09 APPR: FSMITH 2019/08/15
	4 PLACES ±	±	
INITIAL REVISION:	3 PLACES ±	± 0.01	DRWN: CSLAFTER 2016/01/15 APPR: FSMITH 2016/01/15
	2 PLACES ±	± 0.014	
DRAFT WHERE APPLICABLE MUST REMAIN WITHIN DIMENSIONS	1 PLACE ±	± 0.36	THIRD ANGLE PROJECTION
	0 PLACES ±	±	
DRAWING SERIES	ANGULAR TOL ± 0.5°		C-SIZE 43045
DOCUMENT NUMBER	CUSTOMER	DOC TYPE	DOC PART
SD-43045-013	GENERAL MARKET	PSD	000 H4
MATERIAL NUMBER	CUSTOMER	SHEET NUMBER	
SEE CHART	GENERAL MARKET	1 OF 1	

## X-ON Electronics

Largest Supplier of Electrical and Electronic Components

*Click to view similar products for [Headers & Wire Housings](#) category:*

*Click to view products by [Molex](#) manufacturer:*

Other Similar products are found below :

[892-18-020-10-001101](#) [58102-G61-06LF](#) [582553-1](#) [0009485154](#) [009176003701906](#) [0050291907](#) [LY20-4P-DT1-P1E-BR](#) [02.125.8002.8](#)  
[609-3404](#) [61062-3](#) [622-0430](#) [622-3653LF](#) [63453-116](#) [636-1030](#) [636-1427](#) [636-3427](#) [636-4007](#) [641938-9](#) [641991-4](#) [644827-2](#) [65817-010LF](#)  
[65817-015LF](#) [65863-015LF](#) [66207-023LF](#) [67095-007LF](#) [67601157](#) [68648-049](#) [70.362.1628.0](#) [70-4210](#) [70-4226B](#) [70-4853B](#) [707-5020](#) [707-](#)  
[5028](#) [71.350.2428.0](#) [71918-208LF](#) [71961-016LF](#) [733-134](#) [733-162](#) [754199-000](#) [760-3052](#) [787-8014-00](#) [79531-3000](#) [FCN-360C032-B](#) [FCN-](#)  
[367T-T012/H](#) [FCN-723D010/2](#) [80.063.4001.1](#) [800-90-001-10-001000](#) [800-90-010-10-002000](#) [801-43-002-10-013000](#) [801-43-006-10-002000](#)