

18 CKT PART SHOWN

- NOTES:**
- HOUSING MATERIAL: A = NYLON 6/6. U.L. 94V-2. COLOR: NATURAL.  
B = NYLON 6/6. U.L. 94V-0. COLOR: NATURAL.  
C = PBT POLYESTER 94V-0 COLOR: BLACK
  - TERMINAL MATERIAL: BRASS ALLOY
  - TERMINAL PLATING  
A = .000100/(.00254) MIN. MATTE TIN OVER  
.000050/(.00127) MIN. NICKEL.  
C = .000030/(0.00076) MIN. SELECT GOLD AND  
.000100/(0.00254) MIN. SELECT MATTE TIN  
OVER .000050/(0.00127) MIN. NICKEL OVERALL  
D = .000060/(0.00152) MIN REFLOWED MATTE TIN OVER  
.000050/(0.00127) MIN. NICKEL OVERALL.
  - PRODUCT SPECIFICATION: PS-5556-002
  - PACKAGING IN TRAYS PER PK-42404-002 EXCEPT 43693-0024 PACKAGED BULK
  - PART MATES WITH MINI-FIT JR. RECEPTACLES 5557, 42385, 42474 AND 44516.
  - PART ALLOWS FOR UP TO .100(2.54) MISALIGNMENT WITH MATING RECEPTACLE IN ANY DIRECTION. SEE MATING CONNECTOR DRAWINGS FOR SPECIFIC ALLOWANCE.
  - PARTS ARE NOT DESIGNED FOR CURRENT SHARING.
  - CONNECTORS ASSEMBLIES ARE NOT TO BE MATED OR UNMATED WHILE CIRCUITS ARE LIVE.
  - SEE CHART ON SHEET 2 FOR STANDARD, MAKE-FIRST/BREAK-LAST AND PLATING LOCATIONS.
  - ITEM NUMBERS PRECEDED BY AN "X" IN THE CHART ARE NOT AVAILABLE.
  - REFERENCE DIMENSION "C" NOT TO EXCEED .283(7.20) NOMINAL.
  - DISCOLORATION IN THE BANDOLIER CARRIER AREA OF THE PIN IS INHERENT TO THE PLATING PROCESS AND IS DUE TO THE MASKING EFFECT OF THE CARRIER. THIS DISCOLORATION IS IN A NON-FUNCTIONAL AREA OF THE PIN AND WILL NOT AFFECT THE PERFORMANCE OF THE HEADER ASSEMBLY.
  - PART CONFORMS TO CLASS "B" REQUIREMENTS OF COSMETIC SPECIFICATION PS-45499-002, EXCEPT CLASS "C" ON BOTH SIDE RIBS.
  - CUT OFF PEGS NOT TO PROTRUDE MORE THAN .030(0.76) ON ALL CIRCUIT SIZES EXCEPT 18 CIRCUIT PARTS WILL NOT HAVE CUT OFF PEGGS.

36	2.811 (71.40)	3.236 (82.20)
24	1.819 (46.20)	2.244 (57.00)
22	1.654 (42.00)	2.079 (52.80)
20	1.488 (37.80)	1.913 (48.60)
18	1.323 (33.60)	1.748 (44.40)
16	1.157 (29.40)	1.583 (40.20)
14	.992 (25.20)	1.417 (36.00)
12	.827 (21.00)	1.252 (31.80)
10	.661 (16.80)	1.087 (27.60)
8	.496 (12.60)	.921 (23.40)
6	.331 (8.40)	.756 (19.20)
4	.165 (4.20)	.590 (15.00)
2	—	.425 (10.80)
CKT. SIZE	DIM. "A"	DIM. "B"

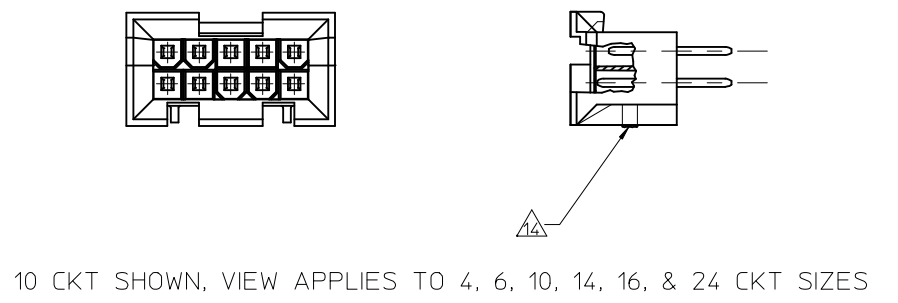
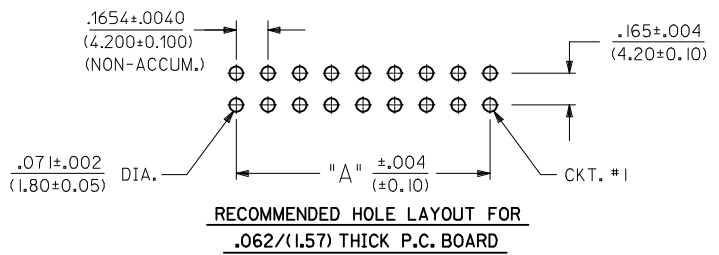

UPDATE NOTE 14 EC NO: UCP2015-4258 DRWN: JONT CHKD: JBELL APPR: FSMITH	2015/06/25 2015/06/25 2015/07/10	DESCRIPTION REV	QUALITY SYMBOLS ▽=0 ▽=0 ▽=0
--	--	--------------------	--------------------------------------

GENERAL TOLERANCES (UNLESS SPECIFIED)	DIMENSION STYLE IN/MM		SCALE 2:1	DESIGN UNITS METRIC	THIRD ANGLE PROJECTION
	mm	INCH	DRAWN BY GEP	DATE 3/11/96	TITLE VERT. HEADER ASSY WITH MAKE-FIRST/BREAK-LAST MINI-FIT B.M.I. SERIES
4 PLACES ± --- ± ---	3 PLACES ± --- ± .015	2 PLACES ± 0.38 ± ---	CHECKED BY RFJ	DATE 3/11/96	MOLEX INCORPORATED
1 PLACE ± --- ± ---	ANGULAR ±1/2°		APPROVED BY RFJ	DATE 3/11/96	
DRAFT WHERE APPLICABLE MUST REMAIN WITHIN DIMENSIONS		SIZE C	MATERIAL NO. SEE CHART	DOCUMENT NO. SDA-43693-****	SHEET NO. 1 OF 2
THIS DRAWING CONTAINS INFORMATION THAT IS PROPRIETARY TO MOLEX INCORPORATED AND SHOULD NOT BE USED WITHOUT WRITTEN PERMISSION					

ITEM NO.	CHARACTERISTIC DESCRIPTION	CKT. SIZE	TERMINAL VERSION REQUIRED AT EACH CIRCUIT LOCATION: 'S' = STD. LENGTH 'M' = MAKE-FIRST/BREAK-LAST 'V' = VOIDED CIRCUIT																																				DIM 'C' REF.
			1	2	3	4	5	6	7	8	9	10	11	12	13	14	15	16	17	18	19	20	21	22	23	24	25	26	27	28	29	30	31	32	33	34	35	36	
43693-0001	IOAC	10	CS	CS	CM	CS	CS	CS	CS	CM	CS	CS	-	-	-	-	-	-	-	-	-	-	-	-	-	-	-	-	-	-	-	-	-	-	-	-	-	.283 (7.20)	
43693-0002	24BA	24	AM	AM	AM	AM	AM	AM	AM	AM	AM	AM	AM	AM	AM	AM	AM	AS	AM	AM	AM	AM	AM	AM	AM	-	-	-	-	-	-	-	-	-	-	-	-	.154 (3.91)	
43693-0005	I6BA	16	AS	AS	AS	AS	AS	AS	AS	AS	AS	AS	AS	AS	AS	AS	-	-	-	-	-	-	-	-	-	-	-	-	-	-	-	-	-	-	-	-	.150 (3.81)		
43693-0020	I8BA	18	AS	AS	AS	AS	AS	AS	AS	AS	AS	AS	AS	AS	AS	AS	AS	AS	-	-	-	-	-	-	-	-	-	-	-	-	-	-	-	-	-	-	.209 (5.31)		
43693-0022	IOBA	10	AS	AM	AM	AM	AM	AM	AM	AM	AM	AM	-	-	-	-	-	-	-	-	-	-	-	-	-	-	-	-	-	-	-	-	-	-	-	-	.321 (8.15)		
43693-0024	IOBC	10	CS	CS	CM	CS	CS	CM	CM	CM	CS	CS	-	-	-	-	-	-	-	-	-	-	-	-	-	-	-	-	-	-	-	-	-	-	-	-	.258 (6.55)		
43693-0027	I8BA	18	AS	AM	AM	AM	AM	AM	AM	AM	AM	AM	AM	AM	AM	AM	AM	AM	AS	-	-	-	-	-	-	-	-	-	-	-	-	-	-	-	-	-	.283 (7.20)		
43693-0030	I8BA	18	AS	AS	AS	AS	AS	AS	AS	AS	AS	AS	AS	AS	AS	AS	AS	AS	-	-	-	-	-	-	-	-	-	-	-	-	-	-	-	-	-	-	.154 (3.91)		
43693-0031	I8BA	18	AM	AM	AM	AM	AM	AM	AM	AM	AM	AM	AM	AM	AM	AM	AM	-	-	-	-	-	-	-	-	-	-	-	-	-	-	-	-	-	-	-	.154 (3.91)		
43693-0037	I8BD	18	DS	DM	DM	DM	DM	DM	DM	DM	DM	DM	DM	DM	DM	DM	DM	DM	-	-	-	-	-	-	-	-	-	-	-	-	-	-	-	-	-	-	.258 (6.55)		

X = NOT AVAILABLE SEE NOTE 10

**CHARACTERISTICS LEGEND:**

CIRCUIT SIZE                 
(02-24 & 36)

HOUSING MAT'L. (SEE NOTE 1)  
 \*A\* = NYLON 6/6, U.L. 94V-2, COLOR: NATURAL  
 \*B\* = NYLON 6/6, U.L. 94V-0, COLOR: NATURAL  
 \*C\* = PBT POLYESTER 94V-0, COLOR: BLACK

**TERMINAL PLATING (SEE NOTE 2)**  
 A = MATTE TIN  
 C = SELECT GOLD  
 D = REFLOW MATTE TIN

SEE SHEET 1  
 EC NO: UCP2015-4258  
 DRWN: MONTI 2015/06/25  
 CHKD: JELL 2015/06/25  
 APPR: FSMITH 2015/07/10

DESCRIPTION: REV

QUALITY SYMBOLS

▽=0  
 ▽=0  
 ▿=0

GENERAL TOLERANCES (UNLESS SPECIFIED)

	mm	INCH
4 PLACES	± .015	± .0006
3 PLACES	± .020	± .0008
2 PLACES	± 0.38	± .015
1 PLACE	± .025	± .0010

ANGULAR ±1/2°

DRAFT WHERE APPLICABLE MUST REMAIN WITHIN DIMENSIONS

DIMENSION STYLE IN/MM

DRAWN BY DATE GEP 3/11/96

CHECKED BY DATE RFJ 3/11/96

APPROVED BY DATE RFJ 3/11/96

MATERIAL NO. SEE CHART

SIZE THIS DRAWING CONTAINS INFORMATION THAT IS PROPRIETARY TO MOLEX INCORPORATED AND SHOULD NOT BE USED WITHOUT WRITTEN PERMISSION

SCALE DESIGN UNITS METRIC

THIRD ANGLE PROJECTION

TITLE VERT. HEADER ASSY WITH MAKE-FIRST/BREAK-LAST MINI-FIT B.M.I. SERIES

**MOLEX** MOLEX INCORPORATED

DOCUMENT NO. SDA-43693-\*\*\*\*

SHEET NO. 2 OF 2

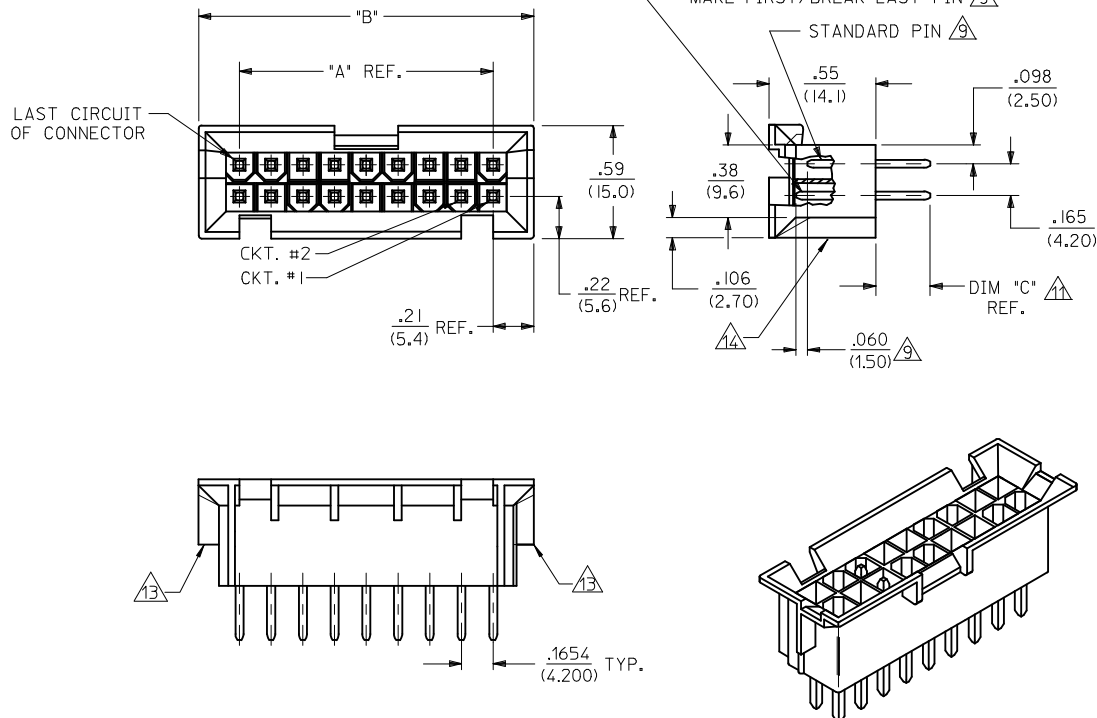

18 CKT PART SHOWN

- NOTES:**
- HOUSING MATERIAL: A = NYLON 6/6. U.L. 94V-2. COLOR: NATURAL.  
B = NYLON 6/6. U.L. 94V-0. COLOR: NATURAL.  
C = PBT POLYESTER 94V-0 COLOR: BLACK
  - TERMINAL MATERIAL: BRASS ALLOY
  - TERMINAL PLATING  
A = .000100/(.00254) MIN. MATTE TIN OVER  
.000050/(.00127) MIN. NICKEL.  
C = .000030/(0.00076) MIN. SELECT GOLD AND  
.000100/(0.00254) MIN. SELECT MATTE TIN  
OVER .000050/(0.00127) MIN. NICKEL OVERALL  
D = .000060/(0.00152) MIN REFLOWED MATTE TIN OVER  
.000050/(0.00127) MIN. NICKEL OVERALL.
  - PRODUCT SPECIFICATION: PS-5556-002
  - PACKAGING IN TRAYS PER PK-42404-002 EXCEPT 43693-0024 PACKAGED BULK
  - PART MATES WITH MINI-FIT JR. RECEPTACLES 5557, 42385, 42474 AND 44516.
  - PART ALLOWS FOR UP TO .100(2.54) MISALIGNMENT WITH MATING RECEPTACLE IN ANY DIRECTION. SEE MATING CONNECTOR DRAWINGS FOR SPECIFIC ALLOWANCE.
  - PARTS ARE NOT DESIGNED FOR CURRENT SHARING.
  - CONNECTORS ASSEMBLIES ARE NOT TO BE MATED OR UNMATED WHILE CIRCUITS ARE LIVE.
  - SEE CHART ON SHEET 2 FOR STANDARD, MAKE-FIRST/BREAK-LAST AND PLATING LOCATIONS.
  - ITEM NUMBERS PRECEDED BY AN "X" IN THE CHART ARE NOT AVAILABLE.
  - REFERENCE DIMENSION "C" NOT TO EXCEED .283(7.20) NOMINAL.
  - DISCOLORATION IN THE BANDOLIER CARRIER AREA OF THE PIN IS INHERENT TO THE PLATING PROCESS AND IS DUE TO THE MASKING EFFECT OF THE CARRIER. THIS DISCOLORATION IS IN A NON-FUNCTIONAL AREA OF THE PIN AND WILL NOT AFFECT THE PERFORMANCE OF THE HEADER ASSEMBLY.
  - PART CONFORMS TO CLASS "B" REQUIREMENTS OF COSMETIC SPECIFICATION PS-45499-002, EXCEPT CLASS "C" ON BOTH SIDE RIBS.
  - CUT OFF PEGS NOT TO PROTRUDE MORE THAN .030(0.76) ON ALL CIRCUIT SIZES EXCEPT 18 CIRCUIT PARTS WILL NOT HAVE CUT OFF PEGS.

36	2.811 (71.40)	3.236 (82.20)
24	1.819 (46.20)	2.244 (57.00)
22	1.654 (42.00)	2.079 (52.80)
20	1.488 (37.80)	1.913 (48.60)
18	1.323 (33.60)	1.748 (44.40)
16	1.157 (29.40)	1.583 (40.20)
14	.992 (25.20)	1.417 (36.00)
12	.827 (21.00)	1.252 (31.80)
10	.661 (16.80)	1.087 (27.60)
8	.496 (12.60)	.921 (23.40)
6	.331 (8.40)	.756 (19.20)
4	.165 (4.20)	.590 (15.00)
2	—	.425 (10.80)
CKT. SIZE	DIM. "A"	DIM. "B"

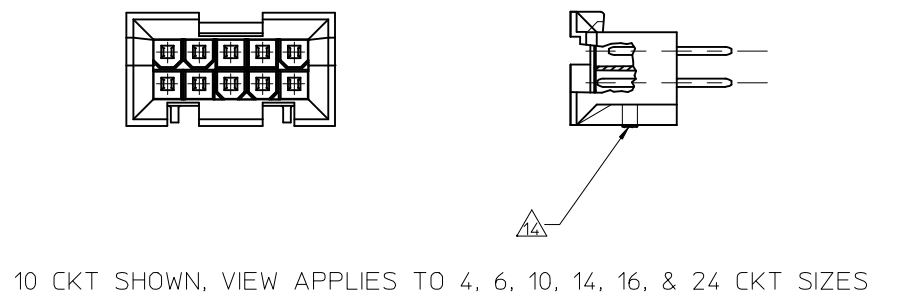
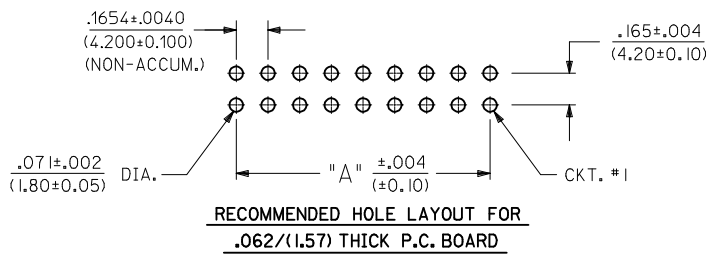

UPDATE NOTE 14 EC NO: UCP2015-4258 DRWN: JONT CHKD: JBELL APPR: FSMITH	2015/06/25 2015/06/25 2015/07/10	DESCRIPTION REV	QUALITY SYMBOLS ▽=0 ▽=0 ▽=0
--	--	--------------------	--------------------------------------

GENERAL TOLERANCES (UNLESS SPECIFIED)	DIMENSION STYLE IN/MM		SCALE 2:1	DESIGN UNITS METRIC	THIRD ANGLE PROJECTION
	mm	INCH	DRAWN BY GEP	DATE 3/11/96	TITLE VERT. HEADER ASSY WITH MAKE-FIRST/BREAK-LAST MINI-FIT B.M.I. SERIES
4 PLACES ± ---	± ---	CHECKED BY RFJ	DATE 3/11/96	APPROVED BY RFJ	
3 PLACES ± ---	± .015	DATE 3/11/96	MATERIAL NO. DOCUMENT NO.		
2 PLACES ± 0.38	± ---	MATERIAL NO. DOCUMENT NO.			
1 PLACE ± ---	± ---	DATE 3/11/96			
ANGULAR ±1/2°		SEE CHART		MOLEX INCORPORATED	
DRAFT WHERE APPLICABLE MUST REMAIN WITHIN DIMENSIONS		THIS DRAWING CONTAINS INFORMATION THAT IS PROPRIETARY TO MOLEX INCORPORATED AND SHOULD NOT BE USED WITHOUT WRITTEN PERMISSION		SHEET NO. 1 OF 2	

ITEM NO.	CHARACTERISTIC DESCRIPTION	CKT. SIZE	TERMINAL VERSION REQUIRED AT EACH CIRCUIT LOCATION: 'S' = STD. LENGTH 'M' = MAKE-FIRST/BREAK-LAST 'V' = VOIDED CIRCUIT																																				DIM 'C' REF.
			1	2	3	4	5	6	7	8	9	10	11	12	13	14	15	16	17	18	19	20	21	22	23	24	25	26	27	28	29	30	31	32	33	34	35	36	
43693-0001	IOAC	10	CS	CS	CM	CS	CS	CS	CS	CM	CS	CS	-	-	-	-	-	-	-	-	-	-	-	-	-	-	-	-	-	-	-	-	-	-	-	-	-	-	.283 (7.20)
43693-0002	24BA	24	AM	AM	AM	AM	AM	AM	AM	AM	AM	AM	AM	AM	AM	AM	AM	AS	AM	AM	AM	AM	AM	AM	AM	AM	-	-	-	-	-	-	-	-	-	-	-	-	.154 (3.91)
43693-0005	I6BA	16	AS	AS	AS	AS	AS	AS	AS	AS	AS	AS	AS	AS	AS	AS	-	-	-	-	-	-	-	-	-	-	-	-	-	-	-	-	-	-	-	-	-	.150 (3.81)	
43693-0020	I8BA	18	AS	AS	AS	AS	AS	AS	AS	AS	AS	AS	AS	AS	AS	AS	AS	AS	AS	-	-	-	-	-	-	-	-	-	-	-	-	-	-	-	-	-	-	.209 (5.31)	
43693-0022	IOBA	10	AS	AM	AM	AM	AM	AM	AM	AM	AM	AM	-	-	-	-	-	-	-	-	-	-	-	-	-	-	-	-	-	-	-	-	-	-	-	-	-	.321 (8.15)	
43693-0024	IOBC	10	CS	CS	CM	CS	CS	CM	CM	CM	CS	CS	-	-	-	-	-	-	-	-	-	-	-	-	-	-	-	-	-	-	-	-	-	-	-	-	-	.258 (6.55)	
43693-0027	I8BA	18	AS	AM	AM	AM	AM	AM	AM	AM	AM	AM	AM	AM	AM	AM	AM	AM	AS	-	-	-	-	-	-	-	-	-	-	-	-	-	-	-	-	-	-	.283 (7.20)	
43693-0030	I8BA	18	AS	AS	AS	AS	AS	AS	AS	AS	AS	AS	AS	AS	AS	AS	AS	AS	AS	-	-	-	-	-	-	-	-	-	-	-	-	-	-	-	-	-	-	.154 (3.91)	
43693-0031	I8BA	18	AM	AM	AM	AM	AM	AM	AM	AM	AM	AM	AM	AM	AM	AM	AM	AM	AM	-	-	-	-	-	-	-	-	-	-	-	-	-	-	-	-	-	-	.154 (3.91)	
43693-0037	18BD	18	DS	DM	DM	DM	DM	DM	DM	DM	DM	DM	DM	DM	DM	DM	DM	DM	DM	-	-	-	-	-	-	-	-	-	-	-	-	-	-	-	-	-	-	.258 (6.55)	

X = NOT AVAILABLE SEE NOTE 10

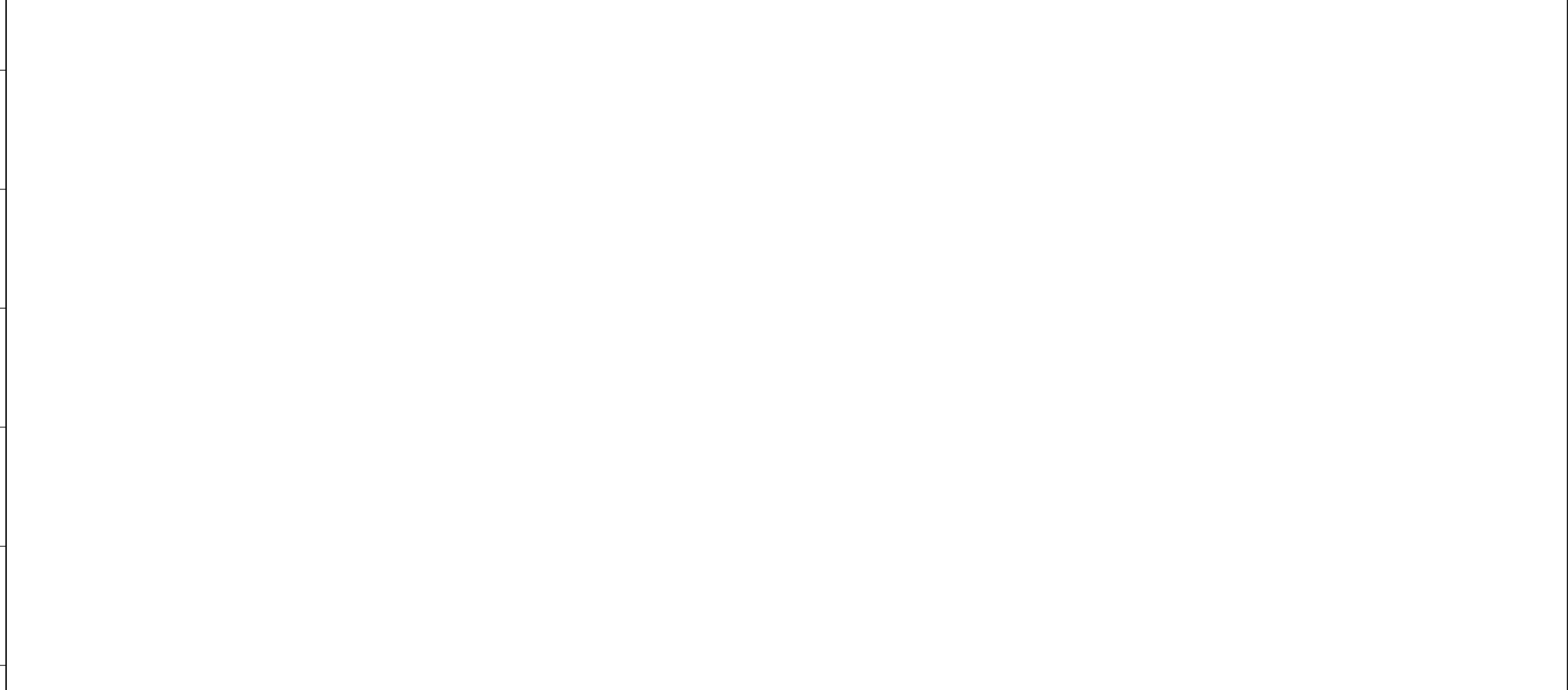

**CHARACTERISTICS LEGEND:**

**TERMINAL PLATING (SEE NOTE 2)**

CIRCUIT SIZE  $\frac{**}{*}$   $\frac{*}{*}$   
(02-24 & 36)

HOUSING MAT'L. (SEE NOTE 1)  
 \*A\* = NYLON 6/6, U.L. 94V-2,  
 COLOR: NATURAL  
 \*B\* = NYLON 6/6, U.L. 94V-0,  
 COLOR: NATURAL  
 \*C\* = PBT POLYESTER 94V-0,  
 COLOR: BLACK

A = MATTE TIN  
 C = SELECT GOLD  
 D = REFLOW MATTE TIN

SEE SHEET 1 EC NO: UCP2015-4258 DRWN: MONTI 2015/06/25 CHKD: J.BELL 2015/06/25 APPR: F.SMITH 2015/07/10	QUALITY SYMBOLS	GENERAL TOLERANCES (UNLESS SPECIFIED)	DIMENSION STYLE	SCALE	DESIGN UNITS	THIRD ANGLE PROJECTION
	▽=0 ▽=0 ▽=0	mm INCH	IN/MM		METRIC	

DRAWN BY	DATE	TITLE
GEP	3/11/96	VERT. HEADER ASSY WITH MAKE-FIRST/BREAK-LAST MINI-FIT B.M.I. SERIES
CHECKED BY	DATE	
RFJ	3/11/96	
APPROVED BY	DATE	
RFJ	3/11/96	
MATERIAL NO. SEE CHART		
DRAFT WHERE APPLICABLE MUST REMAIN WITHIN DIMENSIONS		
SIZE	THIS DRAWING CONTAINS INFORMATION THAT IS PROPRIETARY TO MOLEX INCORPORATED AND SHOULD NOT BE USED WITHOUT WRITTEN PERMISSION	
C		

DRAWN BY	DATE	TITLE
GEP	3/11/96	VERT. HEADER ASSY WITH MAKE-FIRST/BREAK-LAST MINI-FIT B.M.I. SERIES
CHECKED BY	DATE	
RFJ	3/11/96	
APPROVED BY	DATE	
RFJ	3/11/96	
MATERIAL NO. SEE CHART		
DRAFT WHERE APPLICABLE MUST REMAIN WITHIN DIMENSIONS		
SIZE	THIS DRAWING CONTAINS INFORMATION THAT IS PROPRIETARY TO MOLEX INCORPORATED AND SHOULD NOT BE USED WITHOUT WRITTEN PERMISSION	
C		

MOLEX INCORPORATED		SHEET NO.
DOCUMENT NO. SDA-43693-****		2 OF 2

## X-ON Electronics

Largest Supplier of Electrical and Electronic Components

*Click to view similar products for [Headers & Wire Housings](#) category:*

*Click to view products by [Molex](#) manufacturer:*

Other Similar products are found below :

[892-18-020-10-001101](#) [58102-G61-06LF](#) [582553-1](#) [0009485154](#) [009176003701906](#) [0050291907](#) [LY20-4P-DT1-P1E-BR](#) [02.125.8002.8](#)  
[609-3404](#) [61062-3](#) [622-0430](#) [622-3653LF](#) [63453-116](#) [636-1030](#) [636-1427](#) [636-3427](#) [636-4007](#) [641938-9](#) [641991-4](#) [644827-2](#) [65817-010LF](#)  
[65817-015LF](#) [65863-015LF](#) [66207-023LF](#) [67095-007LF](#) [67601157](#) [68648-049](#) [70.362.1628.0](#) [70-4210](#) [70-4226B](#) [70-4853B](#) [707-5020](#) [707-5028](#) [71.350.2428.0](#) [71918-208LF](#) [71961-016LF](#) [733-134](#) [733-162](#) [754199-000](#) [760-3052](#) [787-8014-00](#) [79531-3000](#) [FCN-360C032-B](#) [FCN-367T-T012/H](#) [FCN-723D010/2](#) [80.063.4001.1](#) [800-90-001-10-001000](#) [800-90-010-10-002000](#) [801-43-002-10-013000](#) [801-43-006-10-002000](#)