

CIRCUIT SIZE	DIM. "A"	DIM. "B"	DIM. "C"	DIM. "D"
2	.606 (15.40)	N.A.	.213 (5.40)	.354 (9.00)
4	.772 (19.60)	.165 (4.20)	.378 (9.60)	.520 (13.20)
6	.937 (23.80)	.331 (8.40)	.543 (13.80)	.685 (17.40)
8	1.102 (28.00)	.496 (12.60)	.709 (18.00)	.850 (21.60)
10	1.268 (32.20)	.661 (16.80)	.874 (22.20)	1.016 (25.80)
12	1.433 (36.40)	.827 (21.00)	1.039 (26.40)	1.181 (30.00)
14	1.598 (40.60)	.992 (25.20)	1.205 (30.60)	1.346 (34.20)
16	1.764 (44.80)	1.157 (29.40)	1.370 (34.80)	1.512 (38.40)
18	1.929 (49.00)	1.323 (33.60)	1.535 (39.00)	1.677 (42.60)
20	2.094 (53.20)	1.488 (37.80)	1.701 (43.20)	1.843 (46.80)
22	2.260 (57.40)	1.654 (42.00)	1.866 (47.40)	2.008 (51.00)
24	2.425 (61.60)	1.819 (46.20)	2.031 (51.60)	2.173 (55.20)

- NOTES:
- 1) MATERIALS:  
HOUSING MATERIAL OPTIONS: SEE CHART FOR SPECIFIC PART  
 NYLON, UNFILLED, UL94V-2, COLOR: NATURAL  
 NYLON, UNFILLED, UL94V-2, COLOR: BLACK  
 NYLON, UNFILLED, UL94V-0, COLOR: NATURAL  
 NYLON, UNFILLED, UL94V-0, COLOR: BLACK  
 LCP GLASS FILLED, UL94V-0, COLOR: BLACK  
 IEC 60335-1, 5TH EDITION GLOW WIRE CAPABLE,  
 WITH PRESS FIT PEG -SEE SHEET 3  
 TERMINALS: BRASS
  - 2) FINISH (PLATING) OPTIONS: SEE CHART FOR SPECIFIC PART  
 "GS" = 0.00076/(.000030) MIN. SELECT GOLD AND  
 0.00254/(.0000100) SELECT MATTE TIN OVER  
 0.00127/(.000050) MIN. NICKEL  
 "MS" = 0.00254/(.000100) MIN. MATTE TIN OVER  
 0.00127/(.000050) MIN. NICKEL
  - 3) PRODUCT SPECIFICATION: PS-5556-004 FOR LCP GLASS FILLED MATERIAL,  
 PS-5556-001 FOR ALL OTHER MATERIALS.
  - 4) PACKAGING: SEE CHART: BULK PER PK-5569-002  
 TRAY PER PK-5569-003(PEGGED) OR PK-5569-004(FLANGES)
  - 5) CIRCUITS SHOWN PROVIDE THE MAKE-FIRST/BREAK-LAST FEATURE.  
 SEE CHARTS ON SHEETS 3 & 4 FOR SPECIFIC CIRCUIT LOCATIONS.
  - 6) PART MATES WITH MINI-FIT JR. RECEPTACLE #5557.
  - 7) CONNECTORS ARE NOT TO BE MATED OR UNMATED WHILE CIRCUITS ARE LIVE.
  - 8) PARTS ARE NOT DESIGNED FOR CURRENT SHARING.
  - 9) DISCOLORATION IN THE BANDOLIER CARRIER AREA OF THE PIN IS INHERENT TO  
 THE PLATING PROCESS AND IS DUE TO THE MASKING EFFECT OF THE CARRIER.  
 THIS DISCOLORATION, IF PRESENT, IS IN A NON-FUNCTIONAL AREA OF THE PIN  
 AND WILL NOT EFFECT THE PERFORMANCE OF THE HEADER ASSEMBLY.
  - 10) PART CONFORMS TO CLASS "B" REQUIREMENTS OF COSMETIC SPECIFICATION  
 PS-45499-002.
  - 11) FORMING MARKS ARE ACCEPTABLE.
  - 12) CORNER CORE-OUTS ARE OPTIONAL AND MAY OR MAY NOT BE PRESENT.
  - 13) TEXT ON PART IS FOR REFERENCE ONLY. TEXT AND TEXT LOCATION MAY VARY  
 DEPENDING ON PART NUMBER AND/OR TOOL.

THIS DRAWING CONTAINS INFORMATION THAT IS PROPRIETARY TO MOLEX ELECTRONIC TECHNOLOGIES, LLC AND SHOULD NOT BE USED WITHOUT WRITTEN PERMISSION

SYMBOLS	DIMENSION UNITS	SCALE	CURRENT REV / DESC: ADD P/N 44130-0048		
	IN/MM	4:1			
▽ = 0 ▽ = 0 ▽ = 0 ▽ = 0 ▽ = 0 ▽ = 0 ▽ = 0 ▽ = 0 ▽ = 0 ▽ = 0 ▽ = 0 ▽ = 0 ▽ = 0	GENERAL TOLERANCES (UNLESS SPECIFIED)		EC NO: 626690		
	4 PLACES	±	±	DRWN: DSTEIER	2019/11/01
	3 PLACES	±	± 0.015	CHK'D: MKIPPER	2019/11/19
	2 PLACES	± 0.38	± 0.015	APPR: FSMITH	2019/12/02
	1 PLACE	± 0.38	±	INITIAL REVISION:	
0 PLACES	±	±	DRWN: POLGAR	1998/01/23	
ANGULAR TOL ± 0.5°		APPR: FSMITH		2011/05/18	
DRAFT WHERE APPLICABLE MUST REMAIN WITHIN DIMENSIONS		THIRD ANGLE PROJECTION	DRAWING	SERIES	MATERIAL NUMBER
			C-SIZE	44130	SEE CHART
					CUSTOMER
					GENERAL MARKET
					SHEET NUMBER
					1 OF 5

DOCUMENT NUMBER: SD-44130-001  
 DOC TYPE: PSD  
 DOC PART: 000  
 REVISION: E16

# HOUSING WITH PEGS

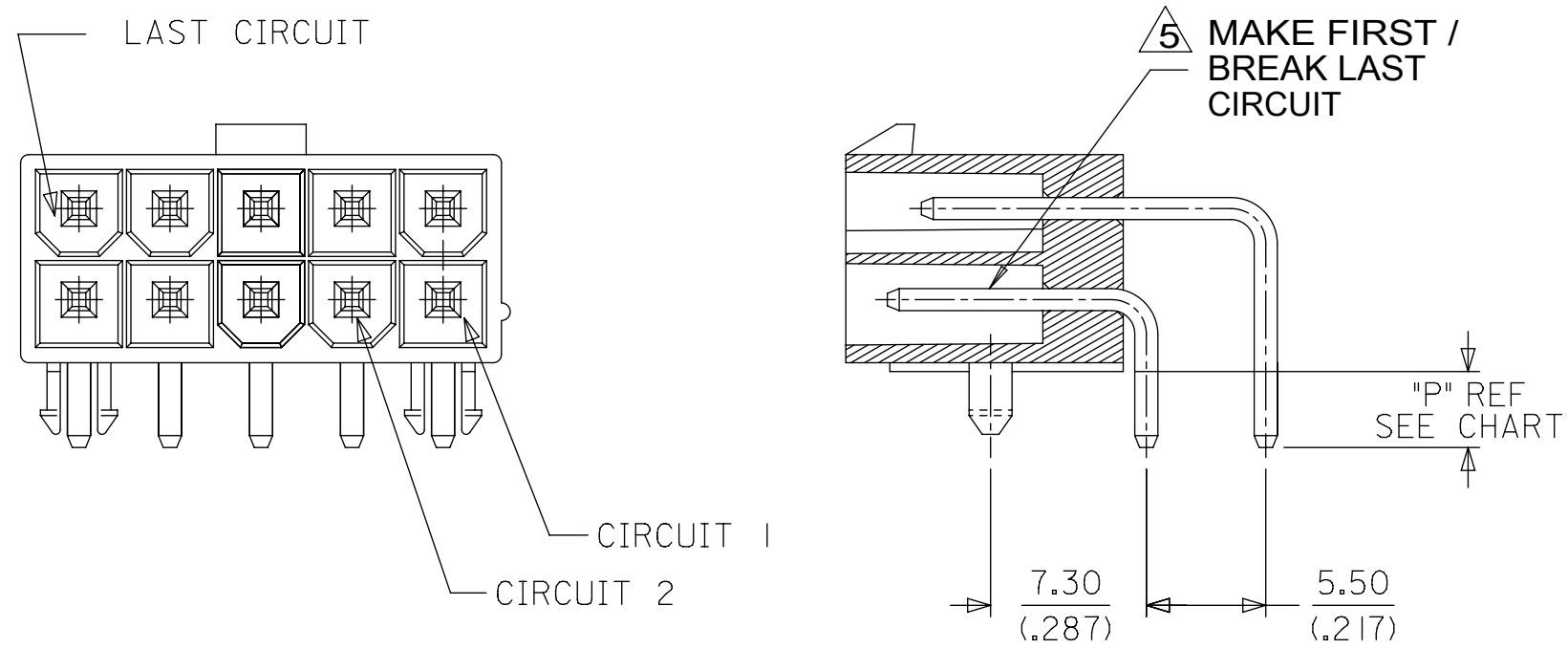

# HOUSING WITH FLANGE

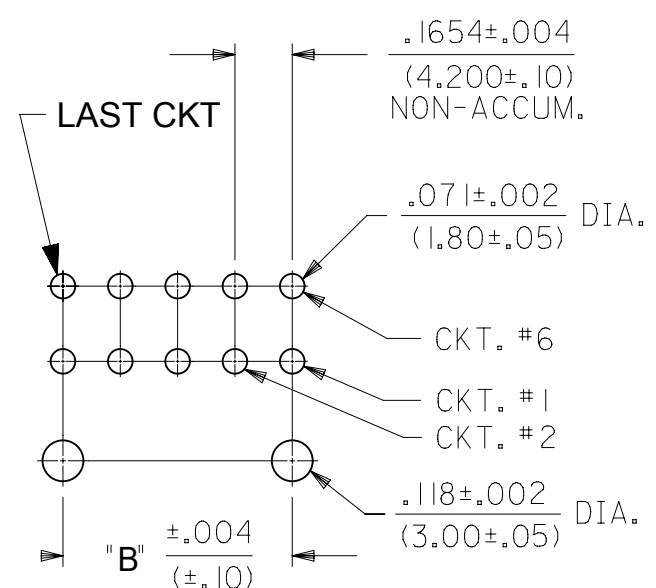
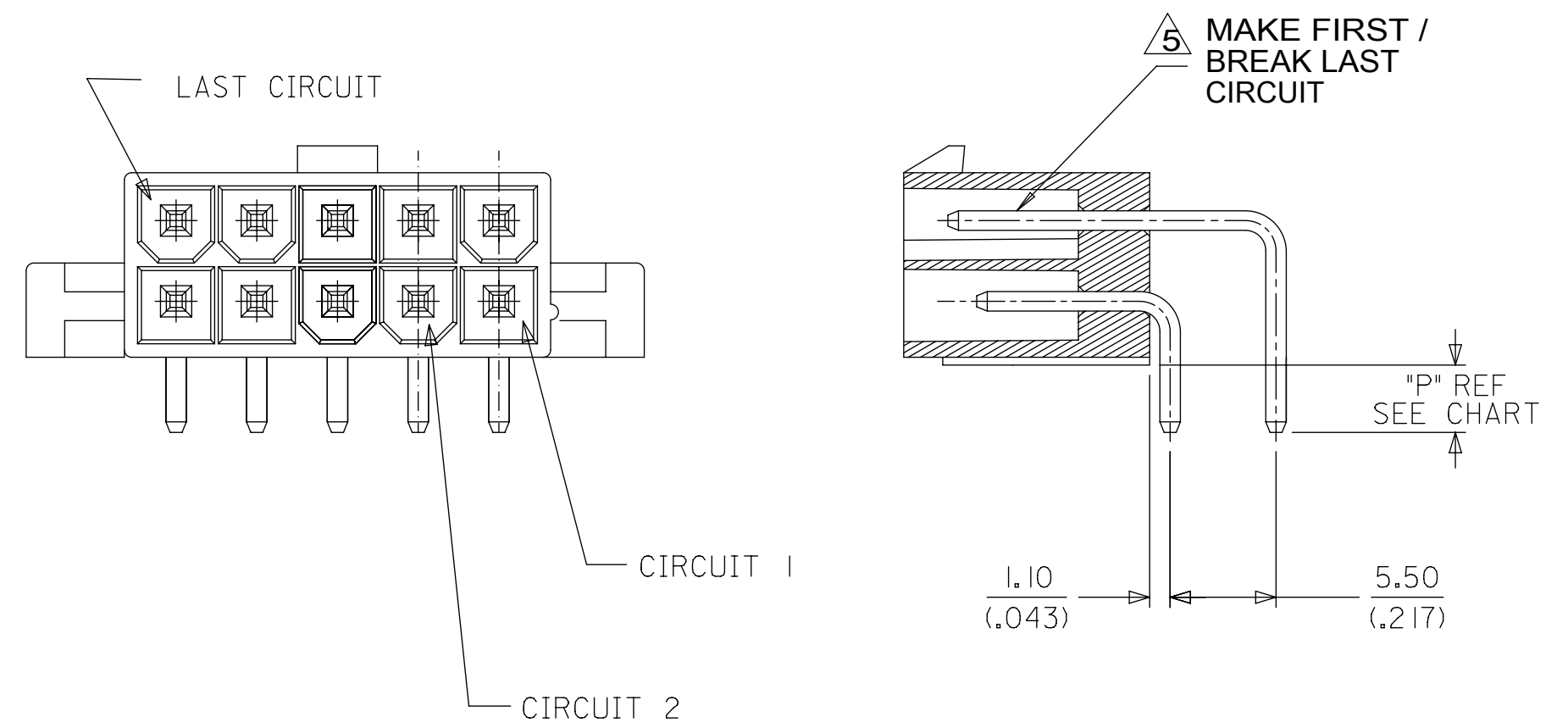

RECOMMENDED HOLE LAYOUT FOR .070/(1.78) MAX. THICK P.C. BOARD VIEWED FROM COMPONENT SIDE FOR 6 THRU 24 CIRCUITS

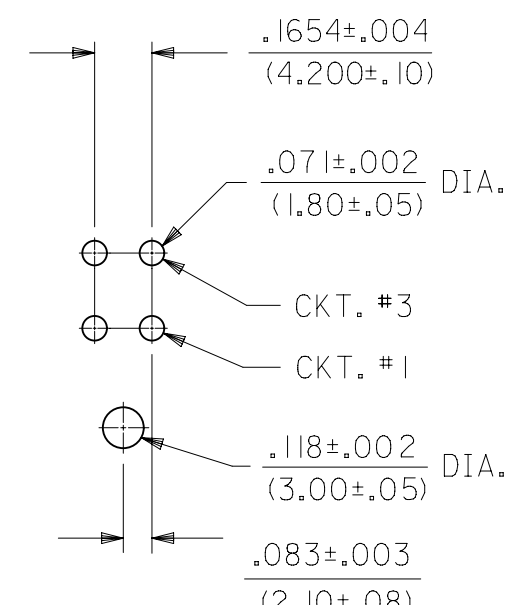

RECOMMENDED HOLE LAYOUT FOR .070/(1.78) MAX. THICK P.C. BOARD VIEWED FROM COMPONENT SIDE FOR 4 CIRCUIT PARTS

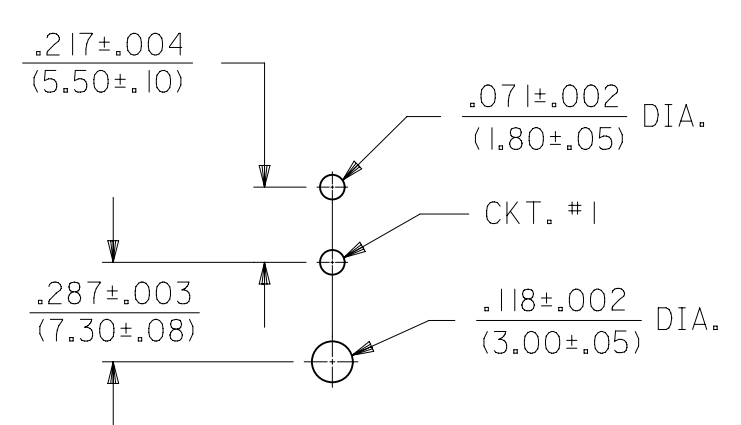

RECOMMENDED HOLE LAYOUT FOR .070/(1.78) MAX. THICK P.C. BOARD VIEWED FROM COMPONENT SIDE FOR 2 CIRCUIT PARTS

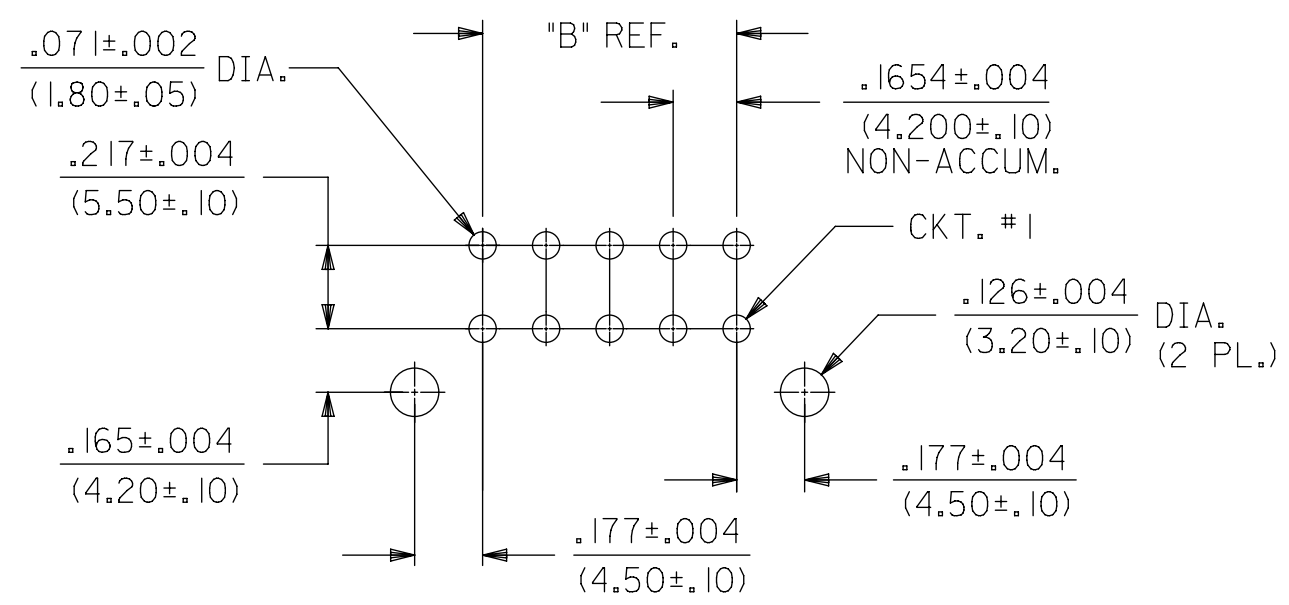

RECOMMENDED HOLE LAYOUT FOR .070/(1.78) MAX. THICK P.C. BOARD. (FLANGE MOUNT)

SYMBOLS	THIS DRAWING CONTAINS INFORMATION THAT IS PROPRIETARY TO MOLEX ELECTRONIC TECHNOLOGIES, LLC AND SHOULD NOT BE USED WITHOUT WRITTEN PERMISSION											
	DIMENSION UNITS		SCALE		CURRENT REV DESC: ADD P/N 44130-0048							
▽ = 0	IN/MM		4:1		EC NO: 626690 DRWN: DSTEIER 2019/11/01 CHK'D: MKIPPER 2019/11/19 APPR: FSMITH 2019/12/02 INITIAL REVISION: DRWN: POLGAR 1998/01/23 APPR: FSMITH 2011/05/18							
▽ = 0	GENERAL TOLERANCES (UNLESS SPECIFIED)											
▽ = 0		MM	INCH		MINI-FIT JR RIGHT ANGLE HEADER ASSY CUSTOM HEADERS PRODUCT CUSTOMER DRAWING							
▽ = 0	4 PLACES	±	±									
▽ = 0	3 PLACES	±	± 0.015		DOCUMENT NUMBER: SD-44130-001 DOC TYPE: PSD DOC PART: 000 REVISION: E16							
▽ = 0	2 PLACES	± 0.38	± 0.015									
▽ = 0	1 PLACE	± 0.38	±		MATERIAL NUMBER: SEE CHART CUSTOMER: GENERAL MARKET SHEET NUMBER: 2 OF 5							
▽ = 0	0 PLACES	±	±									
▽ = 0	ANGULAR TOL		± 0.5 °		THIRD ANGLE PROJECTION		DRAWING		SERIES			
▽ = 0	DRAFT WHERE APPLICABLE MUST REMAIN WITHIN DIMENSIONS				C-SIZE		44130					

# HOUSING WITH PRESS FIT PEGS

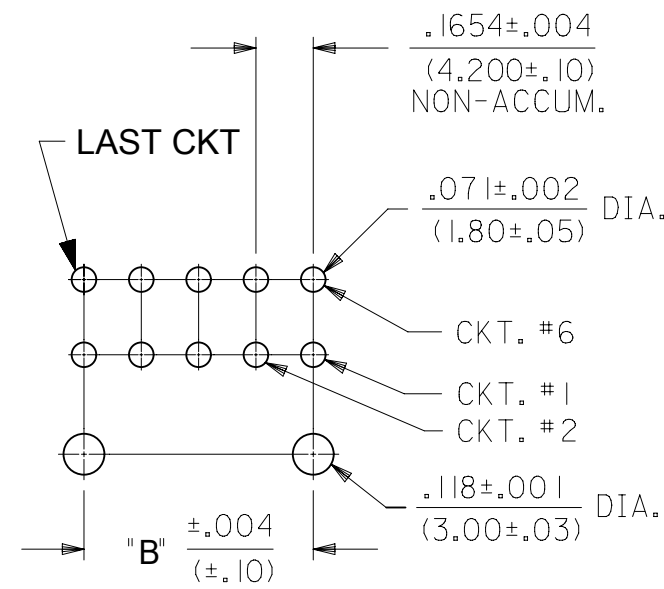
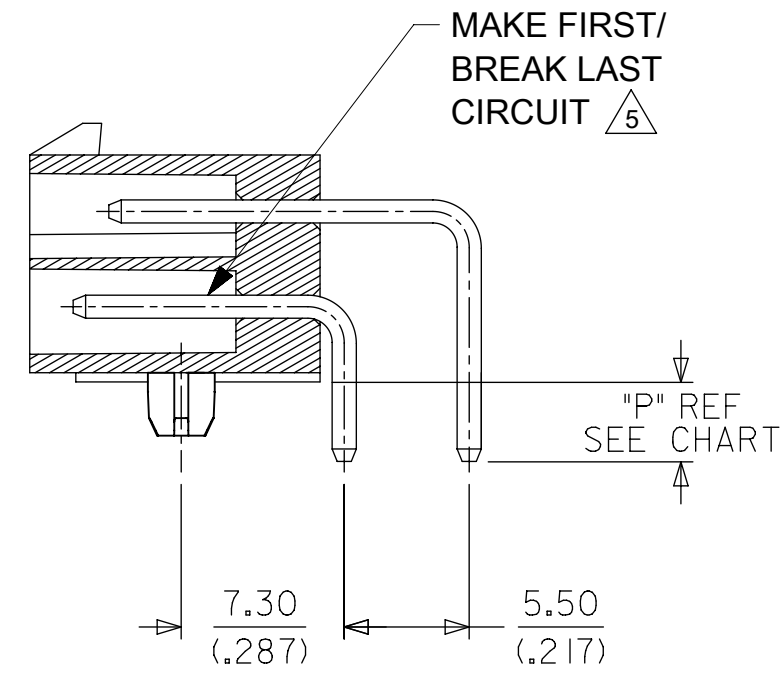
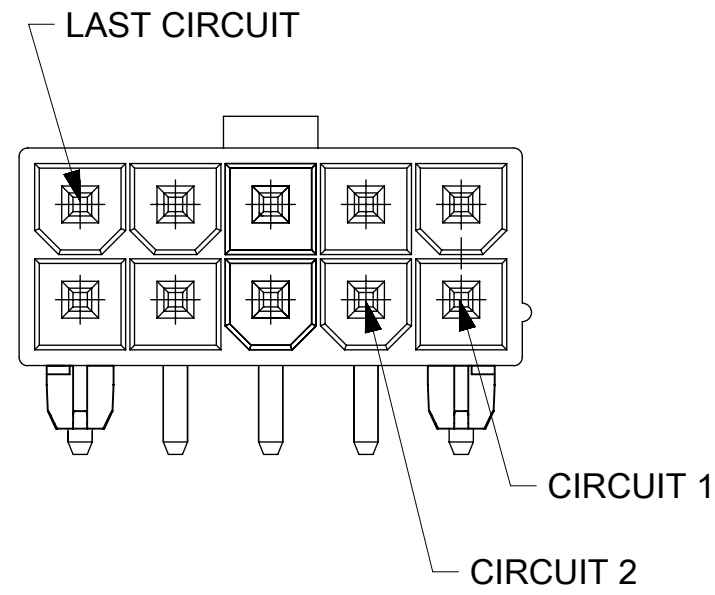

RECOMMENDED HOLE LAYOUT FOR .070/(1.78) MAX. THICK P.C. BOARD VIEWED FROM COMPONENT SIDE FOR 6 THRU 24 CIRCUITS

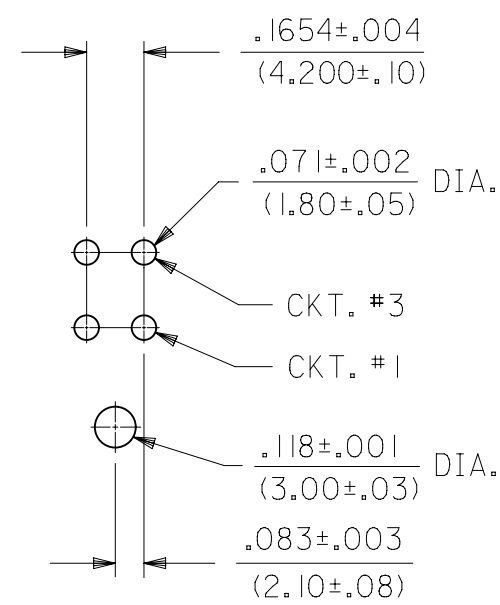

RECOMMENDED HOLE LAYOUT FOR .070/(1.78) MAX. THICK P.C. BOARD VIEWED FROM COMPONENT SIDE FOR 4 CIRCUIT PARTS

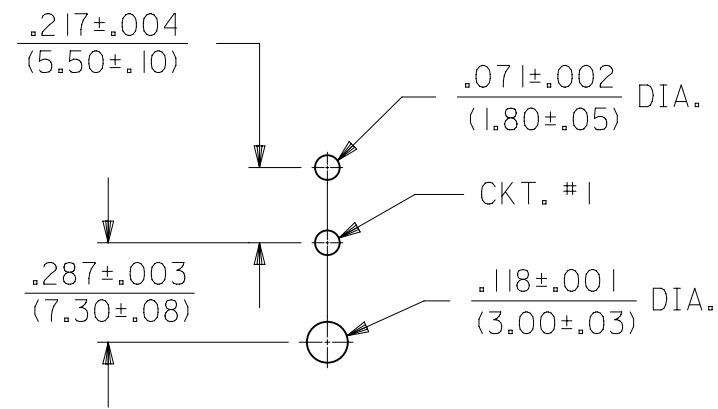

RECOMMENDED HOLE LAYOUT FOR .070/(1.78) MAX. THICK P.C. BOARD VIEWED FROM COMPONENT SIDE FOR 2 CIRCUIT PARTS

SYMBOLS	THIS DRAWING CONTAINS INFORMATION THAT IS PROPRIETARY TO MOLEX ELECTRONIC TECHNOLOGIES, LLC AND SHOULD NOT BE USED WITHOUT WRITTEN PERMISSION									
	DIMENSION UNITS		SCALE		CURRENT REV DESC: ADD P/N 44130-0048					
∇ = 0	IN/MM		4:1		<b>molex</b> MINI-FIT JR RIGHT ANGLE HEADER ASSY CUSTOM HEADERS					
∇ = 0	GENERAL TOLERANCES (UNLESS SPECIFIED)									
∇ = 0			MM	INCH	EC NO: 626690 DRWN: DSTEIER 2019/11/01 CHK'D: MKIPPER 2019/11/19 APPR: FSMITH 2019/12/02					
S = 0	4 PLACES	±	±	±						
∇ = 0	3 PLACES	±	±	0.015	INITIAL REVISION: DRWN: DRWN BY XXXX/XX/XX APPR: APPR BY XXXX/XX/XX					
∇ = 0	2 PLACES	±	0.38	±						
∇ = 0	1 PLACE	±	0.38	±	PRODUCT CUSTOMER DRAWING DOCUMENT NUMBER: SD-44130-001 DOC TYPE: PSD DOC PART: 000 REVISION: E16					
∇ = 0	0 PLACES	±	±	±						
∇ = 0	ANGULAR TOL ± 0.5°		THIRD ANGLE PROJECTION		DRAWING		SERIES			
∇ = 0	DRAFT WHERE APPLICABLE MUST REMAIN WITHIN DIMENSIONS		C-SIZE		44130			GENERAL MARKET		
∇ = 0							SHEET NUMBER: 3 OF 5			

MATERIAL NUMBER	HOUSING MAT'L/COLOR	NO OF CKT	HOUSING OPTION	PKG	FINISH SEE NOTE #2	PIN IDENTIFICATION CODE / CIRCUIT LOCATION (SEE CHART BELOW) V = VOID																							
						CKT 1	CKT 2	CKT 3	CKT 4	CKT 5	CKT 6	CKT 7	CKT 8	CKT 9	CKT 10	CKT 11	CKT 12	CKT 13	CKT 14	CKT 15	CKT 16	CKT 17	CKT 18	CKT 19	CKT 20	CKT 21	CKT 22	CKT 23	CKT 24
44130-0001	NYLON 94V-2/BLACK	06	PEG	TRAY	MS					2																			
44130-0002	NYLON 94V-2/BLACK	08	PEG	TRAY	MS	2																							
44130-0003	NYLON 94V-0/BLACK	08	PEG	TRAY	MS	2																							
44130-0004	NYLON 94V-0/BLACK	06	PEG	TRAY	MS					2																			
44130-0006	NYLON 94V-0/NATURAL	04	PEG	BULK	MS	2	3	2	2																				
44130-0007	NYLON 94V-0/NATURAL	06	PEG	BULK	MS	2			2	2	2																		
44130-0008	NYLON 94V-0/NATURAL	10	FLANGES	BULK	MS	4	4	4	4	4	4	4	4	4	4														
44130-0009	NYLON 94V-0/NATURAL	06	PEG	TRAY	MS	V			2	2	2																		
44130-0013	NYLON 94V-0/NATURAL	06	FLANGES	TRAY	MS	2	2	2		2	2																		
44130-0015	NYLON 94V-2/NATURAL	24	PEG	TRAY	MS	2	2																			2			
44130-0017	NYLON 94V-0/BLACK	08	PEG	TRAY	MS		2																						
44130-0024	NYLON 94V-0/NATURAL	08	PEG	BULK	GS	2	2	5	2	2	5	2	2																
44130-0026	NYLON 94V-2/NATURAL	04	PEG	BULK	MS	8	8	8	8																				
44130-0027	NYLON 94V-0/NATURAL	02	PEG	BULK	MS	5	5																						
44130-0028	NYLON 94V-0/NATURAL	04	PEG	BULK	MS	8	8	8	8																				
44130-0030	NYLON 94V-0/NATURAL	06	PEG	TRAY	GS	2	1	2	2	2	2																		
44130-0031	NYLON 94V-0/NATURAL	08	PEG	BULK	MS	9	9	9	9	9	9	9																	

PIN ID	MATING CONFIGURATION	DIM P REF (PCB TAIL LENGTH)	PIN ID	MATING CONFIGURATION	DIM P (PCB TAIL LENGTH)
2	STANDARD MATING	3.5 (.14)			
3	MAKE FIRST/BREAK LAST (LONGER PIN)	4.9 (.19)			
4	STANDARD MATING	6.0 (.24)			
5	MAKE FIRST/BREAK LAST (LONGER PIN)	4.2 (.17)			
6	STANDARD MATING	4.2 (.17)			
8	STANDARD MATING	5.3 (.21)			

<b>SYMBOLS</b> = 0 = 0 = 0 = 0 = 0 = 0 = 0 = 0 = 0 = 0	THIS DRAWING CONTAINS INFORMATION THAT IS PROPRIETARY TO MOLEX ELECTRONIC TECHNOLOGIES, LLC AND SHOULD NOT BE USED WITHOUT WRITTEN PERMISSION												
	DIMENSION UNITS		SCALE		CURRENT REV DESC: ADD P/N 44130-0048								
	IN/MM		1:1		<b>molex</b> MINI-FIT JR RIGHT ANGLE HEADER ASSY CUSTOM HEADERS PRODUCT CUSTOMER DRAWING								
	GENERAL TOLERANCES (UNLESS SPECIFIED)												
	4 PLACES ±		MM		INCH		EC NO: 626690 DRWN: DSTEIER 2019/11/01 CHK'D: MKIPPER 2019/11/19 APPR: FSMITH 2019/12/02						
	3 PLACES ±		± 0.015		INITIAL REVISION: DRWN: POLGAR 1998/01/23 APPR: FSMITH 2011/05/18								
	2 PLACES ±		± 0.38 ± 0.015										
	1 PLACE ±		± 0.38 ±		DOCUMENT NUMBER: SD-44130-001 DOC TYPE: PSD DOC PART: 000 REVISION: E16								
	0 PLACES ±		±										
	ANGULAR TOL ± 0.5 °		THIRD ANGLE PROJECTION		DRAWING		SERIES		MATERIAL NUMBER		CUSTOMER		SHEET NUMBER
DRAFT WHERE APPLICABLE MUST REMAIN WITHIN DIMENSIONS				C-SIZE		44130		SEE CHART		GENERAL MARKET		4 OF 5	



## X-ON Electronics

Largest Supplier of Electrical and Electronic Components

*Click to view similar products for [Headers & Wire Housings](#) category:*

*Click to view products by [Molex](#) manufacturer:*

Other Similar products are found below :

[95000-104TRLF](#) [10135584-644402LF](#) [DF62W-EP2022PCA](#) [95000-106TRLF](#) [DF62W-2022SCA](#) [DF62W-EP2022PC](#) [2203348](#) [DF62W-2022SC](#) [1084018](#) [1029039](#) [1084017](#) [802-10-012-10-002000](#) [1112640](#) [1112639](#) [891-007-9SS-BST1T](#) [000-34000](#) [0008550134](#) [0009482033](#) [0009507031](#) [57102-F02-18ULF](#) [57102-S06-03LF](#) [57202-S52-04LF](#) [PCN6-15S-2.5E](#) [0039019024](#) [58102-G61-06LF](#) [582553-1](#) [0009485154](#) [0009508121](#) [0022285053](#) [0050291907](#) [018731A](#) [LY20-4P-DT1-P1E-BR](#) [02.125.8002.8](#) [60101931](#) [60598-1 \(Cut Strip\)](#) [M1625-3R/100](#) [61062-3](#) [61082-181009](#) [CSU011177004](#) [636-1427](#) [638009-1](#) [641938-9](#) [641991-4](#) [644168-1](#) [644827-2](#) [647662-1](#) [65039-019ELF](#) [65692-001LF](#) [65781-018](#) [65781-047](#)