

CIRCUIT SIZE	DIM. "A"	DIM. "B"
2	—	—
4	.59 (15.0)	.165 (4.20)
6	.76 (19.2)	.331 (8.40)
8	.92 (23.4)	.496 (12.60)
10	1.09 (27.6)	.661 (16.80)
12	1.25 (31.8)	.827 (21.00)
14	1.42 (36.0)	.992 (25.20)
16	1.58 (40.2)	1.157 (29.40)
18	1.75 (44.4)	1.323 (33.60)
20	1.91 (48.6)	1.488 (37.80)
22	2.08 (52.8)	1.654 (42.00)
24	2.24 (57.0)	1.819 (46.20)

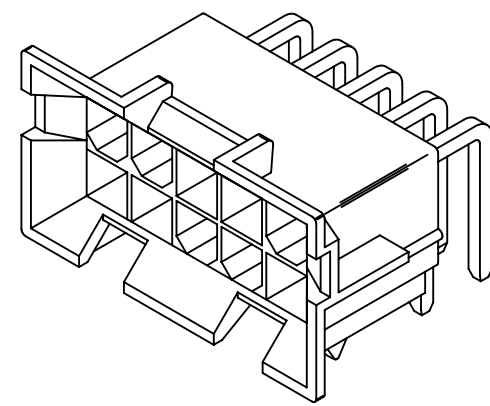

A-44499-*

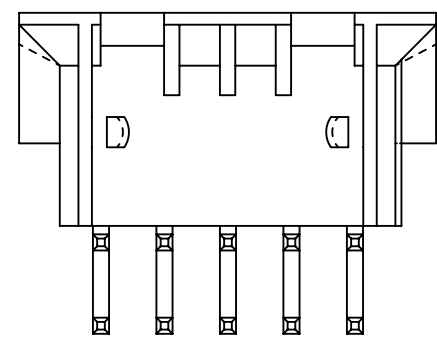
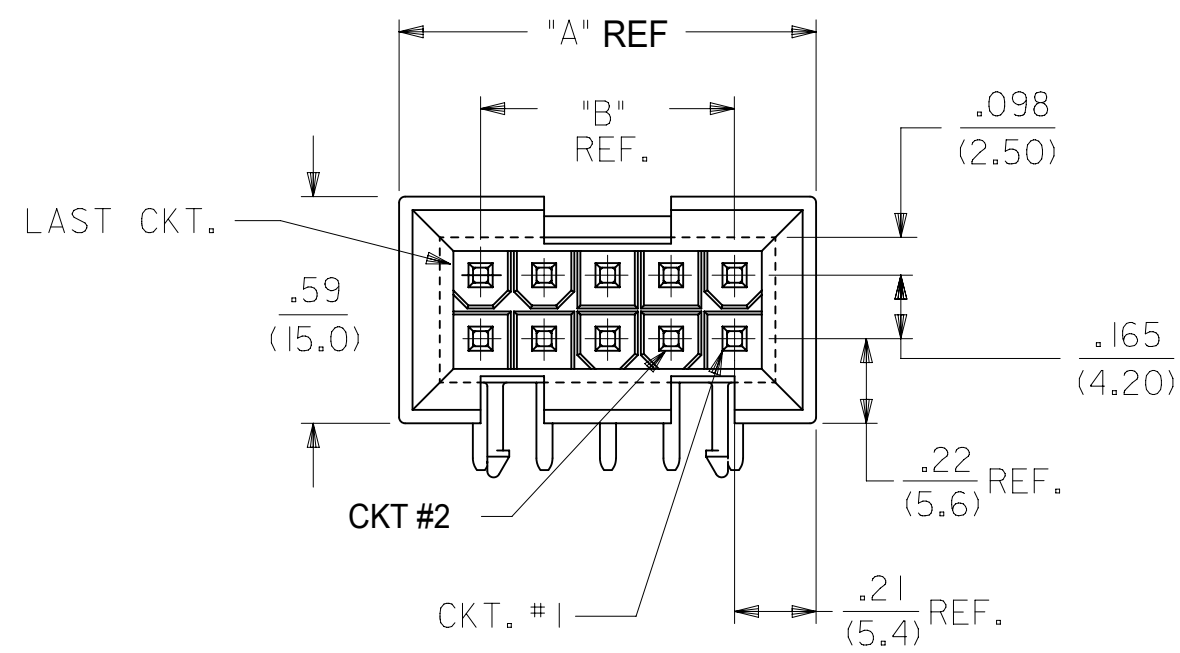
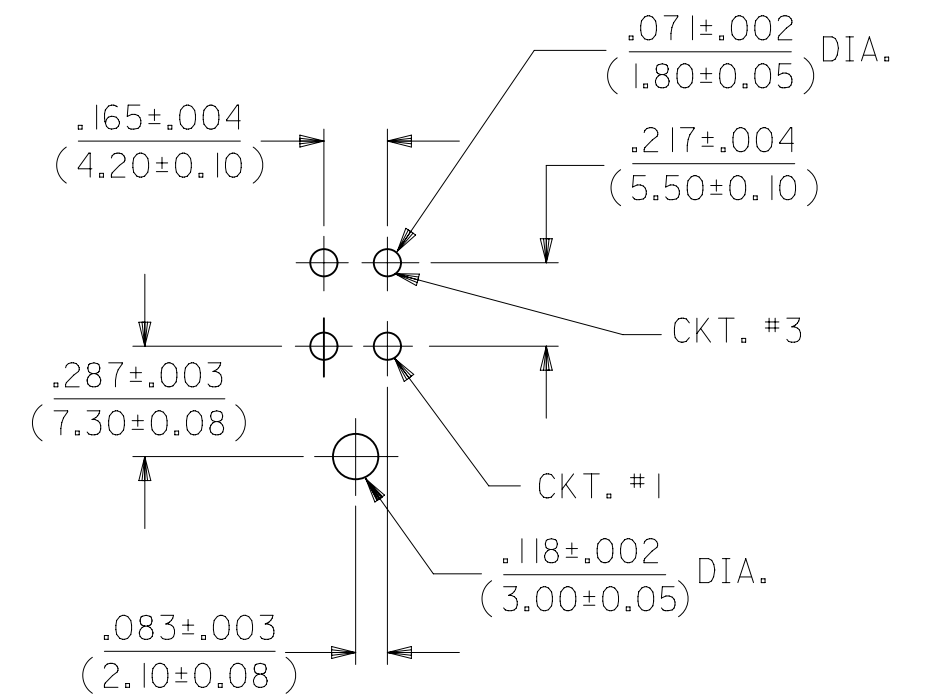
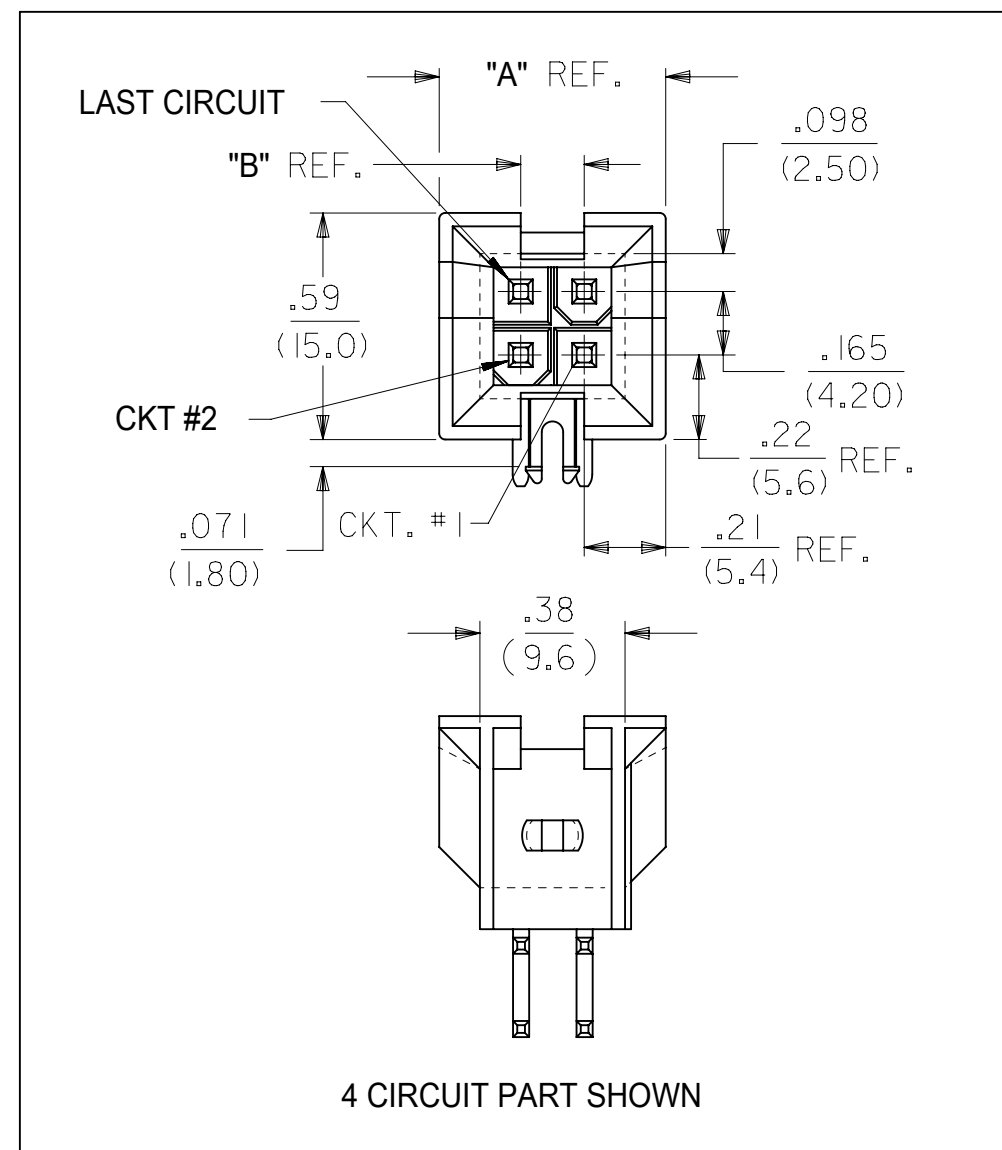
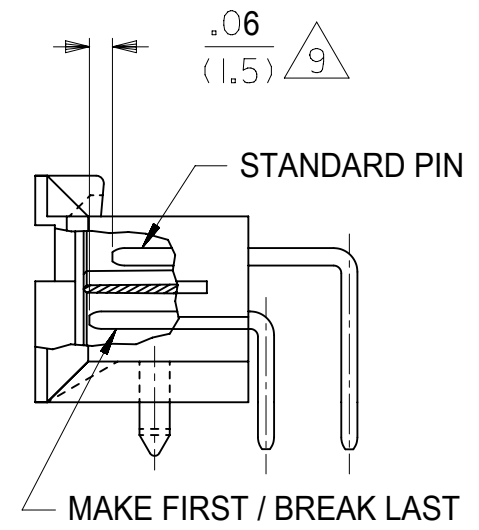
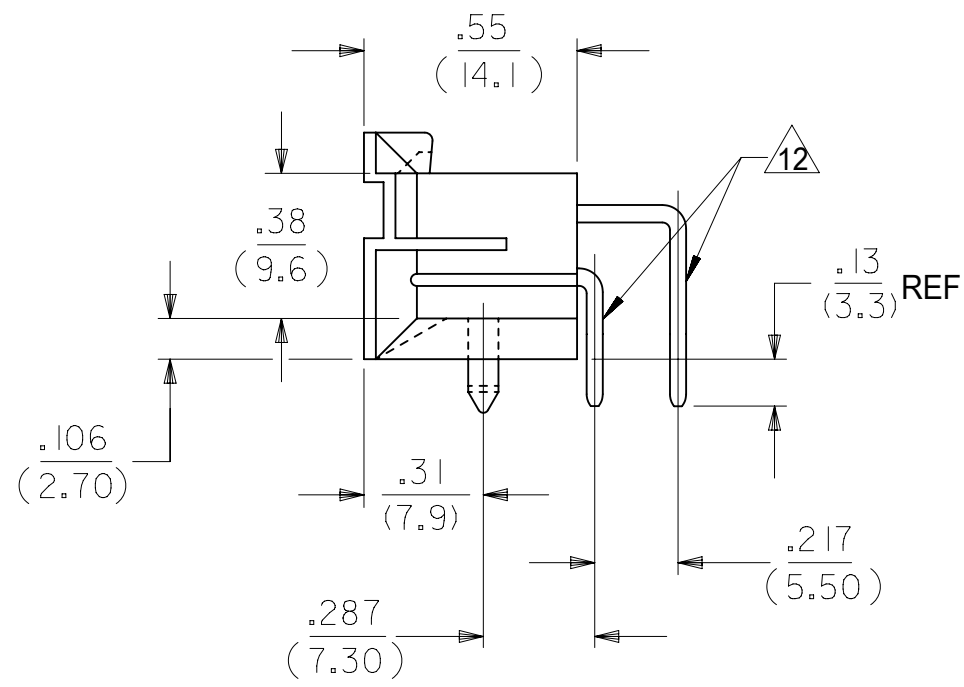

4 CIRCUIT PCB LAYOUT
RECOMMENDED HOLE LAYOUT FOR
.070/(1.78) MAX. THICK P.C. BOARD
VIEWED FROM COMPONENT SIDE

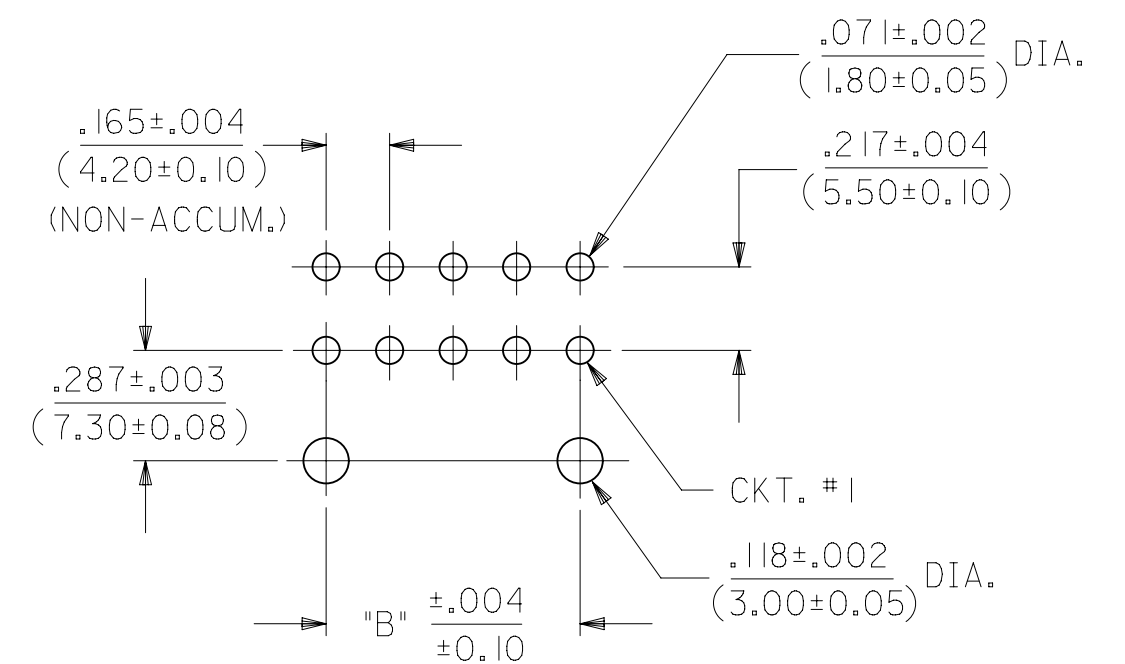

RECOMMENDED HOLE LAYOUT FOR
.070/(1.78) MAX. THICK P.C. BOARD
VIEWED FROM COMPONENT SIDE

NOTES:

- MATERIAL:
HOUSING: "A" = NYLON 6/6, UL 94V-2, COLOR: NATURAL
"B" = NYLON 6/6, UL 94V-0, COLOR: NATURAL
TERMINALS: BRASS
- TERMINAL PLATING:
C = .000030/(.00076) MIN. SELECT GOLD AND
.000100/(.00254) MIN. MATTE TIN OVER
.000050/(.00127) MIN. NICKEL OVERALL.
D = .000100/(.00254) MIN. MATTE TIN OVER
.000050/(.00127) MIN. NICKEL OVERALL.
- PRODUCT SPECIFICATION: PS-5556-002
- PACKAGING: TRAY PACKED PER MOLEX SPECIFICATION PK-42404-002.
- PART MATES WITH MINI-FIT JR. RECEPTACLE 5557, 42385, 42474 AND 44516. 2 CIRCUIT PARTS MATE WITH 42385, 42474, AND 44516 ONLY.
- PART ALLOWS FOR UP TO .100/(2.54) MISALIGNMENT WITH MATING RECEPTACLE IN ANY DIRECTION. SEE MATING CONNECTOR DRAWINGS FOR SPECIFIC ALLOWANCES.
- PART IS NOT DESIGNED FOR CURRENT SHARING.
- CONNECTOR ASSEMBLIES ARE NOT TO BE MATED OR UNMATED WHILE CIRCUITS ARE LIVE.
- CIRCUITS SHOWN PROVIDE THE "MAKE-FIRST/BREAK-LAST" FEATURE.
- PART CONFORMS TO CLASS B OF COSMETIC SPECIFICATION PS-45499-002.
- DISCOLORATION IN THE BANDOLIER CARRIER AREA OF THE PIN IS INHERENT TO THE PLATING PROCESS AND IS DUE TO THE MASKING EFFECT OF THE CARRIER. THIS DISCOLORATION IS IN A NON-FUNCTIONAL AREA OF THE PIN AND WILL NOT AFFECT THE PERFORMANCE OF THE HEADER ASSEMBLY.
- FORMING MARKS ARE ACCEPTABLE

THIS DRAWING
REPLACES SDA-44499-X

SYMBOLS		THIS DRAWING CONTAINS INFORMATION THAT IS PROPRIETARY TO MOLEX ELECTRONIC TECHNOLOGIES, LLC AND SHOULD NOT BE USED WITHOUT WRITTEN PERMISSION	
∇ = 0	INCH/MM	SCALE	CURRENT REV / DESC: ADDED PT. #444990132
∇ = 0	2:1	GENERAL TOLERANCES (UNLESS SPECIFIED)	
∇ = 0		MM	INCH
∇ = 0	4 PLACES ±		
∇ = 0	3 PLACES ±		
∇ = 0	2 PLACES ±	0.25	0.015
∇ = 0	1 PLACE ±	0.38	
∇ = 0	0 PLACES ±		
∇ = 0	ANGULAR TOL ±	0.5°	
∇ = 0	DRAFT WHERE APPLICABLE MUST REMAIN WITHIN DIMENSIONS	THIRD ANGLE PROJECTION	DRAWING SERIES
		C-SIZE	44499
		EC NO: 623458	DRWN: DSTEIER 2019/08/29
		CHK'D: JCOMERCI	2019/09/06
		APPR: JCOMERCI	2019/09/06
		INITIAL REVISION:	
		DRWN: DSTEIER	2019/08/29
		APPR: JCOMERCI	2019/09/06
		DOCUMENT NUMBER	DOC TYPE DOC PART REVISION
		444990000-SD	PSD 000 A
		MATERIAL NUMBER	CUSTOMER
		SEE CHART	
			SHEET NUMBER
			1 OF 3

ITEM NO.	CKT. SIZE	CHARACTERISTIC DESCRIPTION	LETTER INDICATES PIN PLATING AND LENGTH REQUIRED AT EACH CIRCUIT LOCATION. SEE NOTE 2 ON SHEET 1.																							
			1	2	3	4	5	6	7	8	9	10	11	12	13	14	15	16	17	18	19	20	21	22	23	24
44499-0005	24	24BC	CM	CM	CM	CM	CM	CM	CM	CM	CM	CM	CM	CM	CM	CM	CM	CM	CM	CM	CM	CM	CM	CM	CM	
44499-0006	04	04BC	CS	CM	CM	CS	-	-	-	-	-	-	-	-	-	-	-	-	-	-	-	-	-	-	-	
44499-0027	10	10BD	DS	DM	DM	DM	DM	DM	DM	DM	DM	DM	-	-	-	-	-	-	-	-	-	-	-	-	-	
44499-0029	24	24BD	DM	DM	DM	DM	DM	DM	DM	DM	DM	DM	DM	DM	DM	DM	DM	DM	DM	DM	DM	DM	DM	DM	DM	
44499-0036	24	24BD	DS	DS	DM	DM	DS	DS	DM	DS	DS	DS	DS	DS	DS	DM	DM	DM	DS	DS	DS	DS	DS	DM	DS	
44499-0041	14	14AD	DS	DS	DS	V	DS	DS	DS	DM	DS	DS	V	DS	DS	DM	-	-	-	-	-	-	-	-	-	
44499-0042	10	10BC	CS	CS	CS	CS	CS	CS	CS	CS	CS	CM	-	-	-	-	-	-	-	-	-	-	-	-	-	
44499-0049	24	24AD	DM	DM	DM	DM	DS	DS	DS	DS	DS	DS	DS	DS	DS	DS	DS	DS	DS	DS	DS	DS	DS	DS	DS	
44499-0055	10	10BC	CS	CM	CM	CM	CM	CM	CM	CM	CM	CM	-	-	-	-	-	-	-	-	-	-	-	-	-	
44499-0061	06	06BD	DM	DM	DM	DM	DM	DM	-	-	-	-	-	-	-	-	-	-	-	-	-	-	-	-	-	
44499-0065	24	24BC	CS	CM	CM	CM	CM	CM	CM	CM	CM	CM	CM	CM	CM	CM	DS	CM	CM	CM	CM	CM	CM	CM	CS	
44499-0066	18	18BD	DS	DS	DS	DS	DS	DS	DS	DS	DS	DS	DS	DS	DS	DM	DS	DS	DS	DM	-	-	-	-	-	
44499-0072	18	18BC	CS	CS	CS	CM	CM	CM	CM	CM	CS	CS	CM	CM	CM	CM	CM	CM	CS	-	-	-	-	-	-	
44499-0073	06	06BC	CS	CM	CM	CM	CM	CM	CM	-	-	-	-	-	-	-	-	-	-	-	-	-	-	-	-	
44499-0075	18	18AD	DM	DS	DS	DS	DS	DS	DS	DS	DS	DS	DS	DS	DS	DS	DS	DS	DM	-	-	-	-	-	-	
44499-0078	18	18BC	CS	CM	CM	CM	CM	CM	CM	CM	CM	CM	CM	CM	CM	CM	CM	CM	CM	CM	-	-	-	-	-	
44499-0089	10	10BC	CS	CS	CM	CS	CS	CM	CM	CM	CM	CS	-	-	-	-	-	-	-	-	-	-	-	-	-	
44499-0090	24	24BD	DS	DS	DM	DM	DM	DS	DS	DS	DS	DM	DS	DS	DS	DS	DM	DS	DS	DS	DS	DS	DM	DM	DS	
44499-0092	04	04BD	DS	DM	DM	DS	-	-	-	-	-	-	-	-	-	-	-	-	-	-	-	-	-	-	-	
44499-0093	04	04BC	CS	CM	CM	CS	-	-	-	-	-	-	-	-	-	-	-	-	-	-	-	-	-	-	-	
44499-0094	18	18BC	CM	CM	CM	CM	CM	CM	CM	CM	CM	CM	CM	CM	CM	CM	CM	CS	CM	-	-	-	-	-	-	
44499-0095	18	18BC	CM	CM	CM	CM	CM	CM	CM	CM	CM	CM	CS	CM	CM	CM	CM	CM	CM	CM	-	-	-	-	-	
44499-0096	24	24AD	DM	DM	V	DM	DM	V	DM	DM	DM	DM	DM	DM	DM	V	DM	DM	V	DM	DM	DM	DM	DM	DM	
44499-0097	14	14BC	CM	CM	CM	CM	CM	CM	CM	CM	CM	CM	CM	CM	CS	-	-	-	-	-	-	-	-	-	-	
44499-0099	24	24BC	CM	CM	CM	CM	CM	CM	CM	CM	CM	CM	CM	CM	CM	CM	CM	CM	CM	CM	CM	CM	CM	CM	CS	
44499-0100	24	24BC	CS	CM	CM	CM	CM	CM	CM	CM	CM	CM	CM	CM	CS	CM	CS	CM	CS	CM	CS	CM	CS	CM	CS	
44499-0101	14	14BC	CM	CS	CM	CM	CS	CM	CM	CM	CM	CM	CM	CM	CS	-	-	-	-	-	-	-	-	-	-	
44499-0102	24	24BC	CM	CM	CS	CS	CS	CS	CS	CS	CS	CS	CM	CM	CM	CM	CS	CS	CS	CS	CS	CS	CM	CM	CM	
44499-0103	24	24AD	DM	DS	DS	DS	DS	DS	DS	DS	DS	DS	DS	DS	DS	DS	DS	DS	DS	DS	DS	DS	DS	DS	DM	
44499-0104	24	24BC	CM	CS	CM	CS	CM	CS	CM	CS	CM	CS	CM	CS	CS	CM	CM	CS	CM	CM	CM	CS	CM	CM	CM	
44499-0105	16	16BC	CM	CS	CS	CS	CS	CS	CS	CS	CS	CS	CS	CS	CS	CM	CS	-	-	-	-	-	-	-	-	
44499-0106	08	08BC	CS	CS	CM	CS	CS	CS	CM	CS	-	-	-	-	-	-	-	-	-	-	-	-	-	-	-	
44499-0107	24	24AD	DM	DM	DM	DM	DM	DM	DM	DM	DM	DM	DM	DM	DM	DM	DM	DM	DM	DM	DM	DM	DM	DM	DM	
44499-0108	14	14BC	CS	CS	CS	CS	CS	CS	CM	CS	CS	CS	CS	CS	CS	-	-	-	-	-	-	-	-	-	-	
44499-0109	24	24BC	CM	CS	CS	CM	CS	CS	CS	CS	CS	CS	CS	CS	CM	CS	CS	CM	CS	CS	CS	CS	CS	CS	CS	
44499-0111	06	06BC	CM	CS	CS	CM	CS	CS	-	-	-	-	-	-	-	-	-	-	-	-	-	-	-	-	-	
44499-0112	24	24BC	CS	CM	CM	CS	CS	CS	CS	CS	CS	CS	CS	CS	CM	CM	CS	CS	CS	CS	CS	CS	CS	CS	CS	

CHARACTERISTICS LEGEND:

CIRCUIT SIZE _____

(02-24)

HOUSING MATERIAL _____

A = NYLON 6/6, U.L. 94V-2,
COLOR: NATURAL

B = NYLON 6/6, U.L. 94V-0,
COLOR: NATURAL

TERMINAL PLATING _____

C = SELECT GOLD

D = MATTE TIN OVERALL

* = MIXED TIN AND GOLD

TERMINAL PLATING AND LENGTH CODE

- CS = SELECT GOLD, STANDARD LENGTH
- DS = MATTE TIN, STANDARD LENGTH
- CM = SELECT GOLD, MATE-FIRST/BREAK-LAST (LONGER)
- DM = MATTE TIN, MATE-FIRST/BREAK-LAST (LONGER)
- V = VOID CIRCUIT

THIS DRAWING CONTAINS INFORMATION THAT IS PROPRIETARY TO MOLEX ELECTRONIC TECHNOLOGIES, LLC AND SHOULD NOT BE USED WITHOUT WRITTEN PERMISSION																										
SYMBOLS			DIMENSION UNITS			SCALE			CURRENT REV DESC: ADDED PT. #444990132																	
= 0 = 0 = 0			INCH/MM			2:1			EC NO: 623458 DRWN: DSTEIER 2019/08/29 CHK'D: JCOMERCI 2019/09/06 APPR: JCOMERCI 2019/09/06																	
= 0 = 0 = 0			GENERAL TOLERANCES (UNLESS SPECIFIED)																							
= 0 = 0 = 0			<table border="1"> <tr><th>PLACES</th><th>MM</th><th>INCH</th></tr> <tr><td>4 PLACES</td><td>±</td><td>±</td></tr> <tr><td>3 PLACES</td><td>±</td><td>± 0.01</td></tr> <tr><td>2 PLACES</td><td>± 0.25</td><td>± 0.015</td></tr> <tr><td>1 PLACE</td><td>± 0.38</td><td>±</td></tr> </table>			PLACES	MM	INCH	4 PLACES	±	±	3 PLACES	±	± 0.01	2 PLACES	± 0.25	± 0.015	1 PLACE	± 0.38	±	INITIAL REVISION:					
PLACES	MM	INCH																								
4 PLACES	±	±																								
3 PLACES	±	± 0.01																								
2 PLACES	± 0.25	± 0.015																								
1 PLACE	± 0.38	±																								
= 0 = 0			<table border="1"> <tr><th>PLACES</th><th>MM</th><th>INCH</th></tr> <tr><td>0 PLACES</td><td>±</td><td>±</td></tr> </table>			PLACES	MM	INCH	0 PLACES	±	±	DRWN: DSTEIER 2019/08/29 APPR: JCOMERCI 2019/09/06														
PLACES	MM	INCH																								
0 PLACES	±	±																								
= 0 = 0			DRAFT WHERE APPLICABLE MUST REMAIN WITHIN DIMENSIONS			THIRD ANGLE PROJECTION			DRAWING			SERIES														
= 0 = 0									C-SIZE			44499														
DOCUMENT STATUS P1 RELEASE DATE 2019/09/06 13:29:40			DOCUMENT NUMBER 444990000-SD DOC TYPE PSD DOC PART 000 REVISION A						PRODUCT CUSTOMER DRAWING MATERIAL NUMBER SEE CHART CUSTOMER SHEET NUMBER 2 OF 3																	

ITEM NO.	CKT. SIZE	CHARACTERISTIC DESCRIPTION	LETTER INDICATES PIN PLATING AND LENGTH REQUIRED AT EACH CIRCUIT LOCATION. SEE NOTE 2 ON SHEET 1.																							
			1	2	3	4	5	6	7	8	9	10	11	12	13	14	15	16	17	18	19	20	21	22	23	24
44499-0113	24	24BD	DS	V	DS	V	DS	V	DS	V	V	DS	DS	DS	DS	V	DS	V	DS	V	DS	V	DS	DS	DS	
44499-0114	14	14BD	DS	V	DS	V	DS	V	DS	DS	V	DS	V	DS	V	DS	-	-	-	-	-	-	-	-	-	
44499-0115	18	18BD	DS	V	V	DS	V	V	DS	DS	DS	DS	V	V	DS	V	V	DS	DS	DS	-	-	-	-	-	
44499-0116	04	04BD	DS	DS	DM	DM	-	-	-	-	-	-	-	-	-	-	-	-	-	-	-	-	-	-		
44499-0117	10	10BD	DM	DM	DM	DM	DM	DM	DM	DM	DM	DM	DM	DM	DM	DM	DM	DM	DM	DM	DM	DM	DM	DM	DM	
44499-0118	14	14BD	DM	DM	DM	DM	DM	DM	DM	DM	DM	DM	DM	DM	DM	DM	DM	DM	DM	DM	DM	DM	DM	DM	DM	
44499-0119	14	14BC	CM	CM	CM	CM	CS	CM	CS	CM	CM	CM	CM	CM	CM	CS	-	-	-	-	-	-	-	-	-	
44499-0120	14	14BC	CM	CM	CM	CM	CS	CM	CM	CM	CM	CM	CM	CS	CM	CM	-	-	-	-	-	-	-	-	-	
44499-0121	10	10BC	CM	CS	CS	CS	CS	CM	CS	CS	CS	CS	-	-	-	-	-	-	-	-	-	-	-	-	-	
44499-0122	18	18BC	CM	CM	CM	CM	CM	CM	CM	CM	CM	CM	CM	CS	CS	CM	CM	CM	CM	CM	-	-	-	-	-	
44499-0123	10	10BD	DS	V	DS	V	DS	DS	V	DS	V	DS	-	-	-	-	-	-	-	-	-	-	-	-	-	
44499-0124	14	14BC	CM	CM	CM	CM	CM	CM	CM	CM	CS	CM	CM	CS	CM	CM	-	-	-	-	-	-	-	-	-	
44499-0125	14	14BC	CM	CM	CM	CM	CS	CM	CM	CM	CS	CM	CM	CM	CM	CM	-	-	-	-	-	-	-	-	-	
44499-0126	14	14BC	CM	CM	CM	CM	CS	CM	CM	CM	CM	CM	CS	CS	CM	CM	-	-	-	-	-	-	-	-	-	
44499-0127	18	18BD	DM	DM	DM	DM	DM	DS	DS	DM	DS	DM	DM	DM	DM	DM	DM	DM	DM	DM	-	-	-	-	-	
44499-0128	14	14BC	CM	CM	CM	CS	CS	CM	CS	CM	CM	CM	CS	CM	CM	CS	-	-	-	-	-	-	-	-	-	
44499-0129	14	14BD	DM	DM	DM	DS	DS	DM	DS	DM	DM	DM	DS	DS	DM	DS	-	-	-	-	-	-	-	-	-	
44499-0130	14	14BD	DM	DS	DS	DS	DS	DS	DM	DM	DS	DM	DS	DS	DM	DM	-	-	-	-	-	-	-	-	-	
44499-0131	14	14BC	CS	CS	CS	CS	CM	CS	CS	CS	CM	CS	CS	CM	CS	CS										
44499-0132	18	18BD	DS	DS	DS	DM	DM	DM	DM	DM	DS	DS	DS	DS	DS	DS	DS	DS	DS	DS						

CHARACTERISTICS LEGEND:

CIRCUIT SIZE _____ ** * *

(02-24)

HOUSING MATERIAL _____

A = NYLON 6/6, U.L. 94V-2,
COLOR: NATURAL

B = NYLON 6/6, U.L. 94V-0,
COLOR: NATURAL

TERMINAL PLATING _____

C = SELECT GOLD

D = MATTE TIN OVERALL

* = MIXED TIN AND GOLD

TERMINAL PLATING AND LENGTH CODE

CS = SELECT GOLD, STANDARD LENGTH

DS = MATTE TIN, STANDARD LENGTH

CM = SELECT GOLD, MATE-FIRST/BREAK-LAST (LONGER)

DM = MATTE TIN, MATE-FIRST/BREAK-LAST (LONGER)

V = VOID CIRCUIT

SYMBOLS	THIS DRAWING CONTAINS INFORMATION THAT IS PROPRIETARY TO MOLEX ELECTRONIC TECHNOLOGIES, LLC AND SHOULD NOT BE USED WITHOUT WRITTEN PERMISSION			
	DIMENSION UNITS	SCALE	CURRENT REV DESC: ADDED PT. #444990132	
∇ = 0	INCH/MM	2:1		
∇ = 0	GENERAL TOLERANCES (UNLESS SPECIFIED)			
∇ = 0		MM	INCH	EC NO: 623458
∇ = 0	4 PLACES	±	±	DRWN: DSTEIER 2019/08/29
∇ = 0	3 PLACES	±	± 0.01	CHK'D: JCOMERCI 2019/09/06
∇ = 0	2 PLACES	± 0.25	± 0.015	APPR: JCOMERCI 2019/09/06
∇ = 0	1 PLACE	± 0.38	±	INITIAL REVISION:
∇ = 0	0 PLACES	±	±	DRWN: DSTEIER 2019/08/29
∇ = 0	ANGULAR TOL	± 0.5 °		APPR: JCOMERCI 2019/09/06
∇ = 0	DRAFT WHERE APPLICABLE MUST REMAIN WITHIN DIMENSIONS	THIRD ANGLE PROJECTION	DRAWING	SERIES
			C-SIZE	44499

molex			
SELECTIVELY-LOADED RT ANGLE DUAL ROW HEADER (MATE-FIRST/BREAK-LAST)			
PRODUCT CUSTOMER DRAWING			
DOCUMENT NUMBER	DOC TYPE	DOC PART	REVISION
444990000-SD	PSD	000	A
MATERIAL NUMBER	CUSTOMER	SHEET NUMBER	
SEE CHART		3 OF 3	

X-ON Electronics

Largest Supplier of Electrical and Electronic Components

Click to view similar products for [Headers & Wire Housings](#) category:

Click to view products by [Molex](#) manufacturer:

Other Similar products are found below :

[892-18-020-10-001101](#) [58102-G61-06LF](#) [582553-1](#) [0009485154](#) [009176003701906](#) [0050291907](#) [LY20-4P-DT1-P1E-BR](#) [02.125.8002.8](#)
[609-3404](#) [61062-3](#) [622-0430](#) [622-3653LF](#) [63453-116](#) [636-1030](#) [636-1427](#) [636-3427](#) [636-4007](#) [641938-9](#) [641991-4](#) [644827-2](#) [65817-010LF](#)
[65817-015LF](#) [65863-015LF](#) [66207-023LF](#) [67095-007LF](#) [67601157](#) [68648-049](#) [70.362.1628.0](#) [70-4210](#) [70-4226B](#) [70-4853B](#) [707-5020](#) [707-5028](#) [71.350.2428.0](#) [71918-208LF](#) [71961-016LF](#) [733-134](#) [733-162](#) [754199-000](#) [760-3052](#) [787-8014-00](#) [79531-3000](#) [FCN-360C032-B](#) [FCN-367T-T012/H](#) [FCN-723D010/2](#) [80.063.4001.1](#) [800-90-001-10-001000](#) [800-90-010-10-002000](#) [801-43-002-10-013000](#) [801-43-006-10-002000](#)