

NOTES:

- MATERIAL:
METAL SHELL: BRASS
HOUSING: POLYAMIDE, UL94 V-0, COLOR BLACK
INSERT: POLYAMIDE, UL94 V-0, COLOR BLACK
TERMINAL: PHOSPHOR BRONZE
- PLATING:
TERMINAL:
CONTACT AREA: GOLD(Au), THICKNESS=50 MICROINCH/1.27 MICROMETER
SOLDER TAIL: TIN(Sn), THICKNESS=100 MICROINCH MINIMUM
UNDER PLATE: NICKEL (Ni), THICKNESS=50 MICROINCH/1.27 MICROMETER
METAL SHELL:
SOLDER AREA: TIN(Sn), THICKNESS=100 MICROINCH MINIMUM
UNDER PLATE: NICKEL (Ni), (SOLDERING AVAILABLE)
SURFACE APPEARANCE: BRIGHT.
- RECOMMENDED PCB THICKNESS: 1.60±0.05
- PRODUCT SPECIFICATION REFER TO PS-48025-002
- TEST SUMMARY REFER TO TS-48025-005
- PACKAGING SPECIFICATION REFER TO PK-48025-001
- LEAD FREE AND ROHS COMPLIANCE PRODUCT.

THIS DRAWING CONTAINS INFORMATION THAT IS PROPRIETARY TO MOLEX ELECTRONIC TECHNOLOGIES, LLC AND SHOULD NOT BE USED WITHOUT WRITTEN PERMISSION									
SYMBOLS		DIMENSION UNITS		SCALE		CURRENT REV DESC:			
∇ = 0		mm		1:1		EC NO: 637574 DRWN: CCHEN103 2019/08/30 CHK'D: SHLENI 2020/05/28 APPR: SHLENI 2020/05/28 INITIAL REVISION: DRWN: ALLIN 2005/08/01 APPR: WWSCHANG 2005/08/02			
E = 0		GENERAL TOLERANCES (UNLESS SPECIFIED)							
F = 0		ANGULAR TOL ± 3.0°							
S = 0		4 PLACES	±						
▼ = 0		3 PLACES	±						
∇ = 0		2 PLACES	±	0.25					
⊠ = 0		1 PLACE	±	0.25					
■ = 0		0 PLACES	±						
∇ = 0		DRAFT WHERE APPLICABLE MUST REMAIN WITHIN DIMENSIONS		THIRD ANGLE PROJECTION		DRAWING		SERIES	
				A4-SIZE		48025		MATERIAL NUMBER	
								CUSTOMER	
								SHEET NUMBER	

molex

MODULAR JACK WITH
INTEGRATED MAGNETICS LED (LEAD FREE
VERSION)

PRODUCT CUSTOMER DRAWING

DOCUMENT NUMBER	DOC TYPE	DOC PART	REVISION
SD-48025-005	PSD	001	C1

DOCUMENT STATUS	P1	RELEASE DATE	2020/05/28	00:36:56
-----------------	----	--------------	------------	----------

MAGNETIC ELECTRICAL SPECIFICATIONS:

- 1.0 TURNS RATIO:(P4-P5-P6):(J3-J6):1CT:1CT
(P3-P2-P1):(J1-J2):1CT:1CT
- 2.0 INDUCTANCE:(P4-P6):350uH MIN. @0.1V,100KHz,8mA DC Bias.
(P3-P1):350uH MIN. @0.1V,100KHz,8mA DC Bias.
- 3.0 LEAKAGE INDUCTANCE:P6-P5-P4(WITH J6 AND J3 SHORT):0.3 MAX.@1MHz.
P3-P2-P1(WITH J2 AND J1 SHORT):0.3 MAX.@1MHz.
- 4.0 INTERWINDING CAPACITANCE:(P6,P5,P4) TO (J6,J3):30pf MAX @1MHz.
(P3,P2,P1) TO (J2,J1):30pf MAX @1MHz.
- 5.0 DC RESISTANCE:(J6-J3)=(J2-J1):1.3 ohms Max.
- 6.0 RETURN LOSS:(P4-P6)(P1-P3)
1MHz TO 30MHz:18dB min.
30MHz TO 80MHz:12dB min.
- NOTE:100 OHMS CONNECTED TO (J2-J1) OR (J3-J6).
- 7.0 HI-POT:(J1,J2) TO (P1,P3):1500 VAC OR 2250 VDC.
(J3,J6) TO (P4,P6):1500 VAC OR 2250 VDC.
- 8.0 INSERTION LOSS:1.1 dB MAX.
100KHz TO 100MHz.
- 9.0 CROSS TALK:1-100 MHz:30 dB MIN.
- 10.0 COMMON TO COMMON MODE REJECTION:1MHz TO 100MHz:35 dB MIN.

LED ELECTRICAL SPECIFICATION

PARAMETER	YELLOW (TYP.)		GREEN (TYP.)		UNITS	TEST CONDITIONS
POWER DISSIPATION	105		105		mW	
REVERSE VOLTAGE	5		5		V	
PEAK WAVELENGTH	585		565		nm	IF=20mA
FORWARD VOLTAGE	2.1	MAX.=2.5	2.2	MAX.=2.5	V	IF=20mA

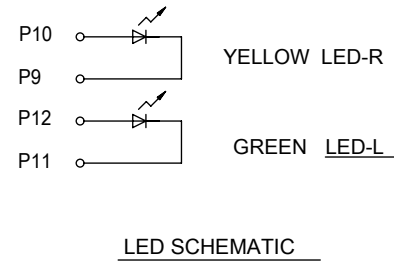
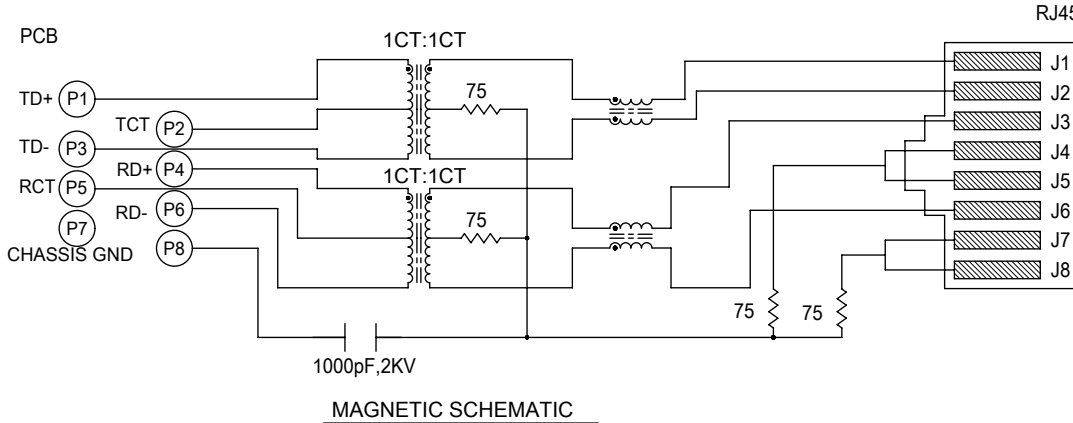

SYMBOLS = 0 = 0 = 0 = 0 = 0 = 0 = 0	THIS DRAWING CONTAINS INFORMATION THAT IS PROPRIETARY TO MOLEX ELECTRONIC TECHNOLOGIES, LLC AND SHOULD NOT BE USED WITHOUT WRITTEN PERMISSION		CURRENT REV DESC: EC NO: 637574 DRWN: CCHEN103 2019/08/30 CHK'D: SHLENI 2020/05/28 APPR: SHLENI 2020/05/28		 MODULAR JACK WITH INTEGRATED MAGNETICS LED (LEAD FREE VERSION)		
	DIMENSION UNITS: mm SCALE: 1:1	GENERAL TOLERANCES (UNLESS SPECIFIED) ANGULAR TOL ± 3.0°		PRODUCT CUSTOMER DRAWING			
	4 PLACES ± 3 PLACES ± 2 PLACES ± 0.25 1 PLACE ± 0.25 0 PLACES ±	INITIAL REVISION: DRWN: ALLIN 2005/08/01 APPR: WWSCHANG 2005/08/02		DOCUMENT NUMBER SD-48025-005	DOC TYPE PSD	DOC PART 001	REVISION C1
	DRAFT WHERE APPLICABLE MUST REMAIN WITHIN DIMENSIONS	THIRD ANGLE PROJECTION	DRAWING A4-SIZE	SERIES 48025	MATERIAL NUMBER 48025-4000	CUSTOMER GENERAL MARKET	SHEET NUMBER 2 OF 2

DOCUMENT STATUS	P1	RELEASE DATE	2020/05/28	00:36:56
-----------------	----	--------------	------------	----------

X-ON Electronics

Largest Supplier of Electrical and Electronic Components

Click to view similar products for [Modular Connectors / Ethernet Connectors](#) category:

Click to view products by [Molex](#) manufacturer:

Other Similar products are found below :

[8949-H88/06BLKA/SN](#) [74441-0010/BKN](#) [MP1010RX-1000](#) [MP44RX-1000](#) [PHP-6P6C-5](#) [GAX-3-66](#) [GAX-8-62](#) [GDCX-PA-66-50](#) [GDCX-PN-64](#) [GDCX-PN-66](#) [GDCX-PN-66-50](#) [GDLX-A-66](#) [GDLX-N-66](#) [GDLX-S-66](#) [GDLX-S-88K](#) [GDTX-S-88-50](#) [GDX-PA-1010](#) [GLX-N-1010M-BLK](#) [GLX-S-88M-BLK](#) [GMX-N-1010](#) [GMX-S-1010](#) [GMX-S-66](#) [GMX-SMT4-N-88](#) [GPX-2-64](#) [GSGX-N-2-88](#) [GSGX-N-4-88](#) [GSX-NS2-88-3.05](#) [GSX-NS2-88-3.05-50](#) [GSX-NS-88-3.05-50](#) [PT-108A-8C-UL](#) [PT-J951-8C](#) [PTS-J531-8CS-50UL](#) [1-1775629-2](#) [A-2014-0-4](#) [GWLX-S-88-GR](#) [GWLX-S9-88-YG](#) [DC-1021-8-WH-6](#) [1300530003](#) [1324640-4](#) [RJ11FTVC2G](#) [RJ11FTVC2N](#) [RJFTVX2SA1G](#) [132764-001](#) [1413235](#) [MP88X-1000](#) [MPS88RX-5000](#) [MRJR-5481-0F2](#) [E5288-S000K3-L](#) [E5908-15A242-L](#) [155302-001](#)