

NOTES

1. 梱包数量：1000個/リール
NUMBER OF CONNECTORS : 1000PCS/REEL
2. リードテープ長さ LEAD TAPE LENGTH

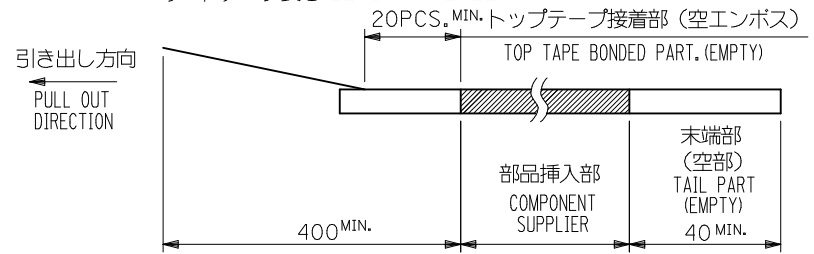

3. トップテープの剥離強度：0.1~1.3N (10gf~130gf) (剥離方向は下図参照)
尚、本規格値は出荷時に適用。(但し、輸送時に剥離が発生しないこと。)
PEELING OFF FORCE OF TOP TAPE : 0.1~1.3N (10gf~130gf)
(PEELING DIRECTION AS SHOWN IN FOLLOWING FIG.)
THIS REQUIREMENT SHOULD BE APPLIED AT SHIPMENT.
PEEL OFF SHOULD NOT BE ALLOWED , DURING TRANSPORTATION.

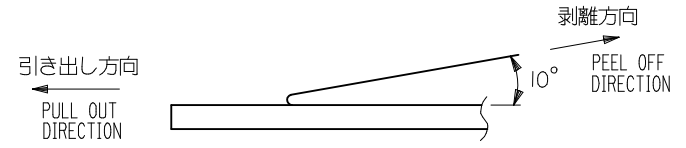

4. 52610-**-16のアクチュエータはハウジング内に押し下げた状態とする。
詳細寸法については 製品単体図面を参照下さい。
ACTUATOR OF PART NO. 52610-**-16 SHULD BE LOCKED.
RE DETAILED DIMENSIONS , SEE SALES DRAWING FOR CONNECTOR.
5. 材料(MATERIAL)
キャリアテープ(CARRIER TAPE) : ポリプロピレン(POLYPROPYLENE)
トップテープ(TOP TAPE) : PET , PE , PEF
リール(REEL) : ポリスチレン (PS) <リサイクル材を含む>
POLYSTYREN(PS) <RECYCLE MATERIAL CONTAINED>
6. 本製品は 52610-**-90 の鉛フリー品です
7. 本製品は乾燥剤入り、ハイバリア梱包仕様である。
THIS PRODUCT IS HIGH BARRIER PACKAGE WITH DESICCANT.

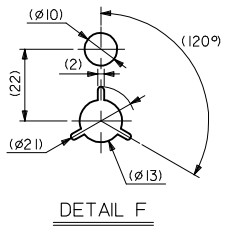
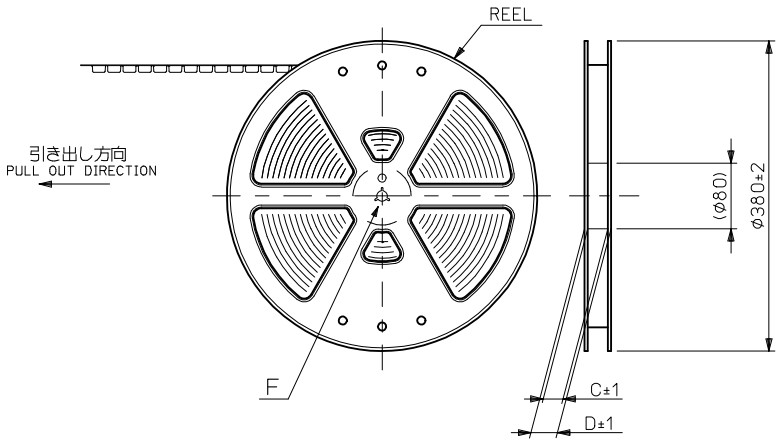

REVISED EC NO: J2009-2061 DRWN:TKON 2009/05/20 CHKD:HMATSUMOTO 2009/05/21 APPR:NUKITA 2009/05/21	DESCRIPTION REV	GENERAL TOLERANCES (UNLESS SPECIFIED)		DIMENSION STYLE MM ONLY		SCALE ---	DESIGN UNITS METRIC	52610-**-71	MODEL NO.
		10 UNDER	±0.2	DRAWN BY T. UENO	DATE '03/12/12	TITLE 1.0 FPC CONN SMT ZIF EMBSTP PKG -LEAD FREE-			
		10 OVER 30 UNDER	±0.25	CHECKED BY M. SASAO	DATE '03/12/12	MOLEX INCORPORATED			
		30 OVER	±0.3	APPROVED BY M. SASAO	DATE '03/12/12	DOCUMENT NO. SD-52610-038			
ANGULAR ±3 °		DRAFT WHERE APPLICABLE MUST REMAIN WITHIN DIMENSIONS		MATERIAL NO. SEE TABLE		SHEET NO. 1 OF 5			
THIS DRAWING CONTAINS INFORMATION THAT IS PROPRIETARY TO MOLEX INCORPORATED AND SHOULD NOT BE USED WITHOUT WRITTEN PERMISSION									

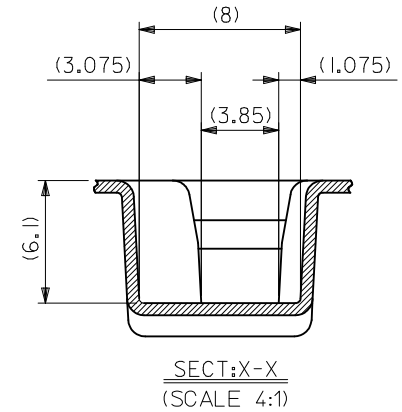
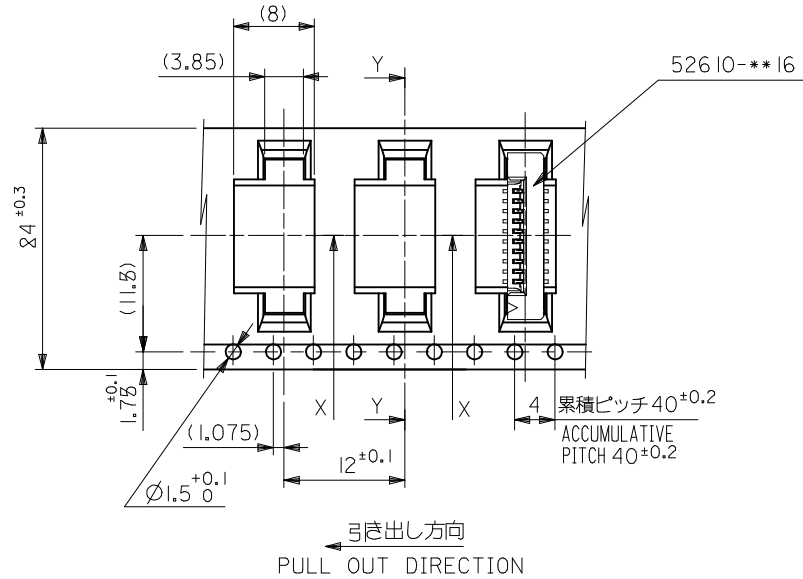
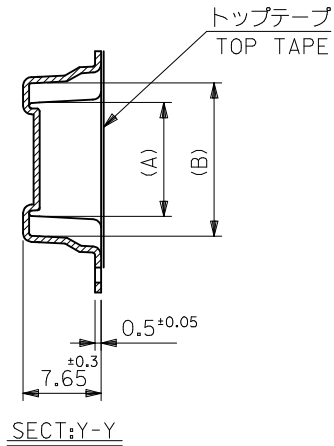

24	29.4	25.4	15.25	11.32	52610-1071	10
			14.25	10.32	52610-0971	9
			13.25	9.32	52610-0871	8
			12.25	8.32	52610-0771	7
			11.25	7.32	52610-0671	6
			10.25	6.32	52610-0571	5
キャリアテープ幅 CARRIER TAPE WIDTH	D	C	(B)	(A)	MATERIAL NO.	極数 CKT.
			52610-**-71		MODEL NO.	

REVISED EC NO: J2009-2061 DRW:ITKON 2009/05/20 CHKD:HMATSUMOTO 2009/05/21 APPR:NUKITA 2009/05/21	GENERAL TOLERANCES (UNLESS SPECIFIED)		DIMENSION STYLE MM ONLY	SCALE ---	DESIGN UNITS METRIC	THIRD ANGLE PROJECTION
	10 UNDER	± 0.2	DRAWN BY T.UENO	DATE '03/12/12	TITLE 1.0 FPC CONN SMT ZIF EMBSTP PKG -LEAD FREE- MOLEX INCORPORATED	
	10 OVER 30 UNDER	± 0.25	CHECKED BY M.SASAO	DATE '03/12/12		
	30 OVER	± 0.3	APPROVED BY M.SASAO	DATE '03/12/12		
ANGULAR	± 3 °	MATERIAL NO.	DOCUMENT NO.			
	DRAFT WHERE APPLICABLE MUST REMAIN WITHIN DIMENSIONS		SEE TABLE	SD-52610-038		SHEET NO. 2 OF 5
	THIS DRAWING CONTAINS INFORMATION THAT IS PROPRIETARY TO MOLEX INCORPORATED AND SHOULD NOT BE USED WITHOUT WRITTEN PERMISSION					

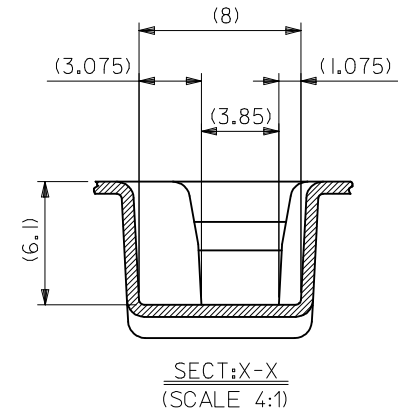
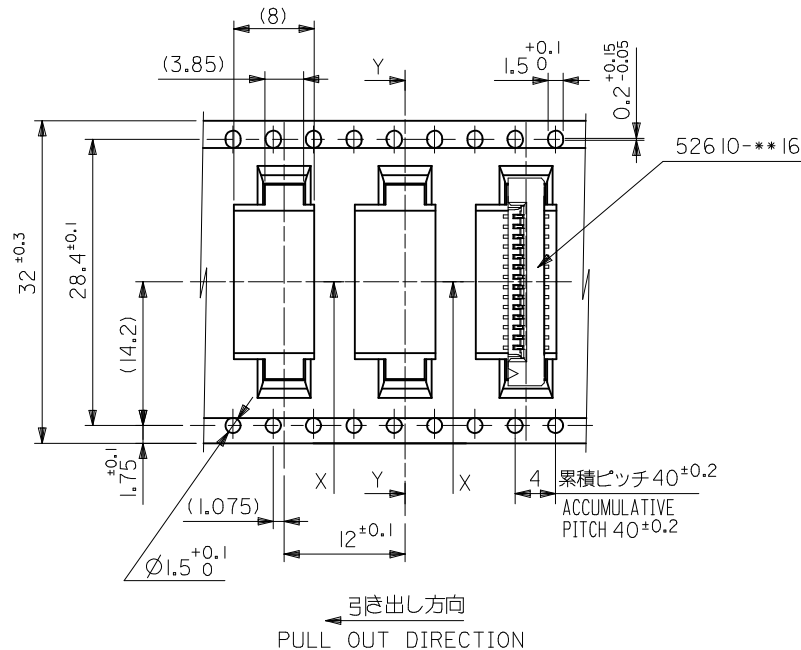
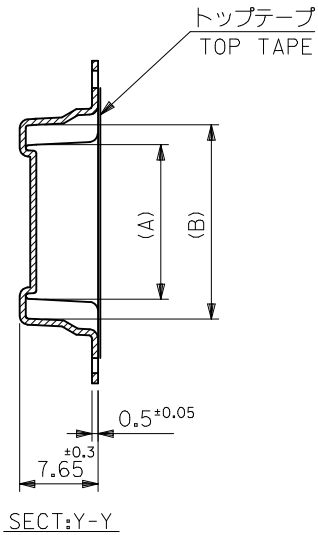

32	37.4	33.4	20.25	16.32	52610-1571	15
			19.25	15.32	52610-1471	14
			18.25	14.32	52610-1371	13
			17.25	13.32	52610-1271	12
			16.25	12.32	52610-1171	11
キャリアテープ幅 CARRIER TAPE WIDTH	D	C	(B)	(A)	MATERIAL NO.	種数 CKT.

REVISED EC NO: J2009-2061 DRWN:TKON 2009/05/20 CHKD:HMATSUMOTO 2009/05/21 APPR:NUKITA 2009/05/21	GENERAL TOLERANCES (UNLESS SPECIFIED)		DIMENSION STYLE MM ONLY		SCALE ---	DESIGN UNITS METRIC	THIRD ANGLE PROJECTION	
	10 UNDER	±0.2	DRAWN BY T.UENO	DATE '03/12/12	TITLE 1.0 FPC CONN SMT ZIF EMBSTP PKG -LEAD FREE-			
	10 OVER 30 UNDER	±0.25	CHECKED BY M.SASAO	DATE '03/12/12	MOLEX INCORPORATED			
	30 OVER	±0.3	APPROVED BY M.SASAO	DATE '03/12/12	DOCUMENT NO. SD-52610-038		SHEET NO. 3 OF 5	
	ANGULAR ±3 ° DRAFT WHERE APPLICABLE MUST REMAIN WITHIN DIMENSIONS		MATERIAL NO. SEE TABLE		THIS DRAWING CONTAINS INFORMATION THAT IS PROPRIETARY TO MOLEX INCORPORATED AND SHOULD NOT BE USED WITHOUT WRITTEN PERMISSION			

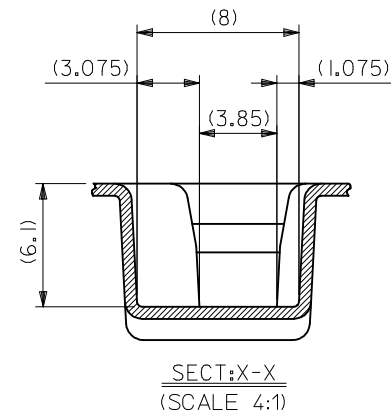
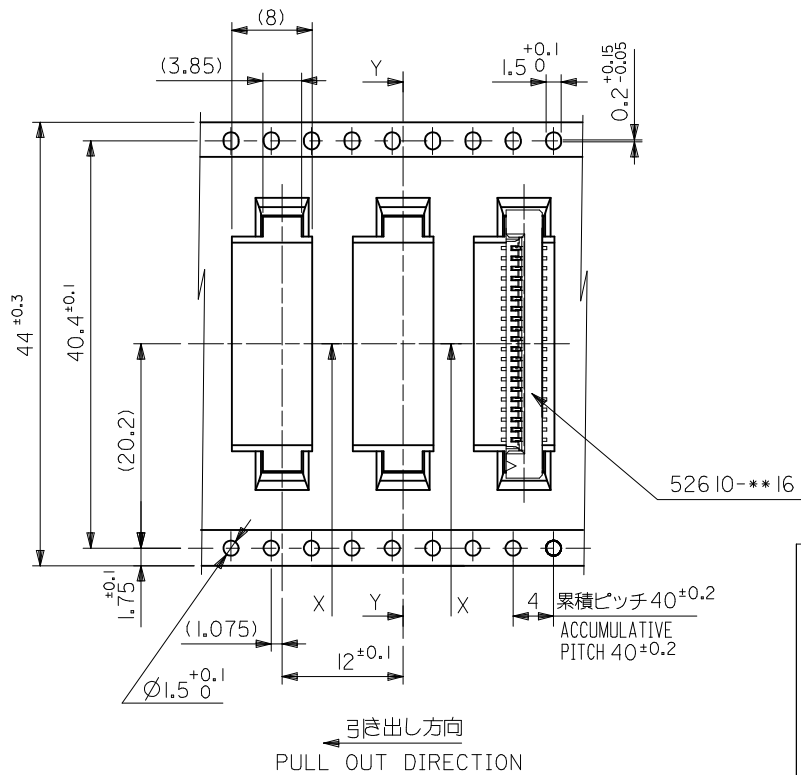
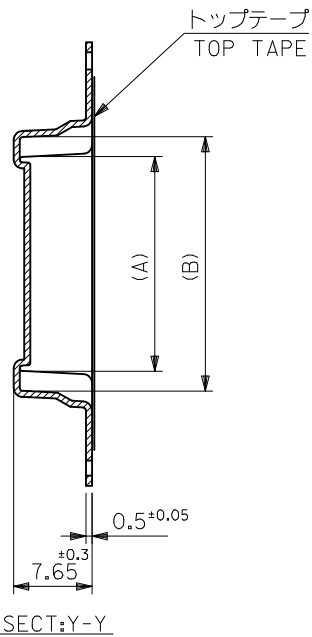

44	49.4	45.4	31.25	27.32	52610-2671	26
			30.25	26.32	52610-2571	25
			29.25	25.32	52610-2471	24
			28.25	24.32	52610-2371	23
			27.25	23.32	52610-2271	22
			26.25	22.32	52610-2171	21
			25.25	21.32	52610-2071	20
			24.25	20.32	52610-1971	19
			23.25	19.32	52610-1871	18
			22.25	18.32	52610-1771	17
21.25	17.32	52610-1671	16			
キャリアテープ幅 CARRIER TAPE WIDTH	D	C	(B)	(A)	MATERIAL NO.	極数 CKT.
			52610-**-71	MODEL NO.		

REVISED EC NO: J2009-2061 DRWN:TKON 2009/05/20 CHKD:HMATSUMOTO 2009/05/21 APPR:NUKITA 2009/05/21	GENERAL TOLERANCES (UNLESS SPECIFIED)		DIMENSION STYLE MM ONLY		SCALE ---	DESIGN UNITS METRIC		THIRD ANGLE PROJECTION	
	10 UNDER	±0.2	DRAWN BY T. UENO	DATE '03/12/12	TITLE 1.0 FPC CONN SMT ZIF EMBSTP PKG -LEAD FREE-				
	10 OVER 30 UNDER	±0.25	CHECKED BY M. SASAO	DATE '03/12/12	MOLEX INCORPORATED				
	30 OVER	±0.3	APPROVED BY M. SASAO	DATE '03/12/12	DOCUMENT NO. SD-52610-038				
	ANGULAR ±3 °		MATERIAL NO. SEE TABLE		SHEET NO. 4 OF 5				
DRAFT WHERE APPLICABLE MUST REMAIN WITHIN DIMENSIONS		THIS DRAWING CONTAINS INFORMATION THAT IS PROPRIETARY TO MOLEX INCORPORATED AND SHOULD NOT BE USED WITHOUT WRITTEN PERMISSION							

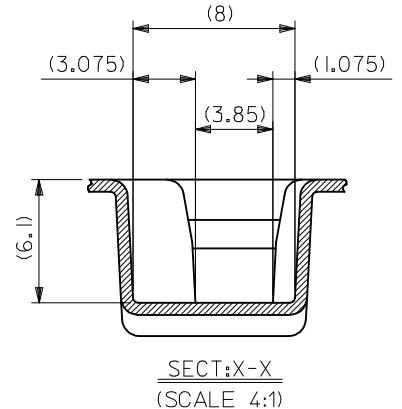
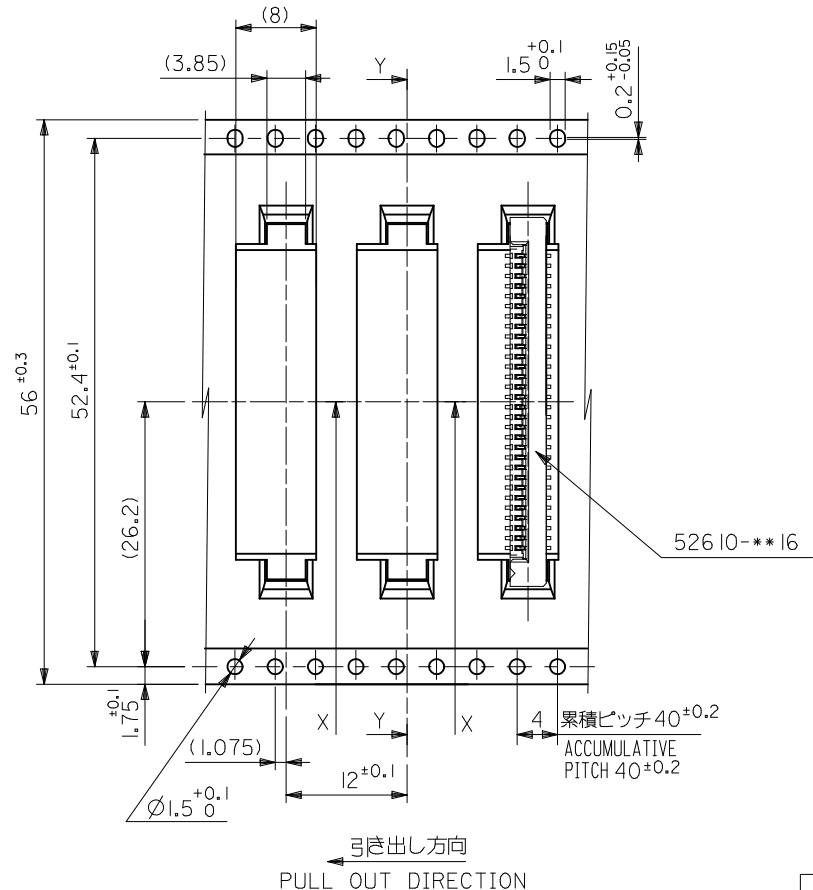
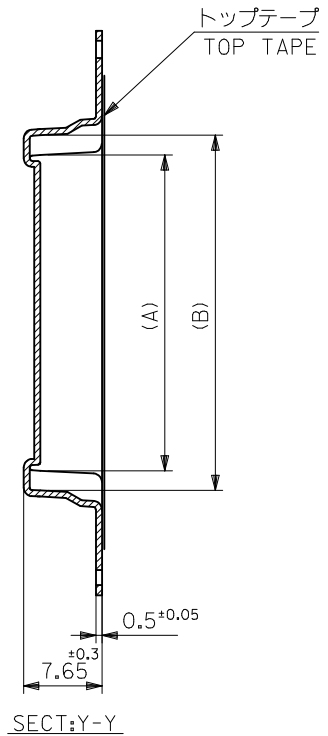

56	61.4	57.4	35.25	31.32	52610-3071	30
			33.25	29.32	52610-2871	28
キャリアテープ幅 CARRIER TAPE WIDTH	D	C	(B)	(A)	MATERIAL NO.	種数 CKT.
					52610-**-71	MODEL NO.

REVISED EC NO: J2009-2061 DRWN:TKON 2009/05/20 CHKD:HMATSUMOTO 2009/05/21 APPR:NIKIITA 2009/05/21	GENERAL TOLERANCES (UNLESS SPECIFIED)		DIMENSION STYLE MM ONLY		SCALE ---	DESIGN UNITS METRIC	THIRD ANGLE PROJECTION
	10 UNDER	±0.2	DRAWN BY T.UENO	DATE '03/12/12	TITLE 1.0 FPC CONN SMT ZIF EMBSTP PKG -LEAD FREE-		
	10 OVER 30 UNDER	±0.25	CHECKED BY M.SASAO	DATE '03/12/12	MOLEX INCORPORATED		
	30 OVER	±0.3	APPROVED BY M.SASAO	DATE '03/12/12	DOCUMENT NO. SD-52610-038		
	ANGULAR ±3 °	DRAFT WHERE APPLICABLE MUST REMAIN WITHIN DIMENSIONS		MATERIAL NO. SEE TABLE		SHEET NO. 5 OF 5	
		THIS DRAWING CONTAINS INFORMATION THAT IS PROPRIETARY TO MOLEX INCORPORATED AND SHOULD NOT BE USED WITHOUT WRITTEN PERMISSION					

X-ON Electronics

Largest Supplier of Electrical and Electronic Components

Click to view similar products for [FFC & FPC Connectors](#) category:

Click to view products by [Molex](#) manufacturer:

Other Similar products are found below :

[HFW11R-1STE1H1LF](#) [FH29B-100S-0.2SHW\(99\)](#) [FA5S008HP1](#) [FH29B-120S-0.2SHW\(99\)](#) [FH29B-80S-0.2SHW\(99\)](#) [FHS-16](#) [FPH-2022G](#)
[52610-1075](#) [52610-1275](#) [52610-1934](#) [XF3M\(1\)-1415-1B-R100](#) [501864-3091-TR225](#) [0525594033](#) [086210010340800](#) [086222026001800](#)
[52271-2869-CUT-TAPE](#) [62674-201121DLF](#) [62684-36210E9ALF](#) [52610-1675](#) [52746-1671-TR250](#) [10051922-2810EHLF](#) [6-520415-9](#)
[BD021-09A-A1-0350-0200-0550-LD](#) [SFV6R-1STE9HLF](#) [XF3M-2915-1B-R100](#) [1658549-1](#) [62674-221121ALF](#) [46214008010800](#)
[046298003000883](#) [151660622](#) [842-816-2630-035](#) [AYF530665TA](#) [AYF351525](#) [046296011930846+](#) [AYF352325A](#) [046254020000800+](#)
[FH19C-13S-0.5SH\(99\)](#) [FH39J-51S-0.3SHW\(99\)](#) [AYF355125A](#) [AYF530365TA](#) [FH29B-44S-0.2SHW\(99\)](#) [SFW5R-2STAE9LF](#) [AYF351125A](#)
[AYF350725A](#) [62684-502100AHLF](#) [FH39-61S-0.3SHW\(99\)](#) [AYF414035A](#) [10064555-172520HLF](#) [AYF212335A](#) [504754-2500](#)