

F

E

D

C

B

A

F

E

D

C

B

A

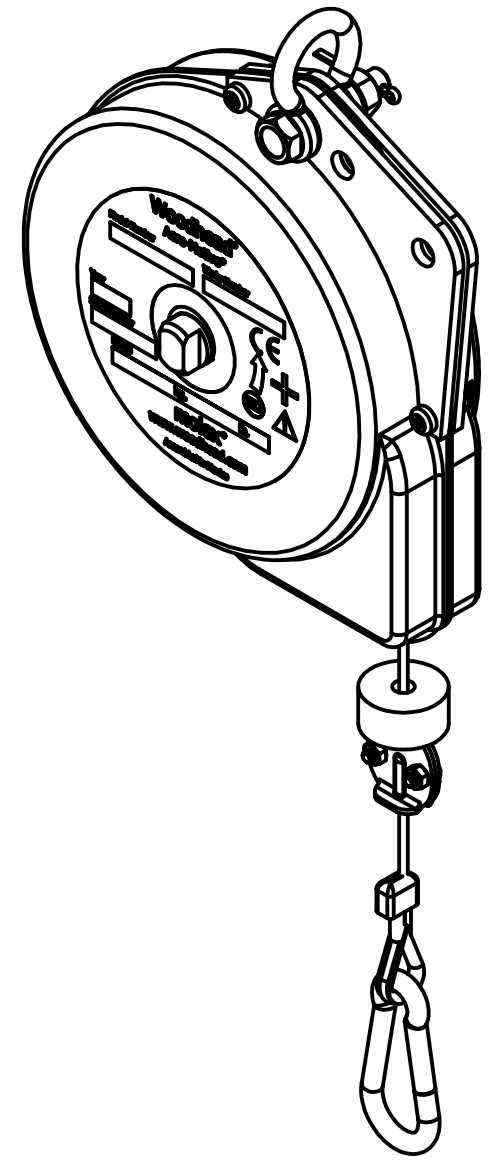
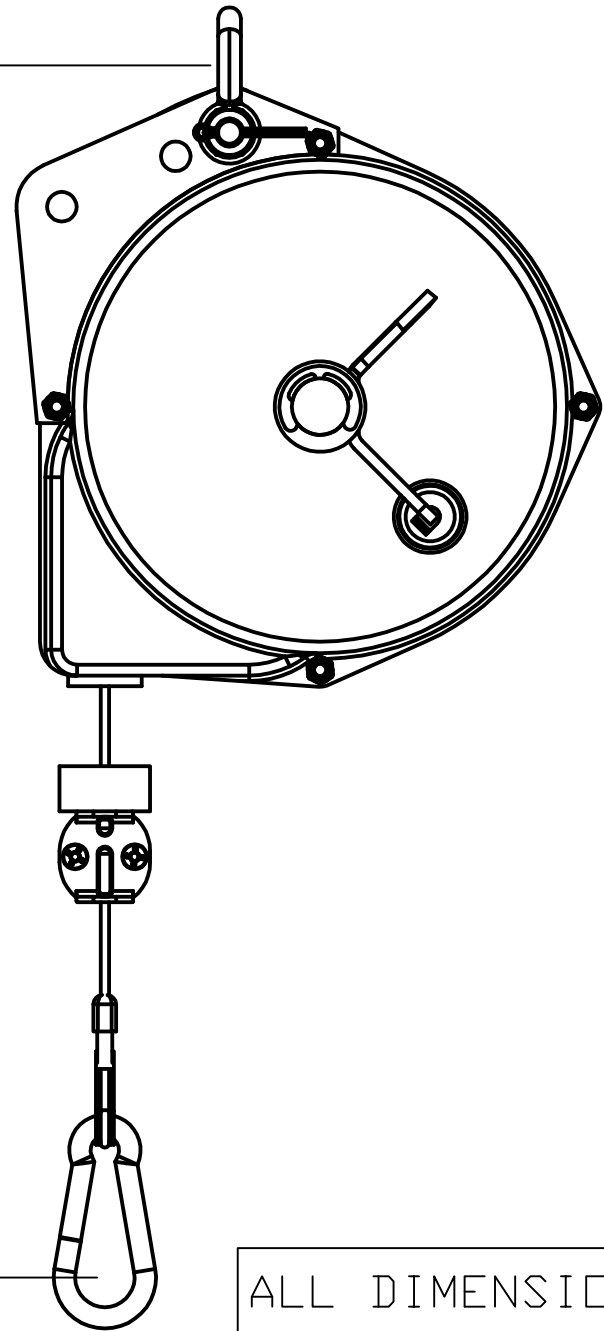
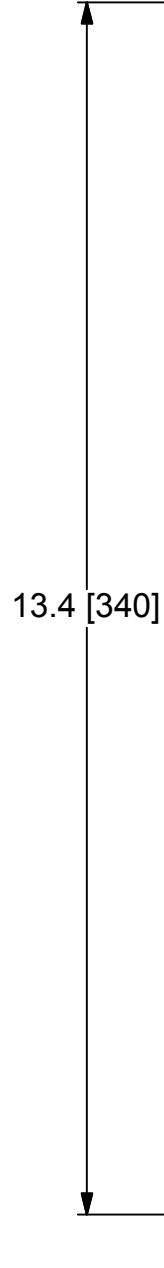
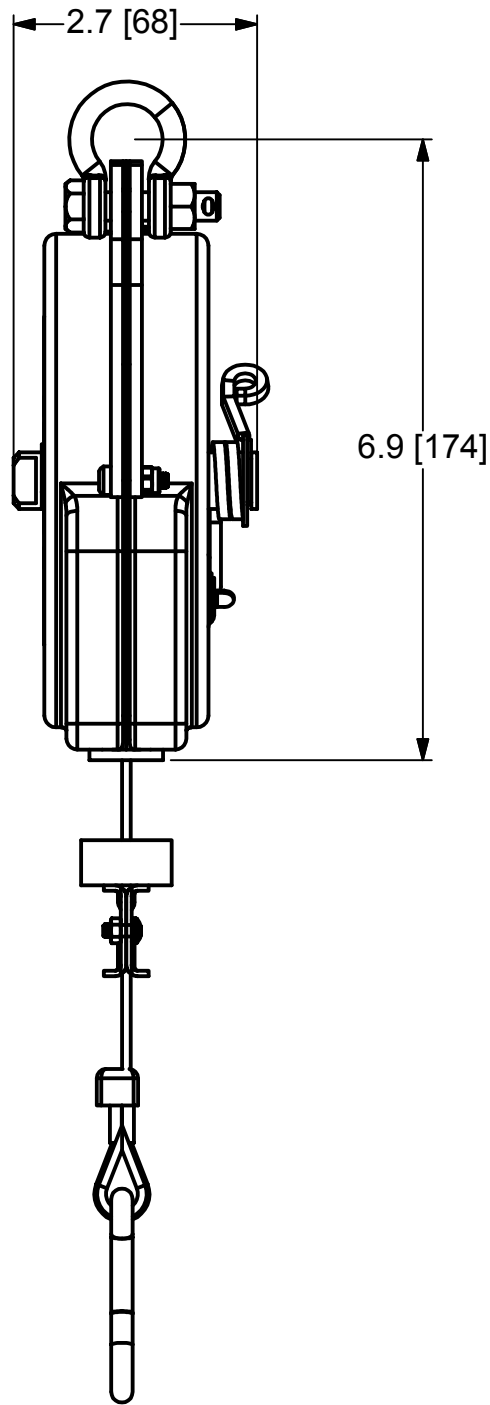
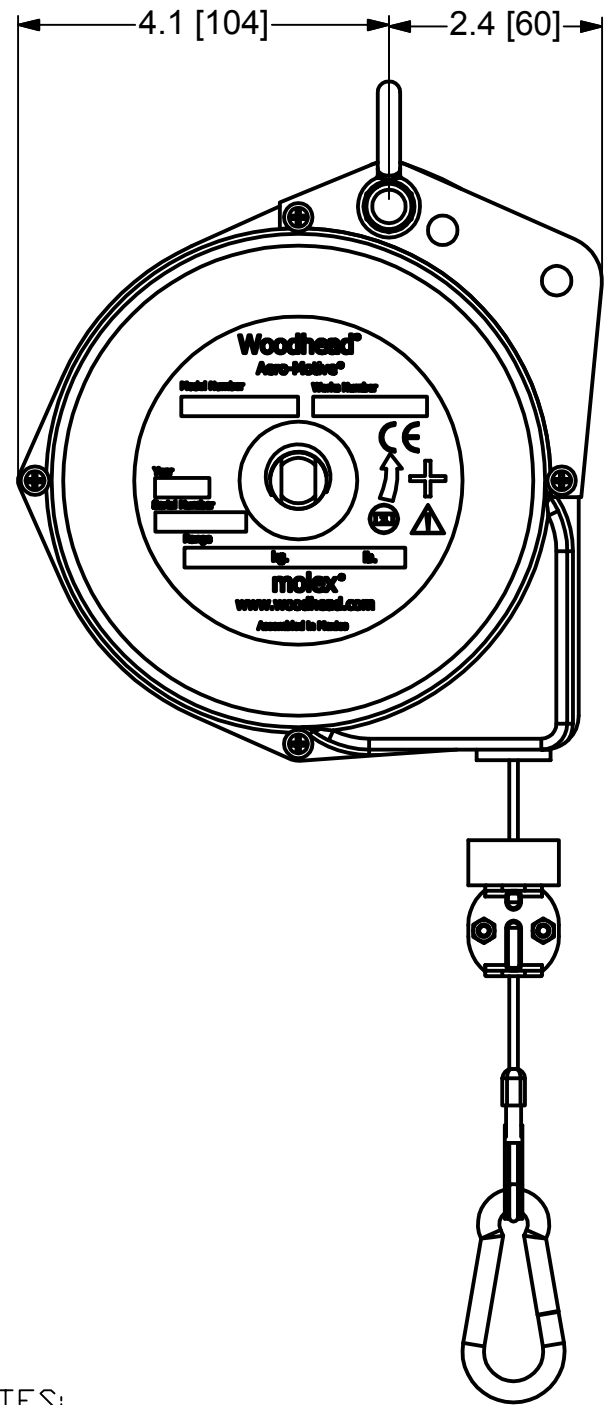

ALL DIMENSIONS ARE FOR REFERENCE ONLY.

- NOTES:
1. RETRACTORS ARE 100% INSPECTED & PRE-TENSIONED AT FACTORY.
  2. STEEL HOUSINGS HAVE A POWDER COATED FINISH TO MEET HARSH INDUSTRIAL ENVIRONMENTS.
  3. ALWAYS READ INSTRUCTIONS MANUAL BEFORE USING RETRACTORS.
  4. RETRACTORS ARE NOT TO BE USED AS BALANCERS THEIR MAIN PURPOSE BEING TO RETRACT A LOAD AND NOT TO BALANCE ONE.
  5. STANDARD RETRACTORS DO NOT COME EQUIPPED WITH A SAFETY CHAIN. IF APPLICATION REQUIRES A SAFETY CHAIN ADD "SC" SUFFIX TO STANDARD PART NUMBER. EXAMPLE 5FSC.
  6. WHEN MOUNTING RETRACTOR, ALWAYS MAKE SURE THAT SAFETY PIN WHICH COMES WITH SHACKLE IS INSTALLED & SECURED.

RELEASE TO SALES EC NO: WNA2009-0423 DRWN: RHOTCA CHKD: DT APPR: DITUS	9/17/09 2009/09/17 2009/09/25	DESCRIPTION REV	QUALITY SYMBOLS ▽=0 ▽=0	GENERAL TOLERANCES (UNLESS SPECIFIED)		DIMENSION STYLE IN/MM		SCALE NTS	DESIGN UNITS INCH	THIRD ANGLE PROJECTION
				mm	INCH	DRAWN BY	DATE	TITLE		
				4 PLACES	±NA	±NA	RH	2009/02/19	5F SERIES RETRACTORS AERO-MOTIVE	
				3 PLACES	±NA	±NA	DT	2009/02/19		
2 PLACES	±NA	±.05	APPROVED BY		DATE	MOLEX MOLEX INCORPORATED				
1 PLACE	±2.5	±.1	DTITUS	2009/09/24	DOCUMENT NO.					
DRAFT WHERE APPLICABLE MUST REMAIN WITHIN DIMENSIONS				ANGULAR ±1°		MATERIAL NO. SEE TABLE		SD-130175-001	SHEET NO. 1 OF 2	
THIS DRAWING CONTAINS INFORMATION THAT IS PROPRIETARY TO MOLEX INCORPORATED AND SHOULD NOT BE USED WITHOUT WRITTEN PERMISSION										

RETRACTOR MODEL:		ITEM #1:	ITEM #2:	CABLE ASSEMBLY USED BY EACH MODEL:		ITEM 17 SAFETY CHAIN USAGE IN ASSEMBY:		RETRACTOR OUTER COLOR
MATERIAL NUMBER	ENGINEERING NUMBER	MATERIAL NUMBER	MATERIAL NUMBER	MATERIAL NUMBER	ENGINEERING NUMBER	MATERIAL NUMBER	ENGINEERING NUMBER	
1301750014	5F	1301790778	1302344703	1301790136	9857-1	N/A	N/A	BLUE
1301750019	5FSC	1301790778	1302344703	1301790136	9857-1	1302264680	H13760001UK	BLUE

THIS LABEL IS DEPENDENT ON THE PLANT WHERE RETRACTOR IS BUILD & CUSTOMER THAT IS BUILT FOR. THUS POLAND PLANT WILL USE ONLY "ASSEMBLED IN POLAND" AND MEXICO PLANT WILL USE ONLY "ASSEMBLED IN MEXICO". CONTACT PLANT FOR SPECIFIC ITEM NUMBERS FOR THESE LABELS.

LOAD CAPACITY CHART:			
RETRACTOR MODEL:		EACH RETRACTOR IS 100% TESTED UNDER THIS WEIGHT:	
MATERIAL NUMBER	ENGINEERING NUMBER	IN LBS:	IN KGS:
1301750016	5FLR	5	2.3
1301750017	5FLRNC	5	2.3

ITEM	MATERIAL NUMBER	ENGINEERING NUMBER	ITEM DESCRIPTION
1	SEE CHART	SEE CHART	5F HSNG SPRING SIDE - POWDER XXX
2	SEE CHART	SEE CHART	5F HSNG PLAIN SIDE - POWDER XXX
3	1301790141	9882	ASSY SPRING & CABLE DRUM FOR 5F
4	1301790130	9806	CABLE DRUM SPACER
5	1302344673	14099	WASHER -.63 I.D.x.88 O.D.x.02 W - BZP
6	1301790017	13611	TENSION LOCK SPRING
7	N/A	N/A	ROUND LABEL- SEE PLANT FOR INFO
8	1302344666	13613	GUIDE - CABLE OUTLET
9	1301790136	9857-1	ASSY CABLE FOR 5F, 2.5M LONG
10	1302264648	1240-P-10	TOP SHACKLE ASSY WITH SAFETY PIN
11	1302344711	AG14613	SCREW M4X16Lg Posi PHEAD BZP
12	1302344710	AG14612	SCREW M4X10LG Posi PHEAD BZP
13	1302344690	580-P-35	EXTERNAL CIRCLIP 0.625" SHAFT
14	1302344713	AG14615	M4 NYLOC NUT
15	1302344704	AG10310	RET RING-ANDERTON N1500-62:BZP
16	1302261716	M62730003	HANGER BRACKET - 5F BALANCER
17	SEE CHART	SEE CHART	SAFETY CABLE - SEE CHART

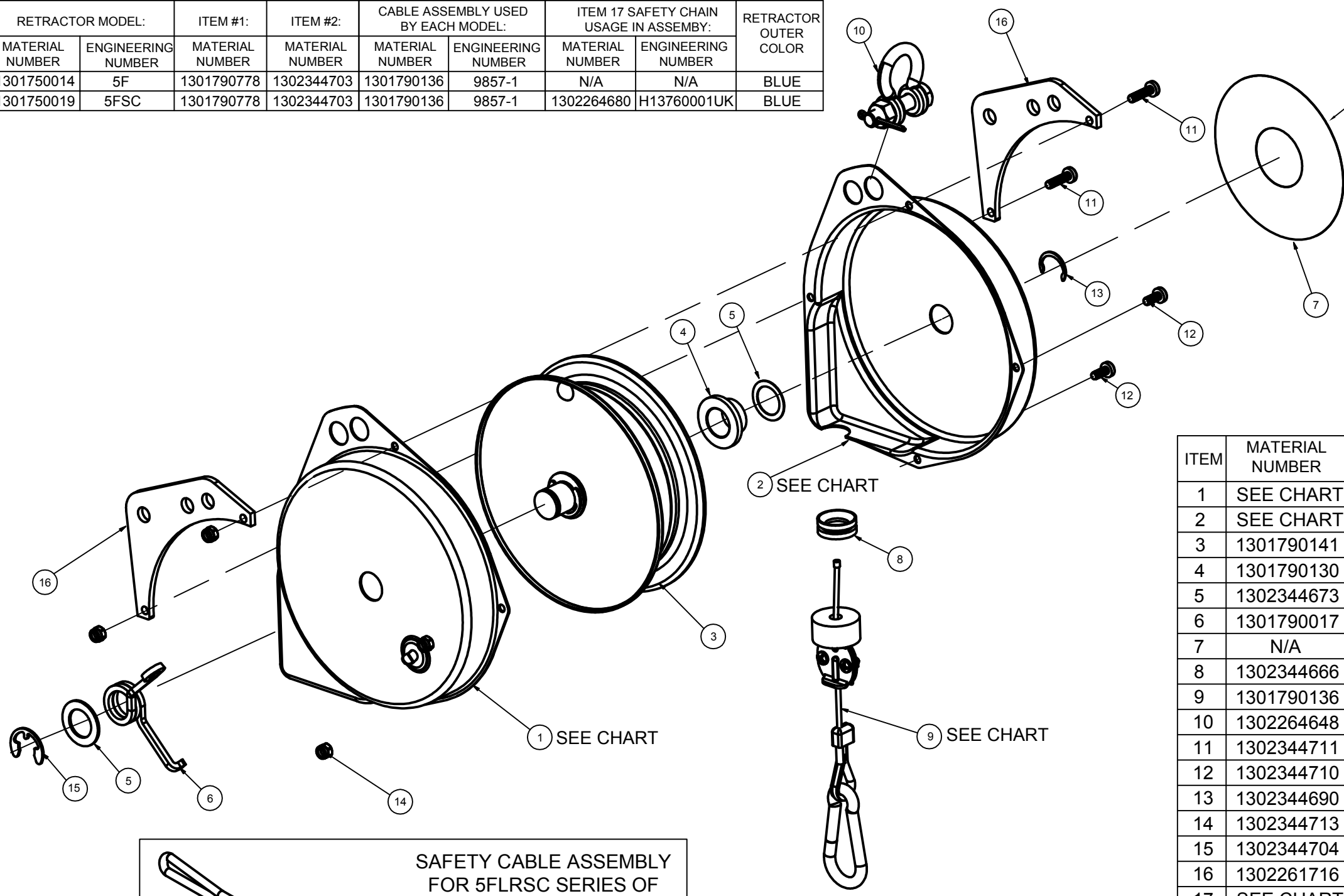

**SAFETY CABLE ASSEMBLY FOR 5FLRSC SERIES OF RETRACTORS**

MATERIAL NUMBER	ENGINEERING NUMBER
1302264680	H13760001UK

RELEASE TO SALES EC NO: WNA2009-0423 DRWN: RHOTCA CHKD: DT APPR: DTTITUS 9/17/09 2009/09/17 2009/09/25	QUALITY SYMBOLS ▽=0 ▽=0	<b>GENERAL TOLERANCES (UNLESS SPECIFIED)</b>		DIMENSION STYLE <b>IN/MM</b>		SCALE NTS	DESIGN UNITS INCH	THIRD ANGLE PROJECTION
		4 PLACES ±NA ±NA 3 PLACES ±NA ±NA 2 PLACES ±NA ±.05 1 PLACE ±2.5 ±.1	DRAWN BY: <b>RH</b> DATE: <b>2009/02/19</b>		TITLE <b>5F SERIES RETRACTORS AERO-MOTIVE</b>			
		ANGULAR ±1°		CHECKED BY: <b>DT</b> DATE: <b>2009/02/19</b>		MOLEX <b>MOLEX INCORPORATED</b>		
		<b>DRAFT WHERE APPLICABLE MUST REMAIN WITHIN DIMENSIONS</b>		APPROVED BY: <b>DTITUS</b> DATE: <b>2009/09/24</b>			DOCUMENT NO. <b>SD-130175-001</b>	
MATERIAL NO. <b>SEE TABLE</b>		THIS DRAWING CONTAINS INFORMATION THAT IS PROPRIETARY TO MOLEX INCORPORATED AND SHOULD NOT BE USED WITHOUT WRITTEN PERMISSION						

## X-ON Electronics

Largest Supplier of Electrical and Electronic Components

*Click to view similar products for [Cable Mounting & Accessories](#) category:*

*Click to view products by [Molex](#) manufacturer:*

Other Similar products are found below :

[582603-1](#) [009333-000](#) [727844N003](#) [747](#) [809090N001](#) [843188-000](#) [8666](#) [967279N002](#) [DB-11](#) [1300840039](#) [1300900096](#) [1301800416](#)  
[1302264450](#) [1300830184](#) [1300830729](#) [1300900039](#) [1301580036](#) [1301850553](#) [1301860939](#) [1302000074](#) [1302261315](#) [1302264431](#)  
[1337706-2](#) [APA18-AK](#) [1724](#) [1-787307-1](#) [185491N001](#) [1868](#) [HP-6N](#) [C-202-C](#) [202C221-13-0](#) [CA7308-000](#) [8S23-75FR-CS8184](#) [2684](#) [9648](#)  
[3089](#) [988382-000](#) [A72821-000](#) [AA401](#) [173506-000](#) [1823](#) [202C292-13-0](#) [202C302-13-0](#) [2109](#) [300625](#) [3330](#) [3412](#) [M9142](#) [M9143](#) [529732-000](#)