

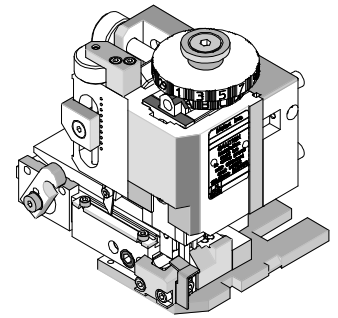

# FineAdjust Applicator Specification Sheet Order No. 63901-2600



## FEATURES

- Directly adapts to most automatic wire processing machines
- Quick punch removal with the push of a button for fast and easy tooling change
- Applicator designed to industry standard mounting and shut height 135.80mm (5.346")
- Quick set-up time; plus the crimp height, track and feed adjustments can be set without removing the applicator from the press
- Fine adjustment allows users to achieve target with little effort by adjusting in increments of .015mm (.0006") for conductor crimp height and .063mm (.0025") for insulation height
- Independent adjustment rings allow users to quickly adjust the conductor or insulation crimp height without affecting each other

## SCOPE

Products: Sabre™ Flat Blade Crimp Terminal-18-20 AWG, UL1015 wires.

Terminal Series No.	Terminal Order No.	Wire Size		★ Insulation Diameter		Strip Length	
		AWG	mm <sup>2</sup>	mm	In.	mm	In.
43374	43374-2001	18-20	0.80-0.50	2.54-2.85	.100-.112	3.96-5.54	.156-.218
43375	43375-2001	18-20	0.80-0.50	2.54-2.85	.100-.112	3.96-5.54	.156-.218

★ Insulation crimp to meet IPC/WHMA-A-620 Class 2 compliance.  
 Note: Terminal will accommodate the UL1015 wires.  
 For UL1007 wires use Applicator 63901-2500.

## DEFINITION OF TERMS

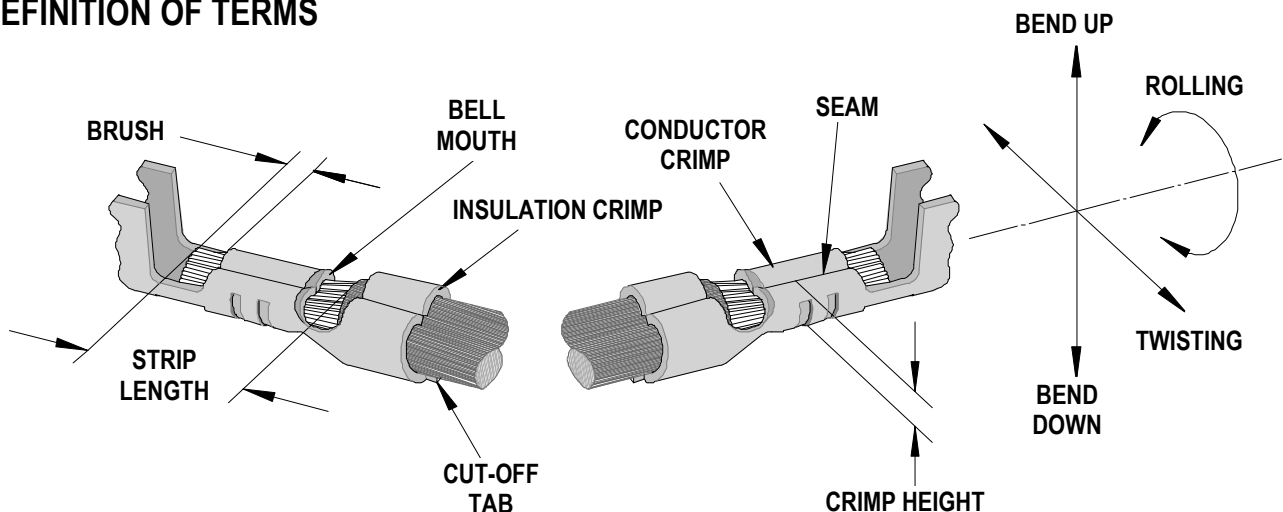

The above terminal drawing is a generic terminal representation. It is not an image of any terminal listed in the scope.

### CRIMP SPECIFICATION

Terminal Series No.	Bell mouth		Cut-off Tab Maximum		Conductor Brush Maximum	
	mm	In.	mm	In.	mm	In.
43374	0.20-0.50	.008-.020	0.30	.012	0.76	.030
43375						

Terminal Series No.	Bend up	Bend down	Twist	Roll	Punch Width (Ref)				Seam
					Conductor		Insulation		
	Degree (Max)		Degree (Max)		mm	In	mm	In	
43374	3	3	4	8	2.00	.079	3.20	.126	Seam shall not be open and no wire allowed out of the crimping area
43375									

After crimping, the conductor profile should measure the following.

Terminal Series No.	Wire Size		Conductor Crimp Height		Insulation Crimp Height (Ref)		Pull Force Minimum	
	AWG	mm <sup>2</sup>	mm	In.	mm	In.	N	Lb.
43374	18	0.80	1.16-1.26	.046-.050	3.00	.118	89.0	20.00
	20	0.50	1.10-1.20	.043-.047	2.80	.110	57.9	13.00
43375	18	0.80	1.16-1.26	.046-.050	3.00	.118	89.0	20.00
	20	0.50	1.10-1.20	.043-.047	2.80	.110	57.9	13.00

Pull Force should be measured with no influence from the insulation crimp.  
 The above specifications are guidelines to an optimum crimp.

**PARTS LIST**

<b>FineAdjust Applicator 63901-2600</b>				
<b>Item</b>	<b>Order No</b>	<b>Engineering No.</b>	<b>Description</b>	<b>Quantity</b>
<b>Perishable Tooling</b>				
	63901-2670	63901-2670	Tool Kit (All "Y" Items)	REF
1	63444-2025	63444-2025	Conductor Punch	1 Y
2	63445-2055	63445-2055	Conductor Anvil	1 Y
3	63446-3231	63446-3231	Insulation Punch	1 Y
4	63445-3250	63445-3250	Insulation Anvil	1 Y
5	63443-0035	63443-0035	Cut-Off Plunger	1 Y
6	63443-0036	63443-0036	Front Plunger Retainer	1 Y
<b>Other Components</b>				
7	11-18-4083	60707-8	Feed Guide	1
8	63443-0009	63443-0009	Scrape Chute	1
9	63443-0024	63443-0024	Key	1
10	63443-0090	63443-0090	Wire Stop	1
11	63443-1719	63443-1719	18.90mm Spacer	1
12	63443-2215	63443-2215	15.00mm Spacer	1
13	63443-2302	63443-2302	3.10mm Spacer	1
14	63443-2801	63443-2801	Front Plunger Striker	1
15	63443-2913	63443-2913	Wire Hold Down Plunger	1
16	63443-6121	63443-6121	Rear Cover	1
17	63600-1057	63600-1057	Striker Plunger Spring	1
18	63700-0539	63700-0539	Cut-off Plunger Spring	1
<b>Frame</b>				
19	63800-4901	63800-4901	Top	1
20	63801-3281	63801-3281	Base	1
21	63801-4650	63801-4650	Track	1
<b>Hardware</b>				
22	N/A	N/A	M3 by 6 Long SHCS	2**
23	N/A	N/A	M3 by 6 Long FHCS	1**
24	N/A	N/A	M4 by 6 Long SHCS	2**
25	N/A	N/A	M4 by 12 Long BHCS	2**
26	N/A	N/A	M4 by 50 Long SHCS	2**
27	N/A	N/A	M5 by 12 Long SHCS	1**
28	N/A	N/A	#10-32 by 3/8" Long Flat Point SSS	1**
29	N/A	N/A	#10-32 Hex Jam Nut	1**
** Available from an industrial supply company such as MSC (1-800-645-7270).				

# Assembly Drawing

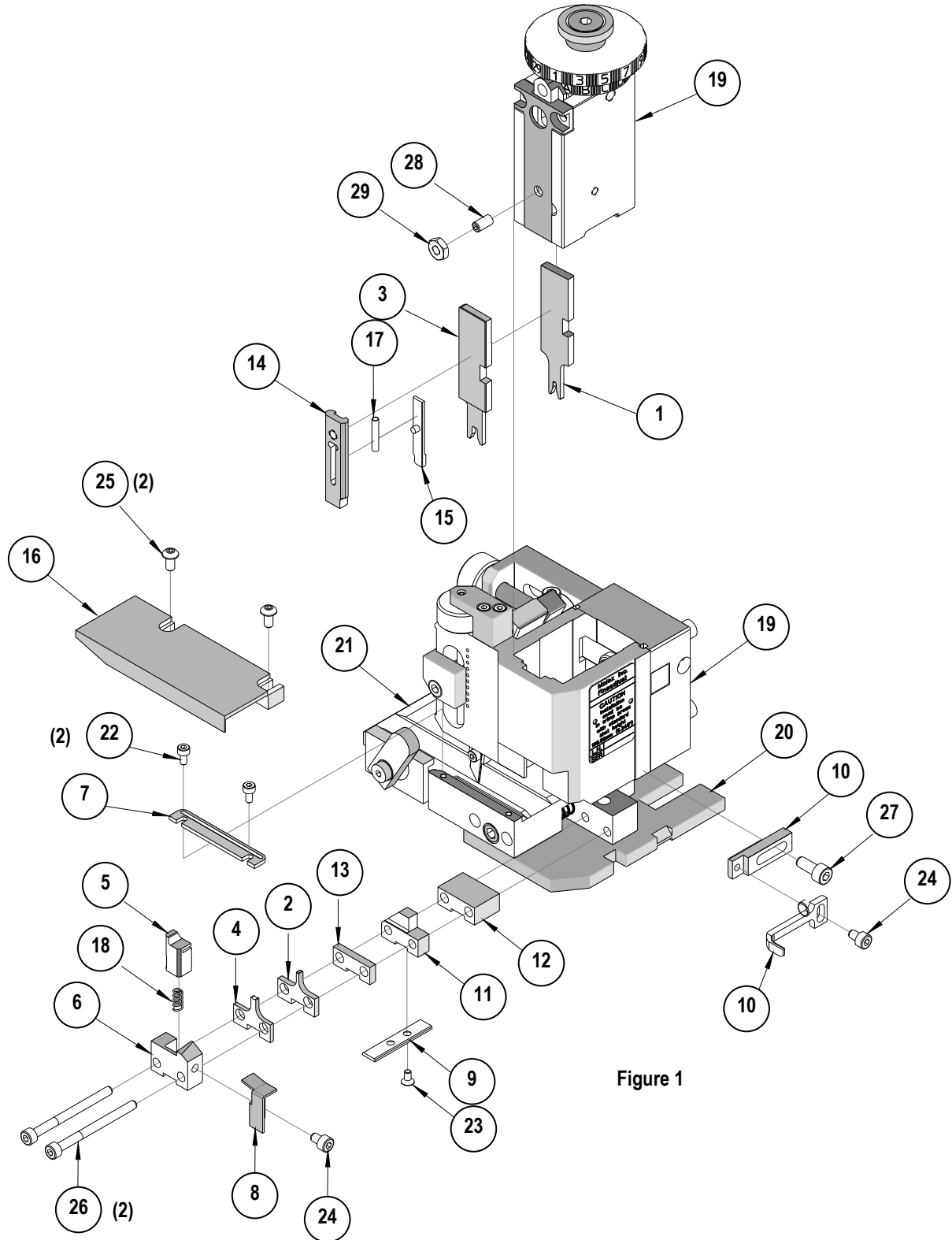

Figure 1

## NOTES

1. Molex recommends an extra perishable tooling kit be maintained at your facility.
2. Verify tooling alignment by manually cycling the press and Applicator before crimping under power. Check that all screws are tight.
3. Slugs, Terminals, Dirt and Oil should be kept clear of work area.
4. Wear safety glasses at all times.
5. For recommended maintenance refer to the FineAdjust Manual.

**CAUTION:** This applicator should only be used in a press with a shut height of 135.8mm (5.346"). Tooling damage could result at a lower setting.

**CAUTION:** To prevent injury never operate this Applicator without the guards supplied with the press or wire-processing machine in place. Reference the press or wire processing manufacturer's instruction manual.

**CAUTION:** Molex crimp specifications are valid only when used with Molex terminals, applicators and tooling.

**Americas Headquarters**  
Lisle, Illinois 60532 U.S.A.  
1-800-78MOLEX  
amerinfo@molex.com

**Far East North Headquarters**  
Yamato, Kanagawa, Japan  
81-462-65-2324  
feninfo@molex.com

**Far East South Headquarters**  
Jurong, Singapore  
65-6-268-6868  
fesinfo@molex.com

**European Headquarters**  
Munich, Germany  
49-89-413092-0  
eurinfo@molex.com

**Corporate Headquarters**  
2222 Wellington Ct.  
Lisle, IL 60532 U.S.A.  
630-969-4550  
Fax: 630-969-1352

Visit our Web site at <http://www.molex.com>

## X-ON Electronics

Largest Supplier of Electrical and Electronic Components

*Click to view similar products for [Punches & Dies](#) category:*

*Click to view products by [Molex](#) manufacturer:*

Other Similar products are found below :

[58510-1](#) [63454-1601](#) [63457-0056](#) [63457-3401](#) [730-5/8](#) [730BB-1-3/8](#) [734410](#) [PV-670508-001](#) [1328](#) [1338](#) [13782656](#) [13782673](#) [AR-19](#) [AR-24](#) [1528-TL](#) [1583609-1](#) [1720](#) [1762951-1](#) [2063500-2](#) [19031-0168](#) [AR-20](#) [AR-23](#) [CD5-8](#) [313336-3](#) [11-19-3122](#) [539663-1](#) [63446-2241](#) [TL-18](#) [0634451912](#) [1762674-1](#) [63454-0123](#) [68240-1](#) [68247-1](#) [734252](#) [313183-1](#) [PA2029](#) [119174-001](#) [23846-1](#) [11-40-5342](#) [68010-2](#) [690370015](#) [730BB-1-1/8](#) [730BB-1-1/16](#) [19032-0048](#) [63465-0023](#) [11-40-4438](#) [63457-0041](#) [19032-0202](#) [11-11-0054](#) [11-11-0052](#)