

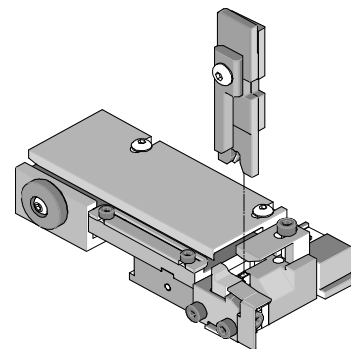

T2 Terminator Tooling Specification Sheet Order No. 63852-9200



FEATURES

- It is ideally suited for mid-volume bench operations
- This terminator can be installed in the TM42 and the TM40 press or Base Unit adapter for 3BF press
- Quick punch removal with the push of a button for fast and easy tooling change
- Track adjustment capabilities in the T2 Terminators for improved control of the bell mouth size and cutoff tab length
- T2 Terminator has standardized tooling with the Molex FineAdjust Applicator which will reduce your inventory requirements

SCOPE

Products: 1.80mm (.070") Board-In Terminal for 18 (2), 20 (2) AWG.

Terminal Series No.	Terminal Order No.	Wire Size		Insulation Diameter				Strip Length	
				IPC/WHMA-A620 ♦		Terminal Maximum ♦♦			
		AWG	mm ²	mm	In.	mm	In.	mm	In.
35745	35745-0310	18 (2)-20 (2)	0.80 (2)-0.50 (2)	2.50-2.80	.098-.110	2.80 (2)	.110 (2)	4.00-4.80	.157-.189
35746	35746-0310	18 (2)-20 (2)	0.80 (2)-0.50 (2)	2.50-2.80	.098-.110	2.80 (2)	.110 (2)	4.00-4.80	.157-.189
35747	35747-0310	18 (2)-20 (2)	0.80 (2)-0.50 (2)	2.50-2.80	.098-.110	2.80 (2)	.110 (2)	4.00-4.80	.157-.189
35748	35748-0310	18 (2)-20 (2)	0.80 (2)-0.50 (2)	2.50-2.80	.098-.110	2.80 (2)	.110 (2)	4.00-4.80	.157-.189

♦ To achieve optimum IPC-A620 insulation crimps, use this insulation OD range.
♦♦ Overall insulation OD specification for terminal.

DEFINITION OF TERMS

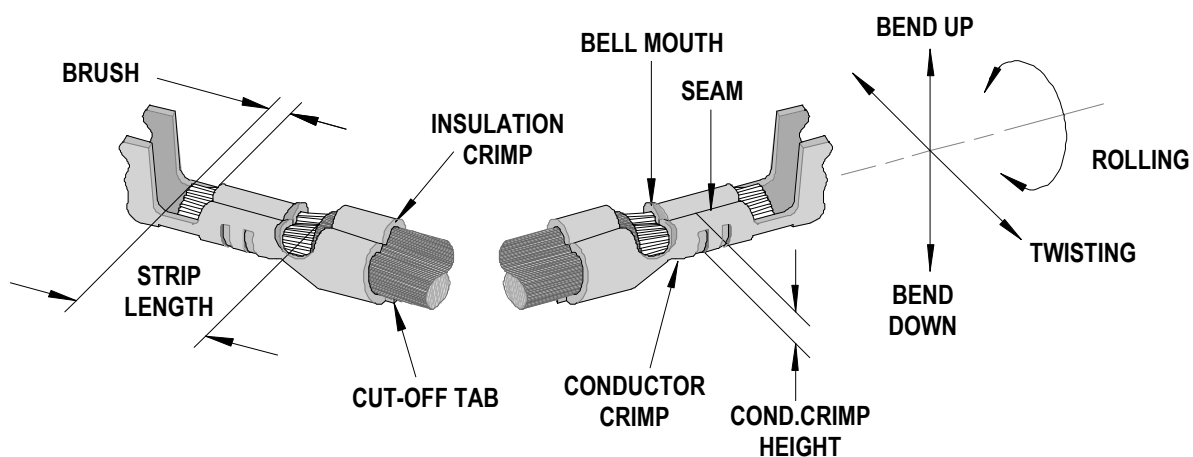

The above terminal drawing is a generic terminal representation. It is not an image of a terminal listed in the scope.

CRIMP SPECIFICATION

Terminal Series No.	Bell mouth		Cut-off Tab Maximum		Conductor Brush	
	mm	In.	mm	In.	mm	In.
35745	0.20-0.50	.008-.020	0.30	.012	0.30-0.80	.012-.032
35746	0.20-0.50	.008-.020	0.30	.012	0.30-0.80	.012-.032
35747	0.20-0.50	.008-.020	0.30	.012	0.30-0.80	.012-.032
35748	0.20-0.50	.008-.020	0.30	.012	0.30-0.80	.012-.032

Terminal Series No.	Bend up	Bend down	Twist	Roll	Punch Width (Ref)				Seam
					Conductor		Insulation		
	Degree		Degree		mm	In	mm	In	
35745	3	3	3	5	3.00	.118	5.30	.209	Seam shall not be open and no wire allowed out of the crimping area
35746	3	3	3	5	3.00	.118	5.30	.209	
35747	3	3	3	5	3.00	.118	5.30	.209	
35748	3	3	3	5	3.00	.118	5.30	.209	

After crimping, the conductor profile should measure the following.

Terminal Series No.	Wire Size		Conductor				Pull Force Minimum	
			Crimp Height		Crimp Width (Ref.)			
	AWG	mm ²	mm	In.	mm	In.	N	Lb.
35745	18 (2)	0.80 (2)	1.45-1.55	.057-.061	2.90-3.10	.114-.122	97.9	22.0
	20 (2)	0.50 (2)	1.35-1.45	.053-.057	2.90-3.10	.114-.122	58.7	13.2
35746	18 (2)	0.80 (2)	1.45-1.55	.057-.061	2.90-3.10	.114-.122	97.9	22.0
	20 (2)	0.50 (2)	1.35-1.45	.053-.057	2.90-3.10	.114-.122	58.7	13.2
35747	18 (2)	0.80 (2)	1.45-1.55	.057-.061	2.90-3.10	.114-.122	97.9	22.0
	20 (2)	0.50 (2)	1.35-1.45	.053-.057	2.90-3.10	.114-.122	58.7	13.2
35748	18 (2)	0.80 (2)	1.45-1.55	.057-.061	2.90-3.10	.114-.122	97.9	22.0
	20 (2)	0.50 (2)	1.35-1.45	.053-.057	2.90-3.10	.114-.122	58.7	13.2

Pull Force should be measured with no influence from the insulation crimp.

The above specifications are guidelines to an optimum crimp.

PARTS LIST

Terminator 63852-9200				
Item	Order No	Engineering No.	Description	Quantity
Perishable Tooling				
	63852-9270	63852-9270	Tool Kit (All "Y" Items)	REF
1	63444-3012	63444-3012	Conductor Punch	1 Y
2	63445-3068	63445-3068	Conductor Anvil	1 Y
3	63446-5309	63446-5309	Insulation Punch	1 Y
4	63445-5306	63445-5306	Insulation Anvil	1 Y
5	63443-0002	63443-0002	Cut-Off Plunger	1 Y
6	63443-0012	63443-0012	Front Plunger Retainer	1 Y
Other Components (REF 529050)				
7	11-18-4083	60707-8	Front Cover	1
8	11-24-1067	4996-4	Cut-off Plunger Spring	1
9	63443-3160	63443-3160	Front Plunger Striker	1
10	63443-0009	63443-0009	Scrape Chute	1
11	63443-0021	63443-0021	Lower Tooling Key	1
12	63443-2415	63443-2415	Anvil Mount	1
13	63443-4006	63443-4006	Wire Stop	1
14	63443-6011	63443-6011	Rear Cover	1
Frame				
15	63800-8500	63800-8500	T2 Terminator	1
Hardware				
16	N/A	N/A	M3 by 6 Long SHCS	2**
17	N/A	N/A	M4 by 6 Long SHCS	1**
18	N/A	N/A	M4 by 10 Long BHCS	2**
19	N/A	N/A	M4 by 20 Long SHCS	1**
20	N/A	N/A	M4 by 50 Long SHCS	1**
21	N/A	N/A	M4 by 16 Long SHCS	1**
22	N/A	N/A	3mm by 6 Long Roll Pin	1**
23	N/A	N/A	#10-32 by 3/8" Long BHCS	1**
** Available from an industrial supply company such as MSC (1-800-645-7270).				

Assembly Drawing

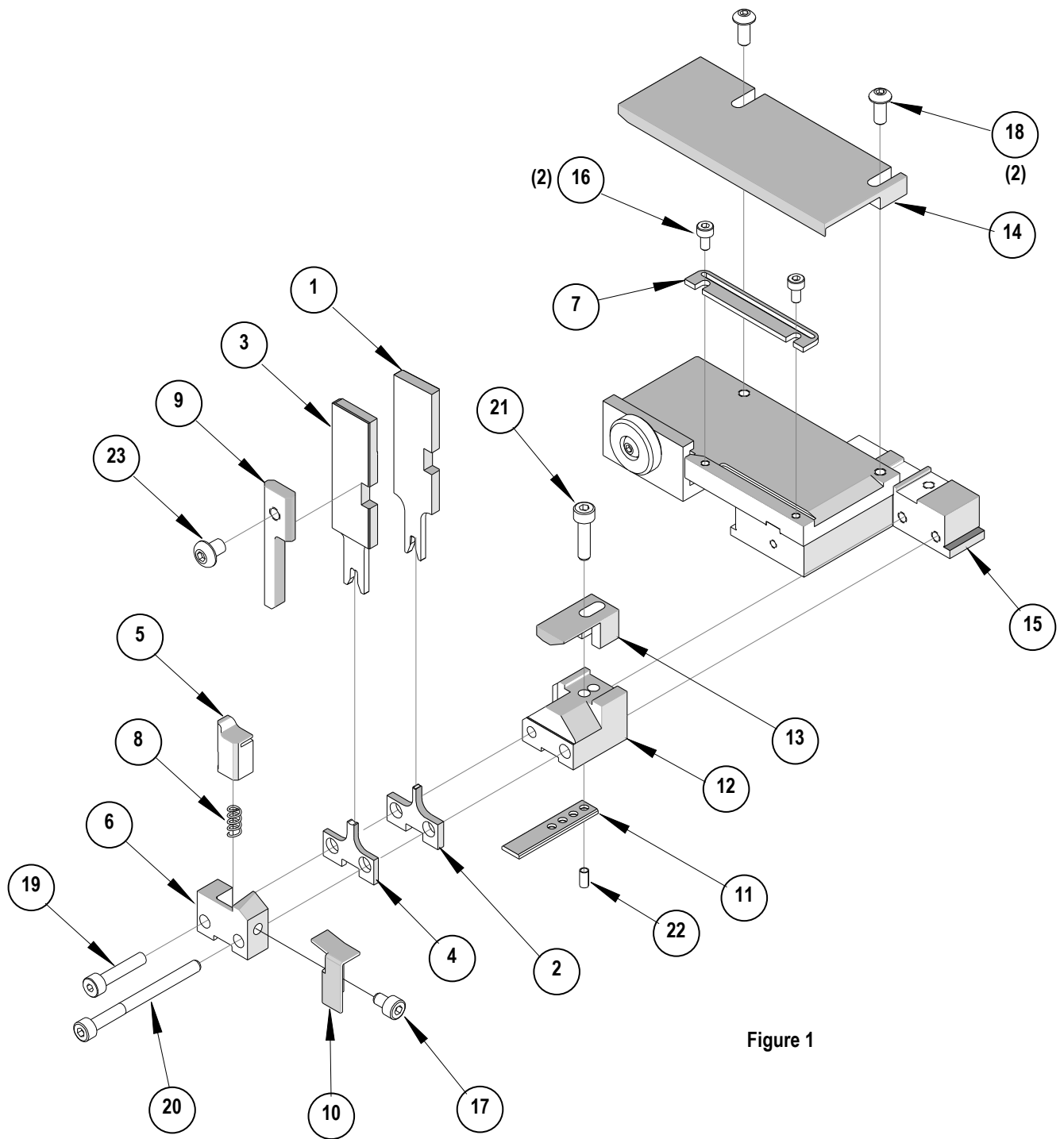

Figure 1

NOTES

Depending on the press vintage a feed finger assembly is supplied with the T2 Terminator.

1. To remove the existing feed finger assembly loosens the M4 x 10 mm set screw in the feed lever.
2. Select T2 Feed finger assembly from Terminator box.
3. Insert a screwdriver into the slot behind the feed lever and force the feed arm spring to the right.
4. Slide the T2 feed finger shaft for TM42 (11-40-5307) or (11-40-0123) for TM40 /Base Unit into the feed lever and to the left of the feed arm spring.
5. Release the feed arm spring.
6. Position feed finger for selected product. (Refer to Figure 5.1 in the T2 Manual).

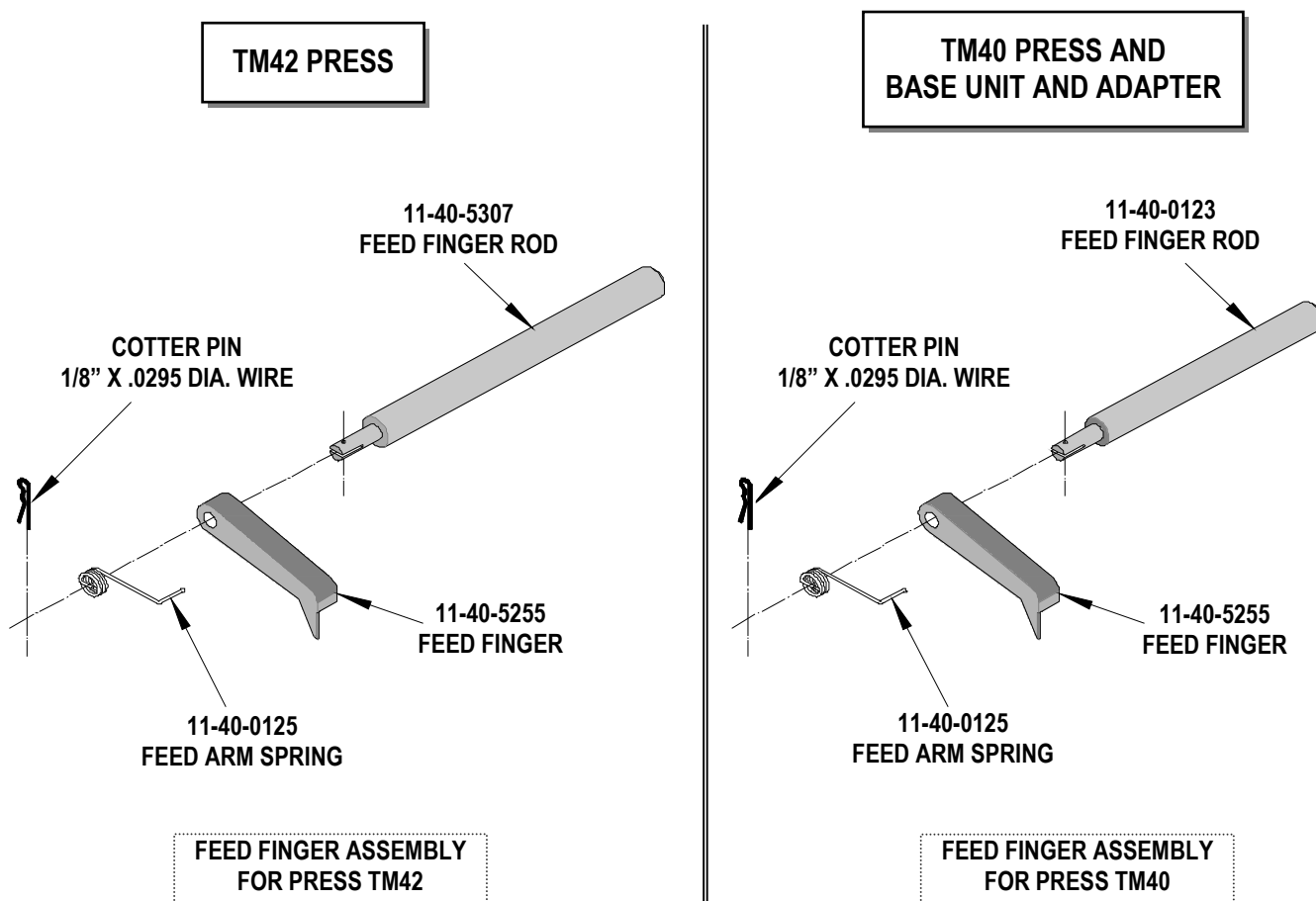

Figure 2

NOTES

1. Molex recommends an extra perishable tooling kit be maintained at your facility.
2. Verify tooling alignment by manually cycling the press before crimping under power. Check that all screws are tight.
3. Slugs, Terminals, Dirt and Oil should be kept clear of work area.
4. This Terminator should be only used in a Molex TM42, TM40, or 3BF Press with a Base Unit adaptor.
5. Wear safety glasses at all times.
6. For recommended maintenance refer to the TM40, TM42 Manual.

CAUTION: To prevent injury never operate this Terminator without the guards supplied with the press in place. Reference the TM42 press manufacturer's instruction manual.

CAUTION: Molex crimp specifications are valid only when used with Molex terminals, applicators and tooling.

Americas Headquarters
Lisle, Illinois 60532 U.S.A.
1-800-78MOLEX
amerinfo@molex.com

Far East North Headquarters
Yamato, Kanagawa, Japan
81-462-65-2324
feninfo@molex.com

Far East South Headquarters
Jurong, Singapore
65-6-268-6868
fesinfo@molex.com

European Headquarters
Munich, Germany
49-89-413092-0
eurinfo@molex.com

Corporate Headquarters
2222 Wellington Ct.
Lisle, IL 60532 U.S.A.
630-969-4550
Fax: 630-969-1352

Visit our Web site at <http://www.molex.com>

X-ON Electronics

Largest Supplier of Electrical and Electronic Components

Click to view similar products for [Tool Kits & Cases](#) category:

Click to view products by [Molex](#) manufacturer:

Other Similar products are found below :

[217434-1](#) [4263](#) [1055420-1](#) [11-18-3023](#) [63860-8170](#) [856600-2](#) [690372163](#) [11-40-3247](#) [63883-2870](#) [63885-0270](#) [63866-1070](#) [63863-5070](#)
[63892-7370](#) [11-18-3209](#) [63860-4070](#) [63881-0970](#) [A0403641](#) [11-18-3040](#) [63865-2070](#) [63910-1470](#) [63861-5070](#) [63850-7470](#) [11-18-3201](#)
[63910-7570](#) [FM 0501 146](#) [63883-0670](#) [63830-0070](#) [63902-9170](#) [11-18-3147](#) [11-18-3079](#) [63883-2670](#) [63900-1770](#) [11-18-3190](#) [63851-1070](#)
[63912-4770](#) [63911-5270](#) [63895-1070](#) [63860-1470](#) [63850-6070](#) [1-69411-3](#) [63852-9270](#) [63802-6270](#) [63902-4870](#) [11-18-3202](#) [63852-9170](#)
[63850-1070](#) [63830-0170](#) [63910-2870](#) [11-18-3010](#) [63820-7070](#)