

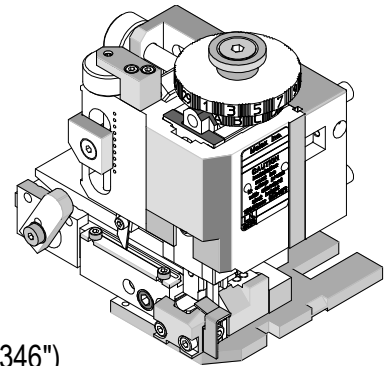

FineAdjust Applicator Specification Sheet Order No. 63901-5200



FEATURES

- Quick punch removal with the push of a button for fast and easy tooling change
- Applicator designed to industry standard mounting and shut height 135.80mm (5.346")
- Quick set-up time; plus the crimp height, track and feed adjustments can be set without removing the applicator from the press
- Fine adjustment allows users to achieve target with little effort by adjusting in increments of .015mm (.0006") for conductor crimp height and .063mm (.0025") for insulation height
- Independent adjustment rings allow users to quickly adjust the conductor or insulation crimp height without affecting each other
- Directly adapts to most automatic wire processing machines

SCOPE

Products: 2.00mm (.079") Pitch Female Crimp Terminal, 22-28 AWG.

Terminal Series No.	Terminal Order No.	Wire Size		Insulation Diameter				Strip Length	
				IPC/WHMA-A60 (1)		Terminal (2)			
		AWG	mm ²	mm	In.	mm	In.	mm	In.
56134	56134-8000	22	0.34	1.65	0.065	1.25-1.70	.049-.067	1.60-2.00	.063-.079
		24	0.20	1.45	0.057				
		26	0.13	1.30	0.051				
	56134-9000	22	0.34	1.65	0.065	0.90-1.70	.035-.067	1.60-2.00	.063-.079
		24	0.20	1.45	0.057				
		26	0.13	1.30	0.051				
		28 (3)	-	-	-	-	-	-	

(1) To achieve optimum IPC-A620 Class 2 insulation crimps, use this insulation OD using UL1007 wire.
 (2) Overall insulation OD specification for terminal.
 (3) 28 AWG wire is not recommended for use in this terminal, use 22-26 AWG wire for better crimp quality.

DEFINITION OF TERMS

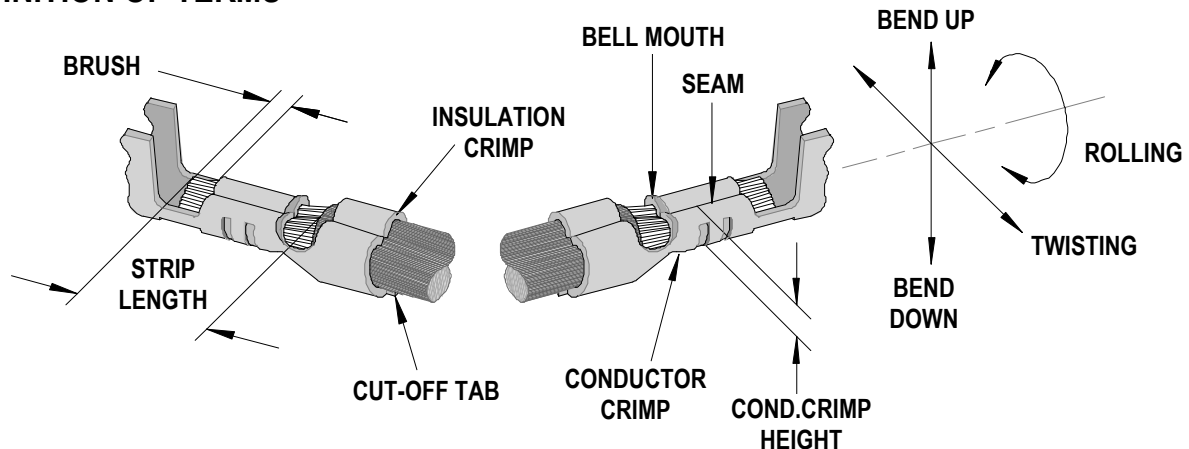

The above terminal drawing is a generic terminal representation. It is not an image of any terminal listed in the scope.

CRIMP SPECIFICATION

Terminal Series No.	Bell mouth		Cut-off Tab Maximum		Conductor Brush	
	mm	In.	mm	In.	mm	In.
56134	0.05-0.40	.002-.016	0.30	.012	0.10-0.70	.004-.028

Terminal Series No.	Bend up	Bend down	Twist	Roll	Punch Width (Ref)				Seam Seam shall not be open and no wire allowed out of the crimping area
	Degree		Degree		Conductor		Insulation		
	mm	In	mm	In	mm	In	mm	In	
56134	3 °	3 °	3 °	6 °	1.20	.047	1.50	.059	

After crimping, the crimp profiles should measure the following:

Terminal Order No.	Wire Size		Conductor				Insulation				Pull Force Minimum	
			Crimp Height		Crimp Width (Ref)		Crimp Height		Crimp Width (Ref)			
	AWG	mm ²	mm	In.	mm	In.	mm	In.	mm	In.	N	Lb.
56134-8000	22	0.34	0.70-0.75	.028-.030	1.18-1.28	.046-.050	1.85-1.95	.073-.077	1.55-1.75	.061-.069	44.1	9.9
	24	0.20	0.67-0.72	.026-.028	1.18-1.28	.046-.050	1.80-1.90	.071-.075	1.55-1.75	.061-.069	29.4	6.6
	26	0.13	0.61-0.66	.024-.026	1.18-1.28	.046-.050	1.75-1.85	.069-.073	1.55-1.75	.061-.069	19.6	4.4
56134-9000	22	0.34	0.70-0.75	.028-.030	1.18-1.28	.046-.050	1.85-1.95	.073-.077	1.55-1.75	.061-.069	44.1	9.9
	24	0.20	0.67-0.72	.026-.028	1.18-1.28	.046-.050	1.80-1.90	.071-.075	1.55-1.75	.061-.069	29.4	6.6
	26	0.13	0.61-0.66	.024-.026	1.18-1.28	.046-.050	1.75-1.85	.069-.073	1.55-1.75	.061-.069	19.6	4.4

T Tool Qualification Notes:

1. This Applicator was qualified to the above specifications with UL1007 wire.
*An insulation diameter larger than .051" may cause the insulation grips to pierce the insulation on both sides of the insulation crimp. The customer should determine the suitability for their application.
2. Pull Force should be measured with no influence from the insulation crimp.
3. The above specifications are guidelines to an optimum crimp.

PARTS LIST

FineAdjust Applicator 63901-5200				
Item	Order No	Engineering No.	Description	Quantity
Perishable Tooling				
	63901-5270	63901-5270	Tool Kit (All "Y" Items)	REF
1	63444-1207	63444-1207	Conductor Punch	1 Y
2	63445-1213	63445-1213	Conductor Anvil	1 Y
3	63446-1510	63446-1510	Insulation Punch	1 Y
4	63445-1504	63445-1504	Insulation Anvil	1 Y
5	63443-0002	63443-0002	Cut-Off Plunger Front	1 Y
6	63443-0012	63443-0012	Plunger Retainer Front	1 Y
Other Components				
7	11-18-4083	60707-8	Front Cover	1
8	11-24-1067	4996-4	Cut-off Plunger Spring	1
9	63443-0009	63443-0009	Scrap Chute Front	1
10	63443-0024	63443-0024	Lower Tooling Key	1
11	63443-0090	63443-0090	Wire Stop	1
12	63443-1703	63443-1703	17.30mm Height Spacer	1
13	63443-2210	63443-2210	10.0mm Coarse Spacer	2
14	63443-3160	63443-3160	Plunger Striker Front	1
15	63443-6111	63443-6111	Rear Cover	1
Frame				
16	63800-4901	63800-4901	Top	1
17	63801-3281	63801-3281	Base	1
18	63801-4650	63801-4650	Track	1
Hardware				
19	N/A	N/A	M3 by 6 Long FHCS	1**
20	N/A	N/A	M3 by 6 Long SHCS	2**
21	N/A	N/A	M4 by 6 Long SHCS	2**
22	N/A	N/A	M4 by 12 Long BHCS	2**
23	N/A	N/A	M4 by 45 Long SHCS	2**
24	N/A	N/A	M5 by 12 Long SHCS	1**
25	N/A	N/A	#10-32 by 3/8" Long Flat Point SSS	1**
26	N/A	N/A	#10-32 Hex Jam Nut	1**

** Available from an industrial supply company such as MSC (1-800-645-7270).

Assembly Drawing

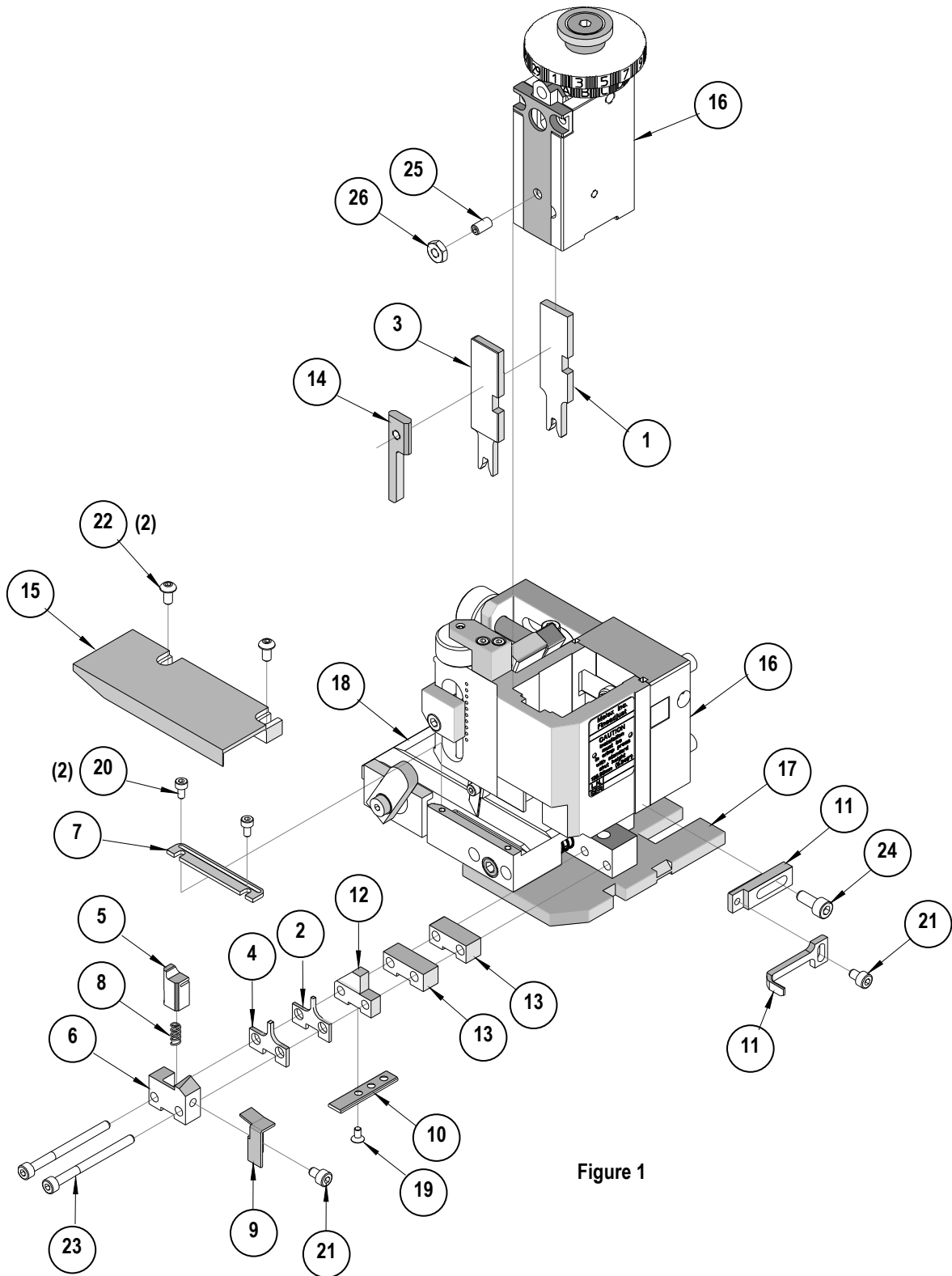

Figure 1

NOTES

1. Molex recommends an extra perishable tooling kit be maintained at your facility.
2. Verify tooling alignment by manually cycling the press and Applicator before crimping under power. Check that all screws are tight.
3. Slugs, Terminals, Dirt and Oil should be kept clear of work area.
4. Wear safety glasses at all times.
5. For recommended maintenance refer to the FineAdjust Manual.

CAUTION: This applicator should only be used in a press with a shut height of 135.80 mm (5.346"). Tooling damage could result at a lower setting.

CAUTION: To prevent injury never operate this Applicator without the guards supplied with the press or wire-processing machine in place. Reference the press or wire processing manufacturer's instruction manual.

CAUTION: Molex crimp specifications are valid only when used with Molex terminals, applicators and tooling.

Americas Headquarters
Lisle, Illinois 60532 U.S.A.
1-800-78MOLEX
amerinfo@molex.com

Far East North Headquarters
Yamato, Kanagawa, Japan
81-462-65-2324
feninfo@molex.com

Far East South Headquarters
Jurong, Singapore
65-6-268-6868
fesinfo@molex.com

European Headquarters
Munich, Germany
49-89-413092-0
eurinfo@molex.com

Corporate Headquarters
2222 Wellington Ct.
Lisle, IL 60532 U.S.A.
630-969-4550
Fax: 630-969-1352

Visit our Web site at <http://www.molex.com>

X-ON Electronics

Largest Supplier of Electrical and Electronic Components

Click to view similar products for [Tool Kits & Cases](#) category:

Click to view products by [Molex](#) manufacturer:

Other Similar products are found below :

[217434-1](#) [4263](#) [1055420-1](#) [11-18-3023](#) [63860-8170](#) [856600-2](#) [690372163](#) [11-40-3247](#) [63883-2870](#) [63885-0270](#) [63866-1070](#) [63863-5070](#)
[63892-7370](#) [11-18-3209](#) [63860-4070](#) [63881-0970](#) [A0403641](#) [11-18-3040](#) [63865-2070](#) [63910-1470](#) [63861-5070](#) [63850-7470](#) [11-18-3201](#)
[63910-7570](#) [FM 0501 146](#) [63883-0670](#) [63830-0070](#) [63902-9170](#) [11-18-3147](#) [11-18-3079](#) [63883-2670](#) [63900-1770](#) [11-18-3190](#) [63851-1070](#)
[63912-4770](#) [63911-5270](#) [63895-1070](#) [63860-1470](#) [63850-6070](#) [1-69411-3](#) [63852-9270](#) [63802-6270](#) [63902-4870](#) [11-18-3202](#) [63852-9170](#)
[63850-1070](#) [63830-0170](#) [63910-2870](#) [11-18-3010](#) [63820-7070](#)