

DESCRIPTION

The EV2632-R-01A is the evaluation board designed to demonstrate the capabilities of MPS' MP2632, a highly-integrated, flexible switch-mode battery charge management for a single-cell Li-ion and Li-Polymer battery used in a wide range of applications.

EV2632 uses two operating modes—charge mode and boost mode—to allow management of system and battery power based on the state of the input.

When input power is present, the board charges a single-cell battery with a programmable charge current of up to 3A.

In the absence of an input source, the board switches to boost mode through the PB pin to power the SYS pins from the battery with a current of up to 3A.

The evaluation board provides 4-LED to achieve the voltage based fuel gauge indication and distinguish charge mode from boost mode.

To guarantee safe operation, the EV2632 has input-over-voltage protection, battery over-voltage protection, thermal shutdown, battery-temperature monitoring, and a programmable timer to prevent prolonged charging of a dead battery.

ELECTRICAL SPECIFICATION

Parameter	Symbol	Value	Units
Charge Mode			
Input Voltage Range	V_{IN}	4.65 – 6	V
Charge-Full Voltage	V_{BATT_Full}	4.2 / 4.35 / 4.45	V
Charge Current	I_{CHG}	3	A
Input Current Limit	I_{IN_LIM}	2.7	A
Boost Mode			
Battery Voltage	V_{BATT}	3-4.5	V
SYS Voltage Regulation	V_{SYS}	5	V
SYS Output Current Limit	I_{SYS}	3	A

FEATURES

- 4.65V-to-6V Operating Input Voltage Range
- Power Management Function Integrated Input-Current-Limit and Input Voltage Regulation
- Up to 3A Programmable Charge Current
- Selectable 4.45V / 4.35V / 4.2V Charge Voltage with 0.5% Accuracy
- Battery Temperature Monitoring
- 4-LED for battery fuel gauge indication
- Programmable Timer Back-Up Protection
- Battery-Reverse-Leakage Blocking
- Reverse-Boost-Operation for Powering System
- Up to 94% 5V Boost Mode Efficiency @ 3A with BATT=4.5V
- Up to 3A Programmable Output Current Limit in Boost Mode

APPLICATIONS

- Sub-battery Applications
- Power-bank Applications for Smart-Phone, Tablet and Other Portable Devices

All MPS parts are lead-free, halogen free, and adhere to the RoHS directive. For MPS green status, please visit MPS website under Quality Assurance.

"MPS" and "The Future of Analog IC Technology" are Registered Trademarks of Monolithic Power Systems, Inc.

EV2632-R-01A EVALUATION BOARD



(L x W x H) 2.5" x 2.5" x 0.063"
(6.35cm x 6.35cm x 0.16cm)

Board Number	MPS IC Number
EV2632-R-01A	MP2632GR

EVALUATION BOARD SCHEMATIC

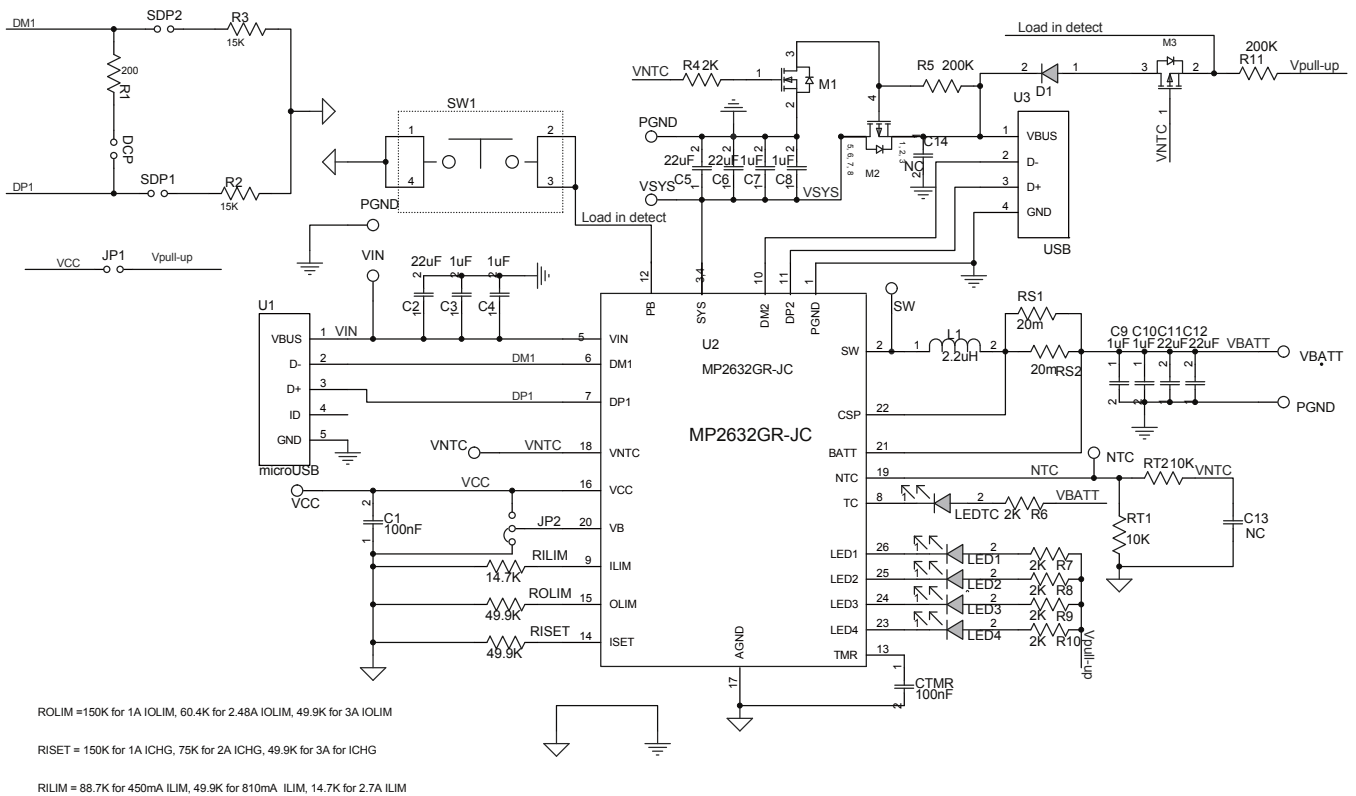

EV2632-R-01A BILL OF MATERIALS

Qty	Ref	Value	Description	Package	Manufacture	Manufacture_PN
1	R1	200	Film Resistor;1%	0603	Yageo	RC0603FR-07200RL
2	R2, R3	15k	Film Resistor;5%;	0603	Yageo	RC0603JR-0715KL
6	R4, R6, R7, R8, R9, R10	2k	Film Resistor;5%	0603	Yageo	RC0603JR-072KL
1	R5,R11	200k	Film Resistor;5%	0603	Yageo	RC0603JR-07200KL
2	RS1, RS2	20m	Resistor;1%;	2512	Yageo	RL2512FK-070R02L
2	RISSET, ROLIM	49.9k	Film Resistor;1%	0603	Yageo	RC0603FR-0749K9L
1	RILIM	14.7k	Film Resistor;1%	0603	Yageo	RC0603FR-0714K7L
2	RT1, RT2	10k	Film Resistor;5%;	0603	Yageo	RC0603JR-0710KL
2	C1, CTMR	100nF	Ceramic Capacitor;16V;X7R;0603	0603	TDK	C1608X7R1C104K
5	C2, C5, C6, C10, C12	22µF	Ceramic Capacitor;25V;X5R;	1206	muRata	GRM31CR61E226KE15
6	C3, C4, C7, C8, C9, C11	1µF	Ceramic Capacitor;25V;X7R	0603	TDK	C1608X7R1E105K
	C13, C14	NC				
1	LEDTC	CB-482QWC	LED; WLED,20mA,	DIP2		
4	LED1, LED2, LED3, LED4	BL-HGE35A-TRB	LED; Green	0805	BRIGHT LED	BL-HGE35A-TRB
1	D1	B130LAW	Schottky;30V;1A	SOD-123		B130LAW-7
1	M1	AM2336N	N-Channel MOSFET; 30V;	SOT-23	Analog Power	AM2336N
1	M2	AM4825P-T1	P-Channel MOSFET; -30V;	SO-8	Analog Power	AM4825-T1-PF
1	M3	AM2305	P-Channel MOSFET, 20V	SOT-23	Analog Power	AM2305PE-T1
1	L1	2.2µH	Inductor;2.2uH;0.173m;8.2A	SMD	TDK	SPM6530T-2R2M
1	SW1	Push Switching button	Button; SM 4x10mm;1.5mm Height			
1	U1	Micro-USB receptacle				
1	U2	MP2632	IC	QFN26 4*4	MPS	MP2632GR
1	U3	USB A-type receptacle				
6	VIN,PGND, VBATT, PGND,VSYS, PGND		2mm terminal			
4	DCP, JP1, SDP1, SDP2		Jumper, 2.54mm			

QUICK START GUIDE

This board is designed for the MP2632, a stand-alone switch-mode battery charge management and system power path management device with integrated reverse directional boost from BATT to SYS. The board' layout accommodates most commonly-used capacitors. The default function of this board is preset at charge mode, and the charge full voltage is preset to 4.35V for a 1-cell Li-Ion battery.

Charge Mode Setting

1. Input Current Limit

An input current limit can be set slightly below the input source's maximum current rating. When the input current hits this limit, the charge current will decrease to keep the input current constant at the limit value to initially power the system. R_{ILIM} —the resistor connected to the ILIM pin—programs this limit. To set the input current limit at 2.7A, use a R_{ILIM} of 14.7k Ω .

$$I_{ILIM}(A) = \frac{40(k\Omega)}{R_{ILIM}(k\Omega)} \quad (1)$$

2. Charge-Full Voltage

To set the charge-full voltage, leave the VB pin floating for 4.2V, connect VB to L for 4.35V and connect VB to H for 4.45V.

3. Charge Current

The charge current can be programmed via both RS1 and R_{ISET} . With given RS1=10m Ω , determine the charge current using the following formula:

$$I_{CHG}(A) = \frac{1500}{R_{ISET}(k\Omega) \times RS1(mA)} \quad (2)$$

For example, for a charge current of 3A, use a 49.9k Ω R_{ISET}

Boost Mode

1. System-Output-Current Limit

Set the system-output-current limit in boost mode for the EV2632 to operate like a standard USB charger. Set the output current limit as the following equation:

$$I_{OLIM}(A) = \frac{1500}{R_{OLIM}(k\Omega) \times RS1(m\Omega)} \quad (3)$$

2. BOOST Automatic On when Load is Applied

The load is applied to the USB port connected to the SYS output which is U3 in the schematic.

To detect the USB load plug in, the RC network (R11,C14) is connected to USB port (U3) shield (V_{BUS}) Once the USB load is inserted to the SYS through U3, the USB connector shield is grounded through USB load. So a short pulse (high to Low for >1.5ms) is generated in PB pin, resulting in start of boost operation. M2 is used to decouple USB port from the VSYS cap (C2, C_{SYS}), M1 is used to drive the M2. Once the Phone is plugged in, the voltage at C14 will be pulled down because the input cap inside phone is far larger than C14 (even don't need), so that the falling edge will be delivered to PB pin to enable boost automatically. M3 is used to cutoff the PB pin to the USB port when the BOOST is turned on. Then PB pin state will not be affect by the spec of the inserted load of the USB port. Choose M3 with low turning on threshold (-0.7V is recommended) which could make sure it is fully on when the load is inserted and its on resistance will not cause too much voltage drop.

For the other detailed description on the operation of the MP2632, please refer to the datasheet.

EQUIPMENT REQUIREMENT

Evaluation requires the following equipments:

1. DC power source. The output voltage should exceed 6.0V, and output current greater than 3A.
2. Battery simulator or a single-cell battery pack. The battery simulator's output rating should exceed 4.5V/7.0A. When using a real battery pack, please observe all precautions on the battery manufacturer's data sheet first and ensure the charger's setting doesn't exceed the battery's absolute maximum specifications.
3. Oscilloscope. A single voltage probe and a single current probe.
4. Multi-meter.

Charge Function

- 1 Connect the jumper "VCC".
- 2 The jumpers "DCP", "SDP1" and "SDP2" are used for the input DP1/DM1 detection setting. Connect "DCP" and leave "SDP1" and "SDP2" float as default, the DP1/DM1 detection will be set as DCP, the $I_{INLIMIT}$ is set through R_{ILIM} .
Otherwise, only connect "SDP1" and "SDP2", or leave the 3 jumpers float will set the $I_{INLIMIT} = 500mA$.
- 3 Attach the positive and negative ends of the battery to the "BATT" and "GND" terminals, respectively. If it's a battery simulator, please preset the voltage to 3.8V (typical value) first.
- 4 Preset the DC power source to 5.0V. Then attach the DC output port and ground to the "VIN" and "GND" terminals, respectively.
- 5 Turn on the DC power source. The charger will start. Use the oscilloscope to verify that the 3A charge current is being delivered to the battery.

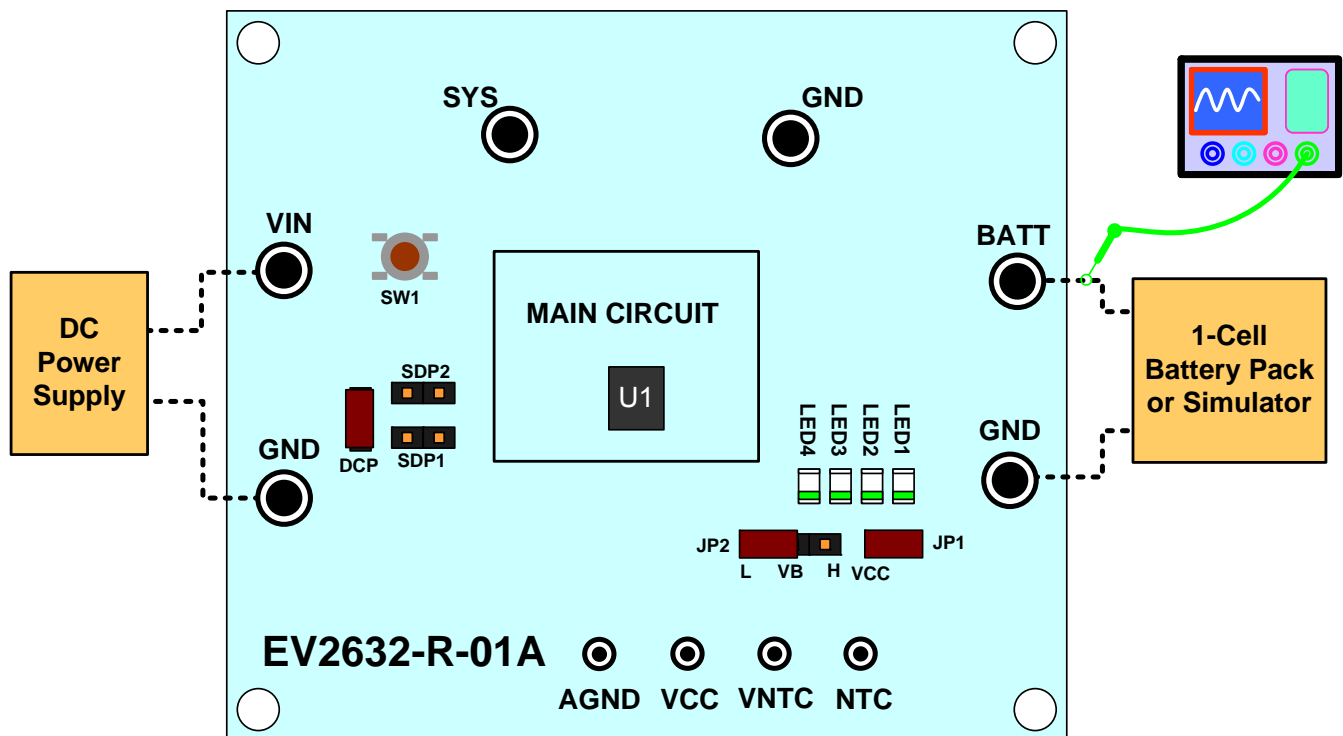

Figure 4: Setup for Charge Mode

Boost Function

- 1 Attach the load to the “SYS” and “GND” terminals respectively.
- 2 Attach the positive and negative ends of the battery to the “BATT” and “GND” terminals respectively. If it’s a battery simulator, please preset the voltage to 3.8V (typical value) firstly.
- 3 Short push the SW1 button, the boost will start to work. Verify the system output current is limited at 3A.

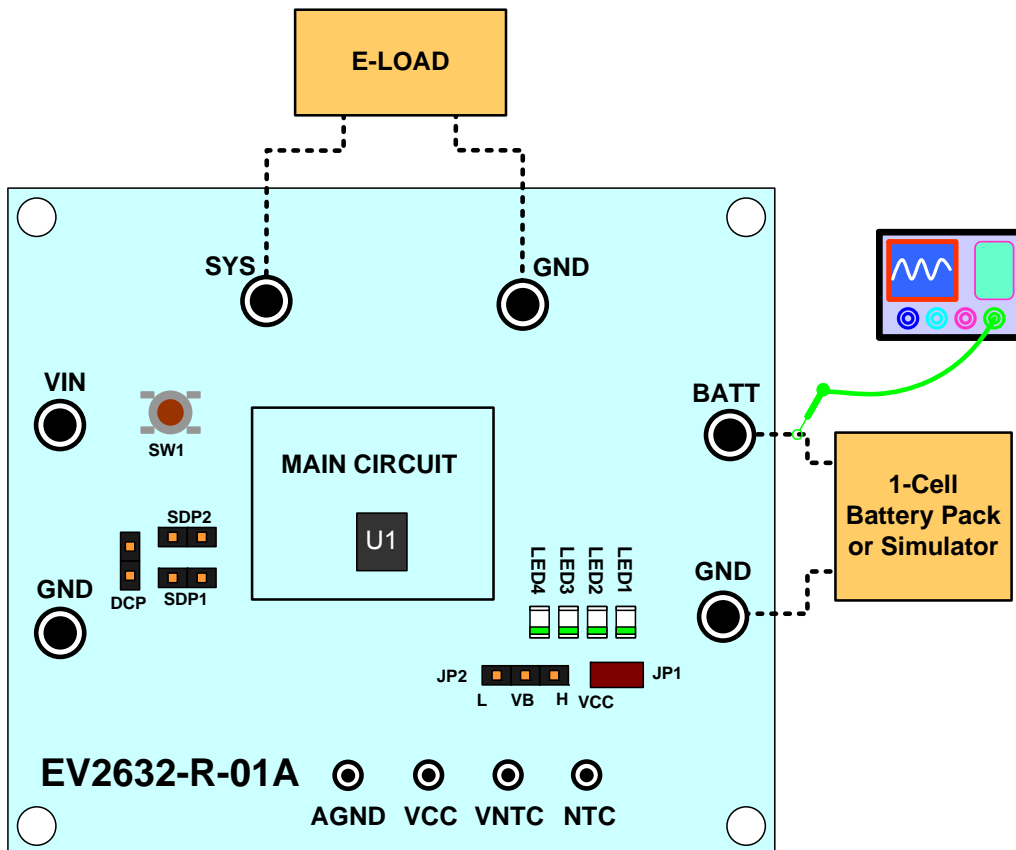

Figure 5: Setup for Boost Mode

NOTICE: The information in this document is subject to change without notice. Users should warrant and guarantee that third party Intellectual Property rights are not infringed upon when integrating MPS products into any application. MPS will not assume any legal responsibility for any said applications.

X-ON Electronics

Largest Supplier of Electrical and Electronic Components

Click to view similar products for [Power Management IC Development Tools](#) *category:*

Click to view products by [Monolithic Power Systems](#) *manufacturer:*

Other Similar products are found below :

[EVAL-ADM1168LQEBZ](#) [EVB-EP5348UI](#) [MIC23451-AAAYFL EV](#) [MIC5281YMME EV](#) [DA9063-EVAL](#) [ADP122-3.3-EVALZ](#) [ADP130-0.8-EVALZ](#) [ADP130-1.2-EVALZ](#) [ADP130-1.5-EVALZ](#) [ADP130-1.8-EVALZ](#) [ADP1712-3.3-EVALZ](#) [ADP1714-3.3-EVALZ](#) [ADP1715-3.3-EVALZ](#) [ADP1716-2.5-EVALZ](#) [ADP1740-1.5-EVALZ](#) [ADP1752-1.5-EVALZ](#) [ADP1828LC-EVALZ](#) [ADP1870-0.3-EVALZ](#) [ADP1871-0.6-EVALZ](#) [ADP1873-0.6-EVALZ](#) [ADP1874-0.3-EVALZ](#) [ADP1882-1.0-EVALZ](#) [ADP199CB-EVALZ](#) [ADP2102-1.25-EVALZ](#) [ADP2102-1.875EVALZ](#) [ADP2102-1.8-EVALZ](#) [ADP2102-2-EVALZ](#) [ADP2102-3-EVALZ](#) [ADP2102-4-EVALZ](#) [ADP2106-1.8-EVALZ](#) [ADP2147CB-110EVALZ](#) [AS3606-DB](#) [BQ24010EVM](#) [BQ24075TEVM](#) [BQ24155EVM](#) [BQ24157EVM-697](#) [BQ24160EVM-742](#) [BQ24296MEVM-655](#) [BQ25010EVM](#) [BQ27411EVM-G1A](#) [BQ3055EVM](#) [NCV891330PD50GEVB](#) [ISLUSBI2CKIT1Z](#) [LM2744EVAL](#) [LM2854EVAL](#) [LM3658SD-AEV/NOPB](#) [LM3658SDEV/NOPB](#) [LM3691TL-1.8EV/NOPB](#) [LM4510SDEV/NOPB](#) [LM5033SD-EVAL](#)