



EV2696A-Q-00B

I²C Controlled Single Cell Switching Charger with Power Path Management and 3A Boost Output

DESCRIPTION

The EV2696A-Q-00B is an evaluation board for the MP2696A, a high-integrated, flexible switch-mode battery charge management and system power path management device.

The MP2696A has three operation modes: charge mode, boost mode and sleep mode.

In charge mode, EV2696A-Q-00B achieves up to 3.6A charge current with a 5V input source.

In boost mode, EV2696A-Q-00B achieves up to 6.5A peak inductor current to deliver a 5V SYS output.

All the parameters and control can be easily accessed via the I2C interface.

ELECTRICAL SPECIFICATION

Parameter	Symbol	Value	Units
Input Voltage	V _{IN}	4-6	V
Input Current Limit	I _{IN}	0.1-3.0 Programmable	A
Charge Voltage Regulation	V _{BATT_REG}	3.6-4.45 Programmable	V
Charge Current	I _{CC}	Up to 3.6 programmable	A
Output Voltage	V _{SYS}	5.05-5.25 Programmable	V
Output Current Limit	I _{OLIM}	2.1-3.6 programmable	A
Output power	P _{OUT}	Up to 18	W

FEATURES

- 4.0V to 6V Operation Voltage Range
- Up to 16V Sustainable Input Voltage
- 500mA to 3.6A Programmable Charge Current
- 3.6V to 4.45V Programmable Charge Regulation Voltage
- 100mA to 3A Programmable Input Current Limit
- Minimum Input Voltage Loop for Maximum Adapter Power Tracking
- Boost-converter with Up to 3.6A Output Current
 - Programmable Output Current Limit Loop
 - Programmable Boost Output Voltage
 - USB Output Cable Compensation
 - Programmable Inductor Peak Current
- Comprehensive Safety Features
 - Fully-customizable JEITA Profile
 - Charge Safety Timer
 - Input Over-voltage Protection
 - Thermal Shutdown
 - SYS Over-current and Short Protection
- Analog Voltage Output IB pin for Battery Current Monitor
- SYS Plug In Detection
- SYS No Load Detection
- SYS DP/DM Interface for BC1.2 and Non-standard Adaptors
- Status and Fault Monitoring

APPLICATIONS

- Sub-Battery Applications
- Power-Bank Application

All MPS parts are lead-free, halogen free, and adhere to the RoHS directive. For MPS green status, please visit MPS website under Quality Assurance.

"MPS" and "The Future of Analog IC Technology" are Registered Trademarks of Monolithic Power Systems, Inc.

EV2696A-Q-00B EVALUATION BOARD

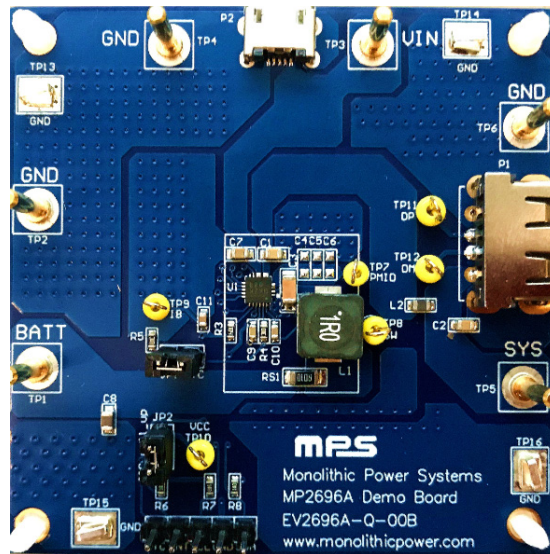

(L x W x H) (6.35cm x 6.35cm x 1.2cm)

Board Number	MPS IC Number
EV2696A-Q-00B	MP2696AGQ-0000

QUICK START GUIDE

1. Please install USB dongle driver on the computer, and connect the dongle to the SCL/GND/SDA connector on the EVM
2. Connect the battery pack to TP1/BATT and TP2/GND connectors, take care of that the battery positive/negative terminal must not be reverse connected.
3. If using a battery emulator, preset the battery emulator to 3.8V/5A and turn off the emulator, connect to TP1/BATT and TP2/GND, then turn on the emulator output.
4. Verify the USB dongle successfully connects the MP2696A to the computer (no warning shows on the top of the GUI).
5. Now the charging and boost parameters can be controlled by the GUI interface.

EVALUATION BOARD SCHEMATIC

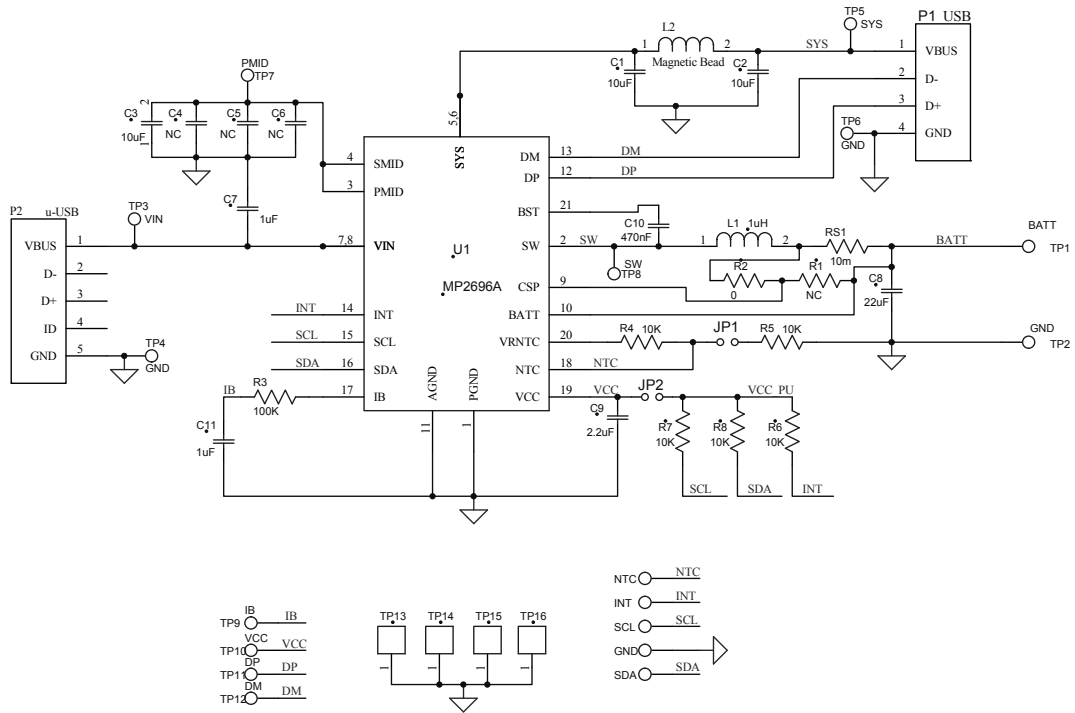

EV2696A-Q-00B BILL OF MATERIALS

Qty	RefDes	Value	Description	Packsge	Manufacturer	Manufacturer_P/N
2	C1, C2	10μF	Capacitor;16V;X5R	0805	muRata	GRM21BR61C106KE15L
1	C3	10μF	Capacitor;16V;X5R	1206	muRata	GRM319R60J106KE19
3	C4,C5, C6	NC	Capacitor;16V;X5R	0805	muRata	GRM21BR61C106KE15L
1	C7	1μF	Capacitor;16V;X5R	0805	muRata	GRM21BR71C105KA01
1	C8	22μF	Capacitor;10V;X7S	0805	TDK	C2012X7S1A226M
1	C9	2.2μF	Ceramic Capacitor;10V;X5R	0603	Murata	GRM188R71A225KE15D
1	C10	470nF	Ceramic Capacitor;25V;X7R; 0603;	0603	TDK	C1608X7R1E474K
1	C11	1μF	Ceramic Capacitor;10V;X7R; 0603	0603	LION	0603B105K100T
6	TP1, TP2, TP3, TP4, TP5, TP6		Connector; 2.0mm	DIP		
6	TP7, TP8 TP9, TP10, TP11, TP12		Test point	DIP		
5	GND, INT, NTC, SCL, SDA		Connector;	DIP		
2	JP1, JP2		Jumper	DIP		
4	TP13, TP14, TP15, TP16		Connector, GND	SMT		
1	L1	1μH	Inductor;1μH;10A	SMD	Würth	74437349010
1	L2	Bead	Magnetic Bead, 3A	805	Würth	742792063
1	P1		USB-A			
1	P2		Micro USB			
1	R1	NC	Film Resistor;			
0	R2	0	Film Resistor;5%;	0603	Yageo	RC0603JR-070RL
1	R3	100kΩ	Film Resistor;5%;	0603	Yageo	RC0603JR-07100KL
2	R4, R5	10kΩ	Film Resistor;1%;	0603	Yageo	RC0603FR-0710KL
1	RS1	10mΩ	Film Resistor;1%;1/4W	1206	Yageo	RL1206FR-070R01L
1	U1		MP2696AGQ-0000	QFN3*3		

CONNECTIONS:

Table 1: Connectors

Connectors	Description
TP1/BATT	Connect to battery pack positive terminal
TP2/GND	Connect to battery pack negative terminal
TP3/VIN	Connect to input source positive terminal
TP4/GND	Connect to input source negative terminal
TP5/SYS	Power bank output positive terminal
TP6/GND	Power bank output negative terminal
P1/ USB-A power output	Power bank output USB receptacle
P2/micro USB power input	Connect to input power adaptor
SCL/SDA/GND/INT	I ² C connector
NTC	Connect to external thermistor

Table 2: Jumpers and Shunts

Jumpers	Description	Default
JP1	Connect on-board NTC divider	Install
JP2	Connect the pull up 10k resistors to VCC, for SCL, SDA and INT.	Install

NOTICE: The information in this document is subject to change without notice. Please contact MPS for current specifications. Users should warrant and guarantee that third party Intellectual Property rights are not infringed upon when integrating MPS products into any application. MPS will not assume any legal responsibility for any said applications.

X-ON Electronics

Largest Supplier of Electrical and Electronic Components

Click to view similar products for [Power Management IC Development Tools](#) *category:*

Click to view products by [Monolithic Power Systems](#) *manufacturer:*

Other Similar products are found below :

[EVAL-ADM1168LQEBZ](#) [EVB-EP5348UI](#) [MIC23451-AAAYFL EV](#) [MIC5281YMME EV](#) [DA9063-EVAL](#) [ADP122-3.3-EVALZ](#) [ADP130-0.8-EVALZ](#) [ADP130-1.2-EVALZ](#) [ADP130-1.5-EVALZ](#) [ADP130-1.8-EVALZ](#) [ADP1712-3.3-EVALZ](#) [ADP1714-3.3-EVALZ](#) [ADP1715-3.3-EVALZ](#) [ADP1716-2.5-EVALZ](#) [ADP1740-1.5-EVALZ](#) [ADP1752-1.5-EVALZ](#) [ADP1828LC-EVALZ](#) [ADP1870-0.3-EVALZ](#) [ADP1871-0.6-EVALZ](#) [ADP1873-0.6-EVALZ](#) [ADP1874-0.3-EVALZ](#) [ADP1882-1.0-EVALZ](#) [ADP199CB-EVALZ](#) [ADP2102-1.25-EVALZ](#) [ADP2102-1.875EVALZ](#) [ADP2102-1.8-EVALZ](#) [ADP2102-2-EVALZ](#) [ADP2102-3-EVALZ](#) [ADP2102-4-EVALZ](#) [ADP2106-1.8-EVALZ](#) [ADP2147CB-110EVALZ](#) [AS3606-DB](#) [BQ24010EVM](#) [BQ24075TEVM](#) [BQ24155EVM](#) [BQ24157EVM-697](#) [BQ24160EVM-742](#) [BQ24296MEVM-655](#) [BQ25010EVM](#) [BQ3055EVM](#) [NCV891330PD50GEVB](#) [ISLUSBI2CKIT1Z](#) [LM2744EVAL](#) [LM2854EVAL](#) [LM3658SD-AEV/NOPB](#) [LM3658SDEV/NOPB](#) [LM3691TL-1.8EV/NOPB](#) [LM4510SDEV/NOPB](#) [LM5033SD-EVAL](#) [LP38512TS-1.8EV](#)