



EV6540HA-U-00A

6A, 50V Three-Phase BLDC Motor Driver Evaluation Board

DESCRIPTION

The EV6540HA-U-00A is an evaluation board for the MP6540HGU-A, a three-phase BLDC motor driver.

It operates from a supply voltage of up to 50V. It integrates three half-bridges consisting of 6 N-channel Power MOSFETs. The rotor position information is provided by the Hall sensors assembled in the motor and the driving control signals are generated by the external controller, such as MCU, FPGA, etc.

ELECTRICAL SPECIFICATION

Parameter	Symbol	Value	Units
Input Voltage	V_{IN}	5.5 – 50	V
Maximum Output Current	$I_{OUT-MAX}$	6	A
VREF Voltage	V_{REF}	3.3 or 5	V

FEATURES

- Wide 5.5V to 50V Input Voltage Range
- Low On-Resistance
- Integrated Bi-directional Current Sense Amplifiers
- Support 100% Duty Cycle Operation
- HS/LS Logic Input
- OCP, OTP
- Fault Indication Output

APPLICATIONS

- Three-Phase Brushless DC Motors and Permanent Magnet Synchronous Motors
- Power Drills
- Impact Drivers

All MPS parts are lead-free, halogen-free, and adhere to the RoHS directive. For MPS green status, please visit the MPS website under Quality Assurance. "MPS", the MPS logo, and "Simple, Easy Solutions" are trademarks of Monolithic Power Systems, Inc. or its subsidiaries.

EV6540HA-U-00A EVALUATION BOARD

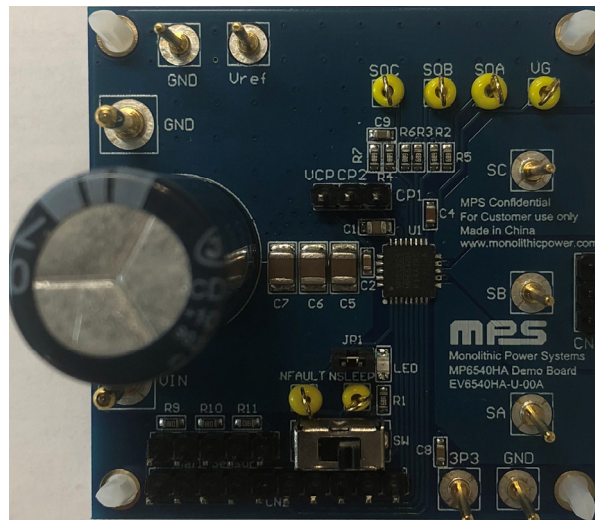

(L x W x H) 2" x 2" x 0.4" (5cm x 5cm x 1cm)

Board Number	MPS IC Number
EV6540HA-U-00A	MP6540HGU-A

EVALUATION BOARD SCHEMATIC

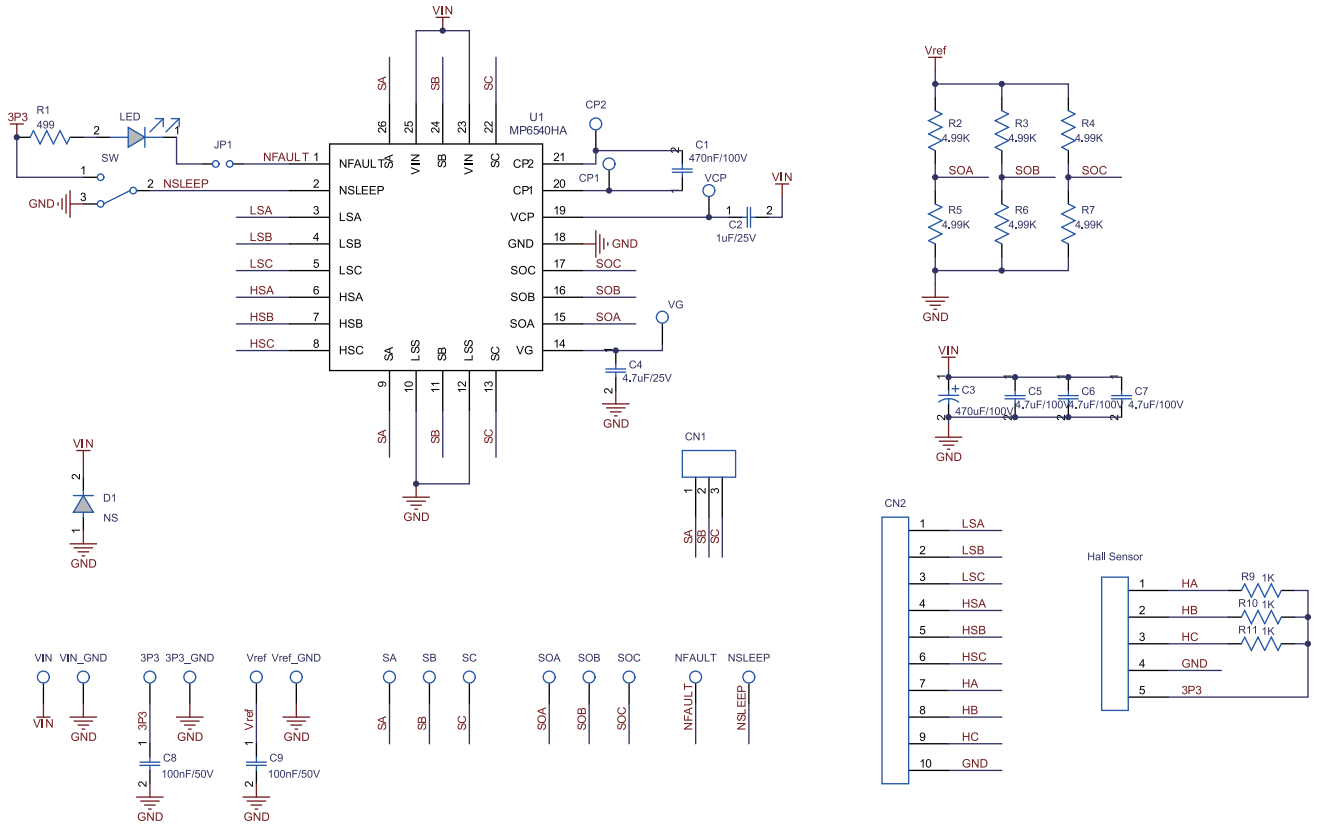

EV6540HA-U-00A BILL OF MATERIALS

Qty	Ref	Value	Description	Package	Manufacturer	Part Number
1	R1	499	Film Resistor; 1%	0603	Yageo	RC0603FR-07499RL
6	R2, R3, R4, R5, R6, R7	4.99k	Film Resistor; 1%	0603	Yageo	RC0603FR-074K99L
3	R9, R10, R11	1k	Film Resistor; 1%	0603	Yageo	RC0603FR-071KL
1	C1	470nF/100V	Ceramic Capacitor; 100V; X7R;	0805	muRata	GRM21BR72A474KA73L
1	C2	1μF/25V	Ceramic Capacitor; 25V; X7R	0603	muRata	GRM188R71E105KA12D
1	C3	470μF/100V	Electrolytic Capacitor; 100V;	DIP	江海	CD263-100V470
1	C4	4.7μF/25V	Ceramic Capacitor; 25V; X6S	0603	muRata	GRM188C81E475KE11D
3	C5, C6, C7	4.7μF/100V	Ceramic Capacitor; 100V; X7S	1210	muRata	GRJ32DC72A475KE11L
2	C8, C9	100nF	Ceramic Capacitor; 50V; X7R	0603	Murata	GCJ188R71H104KA12D
1	LED		LED; 红光;	0805	佰鸿	2012SURC-11
1	U1		Three-phase BLDC Motor Driver	QFN26 (5x5mm)	MPS	MP6540HGU-A
1	D1	NS				
2	CN1, CP1, CP2, VCP		CONN/3PIN/2.54MM			
1	CN2		CONN/10PIN/2.54MM			
1	Hall Sensor		CONN/5PIN/2.54MM			
1	SW		Button	DIP		SS-12D01EG4
1	JP1		CONN/2PIN/2MM			
1	JP1		2MM Short Jumper			
6	NFAULT, NSLEEP, SOA, SOB, SOC, VG		Test Point			
2	VIN, GND		2.0 公针			
7	3P3, 3P3_GND, SA, SB, SC, Vref, Vref_GND		1.0 公针			

PRINTED CIRCUIT BOARD LAYOUT

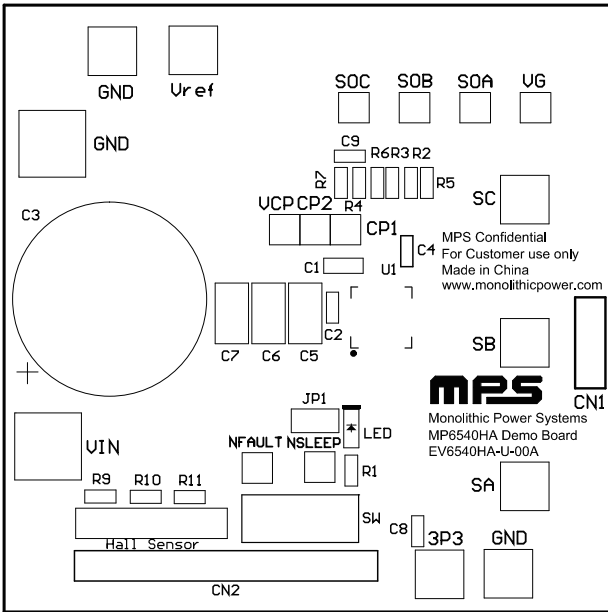

Figure 1: Top Silk Layer

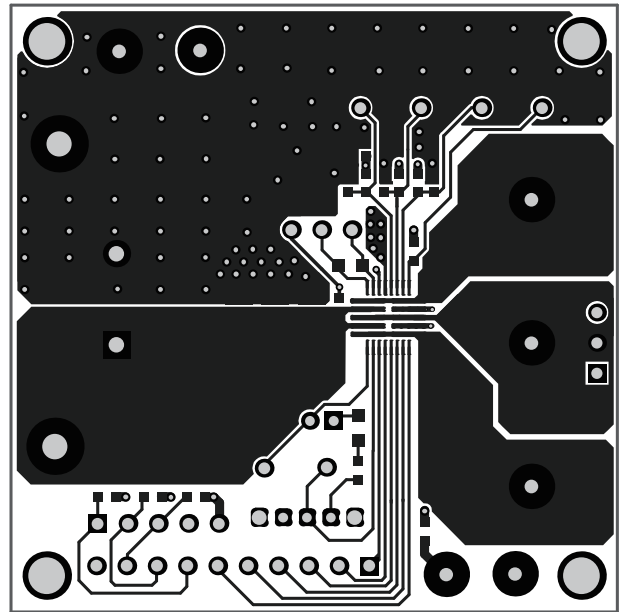

Figure 2: Top Layer

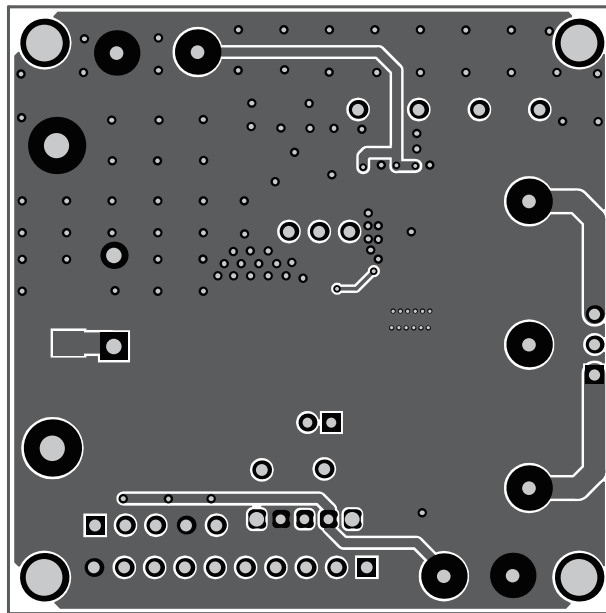

Figure 3: Bottom Layer

QUICK START GUIDE

1. Attach the input voltage ($5.5V \leq V_{IN} \leq 50V$) and input ground to the VIN and GND connectors respectively.
2. Attach a 3.3V or 5V constant voltage to the 3P3 connector and switch the SW1 to the position 1(right side) to enable the chip.
3. Attach a 3.3V or 5V constant voltage to the VREF connector to set the current sense output reference voltage.
4. Attach the hall signals coming from the motor to the Hall Sensor connector.
5. Attach the driving control signals generated by the external controller to the CN2 connector.

NOTICE: The information in this document is subject to change without notice. Users should warrant and guarantee that third party Intellectual Property rights are not infringed upon when integrating MPS products into any application. MPS will not assume any legal responsibility for any said applications.

X-ON Electronics

Largest Supplier of Electrical and Electronic Components

Click to view similar products for [Power Management IC Development Tools](#) *category:*

Click to view products by [Monolithic Power Systems](#) *manufacturer:*

Other Similar products are found below :

[EVB-EP5348UI](#) [BQ25010EVM](#) [ISLUSBI2CKIT1Z](#) [ISL8002AEVAL1Z](#) [ISL91108IIA-EVZ](#) [ISL28022EVKIT1Z](#) [STEVAL-ISA008V1](#)
[DRI0043](#) [NCP10671B05GEVB](#) [EVB-EN6337QA](#) [SAMPLEBOXILD8150TOBO1](#) [AP63300WU-EVM](#) [AP61100Z6-EVM](#)
[KITA2GTC387MOTORCTRTOBO1](#) [AEK-MOT-TK200G1](#) [EVLONE65W](#) [STEVAL-ILH006V1](#) [STEVAL-IPE008V2](#) [STEVAL-IPP001V2](#)
[STEVAL-ISA013V1](#) [STEVAL-ISA067V1](#) [STEVAL-ISQ002V1](#) [TPS2306EVM-001](#) [TPS2330EVM-185](#) [TPS40001EVM-001](#) [SECO-](#)
[HVDCDC1362-15W-GEVB](#) [BTS7030-2EPA](#) [LTC3308AIV#WTRPBF](#) [TLT807B0EPV](#) [BTS71033-6ESA](#) [EV13N91A](#) [EV55W64A](#)
[Si8285_86v2-KIT](#) [NCP-NCV51752D2PAK3LGEVB](#) [ISL81807EVAL1Z](#) [EVALM7HVIGBTPFCINV4TOBO1](#) [903-0300-000](#) [902-0173-000](#)
[903-0301-000](#) [ROA1286023/1](#) [REFSHA35IMD111TSYSTOBO1](#) [150037482](#) [TDINV3000W50B-KIT](#) [NCP1681CCM1KWGEVB](#) [I7C08A-](#)
[CC3-EVK-P2](#) [I7C12A-CC3-EVK-P2](#) [i7C20A-CC3-EVK-P2](#) [APEK89303KET-01-T](#) [NCP1681MM500WGEVB](#) [SI83401BAA-KIT](#)