

DESCRIPTION

The EV6550-G-00A is an evaluation board for the MP6550, an H-bridge motor driver. It operates from a supply voltage of up to 22V and can deliver motor current up to 2A.

The MP6550 has a PWM interface, which is compatible with industry-standard devices. Very low standby circuit current can be achieved when disabled the device. The MP6550 is available in a QFN2X2-12 package, it is typically used to drive a DC brushed motor.

ELECTRICAL SPECIFICATION

Parameter	Symbol	Value	Units
Input Voltage	V _{IN}	1.8-22	V
Output Current	I _{OUT}	2	A

FEATURES

- Wide 1.8V to 22V Input Voltage Range
- Up to 2A Continuous Driver Current
- Built-in 3.3V Reference Output PWM Input Interface which is Compatible Industry-standard Devices
- Low Standby Circuit Current
- Thermal Shutdown Protection
- Short Circuit Protection
- Available in a QFN2X2-12 Package

APPLICATIONS

- Solenoid Drivers
- DC Brush Motor Drive

All MPS parts are lead-free, halogen-free, and adhere to the RoHS directive. For MPS green status, please visit the MPS website under Quality Assurance. "MPS" and "The Future of Analog IC Technology" are registered trademarks of Monolithic Power Systems, Inc.

EV6550-G-00A EVALUATION BOARD



(L x W x H) 6.35cm x 6.35cm x 1cm

Board Number	MPS IC Number
EV6550-G-00A	MP6550GG

EVALUATION BOARD SCHEMATIC

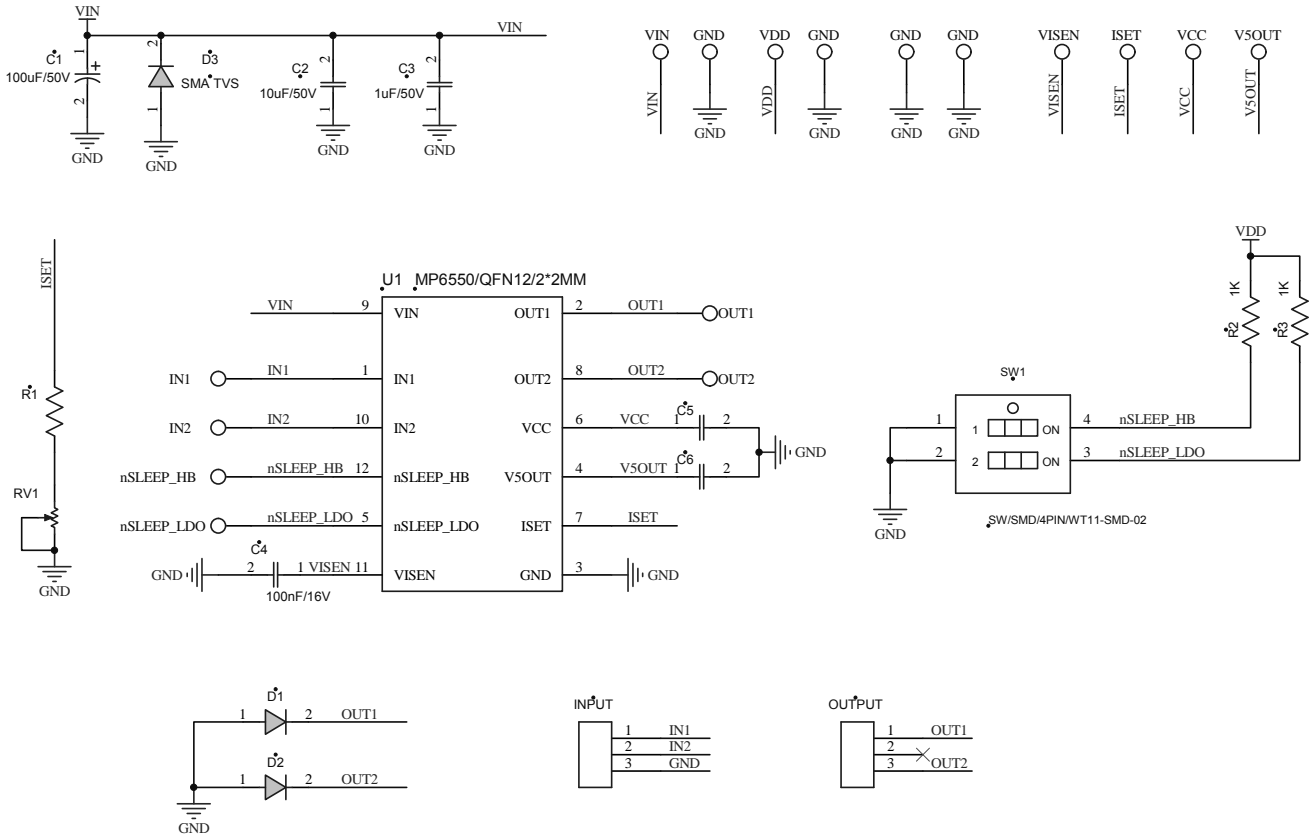

EV6550-G-00A BILL OF MATERIALS

Qty	RefDes	Value	Description	Package	Manufacturer	Manufacturer P/N
1	C1	100 μ F/ 50V	Electrolytic Capacitor;50V;Electroly tic	DIP	Rubycon	50YXF100MEFC
2	C2	10 μ F/ 50V	Ceramic Capacitor;50V;X7R	1210	muRata	GRM32ER71H106KA12L
1	C3	100nF/ 50V	Ceramic Capacitor;50V;X7R	0603	muRata	GRM188R71H104KA93D
1	C4	100pF/ 50V	Ceramic Capacitor;50V;X7R	0603	muRata	GRM1885C1H101JA01D
2	C5, C6	1 μ F/ 16V	Ceramic Capacitor;16V;X7R;	0603	muRata	GRM188R71C105KA12D
1	R1	1k	Film Resistor;1%	0603	Yageo	RC0603FR-071KL
2	R2, R3	4.7k	Film Resistor;1%	0603	Yageo	RC0603FR-074K7L
1	RV1	10k	Potentiometer	DIP		3266W-1-103F
3	D1, D2, D3	NS				
1	SW1		Dual Switch			WT11-SMD-02
8	VCC, NSLEEP_ LDO, NSLEEP_ HB, VISEN, V5OUT, IN1, IN2, ISET		Test Point			
2	OUTPUT, INPUT		2.54MM Connector			
6	OUT1, OUT2, VDD, GND1, GND2, GND3		1MM 公针			
2	VIN, GND		2MM 公针			
1	U1		H-bridge motor driver	QFN2X2 -12	MPS	MP6550GG

PRINTED CIRCUIT BOARD LAYOUT

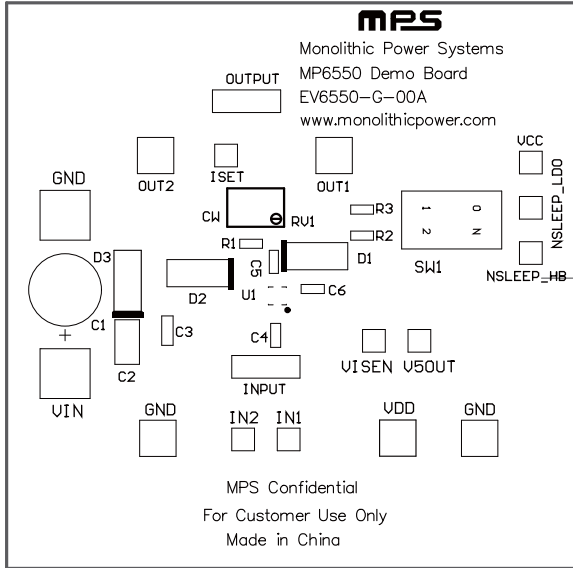

Figure 1: Top Silkscreen Layer

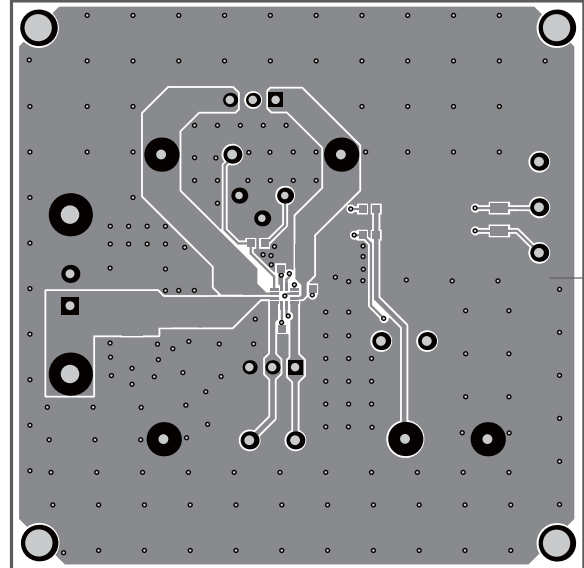

Figure 2: Top Layer

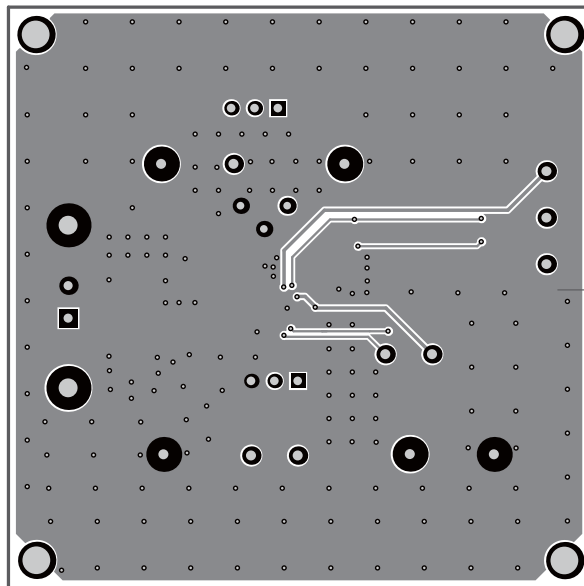

Figure 3: Bottom Layer

QUICK START GUIDE

1. Attach the input signal (PWM or DC) to the INPUT connector.
2. Attach the VDD supply voltage (3.3V) and ground to the VDD and GND terminals respectively.
3. Attach the VIN supply voltage ($1.8V \leq V_{IN} \leq 22V$) and ground to the VIN and GND terminals respectively.
4. Switch SW1 to enable or disable H-bridge and LDO output.
5. Rotate RV1 to adjust the output current limit.

NOTICE: The information in this document is subject to change without notice. Users should warrant and guarantee that third party Intellectual Property rights are not infringed upon when integrating MPS products into any application. MPS will not assume any legal responsibility for any said applications.

X-ON Electronics

Largest Supplier of Electrical and Electronic Components

Click to view similar products for [Power Management IC Development Tools](#) *category:*

Click to view products by [Monolithic Power Systems](#) *manufacturer:*

Other Similar products are found below :

[EVAL-ADM1168LQEBZ](#) [EVB-EP5348UI](#) [MIC23451-AAAYFL EV](#) [MIC5281YMME EV](#) [DA9063-EVAL](#) [ADP122-3.3-EVALZ](#) [ADP130-0.8-EVALZ](#) [ADP130-1.2-EVALZ](#) [ADP130-1.5-EVALZ](#) [ADP130-1.8-EVALZ](#) [ADP1712-3.3-EVALZ](#) [ADP1714-3.3-EVALZ](#) [ADP1715-3.3-EVALZ](#) [ADP1716-2.5-EVALZ](#) [ADP1740-1.5-EVALZ](#) [ADP1752-1.5-EVALZ](#) [ADP1828LC-EVALZ](#) [ADP1870-0.3-EVALZ](#) [ADP1871-0.6-EVALZ](#) [ADP1873-0.6-EVALZ](#) [ADP1874-0.3-EVALZ](#) [ADP1882-1.0-EVALZ](#) [ADP199CB-EVALZ](#) [ADP2102-1.25-EVALZ](#) [ADP2102-1.875EVALZ](#) [ADP2102-1.8-EVALZ](#) [ADP2102-2-EVALZ](#) [ADP2102-3-EVALZ](#) [ADP2102-4-EVALZ](#) [ADP2106-1.8-EVALZ](#) [ADP2147CB-110EVALZ](#) [AS3606-DB](#) [BQ24010EVM](#) [BQ24075TEVM](#) [BQ24155EVM](#) [BQ24157EVM-697](#) [BQ24160EVM-742](#) [BQ24296MEVM-655](#) [BQ25010EVM](#) [BQ27411EVM-G1A](#) [BQ3055EVM](#) [NCV891330PD50GEVB](#) [ISLUSBI2CKIT1Z](#) [LM2744EVAL](#) [LM2854EVAL](#) [LM3658SD-AEV/NOPB](#) [LM3658SDEV/NOPB](#) [LM3691TL-1.8EV/NOPB](#) [LM4510SDEV/NOPB](#) [LM5033SD-EVAL](#)