



EV6606-F-00A

8-Channel Low-Side Driver with Serial Interface Evaluation Board

DESCRIPTION

The EV6606-F-00A evaluation board is designed to demonstrate the capabilities of the MP6606, an 8-channel low-side (LS) driver with a serial interface. It integrates low-side MOSFETs (LS-FETs) and high-side (HS) clamp diodes to drive inductive loads.

The MP6606 operates from a supply voltage up to 60V, and can deliver an output current (I_{OUT}) up to 750mA. The MP6606 supports a 3.3V and 5V logic supply. Internal safety features include over-current protection (OCP), under-voltage lockout (UVLO), and over-temperature (OT) shutdown.

The MP6606 has a LATCH pin. A rising edge on the LATCH pin latches the data from the temporary shift register into the output stage. LATCH provides the synchronizing signal in a multiple-device system.

The MP6606 is typically used for unipolar stepper motors and solenoid drivers. The MP6606 is available in a thermally enhanced TSSOP-20EP package with an exposed thermal pad.

PERFORMANCE SUMMARY

Specifications are at $T_A = 25^\circ\text{C}$, unless otherwise noted.

Parameters	Conditions	Value
Supply voltage range (V_{IN})	24V TVS diode connected between V_{IN} and VCLAMP	4.5V to 30V
	VCLAMP connected to V_{IN}	4.5V to 60V
High-side (HS) clamp voltage (V_{CLAMP})		$\leq 60\text{V}$
Maximum low-side (LS) output current (I_{OUT_LS})	For low-side MOSFETs (LS-FETs)	750mA
Maximum HS output current (I_{OUT_HS})	For HS diodes	750mA at duty cycle < 20%

EV6606-F-00A EVALUATION BOARD

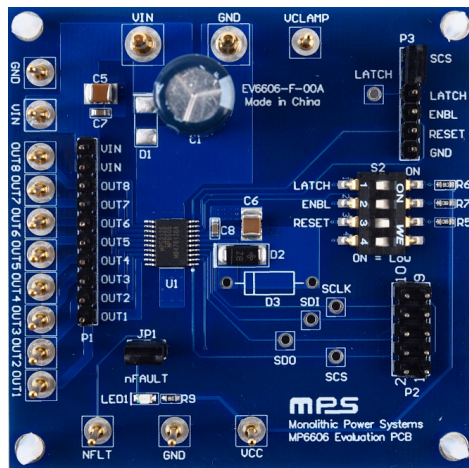

LxWxH (6.35cmx6.35cmx2.5cm)

Board Number	MPS IC Number
EV6606-F-00A	MP6606GF

QUICK START GUIDE

1. Preset the logic power supply voltage (typically 3.3V or 5V).
2. To preset the input power supply voltage, follow the steps below:
 - a. Connect the 24V TVS diode between the VIN and VCLAMP pins (where V_{IN} is between 4.5V and 30V).
 - b. Connect VCLAMP to VIN (where V_{IN} is between 4.5V and 60V).
3. Connect the SPI communication interface to P2.
4. Connect the loads to the OUTx terminals.
5. Connect the logic power supply terminals to:
 - a. Positive (+): VCC
 - b. Negative (-): GND
6. Connect the input power supply terminals to:
 - a. Positive (+): VIN
 - b. Negative (-): GND
7. Connect the LATCH pin to SCS via a jumper on P3, or control LATCH via S2's dial switch.
8. LED1 indicates fault events including over-current protection (OCP), under-voltage lockout (UVLO), and over-temperature (OT) shutdown.

Figure 1 shows the measurement equipment set-up.

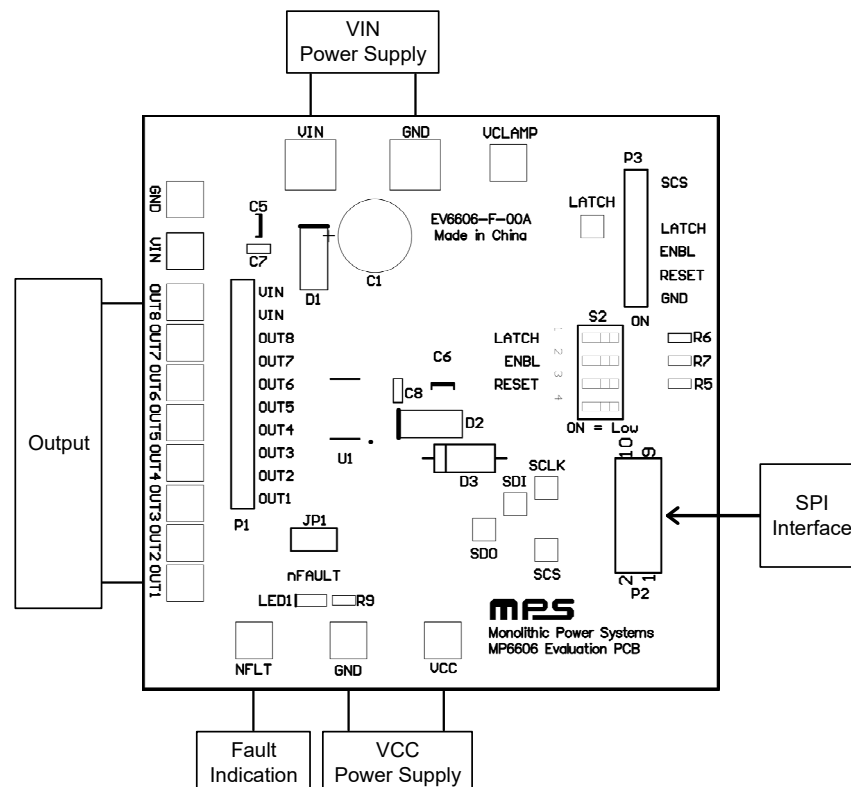

Figure 1: Measurement Equipment Test Set-Up

GUI OPERATION

To configure the device using the graphic user interface (GUI), refer to Figure 2 and follow the steps below:

1. Select the SPI clock frequency (the default is 100kHz).
2. Input the hexadecimal data to Send Buf (e.g. “FF” turns on all the LS-FETs).
3. Set the delay time (denoted as “Delay Time” in Figure 2) under the Send Buf section. The delay time is set between two bytes. Typically, its default value is used.
4. Click “Send” to send the typed data once. Click “Loop Send” to send the data repeatedly with a fixed frequency.
5. The serial data output can be read in Receive Buf. Note that the data cannot be displayed in loop send mode.

Clock Frequency:

Send Buf (Hex)

Example: 'FF'

Out8 Out7 Out6 Out5 Out4 Out3 Out2 Out1

Send Binary Data

0

Delay Time(ms):

Send
Loop Send
Clear

Receive Buf (Hex)

Receive Hex Data

Out8 Out7 Out6 Out5 Out4 Out3 Out2 Out1

Receive Binary Data

0

Figure 2: GUI Operation Configuration

EVALUATION BOARD SCHEMATIC

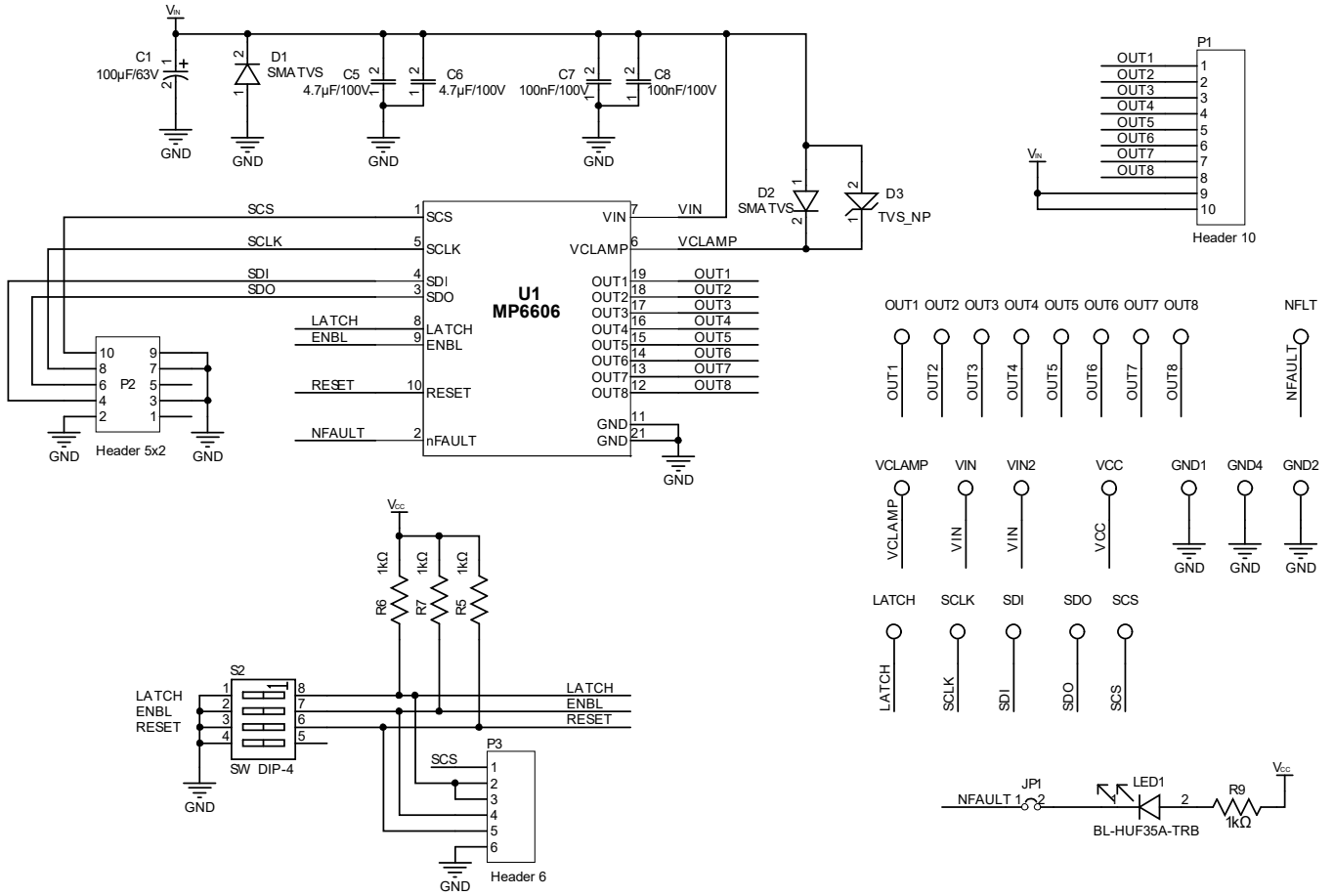

Figure 3: Evaluation Board Schematic

EV6606-F-00A BILL OF MATERIALS

Qty	Ref	Value	Description	Package	Manufacturer	Manufacturer PN
1	C1	100 μ F	Electrolytic capacitor, 100V	DIP	Jianghai	CD263-100V100
2	C5, C6	4.7 μ F	Ceramic capacitor, 100V, X8L	1210	Murata	GCM32DL8EL475KE07L
2	C7, C8	100nF	Ceramic capacitor, 100V, X7R	0603	Murata	GRM188R72A104KA35D
4	R5, R6, R7, R9	1k Ω	Film resistor, 1%	0603	Yageo	RC0603FR-071KL
2	D1, D3	NS				
1	D2	24V	TVS diode	DO-214C-2	Vishay	SMAJ24A
1	S2	4-bit	Dial switch	SMD	Würth	418121270804
1	LED1	20mA	Red LED	0805	Baihong	BL-HUE35A-AV-TRB
3	JP1, P1, P3	2.54mm	Single-line needle	SIP	Custom	
1	P2	2.54mm	Dual-line needle	DIP	Custom	
2	VIN, GND1	2mm	Needle	SIP	Custom	
14	VCLAMP, GND2, VIN2, OUT1, OUT2, OUT3, OUT4, OUT5, OUT6, OUT7, OUT8, NFLT, GND4, VCC	1mm	Needle	SIP	Custom	
1	U1	MP6606	8-channel low-side driver with serial interface	TSSOP-20EP	MPS	MP6606GF

EV6606 TEST RESULTS

$V_{IN} = 12V$, $V_{CLAMP} = 24V$ TVS to V_{IN} , $T_A = 25^\circ C$, resistor + inductor load: $R = 33\Omega$, $L = 1.5mH$ per channel, unless otherwise noted.

Normal Operation

$f_{sw} = 1kHz$

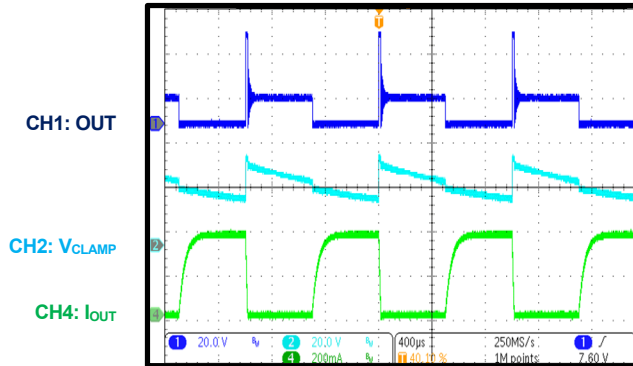

Start-Up through VIN

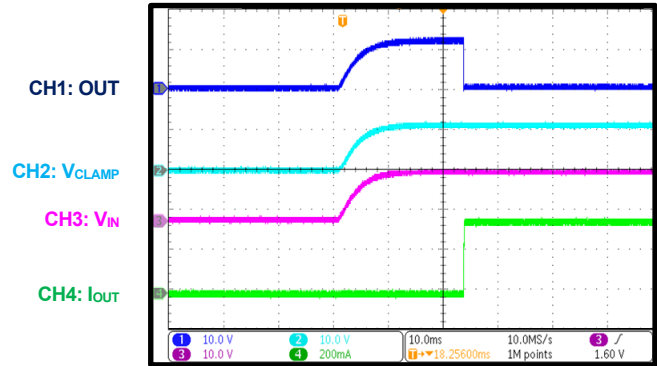

Shutdown through VIN

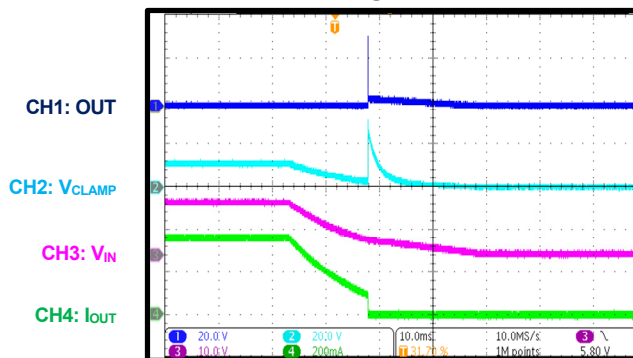

SCP

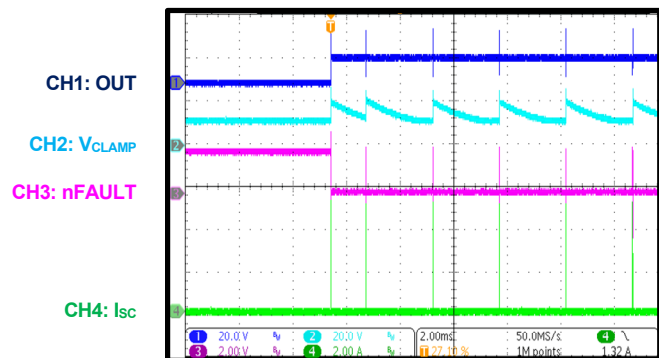

Chip Enabled

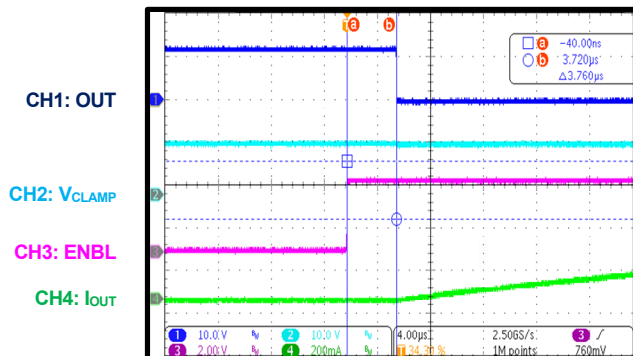

Chip Disabled

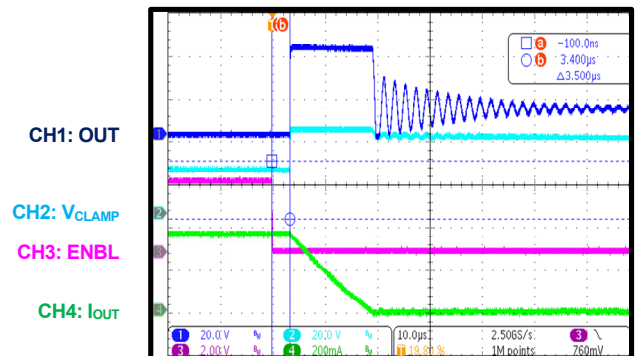

PCB LAYOUT

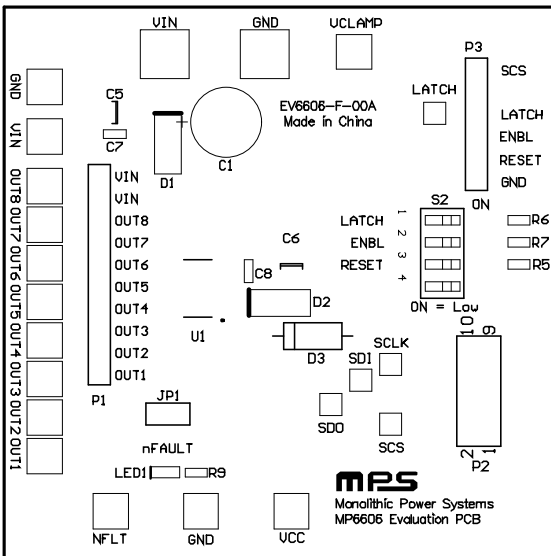

Figure 4: Top Silk

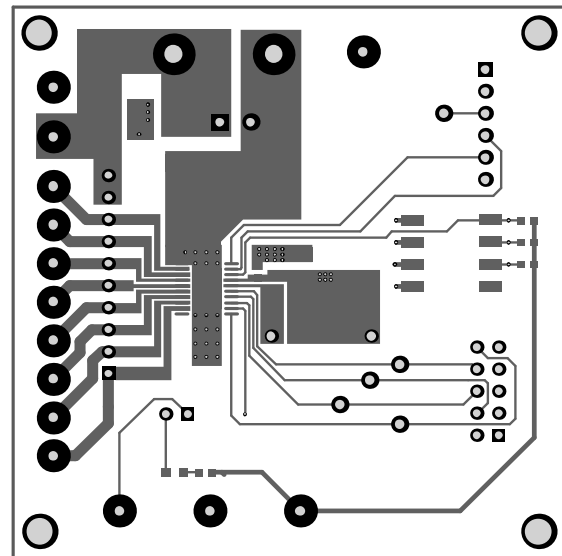

Figure 5: Top Layer

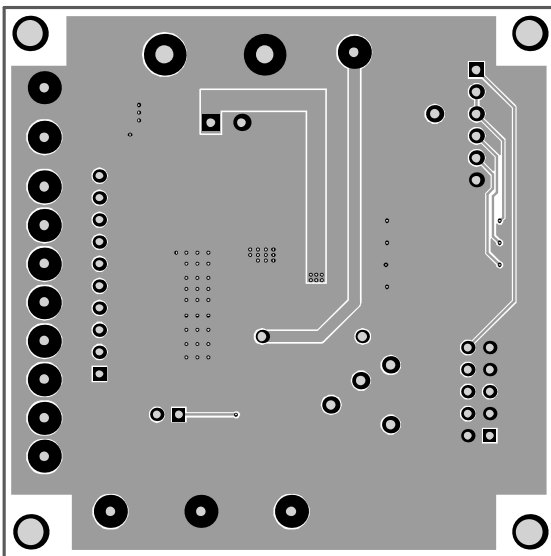

Figure 6: Bottom Layer



REVISION HISTORY

Revision #	Revision Date	Description	Pages Updated
1.0	7/5/2022	Initial Release	-

Notice: The information in this document is subject to change without notice. Please contact MPS for current specifications. Users should warrant and guarantee that third-party Intellectual Property rights are not infringed upon when integrating MPS products into any application. MPS will not assume any legal responsibility for any said applications.

X-ON Electronics

Largest Supplier of Electrical and Electronic Components

Click to view similar products for [Power Management IC Development Tools](#) *category:*

Click to view products by [Monolithic Power Systems](#) *manufacturer:*

Other Similar products are found below :

[EVB-EP5348UI](#) [DA9063-EVAL](#) [BQ24155EVM](#) [BQ25010EVM](#) [REG710EVM-5](#) [TPS54980EVM-022](#) [TPS65010EVM-230](#) [BQ24120EVM-001](#) [BQ24212EVM-678](#) [BQ3050EVM-001](#) [ISL9520EVAL1Z](#) [UCC3809EVM](#) [LM3691TL-1.2EV/NOPB](#) [SOT23-3EV-VREG](#) [SOT89-3EV-VREG](#) [TPS2458EVM](#) [TPS54229EEVM-056](#) [TPS54329EEVM-056](#) [MAX8556EVKIT](#) [MAX20012EVKIT#](#) [MAX15005AEVKIT+](#) [S6SBP203A8FVA1001](#) [TPS652510EVM](#) [STEVAL-ISA047V1](#) [ISL8502AEVAL1Z](#) [ISL8009AEVAL1Z](#) [TPS76901EVM-127](#) [FRDM-HB2001-EVM](#) [BM6208FS-EVK-001](#) [LM5115EVAL](#) [LP5900TL-2.5EV](#) [DRI0043](#) [7E.12.8.230.0002](#) [KITPF8100FRDMEVM](#) [NCP10671B05GEVB](#) [MAX20073EVKIT#](#) [EVB-EN6337QA](#) [AP3125AEV1](#) [NIV6350MT2GEVB](#) [XMCA1](#) [RD33771-48VEVM](#) [EVKT-MPM3695-10-A](#) [DEMO200W12VDCLLC](#) [SAMPLEBOXILD8150TOBO1](#) [MAX18066EVKIT#](#) [AP61100Z6-EVM](#) [AP62300WU-EVM](#) [KIT8020-CRD-8FF1217P-1](#) [KITPF8121FRDMEVM](#) [EV2174C-G-00A](#)