

### DESCRIPTION

The LN60A01 is a three channel, 600V N-Channel, enhancement mode power FET manufactured in MPS's proprietary, high-voltage DMOS technology.

This advanced technology has been especially tailored to minimize the on-state resistance, provide superior switching performance, and withstand high energy pulses in the avalanche and commutation modes. This device is well suited for high efficiency switched mode power supplies and active power factor correction.

The LN60A01 is available in PDIP8 and SOIC8 package.

### FEATURES

- 600V Breakdown Voltage
- Three N-Channel MOSFETs
- One Gate control to All Three FETs
- $R_{ds(on)}=200\Omega$  at  $V_{gs}=10V$
- Switching Current  $>0.1A$
- Fast Switching

### APPLICATIONS

- High Efficiency AC/DC Adaptor
- Offline Switching Power Supply
- Active Power Factor Correction

"MPS" and "The Future of Analog IC Technology" are Registered Trademarks of Monolithic Power Systems, Inc.

### TYPICAL APPLICATION

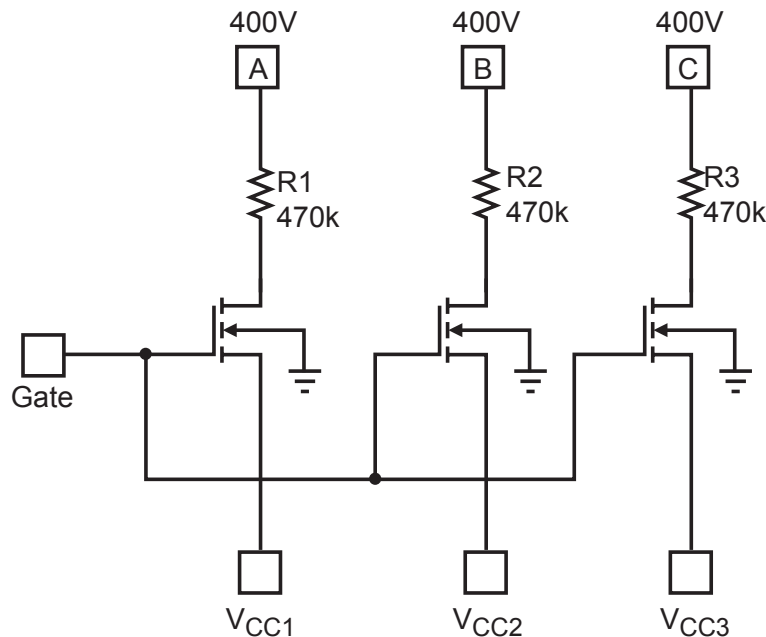

### ORDERING INFORMATION

Part Number*	Package	Top Marking	Free Air Temperature (T <sub>A</sub> )
LN60A01EP	PDIP-8	LN60A01E	-20°C to 85°C
Part Number**	Package	Top Marking	Free Air Temperature (T <sub>A</sub> )
LN60A01ES	SOIC-8	LN60A01E	-20°C to 85°C

\*For RoHS compliant packaging, add suffix –LF (e.g. LN60A01EP–LF)

\*\* For Tape & Reel, add suffix –Z (e.g. LN60A01ES–Z).

For RoHS compliant packaging, add suffix –LF (e.g. LN60A01ES–LF–Z)

### PACKAGE REFERENCE

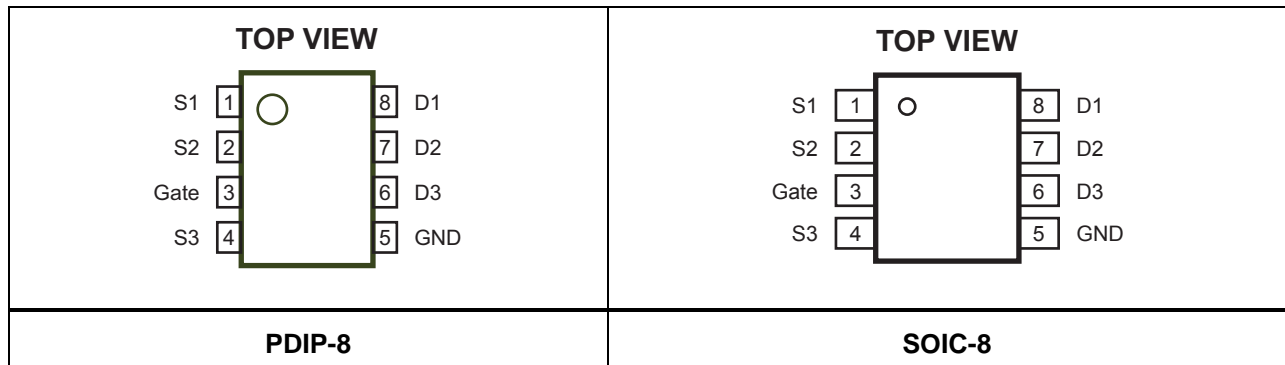

#### ABSOLUTE MAXIMUM RATINGS <sup>(1)</sup>

Drain-Source Voltage V <sub>DS</sub> .....	600V
Gate-Source Voltage V <sub>GS</sub> .....	15V
Continuous Drain Current <sup>(1)</sup> I <sub>D</sub> .....	0.08A
Pulsed Drain Current <sup>(2)</sup> I <sub>DM</sub> .....	0.4A
Power Dissipation <sup>(1) (2)</sup> P <sub>D</sub> .....	1.3W
Storage Temperature.....	-55°C to +150°C

#### Recommended Operating Conditions

Operating Junct. Temp (T<sub>J</sub>)..... -20°C to +125°C

#### Thermal Resistance <sup>(3)</sup>

	$\theta_{JA}$	$\theta_{JC}$
SOIC8 .....	90 ... 45...	°C/W
PDIP8 .....	105... . 45. .	°C/W

#### Notes:

- 1) Surface Mounted on 1"×1" FR4 Board..
- 2) Pulse width limited by maximum junction temperature.
- 3) Measured on JESD51-7, 4-layer PCB

## ELECTRICAL CHARACTERISTICS

T<sub>A</sub> = +25°C, unless otherwise noted.

Parameters	Symbol	Condition	Min	Typ	Max	Units
<b>Static Parameter</b>						
Drain-Source Breakdown Voltage	V <sub>(BR)DSS</sub>	V <sub>GS</sub> =0V, I <sub>D</sub> =30uA		600		V
Gate Threshold Voltage	V <sub>GS(th)</sub>	V <sub>DS</sub> =V <sub>GS</sub> , I <sub>D</sub> =250uA	0.8	1.0	1.2	V
Zero Gate Voltage Drain Current	I <sub>DSS</sub>	V <sub>DS</sub> =400V, V <sub>GS</sub> =0V		15		μA
Drain-Source On-Resistance	r <sub>DS(on)</sub>	V <sub>GS</sub> =10V, I <sub>D</sub> =10mA		190		Ω
		V <sub>GS</sub> =5V, I <sub>D</sub> =10mA		200		
<b>Switching Parameter</b>						
Turn-On Delay Time	t <sub>(on)</sub>	V <sub>DS</sub> =350V, I <sub>DS</sub> =10mA		50		ns
Turn-Off Delay Time	t <sub>(off)</sub>			3000		

## PIN FUNCTIONS

Pin Number	Pin Name	Description
1	S1	Source 1
2	S2	Source 2
3	Gate	Gate
4	S3	Source 3
5	GND	Ground
6	D3	Drain 3
7	D2	Drain 2
8	D1	Drain 1

DEVICE CIRCUIT

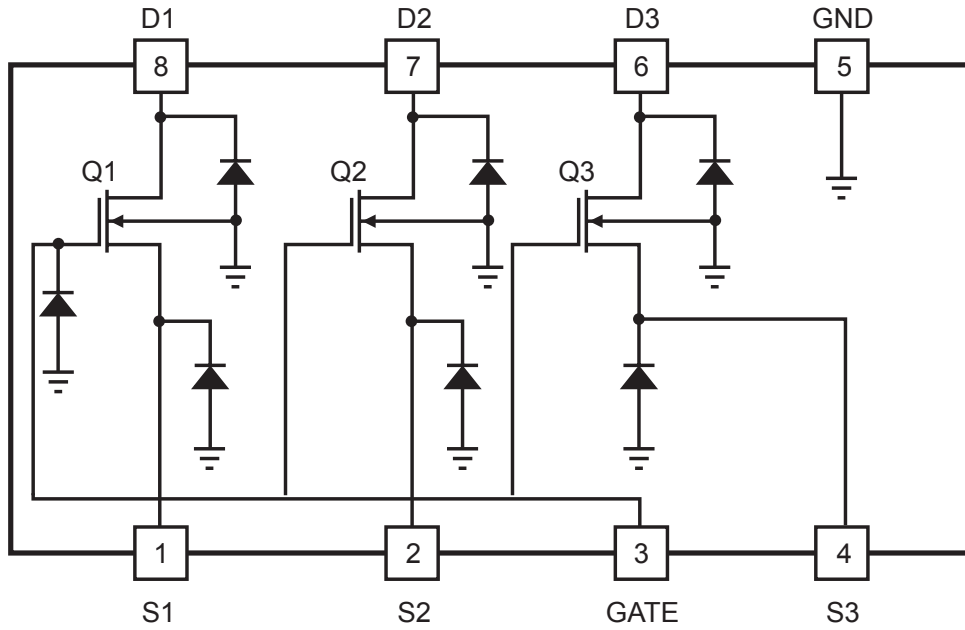

### TYPICAL PERFORMANCE CHARACTERISTICS

T<sub>A</sub> = 25° C, unless otherwise noted.

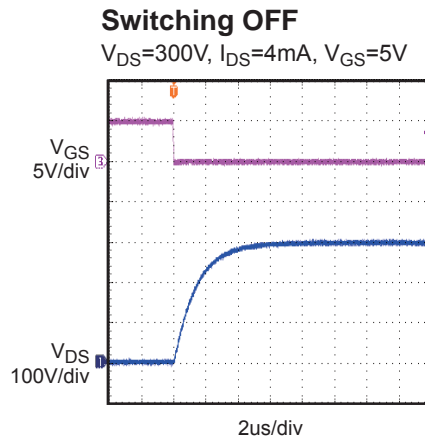
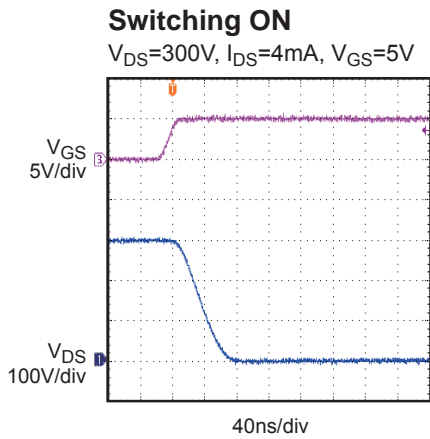
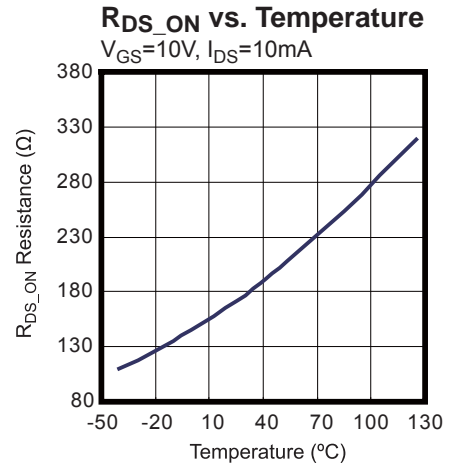
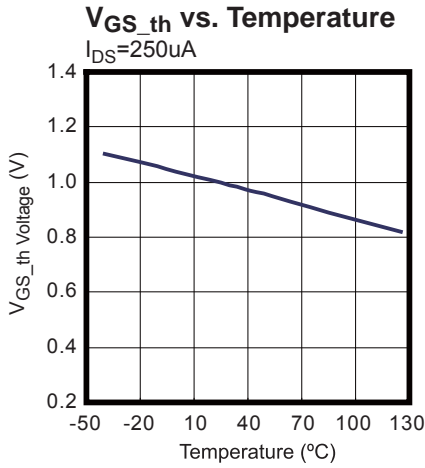
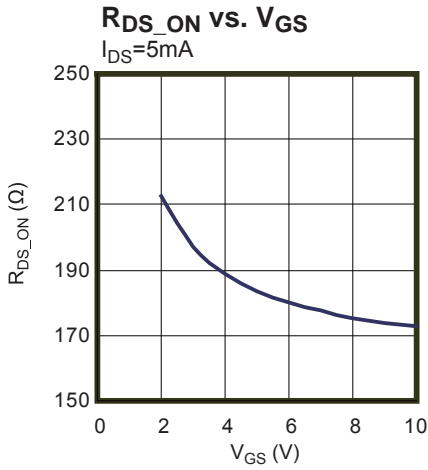

PACKAGE INFORMATION

PDIP-8

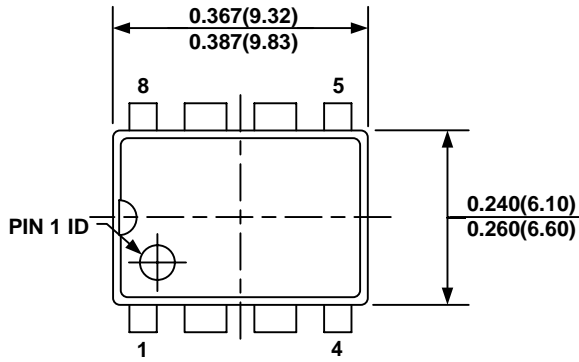

TOP VIEW

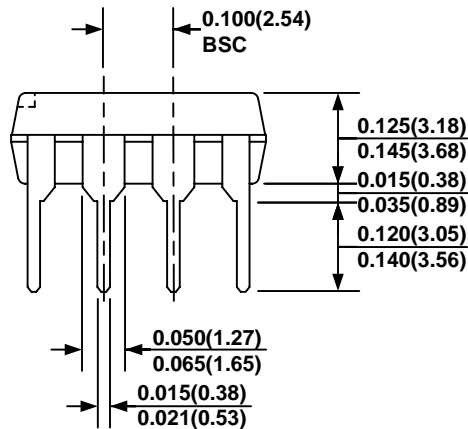

FRONT VIEW

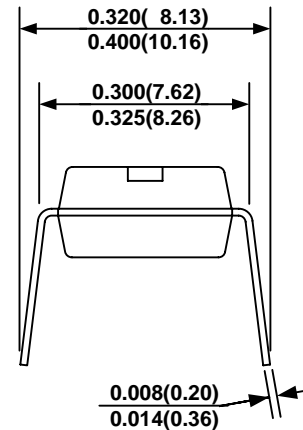

SIDE VIEW

**NOTE:**

- 1) CONTROL DIMENSION IS IN INCHES. DIMENSION IN BRACKET IS IN MILLIMETERS.
- 2) PACKAGE LENGTH AND WIDTH DO NOT INCLUDE MOLD FLASH, OR PROTRUSIONS.
- 3) DRAWING CONFORMS TO JEDEC MS-001, VARIATION BA.
- 4) DRAWING IS NOT TO SCALE.

## PACKAGE INFORMATION

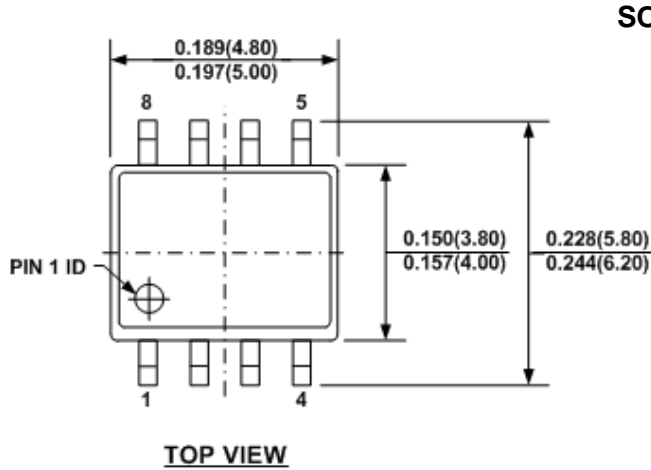

### SOIC8

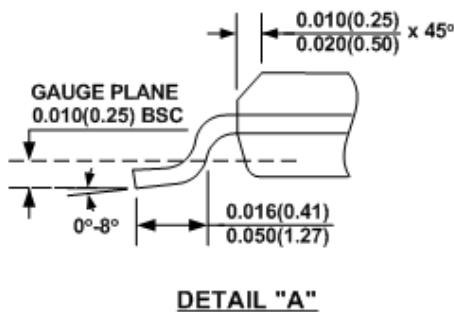
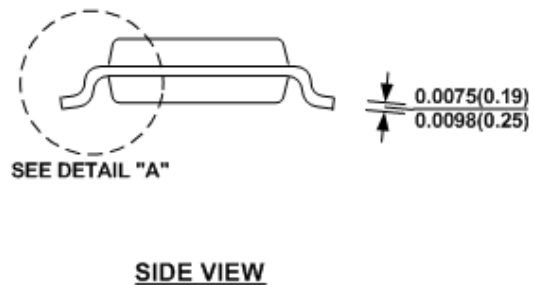
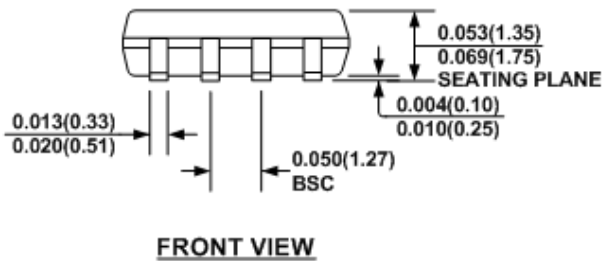
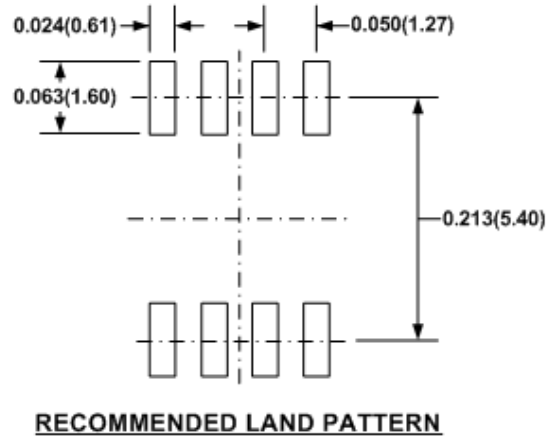

### NOTE:

- 1) CONTROL DIMENSION IS IN INCHES. DIMENSION IN BRACKET IS IN MILLIMETERS.
- 2) PACKAGE LENGTH DOES NOT INCLUDE MOLD FLASH, PROTRUSIONS OR GATE BURRS.
- 3) PACKAGE WIDTH DOES NOT INCLUDE INTERLEAD FLASH OR PROTRUSIONS.
- 4) LEAD COPLANARITY (BOTTOM OF LEADS AFTER FORMING) SHALL BE 0.004" INCHES MAX.
- 5) DRAWING CONFORMS TO JEDEC MS-012, VARIATION AA.
- 6) DRAWING IS NOT TO SCALE.

**NOTICE:** The information in this document is subject to change without notice. Please contact MPS for current specifications. Users should warrant and guarantee that third party Intellectual Property rights are not infringed upon when integrating MPS products into any application. MPS will not assume any legal responsibility for any said applications.

## X-ON Electronics

Largest Supplier of Electrical and Electronic Components

*Click to view similar products for [MOSFET](#) category:*

*Click to view products by [Monolithic Power Systems](#) manufacturer:*

Other Similar products are found below :

[614233C](#) [648584F](#) [IRFD120](#) [JANTX2N5237](#) [FCA20N60\\_F109](#) [FDZ595PZ](#) [2SK2545\(Q,T\)](#) [405094E](#) [423220D](#) [TPCC8103,L1Q\(CM](#)  
[MIC4420CM-TR](#) [VN1206L](#) [SBVS138LT1G](#) [614234A](#) [715780A](#) [NTNS3166NZT5G](#) [SSM6J414TU,LF\(T](#) [751625C](#) [BUK954R8-60E](#)  
[NTE6400](#) [SQJ402EP-T1-GE3](#) [2SK2614\(TE16L1,Q\)](#) [2N7002KW-FAI](#) [DMN1017UCP3-7](#) [EFC2J004NUZTDG](#) [ECH8691-TL-W](#)  
[FCAB21350L1](#) [P85W28HP2F-7071](#) [DMN1053UCP4-7](#) [NTE221](#) [NTE222](#) [NTE2384](#) [NTE2903](#) [NTE2941](#) [NTE2945](#) [NTE2946](#) [NTE2960](#)  
[NTE2967](#) [NTE2969](#) [NTE2976](#) [NTE455](#) [NTE6400A](#) [NTE2910](#) [NTE2916](#) [NTE2956](#) [NTE2911](#) [DMN2080UCB4-7](#) [TK10A80W,S4X\(S](#)  
[SSM6P69NU,LF](#) [DMP22D4UFO-7B](#)