

DESCRIPTION

The MP1470H is a high-frequency, synchronous, rectified, step-down, switch-mode converter with internal power MOSFETs. It offers a very compact solution to achieve a 2A continuous output current over a wide input supply range, with excellent load and line regulation. The MP1470H has synchronous-mode operation for higher efficiency over the output current-load range.

Current-mode operation provides fast transient response and eases loop stabilization.

Protection features include over-current protection and thermal shutdown.

The MP1470H requires a minimal number of readily-available, standard, external components and is available in a space-saving 6-pin TSOT23 package.

FEATURES

- Wide 4.5V-to-16V Operating Input Range
- 110mΩ/57mΩ Low- $R_{DS(ON)}$ Internal Power MOSFETs
- Proprietary Switching-Loss-Reduction Technique
- High-Efficiency Synchronous-Mode Operation
- Fixed 1MHz Switching Frequency at CCM mode
- Internal AAM Power-Save Mode for High Efficiency at Light Load
- Internal Soft-Start
- Over-Current Protection and Hiccup
- Thermal Shutdown
- Output Adjustable from 0.8V
- Available in a 6-pin TSOT-23 package

APPLICATIONS

- Game Consoles
- Digital Set-Top Boxes
- Flat-Panel Television and Monitors
- General Purposes

All MPS parts are lead-free and adhere to the RoHS directive. For MPS green status, please visit MPS website under Products, Quality Assurance page. "MPS" and "The Future of Analog IC Technology" are registered trademarks of Monolithic Power Systems, Inc.

TYPICAL APPLICATION

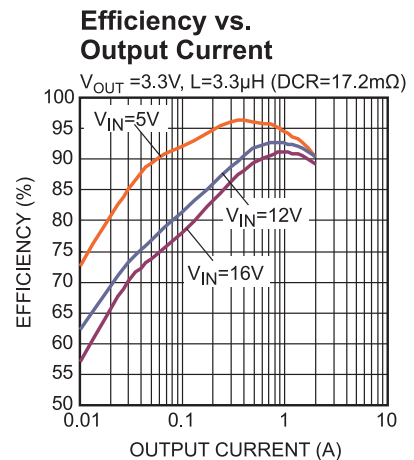
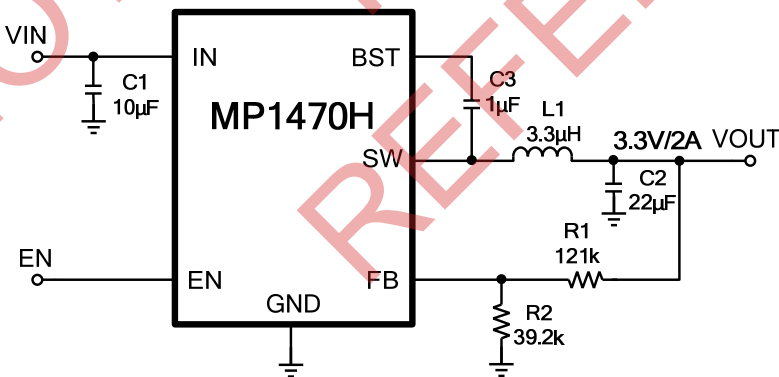

ORDERING INFORMATION

Part Number*	Package	Top Marking
MP1470HGJ	TSOT23-6	See Below

* For Tape & Reel, add suffix -Z (e.g. MP1470HGJ-Z);

TOP MARKING

| ALUY

ALU: product code of MP1470HGJ;
Y: year code;

PACKAGE REFERENCE

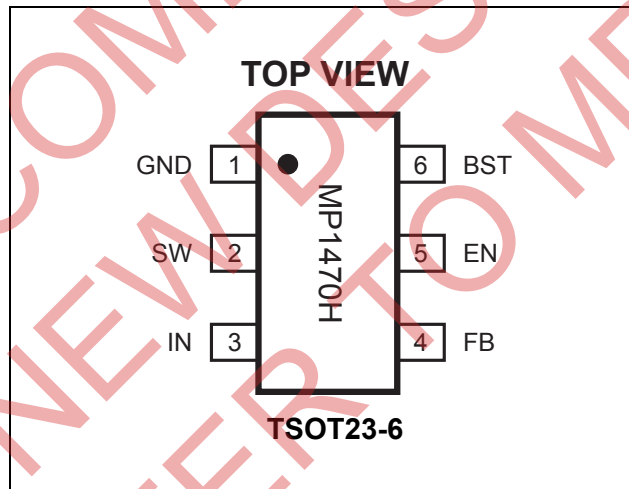

ABSOLUTE MAXIMUM RATINGS ⁽¹⁾

V_{IN}	-0.3V to 17V
V_{SW}	-0.3V (-5V for <10ns) to 17V (19V for <10ns)
V_{BST}	$V_{SW}+6V$
All Other Pins	-0.3V to 6V ⁽²⁾
Continuous Power Dissipation ($T_A = +25^\circ C$) ⁽³⁾	1.25W
Junction Temperature	150°C
Lead Temperature	260°C
Storage Temperature	-65°C to 150°C

Recommended Operating Conditions ⁽⁴⁾

Supply Voltage V_{IN}	4.5V to 16V
Output Voltage V_{OUT}	0.8V to $V_{IN} \times D_{MAX}$
Operating Junction Temp. (T_J)	-40°C to +125°C

Thermal Resistance ⁽⁵⁾	θ_{JA}	θ_{JC}
TSOT23-6	100	55... °C/W

Notes:

- 1) Exceeding these ratings may damage the device.
- 2) About the details of EN pin's ABS MAX rating, please refer to page 12, Enable section.
- 3) The maximum allowable power dissipation is a function of the maximum junction temperature T_J (MAX), the junction-to-ambient thermal resistance θ_{JA} , and the ambient temperature T_A . The maximum allowable continuous power dissipation at any ambient temperature is calculated by P_D (MAX) = $(T_J$ (MAX) - T_A) / θ_{JA} . Exceeding the maximum allowable power dissipation will cause excessive die temperature, and the regulator will go into thermal shutdown. Internal thermal shutdown circuitry protects the device from permanent damage.
- 4) The device is not guaranteed to function outside of its operating conditions.
- 5) Measured on JESD51-7, 4-layer PCB.

NOT RECOMMENDED FOR NEW DESIGNS REFER TO MP1470H

ELECTRICAL CHARACTERISTICS

$V_{IN}=12V$, $T_A=25^{\circ}C$, unless otherwise noted.

Parameter	Symbol	Condition	Min	Typ	Max	Units
Supply Current (Shutdown)	I_{IN}	$V_{EN} = 0V$			1	μA
Supply Current (Quiescent)	I_q	$V_{EN} = 2V, V_{FB} = 1V$		0.83		mA
HS Switch-On Resistance	HS_{RDS-ON}	$V_{BST-SW}=5V$		110		m Ω
LS Switch-On Resistance	LS_{RDS-ON}	$V_{CC}=5V$		57		m Ω
Switch Leakage	SW_{LKG}	$V_{EN} = 0V, V_{SW} = 12V$			1	μA
Current Limit	I_{LIMIT}	Duty=40%	3	4		A
Oscillator Frequency	f_{SW}	$V_{FB}=0.75V$	850	1000	1250	kHz
Maximum Duty Cycle	D_{MAX}	$V_{FB}=700mV$		87		%
Minimum On Time ⁽⁶⁾	T_{ON_MIN}			60		ns
Feedback Voltage	V_{FB}		788	804	820	mV
EN Rising Threshold	V_{EN_RISING}		1.4	1.5	1.6	V
EN Falling Threshold	$V_{EN_FALLING}$		1.23	1.32	1.41	V
EN Input Current	I_{EN}	$V_{EN}=2V$		1.8		μA
		$V_{EN}=0$		0		μA
V_{IN} Under-Voltage Lockout Threshold—Rising	$INUV_{Vth}$		3.9	4.15	4.4	V
V_{IN} Under-Voltage Lockout Threshold Hysteresis	$INUV_{HYS}$			340		mV
Soft-Start Period	T_{SS}	Vout from 0% to 100%		1.5		ms
Thermal Shutdown ⁽⁶⁾				150		$^{\circ}C$
Thermal Hysteresis ⁽⁶⁾				20		$^{\circ}C$

Notes:

6) Guaranteed by design.

PIN FUNCTIONS

Package Pin #	Name	Description
1	GND	System Ground. Reference ground of the regulated output voltage: requires extra care during PCB layout. Connect to GND with copper traces and vias.
2	SW	Switch Output. Connect using a wide PCB trace.
3	IN	Supply Voltage. The MP1470H operates from a 4.5V-to-16V input rail. Requires C1 to decouple the input rail. Connect using a wide PCB trace.
4	FB	Feedback. Connect to the tap of an external resistor divider from the output to GND to set the output voltage. The frequency fold-back comparator lowers the oscillator frequency when the FB voltage drops below 140mV to prevent current-limit runaway during a short circuit fault.
5	EN	EN=HIGH to enable the MP1470H. For automatic start-up, connect EN to V_{IN} using a 100k Ω resistor.
6	BST	Bootstrap. Connect a capacitor and a resistor between SW and BST pins to form a floating supply across the high-side switch driver. Use a 1 μ F BST capacitor.

NOT RECOMMENDED FOR NEW DESIGNERS REFER TO MP1470H

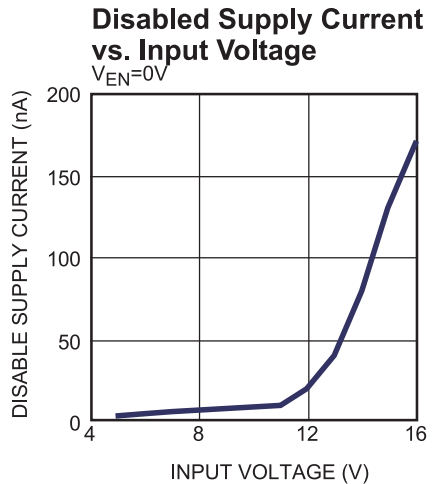
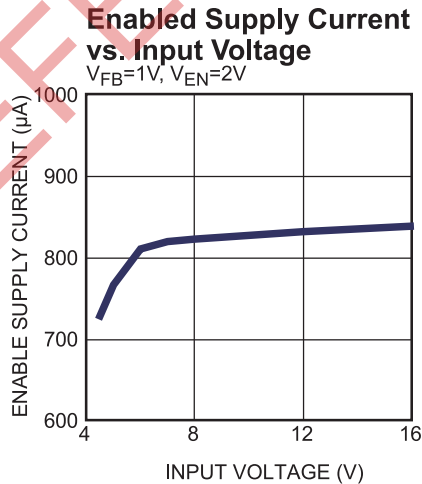
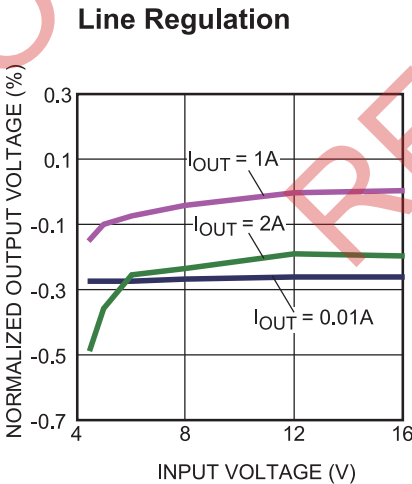
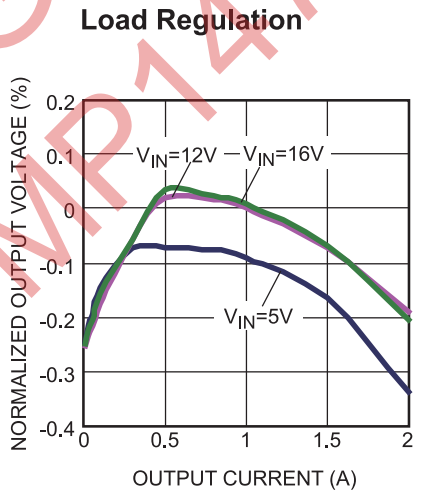
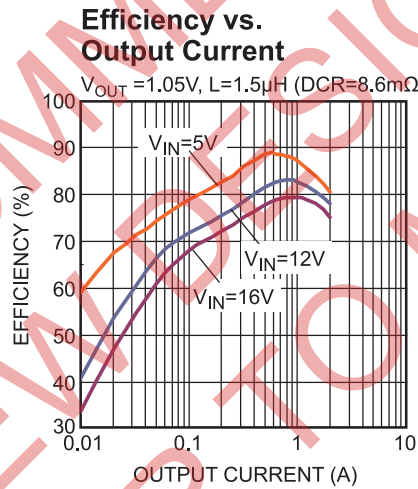
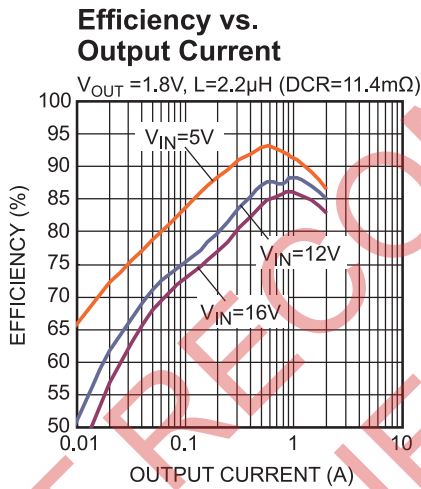
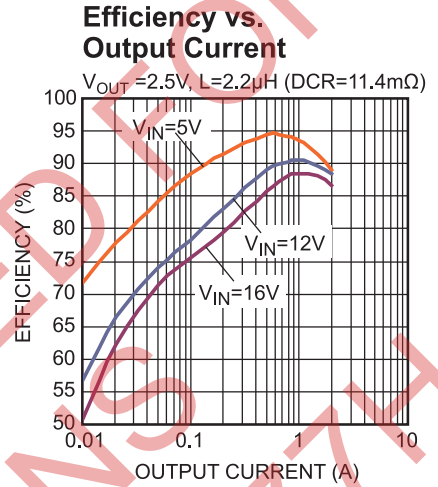
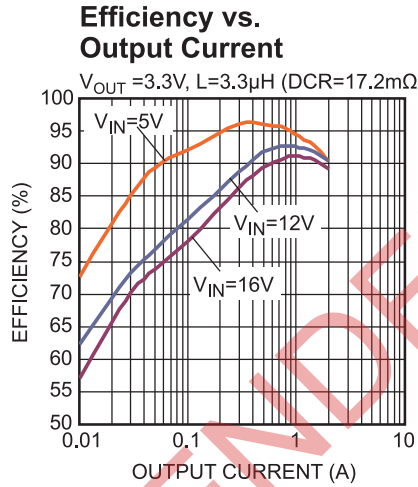
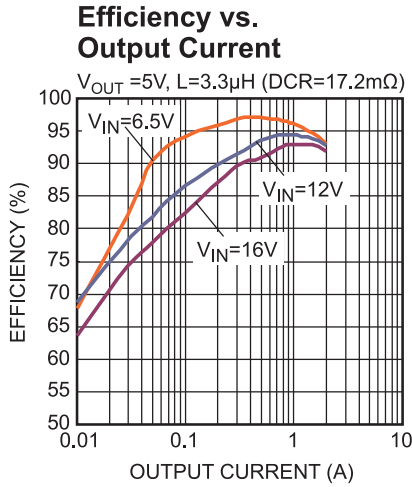
TYPICAL CHARACTERISTICS
 $V_{IN} = 12V, V_{OUT} = 3.3V, L = 3.3\mu H, T_A = +25^\circ C$, unless otherwise noted.

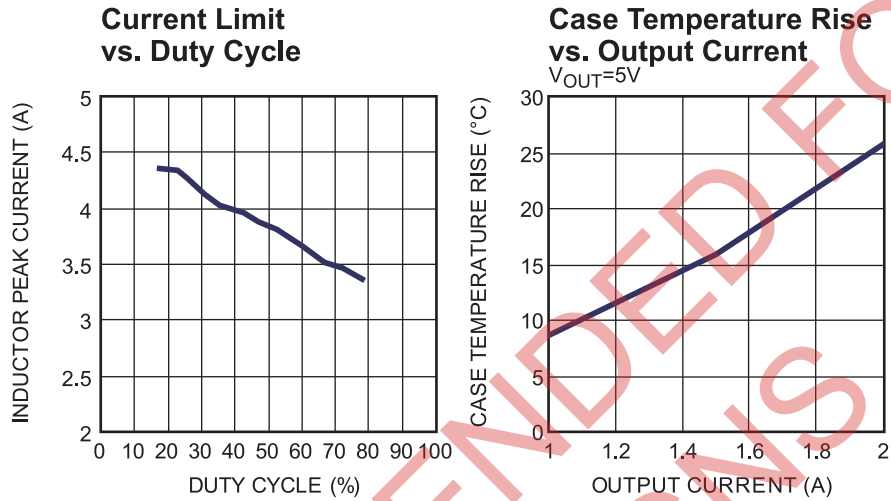
TYPICAL CHARACTERISTICS (continued)
 $V_{IN} = 12V$, $V_{OUT} = 3.3V$, $L = 3.3\mu H$, $T_A = +25^\circ C$, unless otherwise noted.

NOT RECOMMENDED FOR NEW DESIGN(S) REFER TO MP1477H

TYPICAL PERFORMANCE CHARACTERISTICS

Performance waveforms are tested on the evaluation board of the Design Example section.
 $V_{IN} = 12V$, $V_{OUT} = 3.3V$, $L = 3.3\mu H$, $T_A = +25^\circ C$, unless otherwise noted.

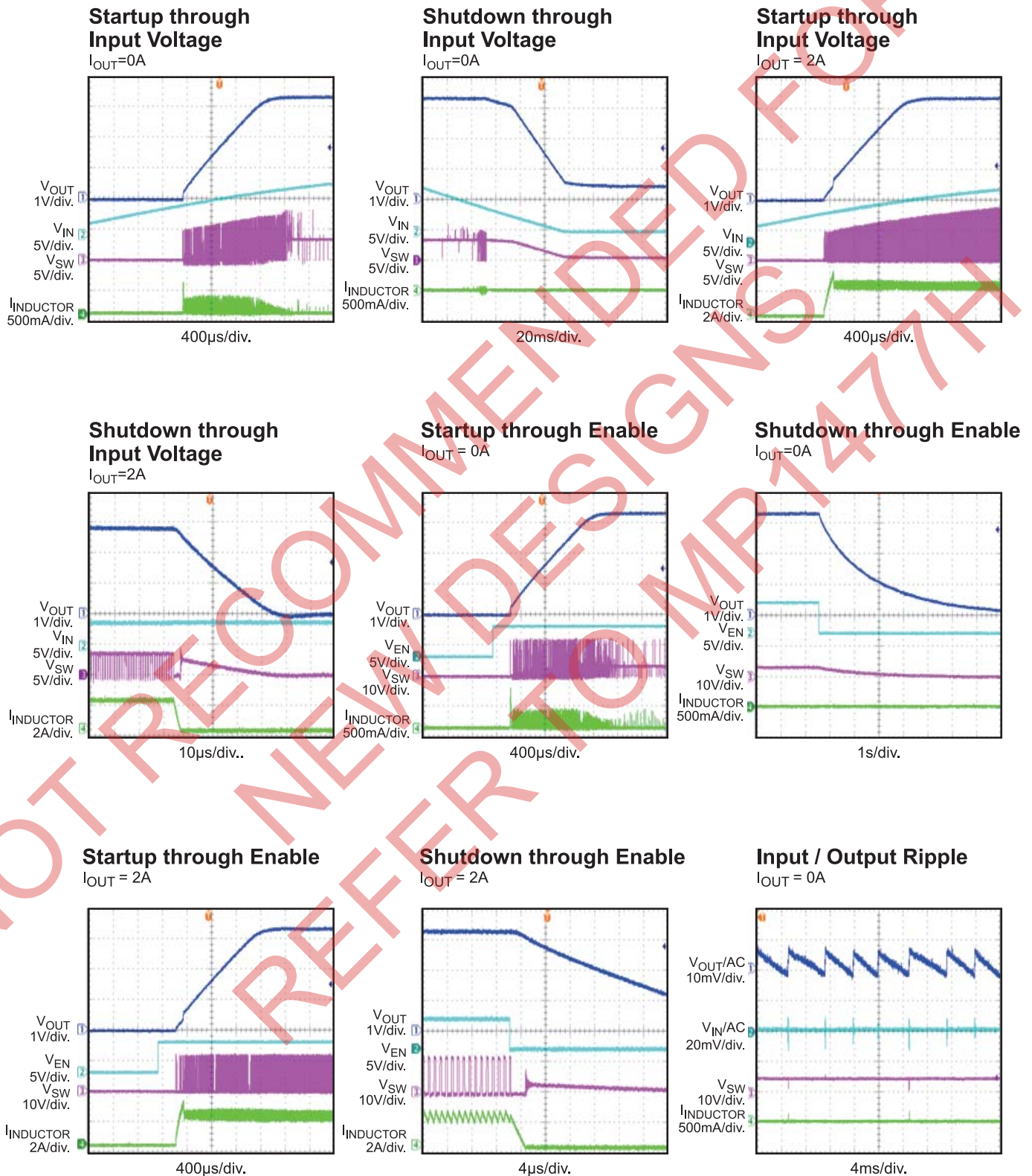

TYPICAL PERFORMANCE CHARACTERISTICS (continued)

Performance waveforms are tested on the evaluation board of the Design Example section.
 $V_{IN} = 12V$, $V_{OUT} = 3.3V$, $L = 3.3\mu H$, $T_A = +25^\circ C$, unless otherwise noted.

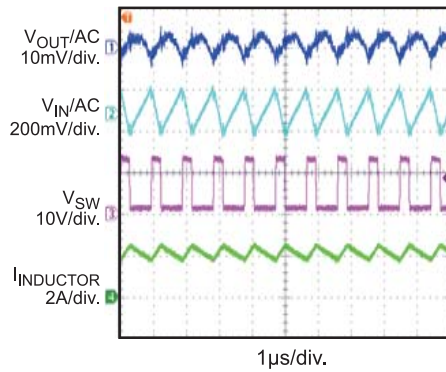
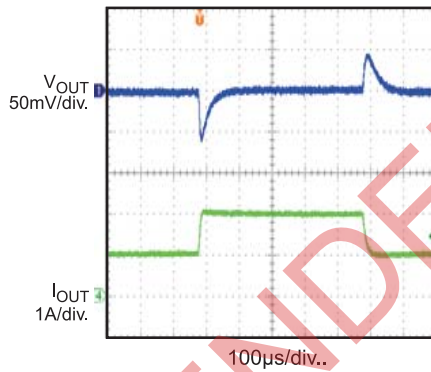
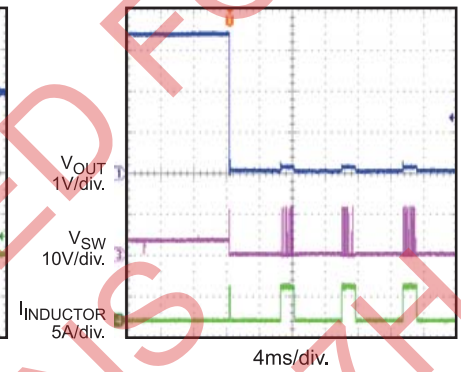
Input / Output Ripple
 $I_{OUT} = 2A$

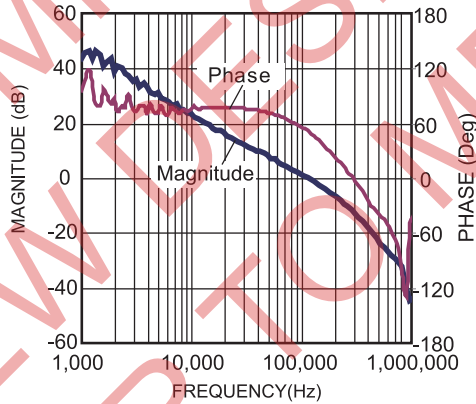
Transient Response
 $I_{OUT} = 1A-2A$, $2.5A/\mu s$

Short Circuit Entry
 $I_{OUT} = 0A$

Short Circuit Recovery
 $I_{OUT} = 0A$

Bode Plot
 $I_{OUT} = 2A$

FUNCTIONAL BLOCK DIAGRAM

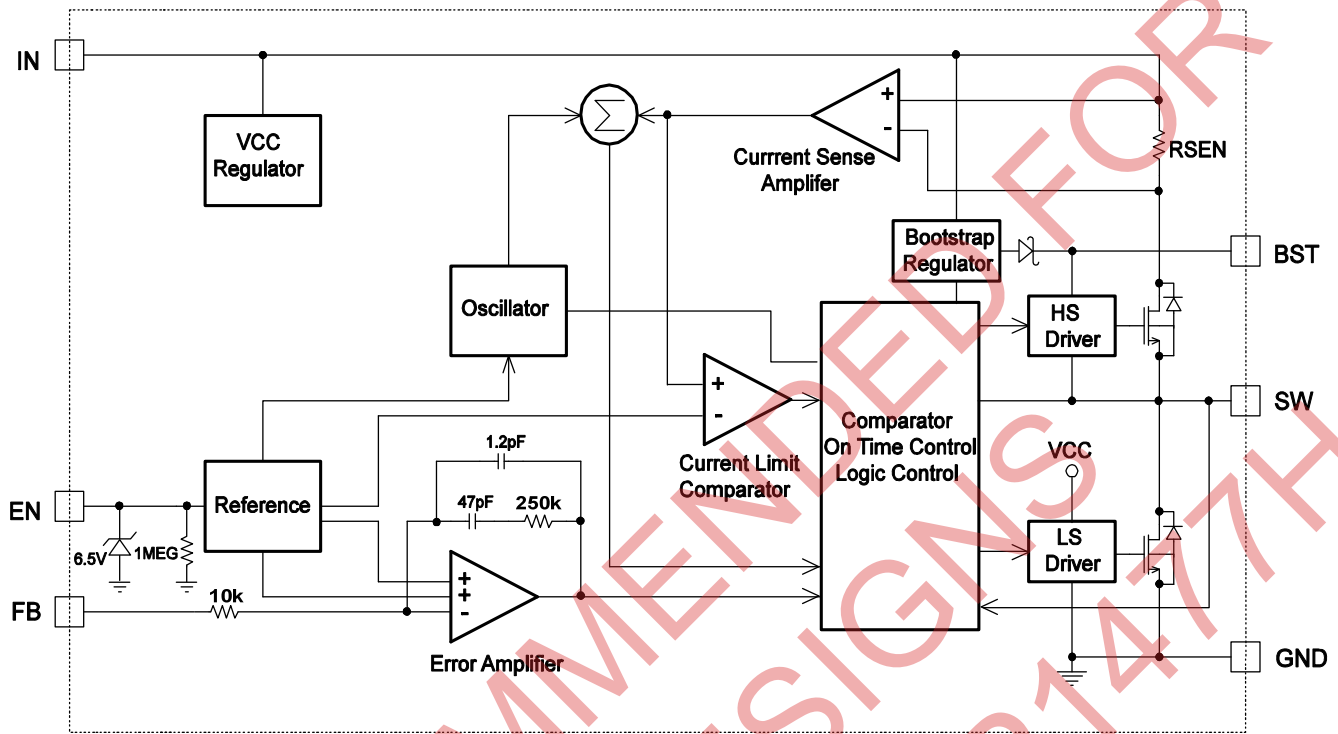

Figure 1: Functional Block Diagram

OPERATION

The MP1470H is a high-frequency, synchronous, rectified, step-down, switch-mode converter with internal power MOSFETs. It offers a very compact solution to achieve a 2A continuous output current over a wide input supply range, with excellent load and line regulation.

The MP1470H has three working modes: AAM (Advanced Asynchronous Modulation) mode, DCM (Discontinues-Conduction Mode) and CCM (Continues-Conduction Mode). The device will operate from AAM mode, DCM to CCM with the load current increasing.

AAM Control Operation

In the light load condition, MP1470H works in AAM (Advanced Asynchronous Modulation) mode. Refer to figure 2, the V_{AAM} is an internal fixed voltage when input and output voltages are fixed. V_{COMP} is the error amplifier output which represents the peak inductor current information. When V_{COMP} is lower than V_{AAM} , the internal clock is blocked, thus the MP1470H skips some pulses and achieves the light load power save. Refer to AN032 for more detail.

The internal clock resets every time when V_{COMP} is higher than V_{AAM} . At the same time the HS-FET(High-Side MOSFET) turns on and remains on until $V_{ILsense}$ reaches the value set by V_{COMP} .

The light load feature in this device is optimized for 12V input applications.

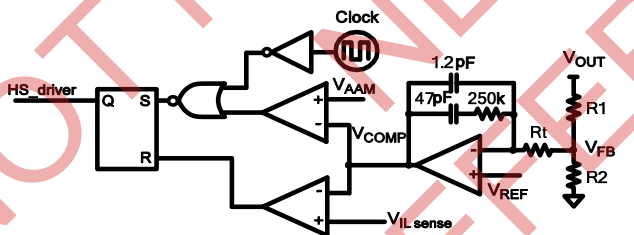

Figure 2: Simplified AAM Control Logic

DCM Control Operation

The V_{COMP} voltage ramps up with the increasing of the output current, when its minimum value exceeds V_{AAM} , the device will enter DCM (Discontinues-Conduction Mode). In this mode the internal 1MHz clock initiates the PWM cycle, the HS-FET turns on and remains on until $V_{ILsense}$ reaches the value set by V_{COMP} , after a period of dead time, the LS-FET (Low-

side MOSFET) will turn on and remain on until the inductor current value decreases to zero. The device will repeat the same operation in every clock cycle to regulate the output voltage.

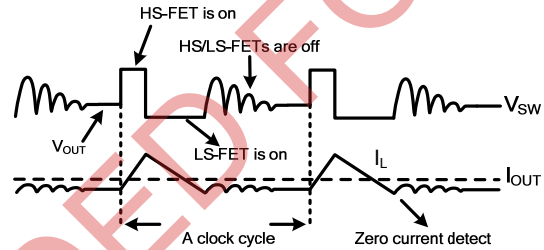

Figure 3: DCM Control Operation

CCM Control Operation

The device will enter CCM from DCM once the inductor current no longer drops to zero in a clock cycle. In CCM the internal 1MHz clock initiates the PWM cycle, the HS-FET turns on and remains on until $V_{ILsense}$ reaches the value set by V_{COMP} , after a period of dead time, the LS-FET will turn on and remain on until the next clock cycle starts. The device will repeat the same operation in every clock cycle to regulate the output voltage.

If within 87% of one PWM period, $V_{ILsense}$ does not reach the value set by V_{COMP} , the HS power MOSFET will be forced off.

Internal Regulator

The 5V internal regulator powers most of the internal circuits. This regulator takes V_{IN} and operates in the full V_{IN} range. When V_{IN} exceeds 5.0V, the regulator output is in full regulation. When V_{IN} falls below 5.0V, the output decreases.

Error Amplifier

The error amplifier compares the FB voltage against the internal 0.804V reference (REF) and outputs a current proportional to the difference between the two. This output current charges or discharges the internal compensation network to form the COMP voltage, which is used to control the power MOSFET current. The optimized internal compensation network minimizes the external component counts and simplifies the control-loop design.

Enable

EN is a digital control pin that turns the regulator on and off: Drive EN HIGH to turn on the regulator, drive it LOW to turn it off. An internal 1MΩ resistor from EN to GND allows EN to float to shut down the chip.

The EN pin is clamped internally using a 6.5V series-Zener-diode as shown in Figure 4. Connecting the EN input pin through a pull-up resistor to the V_{IN} voltage limits the EN input current to less than 100μA.

For example, with 12V connected to V_{in}, $R_{PULLUP} \geq (12V - 6.5V) \div 100\mu A = 55k\Omega$

Connecting the EN pin directly to a voltage source without any pull-up resistor requires limiting the amplitude of the voltage source to ≤ 6V to prevent damage to the Zener diode.

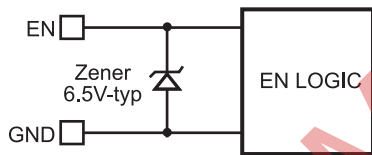

Figure 4: 6.5V Zener Diode

Under-Voltage Lockout (UVLO)

Under-voltage lockout (UVLO) protects the chip from operating at an insufficient supply voltage. The MP1470H UVLO comparator monitors the output voltage of the internal regulator, V_{CC}. The UVLO rising threshold is about 4.15V while its falling threshold is consistently 3.81V.

Internal Soft-Start

Soft-start prevents the converter output voltage from overshooting during startup. When the chip starts, the internal circuit generates a soft-start voltage (SS) that ramps up from 0V to 1.2V: When SS falls below the internal reference (REF), SS overrides REF so that the error amplifier uses SS as the reference; when SS exceeds REF, the error amplifier resumes using REF as its reference. The SS time is internally set to 1.5ms.

Pre-Bias Startup

The MP1470H has been designed for monotonic startup into pre-biased output voltage. If the output is pre-biased to a certain voltage during startup, the voltage on the soft-start capacitor will be charged. When the soft-

start capacitor's voltage exceeds the sensed output voltage at the FB pin, the part starts to turn on high side and low side power switches sequentially. Output voltage starts to ramp up following with soft-start slew rate.

Over-Current-Protection and Hiccup

The MP1470H has a cycle-by-cycle over-current limit for when the inductor current peak value exceeds the set current-limit threshold. First, when the output voltage drops until FB falls below the Under-Voltage (UV) threshold (typically 140mV) to trigger a UV event, the MP1470H enters hiccup mode to periodically restart the part. This protection mode is especially useful when the output is dead-shortened to ground. This greatly reduces the average short-circuit current to alleviate thermal issues and to protect the regulator. The MP1470H exits hiccup mode once the over-current condition is removed.

Thermal Shutdown

Thermal shutdown prevents the chip from operating at exceedingly high temperatures. When the silicon die temperature exceeds 150°C, it shuts down the whole chip. When the temperature falls below its lower threshold (typically 130°C) the chip is enabled again.

Floating Driver and Bootstrap Charging

An external bootstrap capacitor powers the floating power MOSFET driver. This floating driver has its own UVLO protection, with a rising threshold of 2.2V and a hysteresis of 150mV. V_{IN} regulates the bootstrap capacitor voltage internally through D1, M1, R4, C3, L1 and C2 (Figure 5). If (V_{IN}-V_{SW}) exceeds 5V, U2 will regulate M1 to maintain a 5V BST voltage across C3.

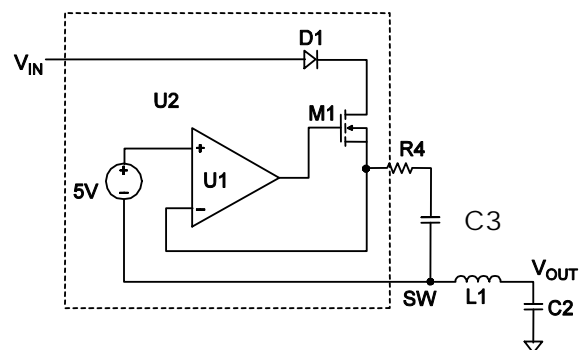

Figure 5: Internal Bootstrap Charger Circuit

Start-Up and Shutdown

If both V_{IN} and EN exceed their respective thresholds, the chip starts. The reference block starts first, generating stable reference voltage and currents, and then the internal regulator is enabled. The regulator provides a stable supply for the remaining circuits.

Three events can shut down the chip: EN low, V_{IN} low, and thermal shutdown. The shutdown procedure starts by initially blocking the signaling path to avoid any fault triggering. The COMP voltage and the internal supply rail are then pulled down. The floating driver is not subject to this shutdown command.

NOT RECOMMENDED FOR
NEW DESIGNS
REFER TO MP1477H

Application Information

Setting the Output Voltage

The external resistor divider sets the output voltage. The feedback resistor R1 also sets the feedback-loop bandwidth through the internal compensation capacitor (see the Typical Application circuit). Choose R1 and R2 with:

$$R2 = \frac{R1}{\frac{V_{OUT}}{0.804} - 1}$$

Use a T-type network when V_{OUT} is low.

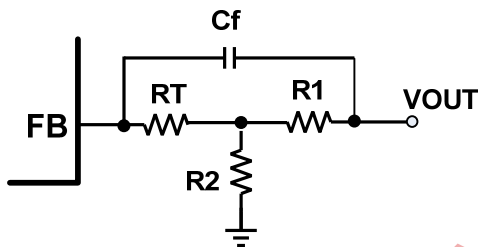

Figure 6: T-Type Network

Table 1 lists the recommended T-type resistors and forward feedback capacitors value for common output voltages.

Table 1: Resistor Selection for Common Output Voltages⁽⁷⁾

V_{OUT} (V)	R1 (k Ω)	R2 (k Ω)	RT (k Ω)	Cf (pF)
1.05	10(1%)	33.2(1%)	100	5.6
1.2	20.5(1%)	42.2(1%)	75	5.6
1.8	82(1%)	66.5(1%)	20	10
2.5	121(1%)	57.6(1%)	0	8.2
3.3	121(1%)	39.2(1%)	0	8.2
5	82(1%)	15.8(1%)	0	10

Notes:

7) The recommended parameters is basing on 12V input voltage and 22 μ F output capacitor, different input voltage and output capacitor value may affect the selection of R1, R2, RT, Cf. For other components' parameters, please refer to TYPICAL APPLICATION CIRCUITS on page 17.

Selecting the Inductor

Use a 1 μ H-to-10 μ H inductor with a DC current rating of at least 25% percent higher than the maximum load current for most applications. For highest efficiency, select an inductor with a DC resistance less than 15m Ω . For most designs, derive the inductance value from the following equation.

$$L_1 = \frac{V_{OUT} \times (V_{IN} - V_{OUT})}{V_{IN} \times \Delta I_L \times f_{OSC}}$$

Where ΔI_L is the inductor ripple current. Choose an inductor current approximately 40% of the maximum load current. The maximum inductor peak current is:

$$I_{L(MAX)} = I_{LOAD} + \frac{\Delta I_L}{2}$$

Under light-load conditions (below 100mA), use a larger inductor to improve efficiency.

Selecting the Input Capacitor

The input current to the step-down converter is discontinuous, and therefore requires a capacitor to both supply the AC current to the step-down converter and maintain the DC input voltage. For the best performance, use low ESR capacitors, such as ceramic capacitors with X5R or X7R dielectrics and small temperature coefficients. A 10 μ F capacitor is sufficient for most applications.

The input capacitor (C1) requires an adequate ripple current rating because it absorbs the input switching. Estimate the RMS current in the input capacitor with:

$$I_{CI} = I_{LOAD} \times \sqrt{\frac{V_{OUT}}{V_{IN}} \times \left(1 - \frac{V_{OUT}}{V_{IN}}\right)}$$

The worst-case condition occurs at $V_{IN} = 2V_{OUT}$, where:

$$I_{CI} = \frac{I_{LOAD}}{2}$$

For simplification, choose an input capacitor with an RMS current rating greater than half the maximum load current.

The input capacitor can be electrolytic, tantalum, or ceramic. Place a small, high-quality, ceramic capacitor (0.1 μ F) as close to the IC as possible when using electrolytic or tantalum capacitors. When using ceramic capacitors, make sure that they have enough capacitance to provide sufficient charge to prevent excessive input voltage ripple. Estimate the input voltage ripple caused by the capacitance with:

$$\Delta V_{IN} = \frac{I_{LOAD}}{f_s \times C1} \times \frac{V_{OUT}}{V_{IN}} \times \left(1 - \frac{V_{OUT}}{V_{IN}}\right)$$

Selecting the Output Capacitor

The output capacitor (C2) maintains the DC output voltage. Use ceramic, tantalum, or low-ESR electrolytic capacitors. Use low ESR capacitors to limit the output voltage ripple. Estimate the output voltage ripple with:

$$\Delta V_{OUT} = \frac{V_{OUT}}{f_s \times L_1} \times \left(1 - \frac{V_{OUT}}{V_{IN}}\right) \times \left(R_{ESR} + \frac{1}{8 \times f_s \times C2}\right)$$

Where L_1 is the inductor value and R_{ESR} is the equivalent series resistance (ESR) of the output capacitor.

For ceramic capacitors, the capacitance dominates the impedance at the switching frequency and causes most of the output voltage ripple. For simplification, estimate the output voltage ripple with:

$$\Delta V_{OUT} = \frac{V_{OUT}}{8 \times f_s^2 \times L_1 \times C2} \times \left(1 - \frac{V_{OUT}}{V_{IN}}\right)$$

For tantalum or electrolytic capacitors, the ESR dominates the impedance at the switching frequency. For simplification, the output ripple can be approximated with:

$$\Delta V_{OUT} = \frac{V_{OUT}}{f_s \times L_1} \times \left(1 - \frac{V_{OUT}}{V_{IN}}\right) \times R_{ESR}$$

The characteristics of the output capacitor also affect the stability of the regulation system. The MP1470H can be optimized for a wide range of capacitance and ESR values.

External Bootstrap Diode

An external bootstrap (BST) diode can enhance the efficiency of the regulator given the following applicable conditions:

- V_{OUT} is 5V or 3.3V; and
- Duty cycle is high: $D = \frac{V_{OUT}}{V_{IN}} > 65\%$

Connect the external BST diode from the output of voltage regulator to the BST pin, as shown in Figure 7.

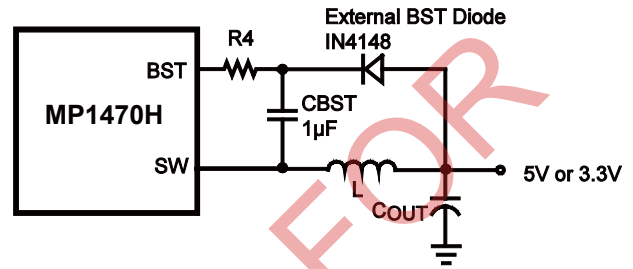

Figure 7: Optional External Bootstrap Diode

For most applications, use an 1N4148 for the external BST diode. A 1µF capacitor for the BST capacitor.

PC BOARD LAYOUT

PCB layout is very important to achieve stable operation. For best results, use the following guidelines and Figure 8 as reference.

- 1) Keep the connection between the input ground and GND pin as short and wide as possible.
- 2) Keep the connection between the input capacitor and IN pin as short and wide as possible.
- 3) Use short and direct feedback connections. Place the feedback resistors and compensation components as close to the chip as possible.
- 4) Route SW away from sensitive analog areas such as FB.

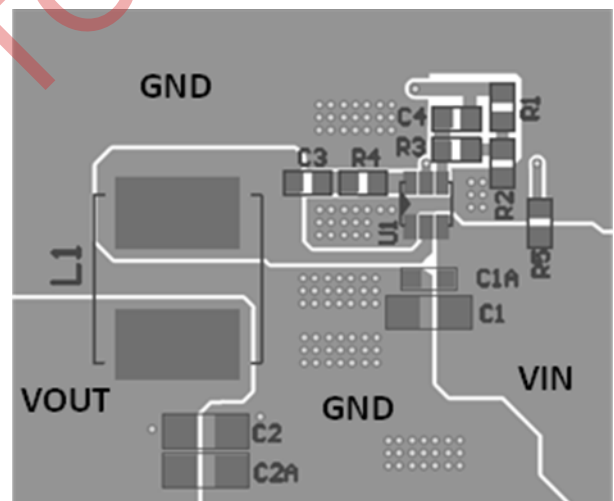

Top Layer

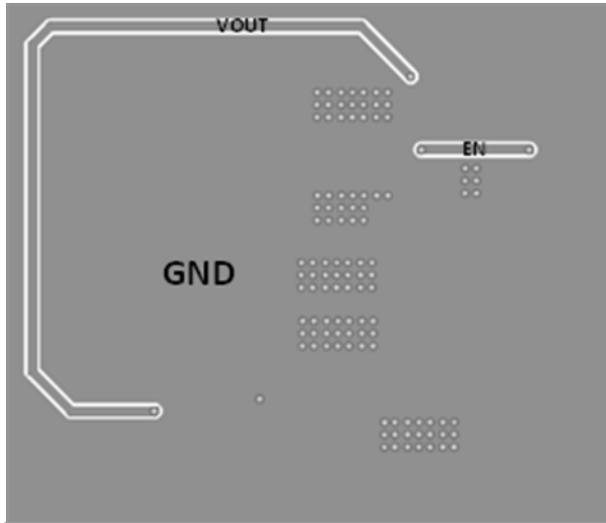
Bottom Layer
Figure 8: Sample Board Layout
Design Example

Below is a design example following the application guidelines for the specifications:

Table 2: Design Example

V_{IN}	12V
V_{OUT}	3.3V
I_o	2A

The detailed application schematics are shown in Figures 10. The typical performance and circuit waveforms have been shown in the Typical Performance Characteristics section. For more device applications, please refer to the related Evaluation Board Datasheets.

NOT RECOMMENDED FOR NEW DESIGNS REFER TO MP1470H

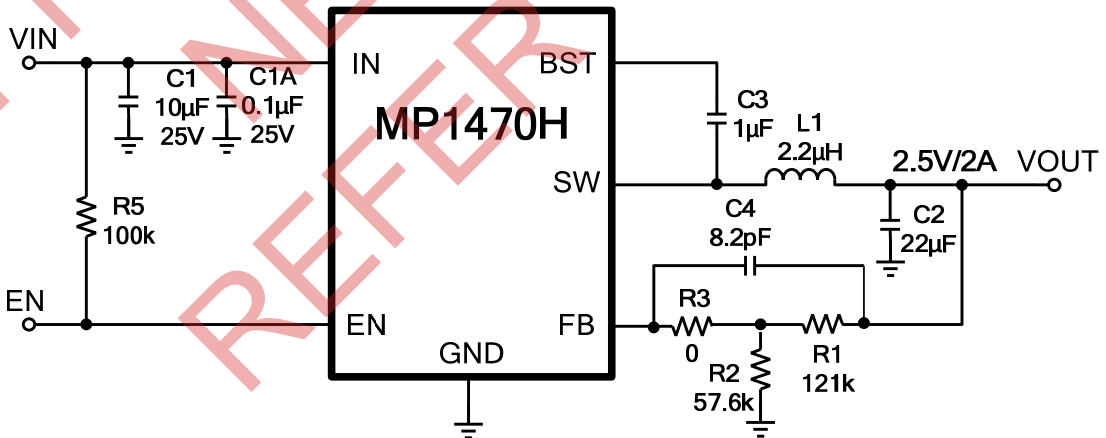
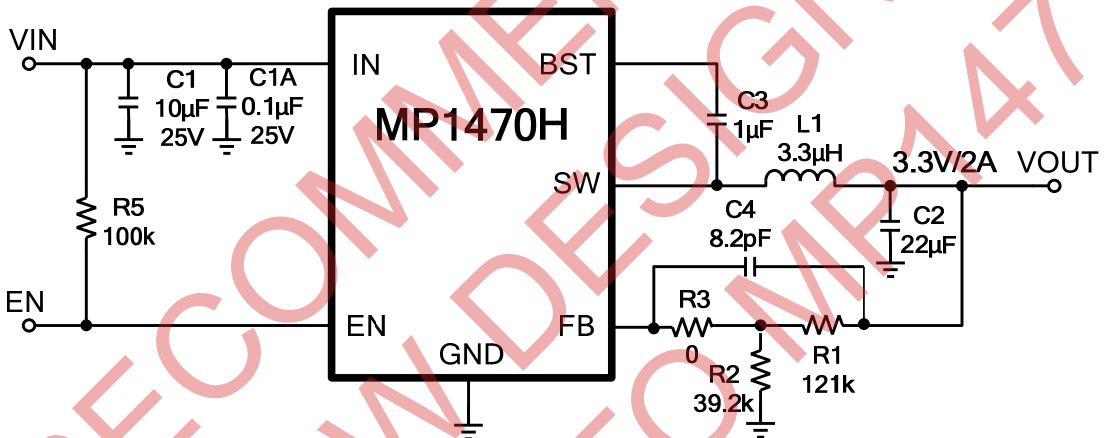
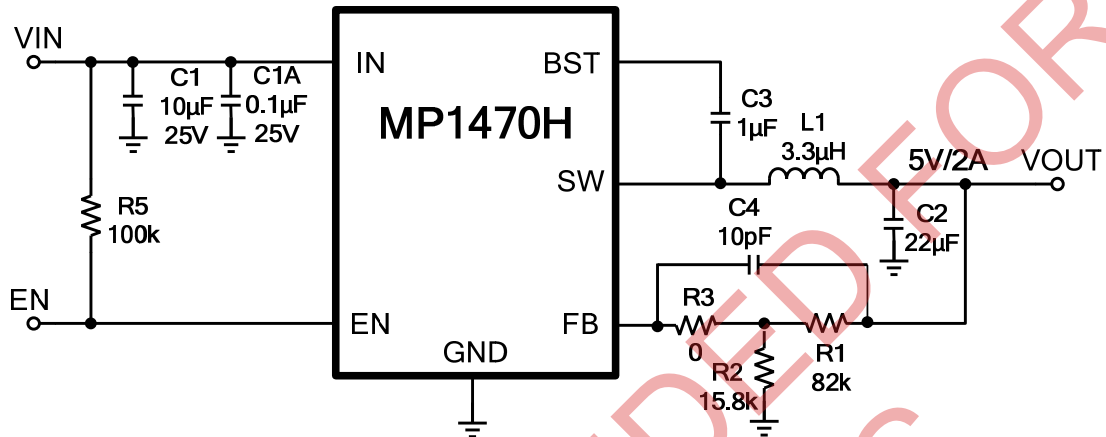
TYPICAL APPLICATION CIRCUITS

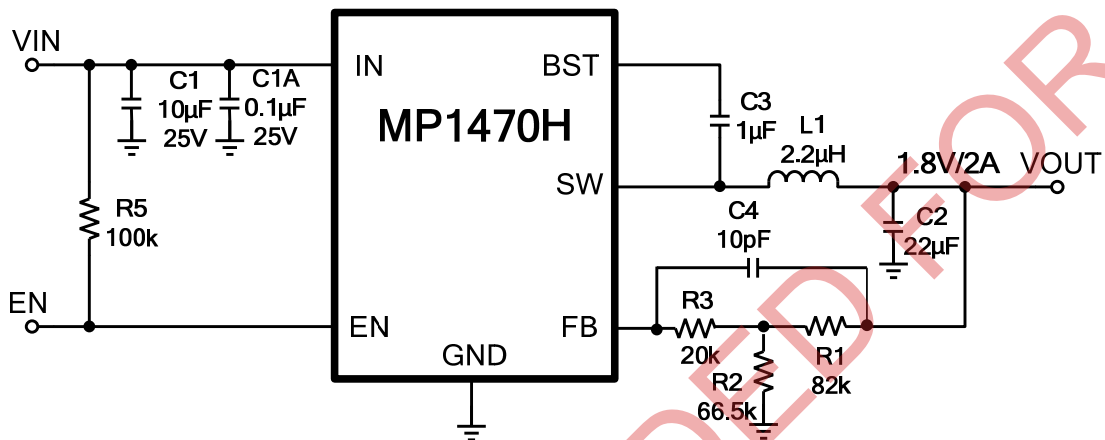

Figure 12: 12Vin, 1.8V/2A

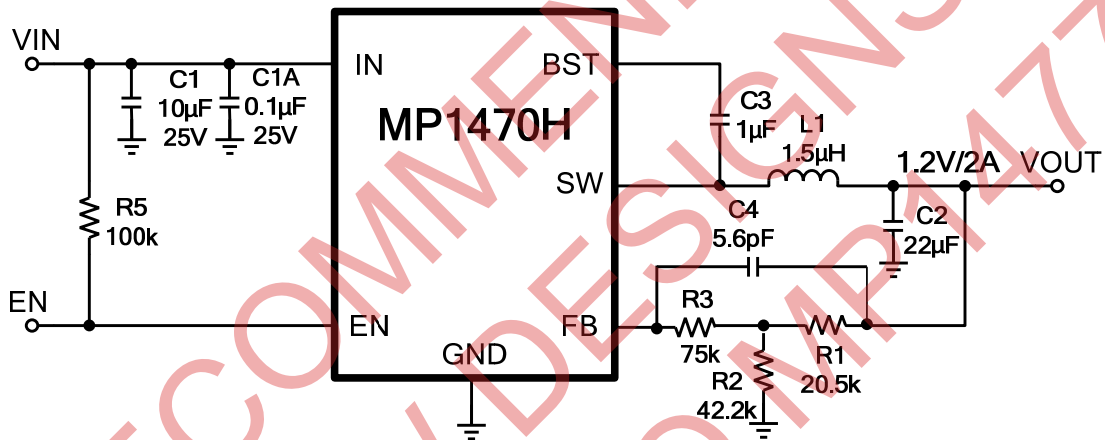

Figure 13: 12Vin, 1.2V/2A

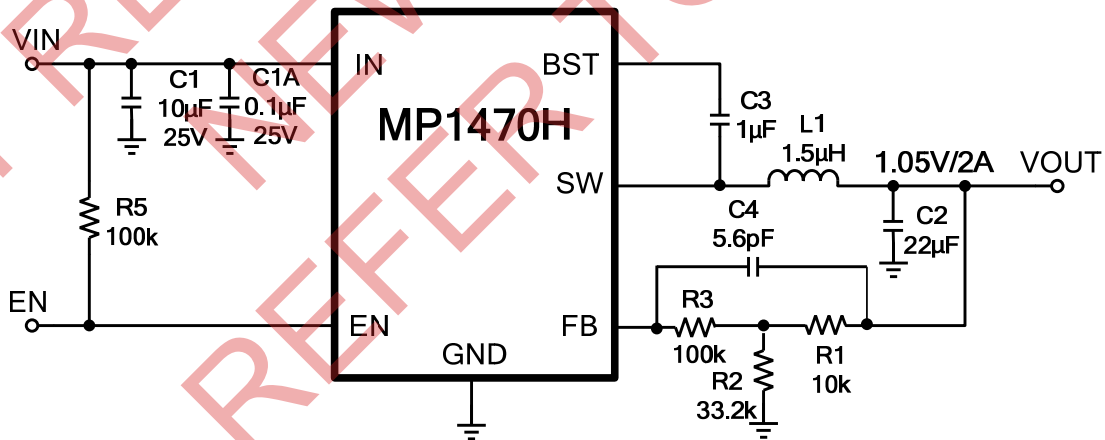
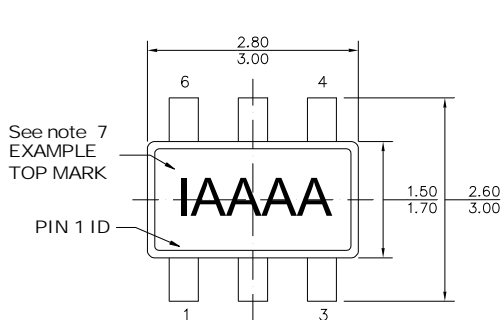
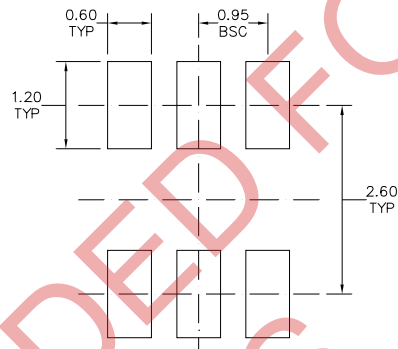
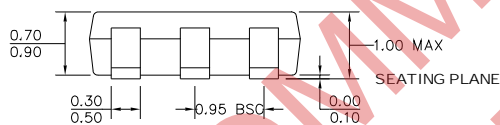
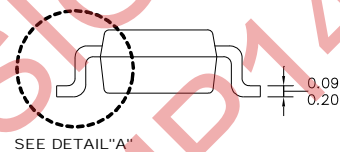
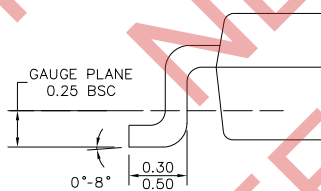

Figure 14: 12Vin, 1.05V/2A

PACKAGE INFORMATION
TSOT23-6

TOP VIEW

RECOMMENDED LAND PATTERN

FRONT VIEW

SIDE VIEW
NOTE:

- 1) ALL DIMENSIONS ARE IN MILLIMETERS
- 2) PACKAGE LENGTH DOES NOT INCLUDE MOLD FLASH, PROTRUSION OR GATE BURR
- 3) PACKAGE WIDTH DOES NOT INCLUDE INTERLEAD FLASH OR PROTRUSION
- 4) LEAD COPLANARITY (BOTTOM OF LEADS AFTER FORMING) SHALL BE 0.10 MILLIMETERS MAX
- 5) DRAWING CONFORMS TO JEDEC MO-193, VARIATION AB
- 6) DRAWING IS NOT TO SCALE
- 7) PIN 1 IS LOWER LEFT PIN WHEN READING TOP MARK FROM LEFT TO RIGHT, (SEE EXAMPLE TOP MARK)

DETAIL "A"

NOTICE: The information in this document is subject to change without notice. Users should warrant and guarantee that third party Intellectual Property rights are not infringed upon when integrating MPS products into any application. MPS will not assume any legal responsibility for any said applications.

X-ON Electronics

Largest Supplier of Electrical and Electronic Components

Click to view similar products for [Switching Voltage Regulators](#) category:

Click to view products by [Monolithic Power Systems](#) manufacturer:

Other Similar products are found below :

[LV5695P-E](#) [FAN53610AUC33X](#) [FAN53611AUC123X](#) [EN6310QA](#) [160215](#) [R3](#) [KE177614](#) [FAN53611AUC12X](#) [MAX809TTR](#)
[AST1S31PUR](#) [NCP81203PMNTXG](#) [NCP81208MNTXG](#) [NCP81109GMNTXG](#) [NCP3235MNTXG](#) [NCP81109JMNTXG](#) [MP2161AGJ-Z](#)
[NCP81241MNTXG](#) [NTE7223](#) [NTE7222](#) [NTE7224](#) [L6986FTR](#) [MPQ4481GU-AEC1-P](#) [MP8756GD-P](#) [MPQ2171GJ-P](#) [MPQ2171GJ-AEC1-P](#)
[NJW4153U2-A-TE2](#) [MP2171GJ-P](#) [MP28160GC-Z](#) [MPM3509GQVE-AEC1-P](#) [XDPE132G5CG000XUMA1](#) [LM60440AQRPKRQ1](#)
[LT8653SEV#PBF](#) [MP5461GC-P](#) [NCV896530MWATXG](#) [MPQ4409GQBE-AEC1-P](#) [S-19903DA-A8T1U7](#) [S-19903CA-A6T8U7](#) [S-](#)
[19903CA-S8T1U7](#) [S-19902BA-A6T8U7](#) [S-19902CA-A6T8U7](#) [S-19932BA-A6T8U7](#) [S-19932AA-A6T8U7](#) [S-19932BA-A8T1U7](#) [S-](#)
[19902AA-A6T8U7](#) [S-19903AA-A6T8U7](#) [S-19902AA-S8T1U7](#) [S-19902BA-A8T1U7](#) [LMR23615QDRRRQ1](#) [LMR33630APAQRNXRQ1](#)
[LMR33630APCQRNXRQ1](#)