



The Future of Analog IC Technology®

MP1477H

17V, 3A, 1.2MHz, High-Efficiency,
Synchronous, Step-Down Converter
in a SOT563 Package

DESCRIPTION

The MP1477H is a fully integrated, high-frequency, synchronous, rectified, step-down, switch-mode converter with internal power MOSFETs. The MP1477H offers a very compact solution that achieves 3A of continuous output current with excellent load and line regulation over a wide input range. The MP1477H uses synchronous-mode operation for higher efficiency over the output current-load range.

Constant-on-time (COT) control operation provides very fast transient response, easy loop design, and very tight output regulation.

Full protection features include short-circuit protection (SCP), over-current protection (OCP), under-voltage protection (UVP), and thermal shutdown.

The MP1477H requires a minimal number of readily available, standard, external components and is available in a space-saving SOT563 (1.6mmx1.6mm) package.

FEATURES

- Wide 4.2V to 17V Operating Input Range
- 58mΩ/25mΩ Low $R_{DS(ON)}$ Internal Power MOSFETs
- 200μA Low I_Q
- High-Efficiency Synchronous Mode Operation
- Forced PWM Mode Operation
- Fast Load Transient Response
- 1.2MHz Switching Frequency
- Internal Soft Start (SS)
- Over-Current Protection (OCP) and Hiccup
- Thermal Shutdown
- Output Adjustable from 0.8V
- Available in a SOT563 (1.6mmx1.6mm) Package

APPLICATIONS

- Security Camera
- Digital Set-Top Boxes
- Flat-Panel Television and Monitors
- General Purposes

All MPS parts are lead-free, halogen-free, and adhere to the RoHS directive. For MPS green status, please visit the MPS website under Quality Assurance. "MPS" and "The Future of Analog IC Technology" are registered trademarks of Monolithic Power Systems, Inc.

TYPICAL APPLICATION

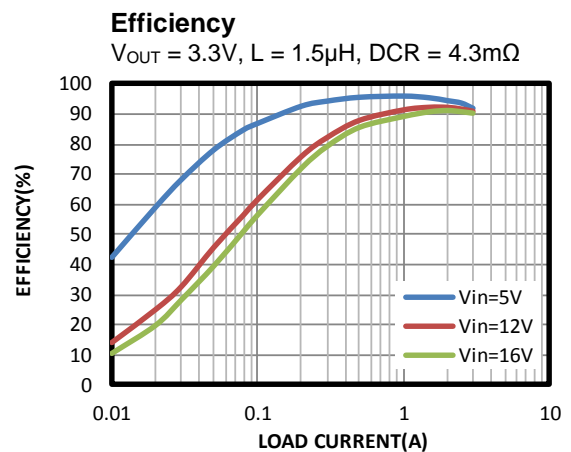
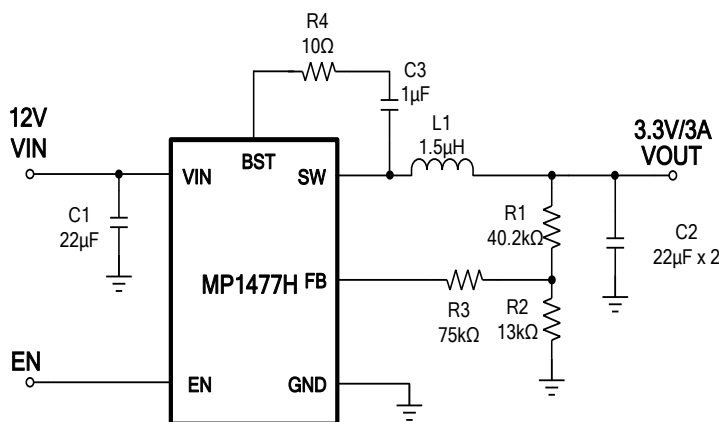

ORDERING INFORMATION

Part Number*	Package	Top Marking
MP1477HGTF	SOT563(1.6mmx1.6mm)	See Below

* For Tape & Reel, add suffix -Z (e.g. MP1477HGTF-Z).

TOP MARKING

BECY

LLL

BEC: Product code of MP1477HGTF

Y: Year code

LLL: Lot number

PACKAGE REFERENCE

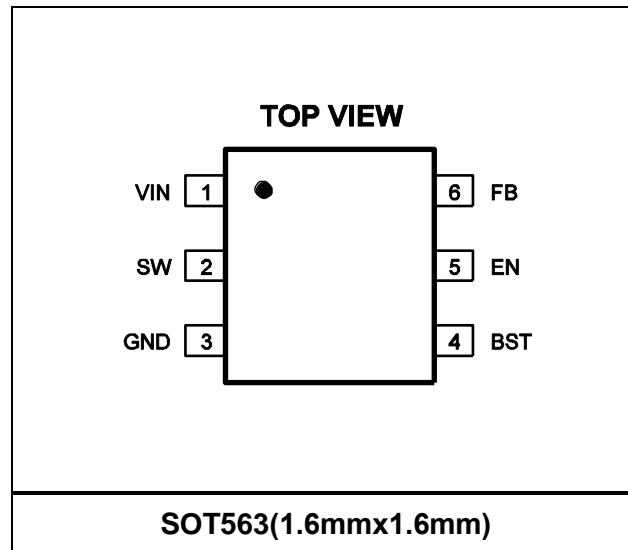

ABSOLUTE MAXIMUM RATINGS ⁽¹⁾

V _{IN}	-0.3V to 18V
V _{SW}	-0.6V (-6.5V for <10ns) to V _{IN} + 0.3V (19V for <10ns)
V _{BST}	V _{SW} + 5V
V _{EN}	-0.3V to 5V ⁽²⁾
All other pins	-0.3V to 5V
Continuous power dissipation (T _A = +25°C) ⁽³⁾⁽⁵⁾	2.2W
Junction temperature	150°C
Lead temperature	260°C
Storage temperature	-65°C to 150°C

Recommended Operating Conditions ⁽⁴⁾

Supply voltage (V _{IN})	4.2V to 17V
Output voltage (V _{OUT})	0.8V to V _{IN} x D _{MAX} or 10V max
Operating junction temp. (T _J) ...	-40°C to +125°C

Thermal Resistance

	θ_{JA}	θ_{JC}
SOT563	55	21
EV1477H-TF-00B ⁽⁵⁾	55	21
JESD51-7 ⁽⁶⁾	130	60

NOTES:

- 1) Exceeding these ratings may damage the device.
- 2) For details on EN's ABS max rating, please refer to the EN Control section on page 12.
- 3) The maximum allowable power dissipation is a function of the maximum junction temperature T_J (MAX), the junction-to-ambient thermal resistance θ_{JA} , and the ambient temperature T_A. The maximum allowable continuous power dissipation at any ambient temperature is calculated by P_D (MAX) = (T_J (MAX) - T_A) / θ_{JA} . Exceeding the maximum allowable power dissipation produces an excessive die temperature, causing the regulator to go into thermal shutdown. Internal thermal shutdown circuitry protects the device from permanent damage.
- 4) The device is not guaranteed to function outside of its operating conditions.
- 5) Measured on EV1477H-TF-00B, 2-layer PCB.
- 6) Measured on JESD51-7, 4-layer PCB.

ELECTRICAL CHARACTERISTICS

VIN = 12V, T_J = -40°C to +125°C ⁽⁷⁾, typical value is tested at T_J = +25°C, unless otherwise noted

Parameter	Symbol	Condition	Min	Typ	Max	Units
Supply current (shutdown)	I _{IN}	V _{EN} = 0V			10	μA
Supply current (quiescent)	I _Q	V _{EN} = 2V, V _{FB} = 0.85V	170	200	250	μA
HS switch on resistance	HS _{RDS(ON)}	V _{BST-SW} = 3.3V		58		mΩ
LS switch on resistance	LS _{RDS(ON)}			25		mΩ
Switch leakage	SW _{LKG}	V _{EN} = 0V, V _{SW} = 12V			10	μA
Valley current limit	I _{LIMIT}	V _{OUT} = 0V		4		A
Oscillator frequency	f _{SW}	V _{FB} = 0.75V	1000	1200	1500	kHz
Minimum on time ⁽⁸⁾	T _{ON_MIN}			45		ns
Minimum off time ⁽⁸⁾	T _{OFF_MIN}			180		ns
Feedback voltage	V _{REF}	T _J = +25°C	793	805	817	mV
Feedback voltage	V _{REF}	T _J = -40°C to 125°C	789	805	821	mV
Feedback current	I _{FB}			10	100	nA
FB UV threshold (H to L)	V _{UV_th}	Hiccup entry		44%		V _{ref}
Hiccup duty cycle ⁽⁸⁾	D _{Hiccup}			25		%
EN rising threshold	V _{EN_RISING}		1.14	1.2	1.26	V
EN hysteresis	V _{EN_HYS}			100		mV
EN input current	I _{EN}	V _{EN} = 2V		2		μA
VIN under-voltage lockout threshold rising	INUV _{Vth}		3.7	4	4.18	V
VIN under-voltage lockout threshold hysteresis	INUV _{HYS}			330		mV
Soft-start period	T _{SS}		1.6	2.5	3	ms
Thermal shutdown ⁽⁸⁾	TSD			150		°C
Thermal hysteresis ⁽⁸⁾	TSD _{HYS}			20		°C

NOTES:

- 7) Guaranteed by over-temperature correlation, not tested in production.
 8) Guaranteed by design and engineering sample characterization.

TYPICAL PERFORMANCE CHARACTERISTICS

$V_{IN} = 12V$, $V_{OUT} = 3.3V$, $L = 1.5\mu H$, $T_A = +25^\circ C$, unless otherwise noted.

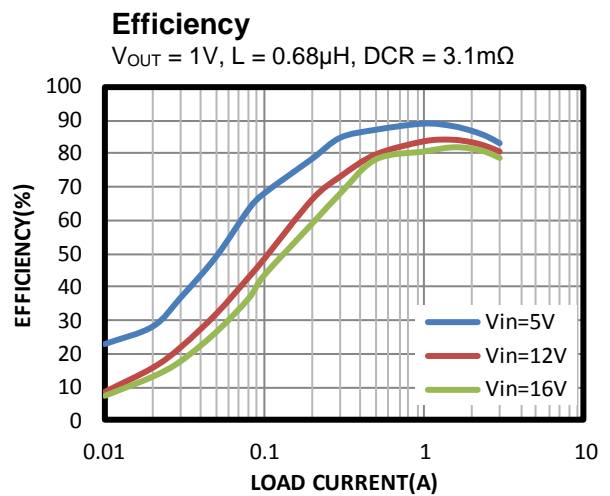
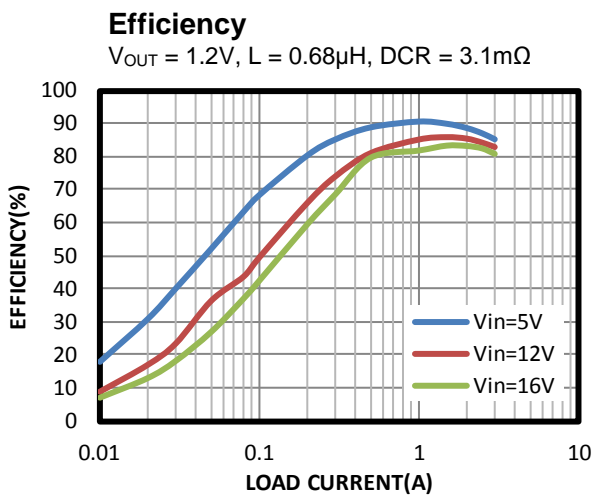
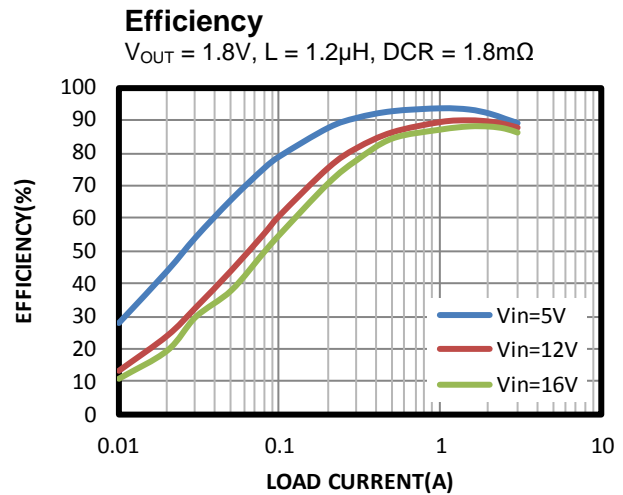
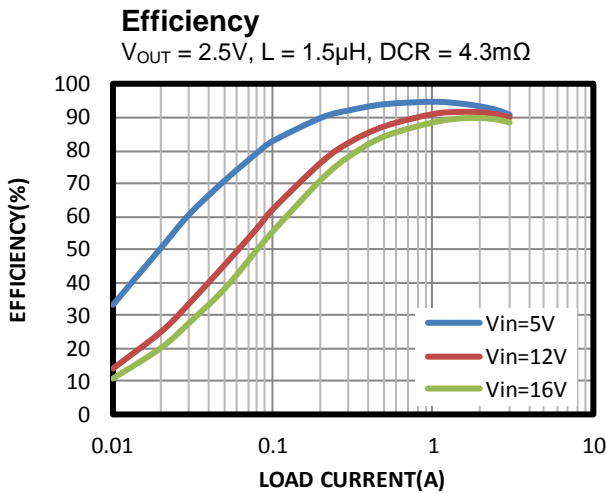
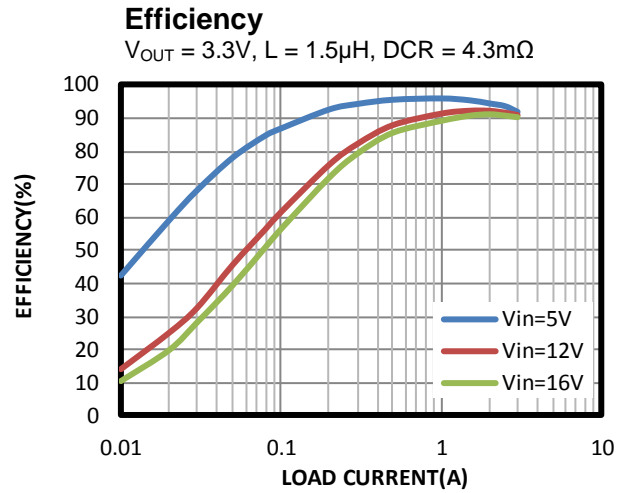
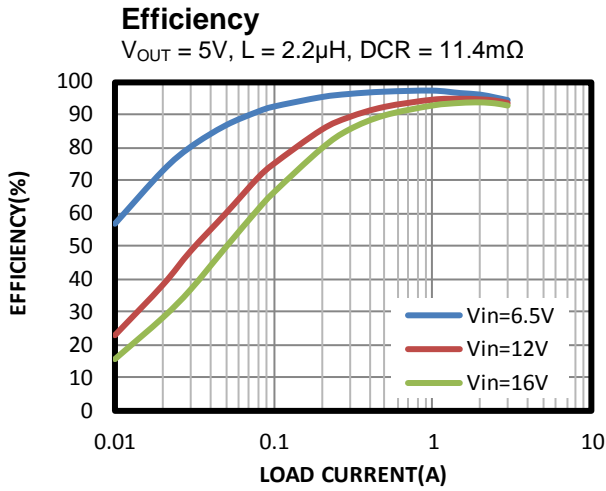

TYPICAL PERFORMANCE CHARACTERISTICS *(continued)*

$V_{IN} = 12V$, $V_{OUT} = 3.3V$, $L = 1.5\mu H$, $T_A = +25^\circ C$, unless otherwise noted.

Line Regulation

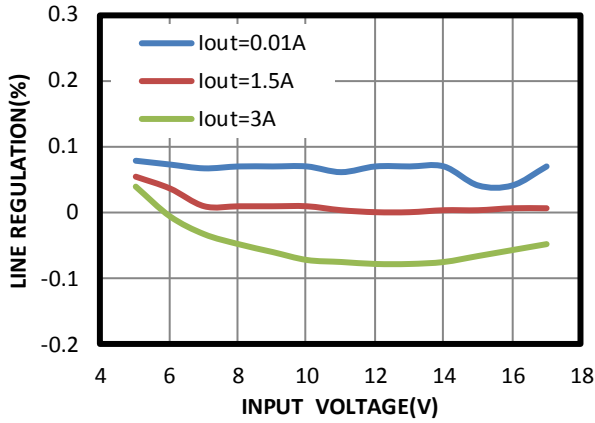

Load Regulation

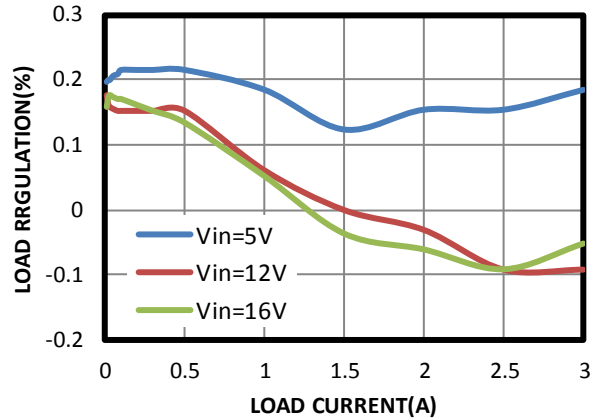

Enabled Supply Current vs. Input Voltage

$V_{EN} = 2V$, $V_{FB} = 0.85V$

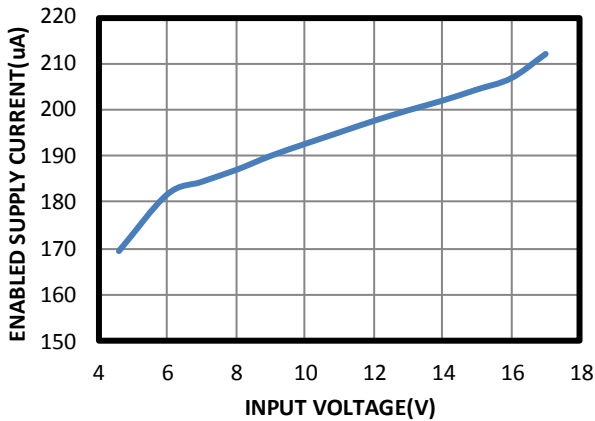

Disabled Supply Current vs. Input Voltage

$V_{EN} = 0V$

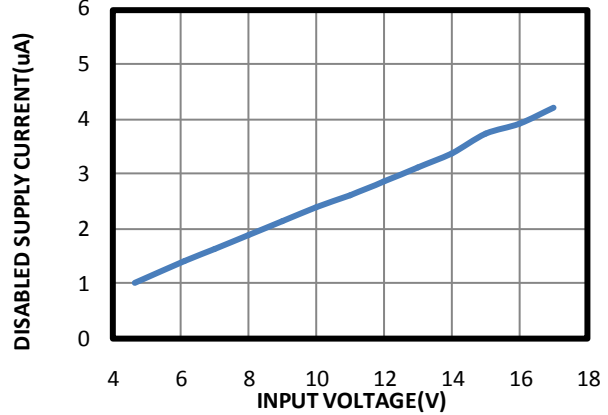

Case Temperature Rise vs. Load Current

$T_A = 25^\circ C$, board size: 6.3cm x 4.7cm

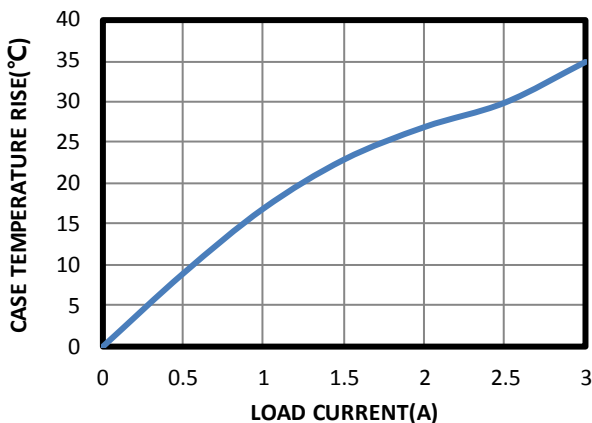

TYPICAL PERFORMANCE CHARACTERISTICS (continued)
 $V_{IN} = 12V$, $V_{OUT} = 3.3V$, $L = 1.5\mu H$, $T_A = +25^\circ C$, unless otherwise noted.

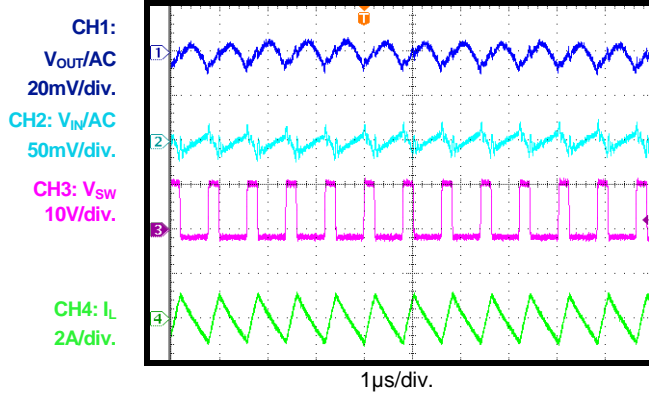
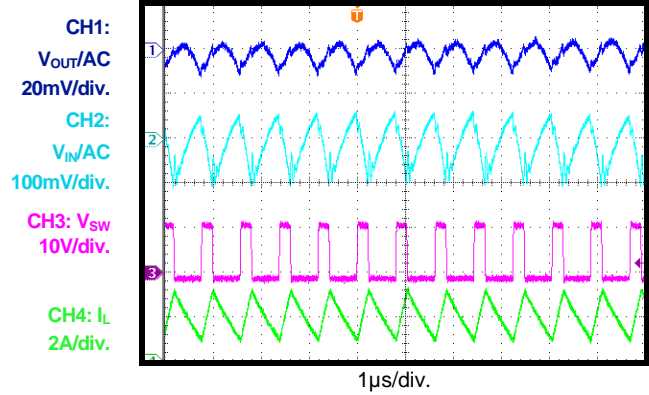
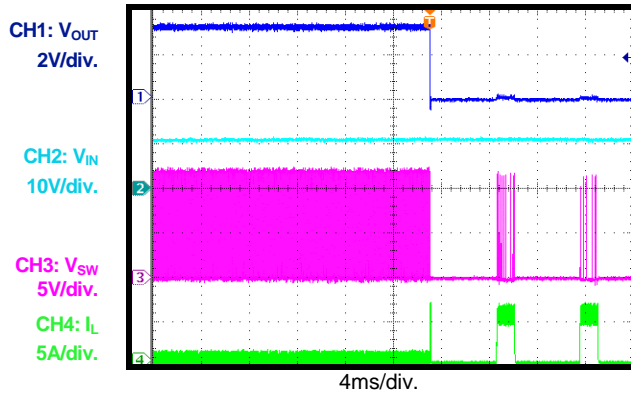
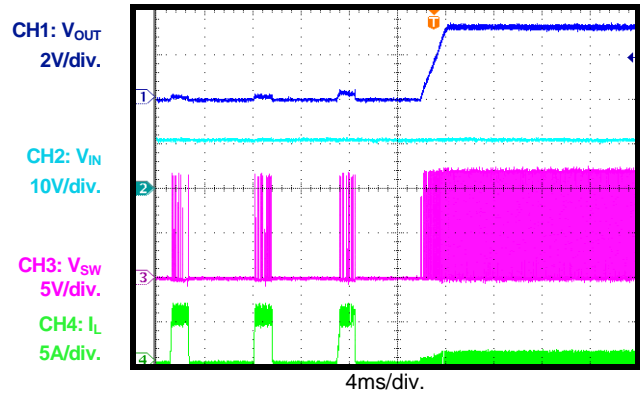
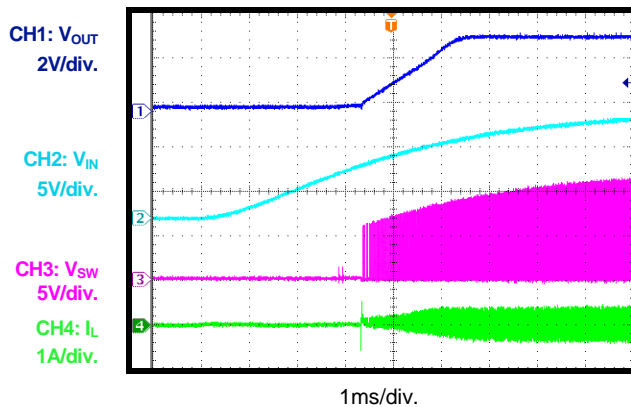
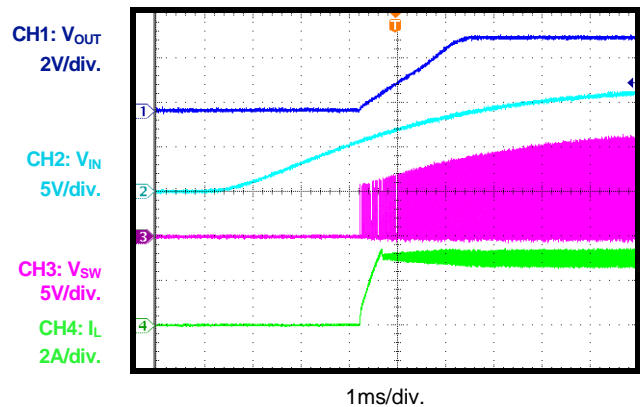
Input/Output Ripple
 $I_{OUT} = 0A$

Input/Output Ripple
 $I_{OUT} = 3A$

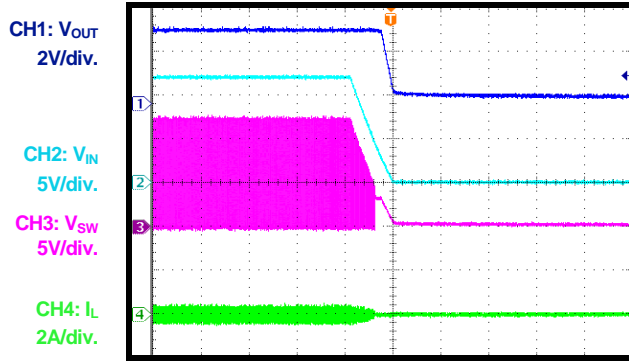
Short-Circuit Entry
 $I_{OUT} = 0A$

Short-Circuit Recovery
 $I_{OUT} = 0A$

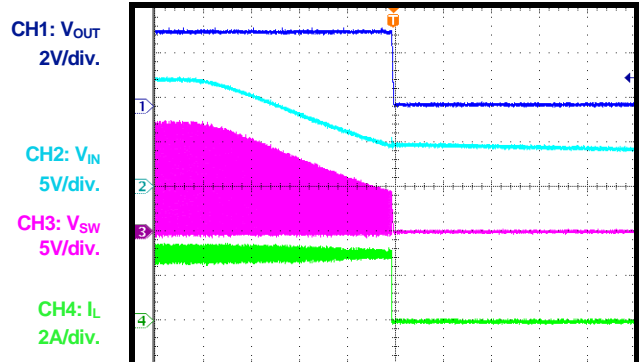
Start-Up through Input Voltage
 $I_{OUT} = 0A$

Start-Up through Input Voltage
 $I_{OUT} = 3A$

TYPICAL PERFORMANCE CHARACTERISTICS (continued)
 $V_{IN} = 12V$, $V_{OUT} = 3.3V$, $L = 1.5\mu H$, $T_A = +25^\circ C$, unless otherwise noted.

Shutdown through Input Voltage
 $I_{OUT} = 0A$

100ms/div.

Shutdown through Input Voltage
 $I_{OUT} = 3A$

1ms/div.

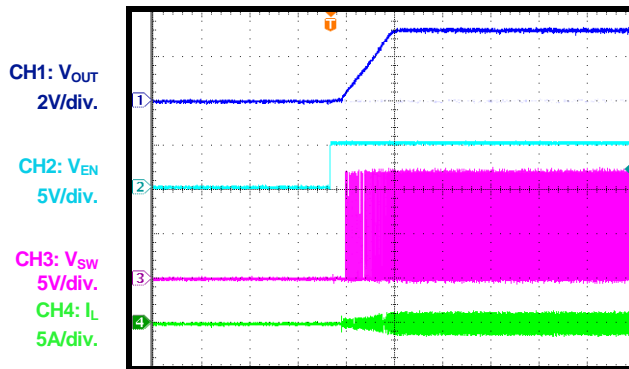
Start-Up through Enable
 $I_{OUT} = 0A$

2ms/div.

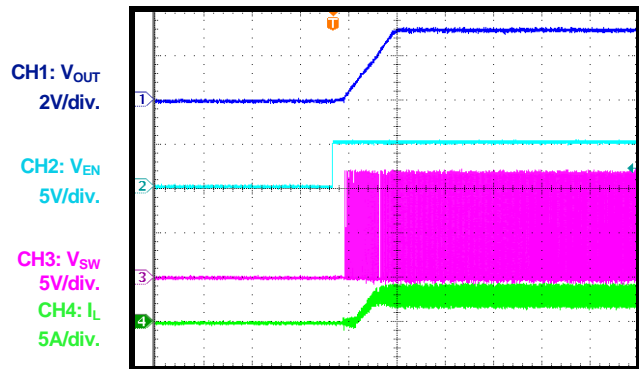
Start-Up through Enable
 $I_{OUT} = 3A$

2ms/div.

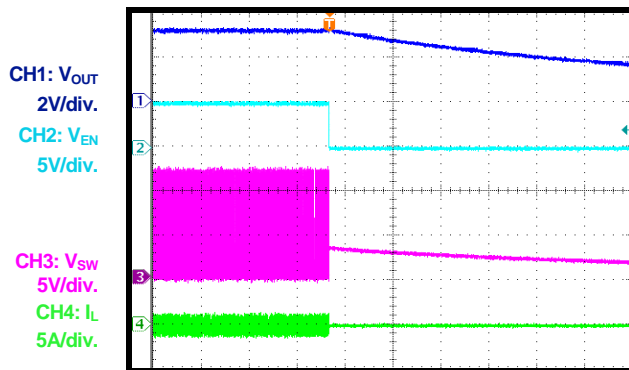
Shutdown through Enable
 $I_{OUT} = 0A$

200ms/div.

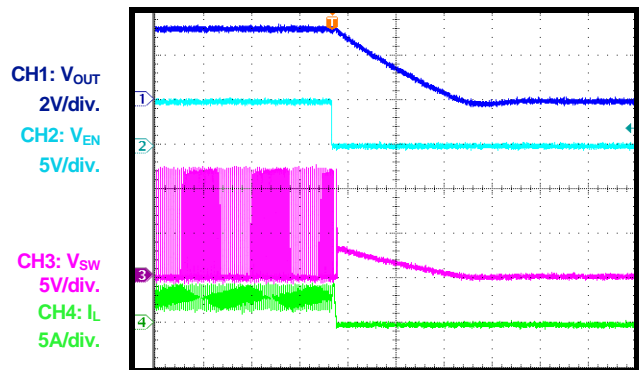
Shutdown through Enable
 $I_{OUT} = 3A$

20µs/div.

TYPICAL PERFORMANCE CHARACTERISTICS *(continued)*

$V_{IN} = 12V$, $V_{OUT} = 3.3V$, $L = 1.5\mu H$, $T_A = +25^\circ C$, unless otherwise noted.

Load Transient Response

$I_{OUT} = 1.5A$ to $3A$, $2.5A/\mu s$

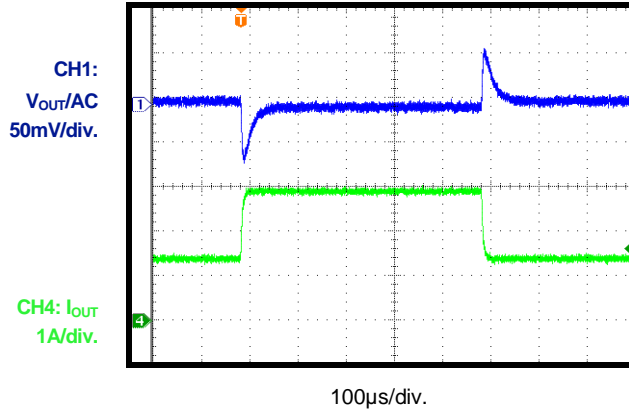

PIN FUNCTIONS

Package Pin #	Name	Description
1	VIN	Supply voltage. The MP1477H operates from a 4.2V to 17V input rail. A capacitor (C1) is required to decouple the input rail. Connect VIN using a wide PCB trace.
2	SW	Switch output. Connect SW using a wide PCB trace.
3	GND	System ground. GND is the reference ground of the regulated output voltage. GND requires careful consideration during the PCB layout. Connect GND with copper traces and vias.
4	BST	Bootstrap. Connect a 1 μ F BST capacitor and a resistor between SW and BST to form a floating supply across the high-side switch driver.
5	EN	Enable. Drive EN high to enable the MP1477H. For automatic start-up, connect EN to VIN with a 100k Ω pull-up resistor.
6	FB	Feedback. Connect FB to the tap of an external resistor divider from the output to GND to set the output voltage.

BLOCK DIAGRAM

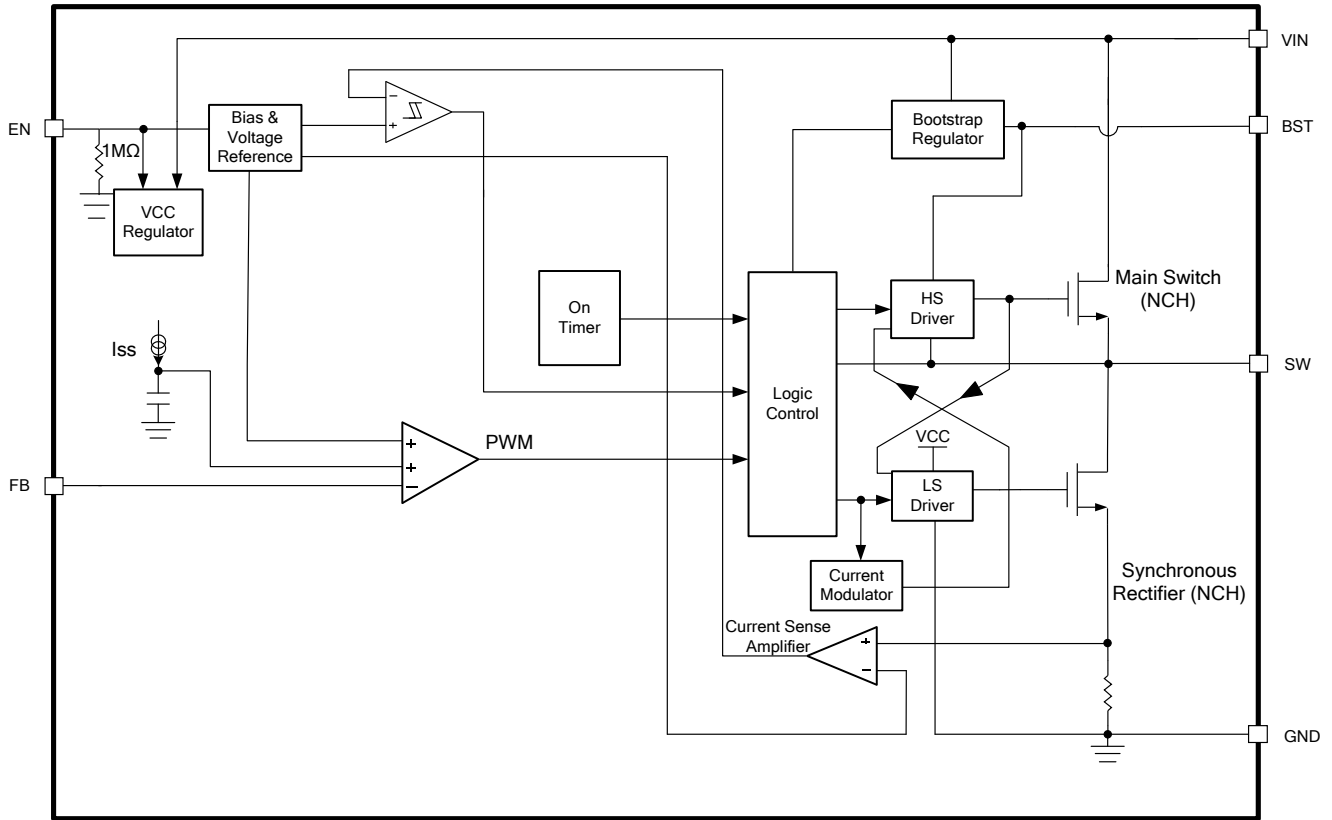

Figure 1: Functional Block Diagram

OPERATION

The MP1477H is a fully integrated, synchronous, rectified, step-down, switch mode converter. Constant-on-time (COT) control is employed to provide fast transient response and ease loop stabilization. At the beginning of each cycle, the high-side MOSFET (HS-FET) is turned on when the FB voltage (V_{FB}) drops below the reference voltage (V_{REF}). The HS-FET is turned on for a fixed interval determined by the one-shot on-timer. The on-timer is determined by both the output voltage and input voltage to make the switching frequency fairly constant over the input voltage range.

After the on period elapses, the HS-FET is turned off until the next period. By repeating operation this way, the converter regulates the output voltage.

The low-side MOSFET (LS-FET) is turned on when the HS-FET is in its off state to minimize conduction loss. There is a dead short between the input and GND if both the HS-FET and LS-FET are turned on at the same time. This is called shoot-through. To avoid shoot-through, a dead time is generated internally between the HS-FET off and LS-FET on period or the LS-FET off and HS-FET on period.

Enable Control (EN)

EN is a digital control pin that turns the regulator on and off. Drive EN high to turn on the regulator. Drive EN low to turn off the regulator. An internal $1M\Omega$ resistor from EN to GND allows EN to be floated to shut down the chip.

EN is clamped internally using a 2.8V series Zener diode (see Figure 2). Connecting the EN input through a pull-up resistor to VIN limits the EN input current below $100\mu A$ to prevent damaging the Zener diode. For example, when connecting 12V to VIN, $R_{PULLUP} \geq (12V - 2.8V) / (100k\Omega + 35k\Omega) = 68\mu A$.

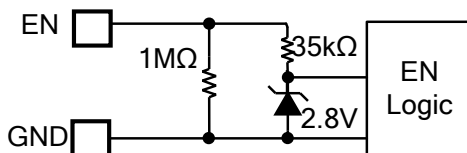

Figure 2: Zener Diode between EN and GND

Under-Voltage Lockout (UVLO)

Under-voltage lockout (UVLO) protects the chip from operating at an insufficient supply voltage. The MP1477H UVLO comparator monitors the output voltage of the internal regulator (VCC). The UVLO rising threshold is about 4V, while its falling threshold is 3.67V.

Internal Soft Start (SS)

Soft start prevents the converter output voltage from overshooting during start-up. When the chip starts up, the internal circuitry generates a soft-start voltage (SS) that ramps up from 0V to 1.2V. When SS is lower than REF, SS overrides REF so the error amplifier uses SS as the reference. When SS exceeds REF, the error amplifier uses REF as the reference. The SS time is set to 2.5ms internally.

Over-Current Protection (OCP) and Short-Circuit Protection (SCP)

The MP1477H has a valley current-limit control. During the LS-FET on state, the inductor current is monitored. When the sensed inductor current reaches the valley current limit, the low-side limit comparator turns over, the MP1477H enters over-current protection (OCP) mode, and the HS-FET waits until the valley current limit is removed before turning on again. Meanwhile, the output voltage drops until V_{FB} is below the under-voltage (UV) threshold (typically 44% below the reference). Once UV is triggered, the MP1477H enters hiccup mode to restart the part periodically.

During OCP, the device attempts to recover from the over-current fault with hiccup mode. In hiccup mode, the chip disables the output power stage, discharges the soft start, and attempts to soft start again automatically. If the over-current condition still remains after the soft start ends, the device repeats this operation cycle until the over-current condition is removed. The output rises back to the regulation level. OCP is a non-latch protection.

Pre-Bias Start-Up

The MP1477H is designed for monotonic start-up into pre-biased loads. If the output is pre-biased to a certain voltage during start-up, the BST voltage is refreshed and charged, and the voltage on the soft start is charged as well. If the BST voltage exceeds its rising threshold voltage and the soft-start voltage exceeds the sensed output voltage at FB, the MP1477H starts working normally.

Thermal Shutdown

Thermal shutdown prevents the chip from operating at exceedingly high temperatures. When the silicon die temperature exceeds 150°C, the entire chip shuts down. When the temperature falls below its lower threshold (typically 130°C), the chip is enabled again.

Floating Driver and Bootstrap Charging

An external bootstrap capacitor powers the floating power MOSFET driver. This floating driver has its own UVLO protection with a rising threshold of 2.2V and a hysteresis of 150mV. V_{IN} regulates the bootstrap capacitor voltage internally through D1, M1, C3, L1, and C2 (see Figure 3). If $V_{IN} - V_{SW}$ exceeds 3.3V, U2 regulates M1 to maintain a 3.3V BST voltage across C3.

Start-Up and Shutdown Circuit

If both V_{IN} and EN exceed their respective thresholds, the chip starts up. The reference block starts first, generating a stable reference voltage and current, and then the internal regulator is enabled. The regulator provides a stable supply for the remaining circuits.

Three events can shut down the chip: EN low, V_{IN} low, and thermal shutdown. The shutdown procedure starts by blocking the signaling path initially to avoid any fault triggering. The internal supply rail is then pulled down.

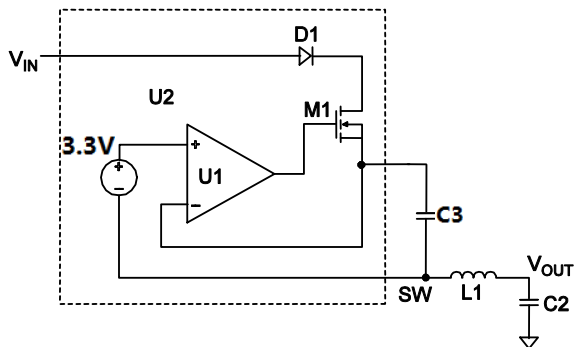

Figure 3: Internal Bootstrap Charger

APPLICATION INFORMATION

Setting the Output Voltage

The external resistor divider is used to set the output voltage. First, choose a value for R2. R2 should be chosen reasonably, since a small R2 leads to considerable quiescent current loss, while a large R2 makes FB noise-sensitive. R2 is recommended be within 5 - 100kΩ. Typically, set the current through R2 to be between 5 - 30μA for a good balance between system stability and no-load loss. Then determine R1 with Equation (2):

$$R1 = \frac{V_{OUT} - V_{REF}}{V_{REF}} \times R2 \quad (2)$$

The feedback circuit is shown in Figure 4.

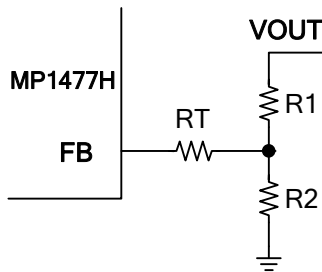

Figure 4: Feedback Network

Table 1 lists the recommended parameters for common output voltages.

Table 1: Parameter Selection for Common Output Voltages, C_{OUT} = 22μF*⁽⁹⁾

Vout (V)	R1 (kΩ)	R2 (kΩ)	RT (kΩ)	L (μH)
5	40.2	7.68	75	2.2
3.3	40.2	13	75	1.5
2.5	40.2	19.1	100	1.5
1.8	40.2	32.4	110	1.2
1.5	40.2	45.3	249	1
1.2	40.2	82	249	0.68
1	20.5	84.5	348	0.68

NOTE:

9) For the detail design circuit, please refer to the Typical Application Circuits on page 17 to 19.

Selecting the Inductor

An inductor is necessary for supplying constant current to the output load while being driven by the switched input voltage. A larger-value inductor results in less ripple current and a lower output ripple voltage but also has a larger physical footprint, higher series resistance, and

lower saturation current. A good rule for determining the inductance value is to design the peak-to-peak ripple current in the inductor to be in the range of 30 - 60% of the maximum output current. The inductance value can be calculated with Equation (3):

$$L = \frac{V_{OUT}}{F_{SW} \times \Delta I_L} \times \left(1 - \frac{V_{OUT}}{V_{IN}}\right) \quad (3)$$

Where Δ_L is the peak-to-peak inductor ripple current.

The inductor should not saturate under the maximum inductor peak current. The peak inductor current can be calculated with Equation (4):

$$I_{LP} = I_{OUT} + \frac{V_{OUT}}{2F_{SW} \times L} \times \left(1 - \frac{V_{OUT}}{V_{IN}}\right) \quad (4)$$

Selecting the Input Capacitor

The input current to the step-down converter is discontinuous and therefore requires a capacitor to supply AC current to the step-down converter while maintaining the DC input voltage. For best results, use ceramic capacitors placed as close to VIN as possible. Capacitors with X5R and X7R ceramic dielectrics are recommended because they are fairly stable with temperature fluctuations.

The capacitors must also have a ripple current rating greater than the maximum input ripple current of the converter. The input ripple current can be estimated with Equation (5):

$$I_{CIN} = I_{OUT} \times \sqrt{\frac{V_{OUT}}{V_{IN}} \times \left(1 - \frac{V_{OUT}}{V_{IN}}\right)} \quad (5)$$

The worst-case condition occurs at V_{IN} = 2V_{OUT}, shown in Equation (6):

$$I_{CIN} = \frac{I_{OUT}}{2} \quad (6)$$

For simplification, choose an input capacitor with an RMS current rating greater than half of the maximum load current.

The input capacitance value determines the input voltage ripple of the converter. If there is an input voltage ripple requirement in the system, choose an input capacitor that meets the specification.

The input voltage ripple can be estimated with Equation (7):

$$\Delta V_{IN} = \frac{I_{OUT}}{F_{SW} \times C_{IN}} \times \frac{V_{OUT}}{V_{IN}} \times \left(1 - \frac{V_{OUT}}{V_{IN}}\right) \quad (7)$$

The worst-case condition occurs at $V_{IN} = 2V_{OUT}$, shown in Equation (8):

$$\Delta V_{IN} = \frac{1}{4} \times \frac{I_{OUT}}{F_{SW} \times C_{IN}} \quad (8)$$

Selecting the Output Capacitor

An output capacitor is required to maintain the DC output voltage. Ceramic or POSCAP capacitors are recommended. The output voltage ripple can be estimated with Equation (9):

$$\Delta V_{OUT} = \frac{V_{OUT}}{F_{SW} \times L} \times \left(1 - \frac{V_{OUT}}{V_{IN}}\right) \times \left(R_{ESR} + \frac{1}{8 \times F_{SW} \times C_{OUT}}\right) \quad (9)$$

In the case of ceramic capacitors, the impedance at the switching frequency is dominated by the capacitance. The output voltage ripple is caused mainly by the capacitance. For simplification, the output voltage ripple can be estimated with Equation (10):

$$\Delta V_{OUT} = \frac{V_{OUT}}{8 \times F_{SW}^2 \times L \times C_{OUT}} \times \left(1 - \frac{V_{OUT}}{V_{IN}}\right) \quad (10)$$

The output voltage ripple caused by the ESR is very small.

In the case of POSCAP capacitors, the ESR dominates the impedance at the switching frequency. For simplification, the output ripple can be approximated with Equation (11):

$$\Delta V_{OUT} = \frac{V_{OUT}}{F_{SW} \times L} \times \left(1 - \frac{V_{OUT}}{V_{IN}}\right) \times R_{ESR} \quad (11)$$

A larger output capacitor can achieve a better load transient response, but consider the maximum output capacitor limitation in the design application. If the output capacitor value

is too high, the output voltage cannot reach the design value during the soft-start time and fails to regulate. The maximum output capacitor value (C_{O_max}) can be limited approximately with Equation (12):

$$C_{O_MAX} = (I_{LIM_AVG} - I_{OUT}) \times T_{SS} / V_{OUT} \quad (12)$$

Where I_{LIM_AVG} is the average start-up current during the soft-start period, and T_{SS} is the soft-start time.

PCB Layout Guidelines

Efficient layout of the switching power supplies is critical for stable operation. A poor layout design can result in poor line or load regulation and stability issues. For best results, refer to Figure 5 and follow the guidelines below.

1. Place the high-current paths (GND, VIN, and SW) very close to the device with short, direct, and wide traces.
2. Place the input capacitor as close to VIN and GND as possible (recommended within 1mm).
3. Place the external feedback resistors next to FB.
4. Keep the switching node SW short and away from the feedback network.

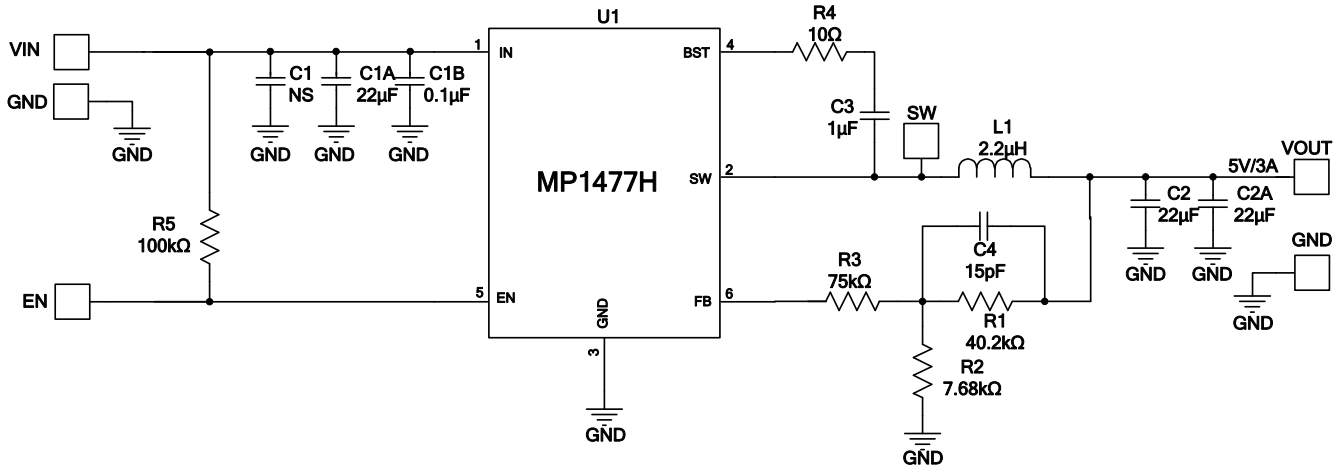
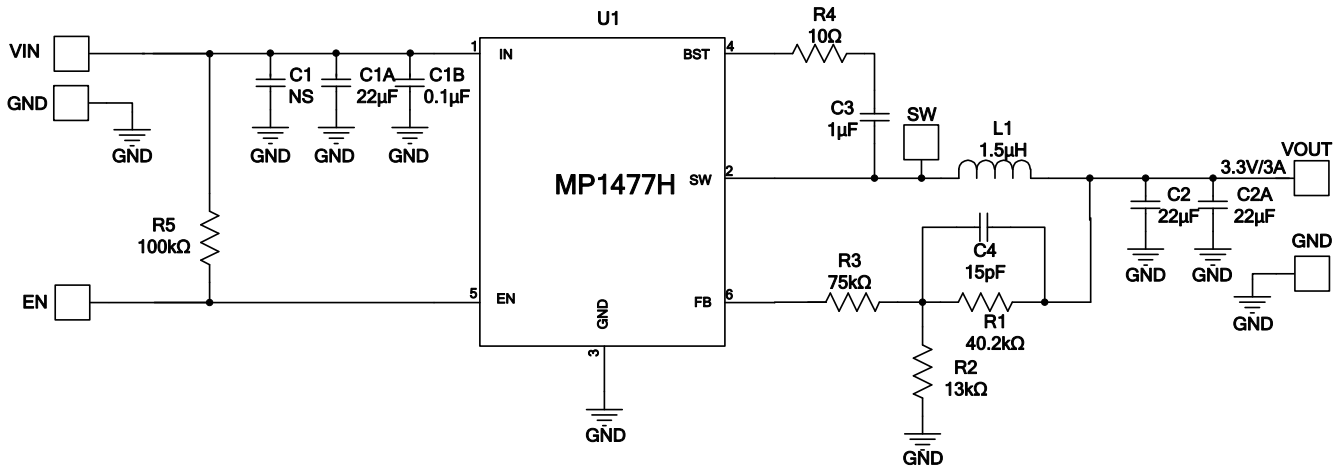
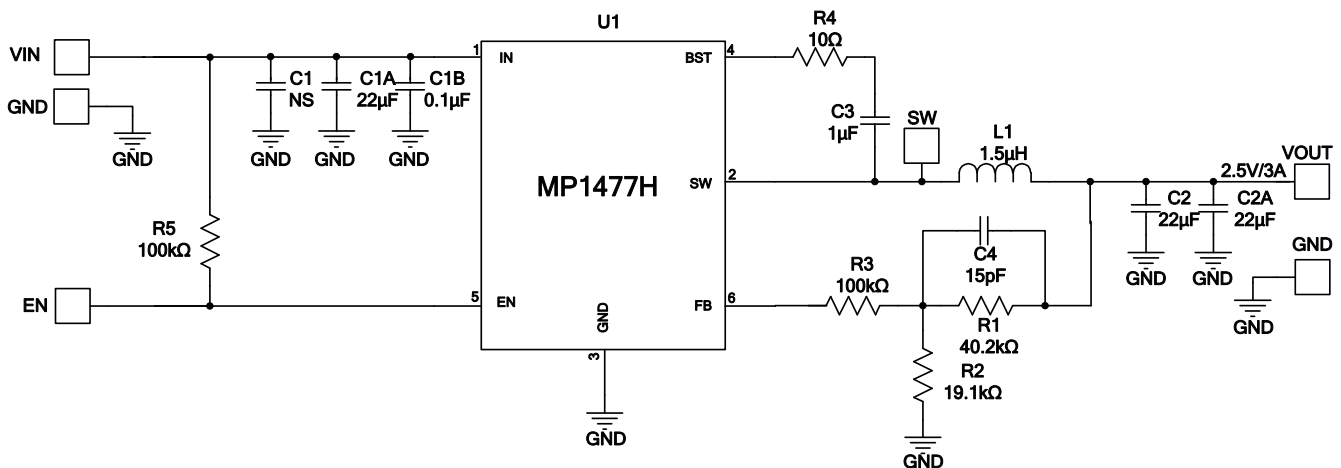
TYPICAL APPLICATION CIRCUITS

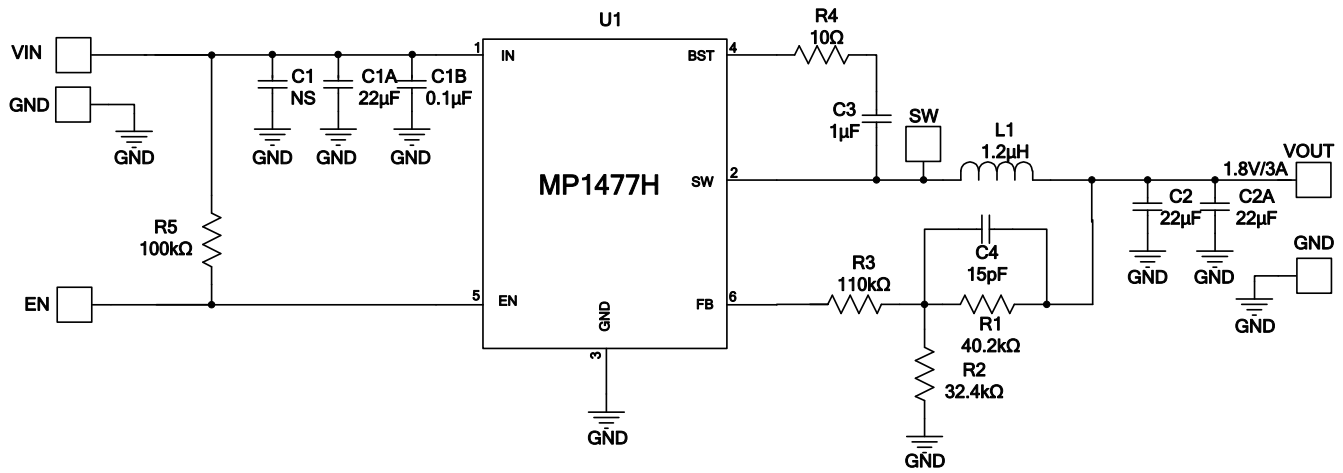
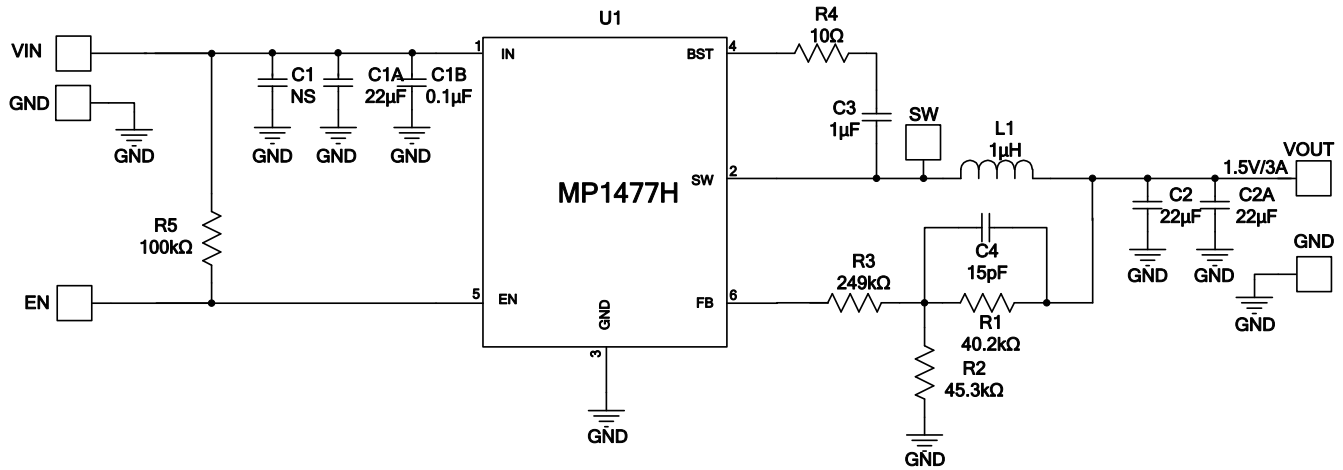
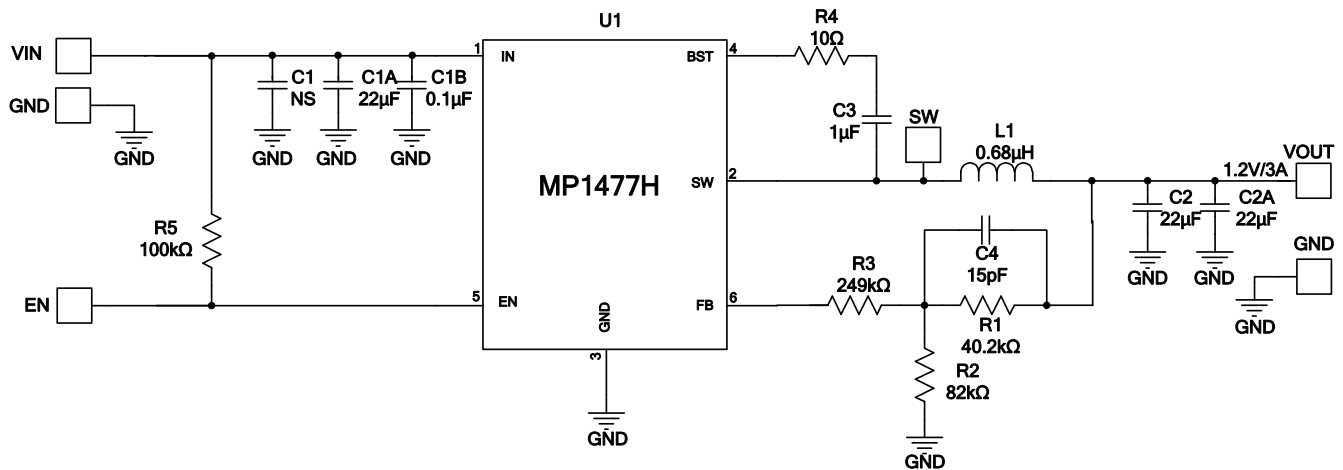
Figure 6: $V_{IN} = 12V$, $V_{OUT} = 5V/3A$

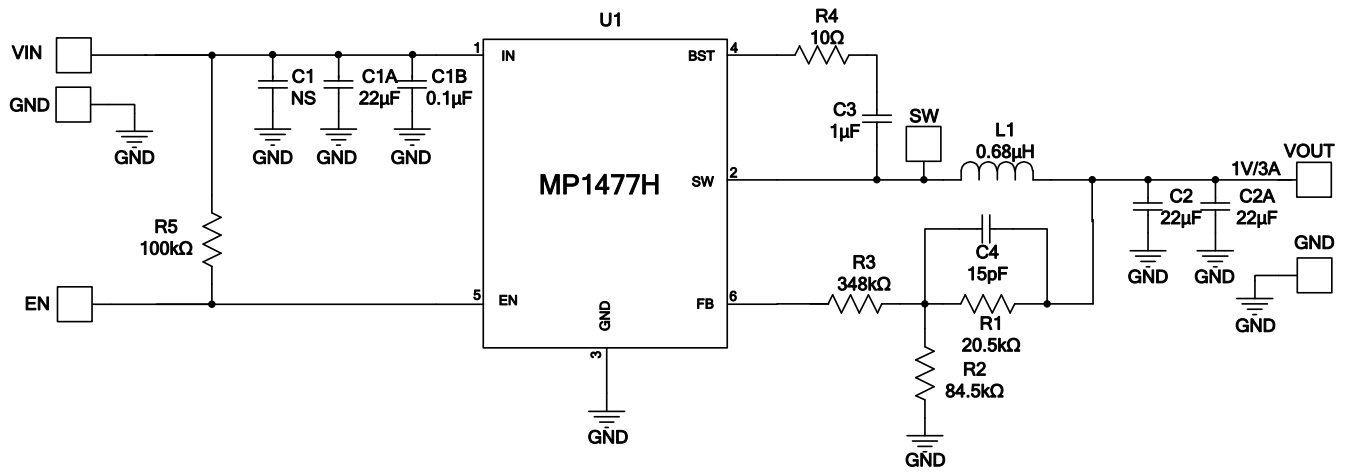
Figure 7: $V_{IN} = 12V$, $V_{OUT} = 3.3V/3A$

Figure 8: $V_{IN} = 12V$, $V_{OUT} = 2.5V/3A$

TYPICAL APPLICATION CIRCUITS (continued)

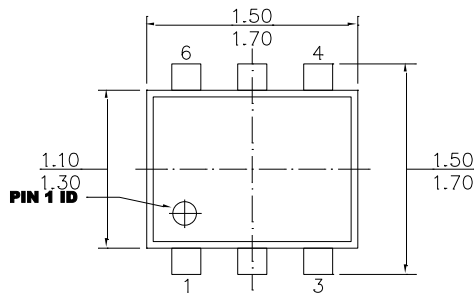
Figure 9: $V_{IN} = 12V$, $V_{OUT} = 1.8V/3A$

Figure 10: $V_{IN} = 12V$, $V_{OUT} = 1.5V/3A$

Figure 11: $V_{IN} = 12V$, $V_{OUT} = 1.2V/3A$

TYPICAL APPLICATION CIRCUITS (continued)

Figure 12: $V_{IN} = 12V$, $V_{OUT} = 1V/3A$

PACKAGE INFORMATION

SOT563 (1.6mmx1.6mm)

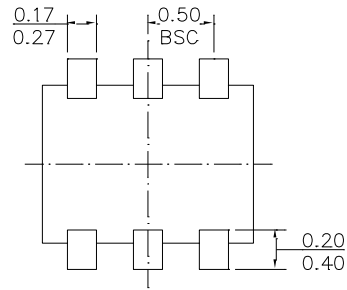

TOP VIEW



BOTTOM VIEW



FRONT VIEW

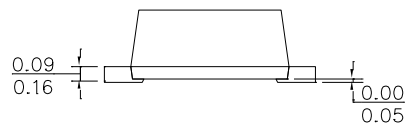

SIDE VIEW

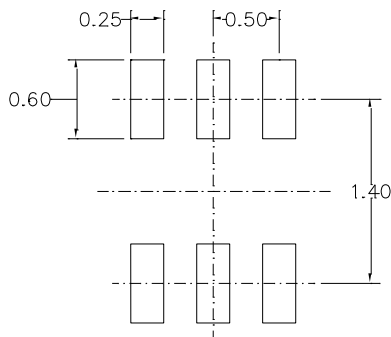

RECOMMENDED LAND PATTERN

NOTE:

- 1) ALL DIMENSIONS ARE IN MILLIMETERS.
- 2) PACKAGE LENGTH DOES NOT INCLUDE MOLD FLASH, PROTRUSION OR GATE BURR.
- 3) PACKAGE WIDTH DOES NOT INCLUDE INTERLEAD FLASH OR PROTRUSION.
- 4) LEAD COPLANARITY (BOTTOM OF LEADS AFTER FORMING) SHALL BE 0.10 MILLIMETERS MAX.
- 5) DRAWING IS NOT TO SCALE.

NOTICE: The information in this document is subject to change without notice. Users should warrant and guarantee that third party Intellectual Property rights are not infringed upon when integrating MPS products into any application. MPS will not assume any legal responsibility for any said applications.

X-ON Electronics

Largest Supplier of Electrical and Electronic Components

Click to view similar products for [Switching Voltage Regulators](#) category:

Click to view products by [Monolithic Power Systems](#) manufacturer:

Other Similar products are found below :

[FAN53610AUC33X](#) [FAN53611AUC123X](#) [FAN48610BUC33X](#) [FAN48610BUC45X](#) [FAN48617UC50X](#) [R3](#) [430464BB](#) [KE177614](#)
[MAX809TTR](#) [NCV891234MW50R2G](#) [NCP81103MNTXG](#) [NCP81203PMNTXG](#) [NCP81208MNTXG](#) [NCP81109GMNTXG](#)
[SCY1751FCCT1G](#) [NCP81109JMNTXG](#) [AP3409ADNTR-G1](#) [NCP81241MNTXG](#) [LTM8064IY](#) [LT8315EFE#TRPBF](#) [NCV1077CSTBT3G](#)
[XCL207A123CR-G](#) [MPM54304GMN-0002](#) [MPM54304GMN-0003](#) [XDPE132G5CG000XUMA1](#) [DA9121-B0V76](#) [MP8757GL-P](#)
[MIC23356YFT-TR](#) [LD8116CGL](#) [HG2269M/TR](#) [OB2269](#) [XD3526](#) [U6215A](#) [U6215B](#) [U6620S](#) [LTC3803ES6#TR](#) [LTC3803ES6#TRM](#)
[LTC3412IFE](#) [LT1425IS](#) [MAX25203BATJA/VY+](#) [MAX77874CEWM+](#) [XC9236D08CER-G](#) [ISL95338IRTZ](#) [MP3416GJ-P](#) [BD9S201NUX-](#)
[CE2](#) [MP5461GC-Z](#) [MPQ4415AGQB-Z](#) [MPQ4590GS-Z](#) [MCP1603-330IMC](#) [MCP1642B-18IMC](#)