

## DESCRIPTION

The MP2136 is a 2MHz constant frequency, current mode, PWM step-down converter with integrated main switch and synchronous rectifier that is ideal for powering portable equipment that runs from a single Li-Ion or Li-Polymer battery.

The MP2136 can supply up to 1A load current from a 2.5V to 6V input voltage. The output voltage can be as low as 0.6V.

Additional features include <math><1\mu\text{A}</math> shutdown current, internal soft-start, cycle-by-cycle over current protection, short circuit protection, and thermal shutdown.

The MP2136 is available in a 6-pin, QFN6 2mm $\times$ 2mm package.

## FEATURES

- 2MHz Constant Switching Frequency
- 1A Available Load Current
- 2.5V to 6V Input Voltage Range
- Output Voltage as Low as 0.6V
- Current Mode Control
- Cycle-by-Cycle Over Current Protection
- Short Circuit Protection
- Thermal Shutdown
- <math><1\mu\text{A}</math> Shutdown Current
- Internal Soft-Start
- Space-Saving 6-pin, QFN6 2mm $\times$ 2mm package

## APPLICATIONS

- Cellular Phones
- Microprocessors and DSP Core Supplies
- PDAs and Smart Phones
- MP3 and Portable Media Players
- Digital Still and Video Cameras
- Portable Instruments

"MPS" and "The Future of Analog IC Technology" are Registered Trademarks of Monolithic Power Systems, Inc.

## TYPICAL APPLICATION

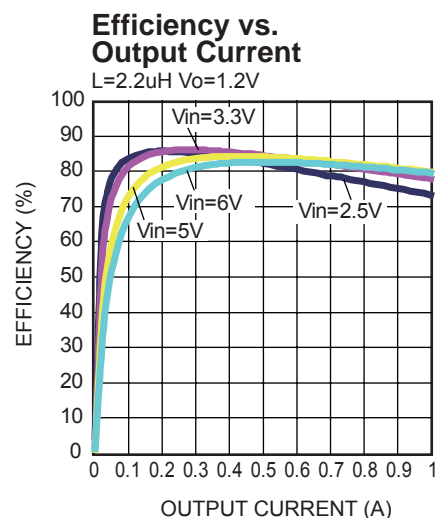
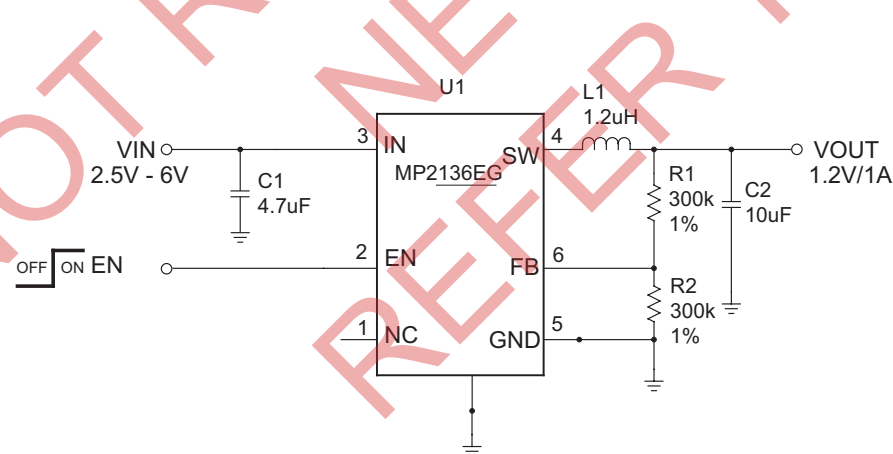

**ORDERING INFORMATION**

Part Number*	Package	Top Marking	Free Air Temperature(T <sub>A</sub> )
MP2136EG	QFN6 (2mmx2mm)	6Q	-20°C to +85°C

\* For Tape & Reel, add suffix -Z (eg. MP2136EG-Z).  
 For RoHS Compliant Packaging, add suffix -LF (eg. MP2136EG-LF-Z)

**PACKAGE REFERENCE**

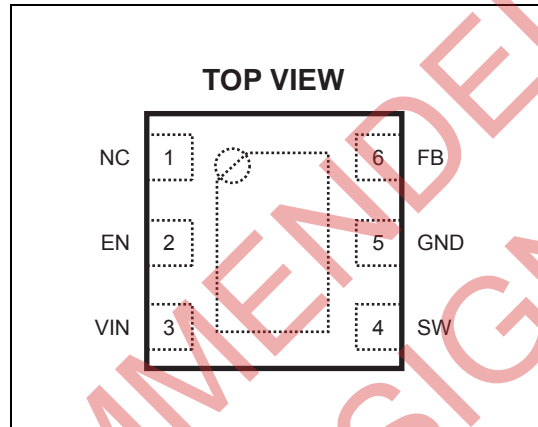

**ABSOLUTE MAXIMUM RATINGS (1)**

IN to GND	-0.3V to +6.5V
SW to GND	-0.3V to V <sub>IN</sub> + 0.3V
FB, EN to GND	-0.3V to +6.5V
Continuous Power Dissipation. (T <sub>A</sub> = +25°C) (2)	
QFN6 (2mmx2mm)	2.5W
Junction Temperature	150°C
Lead Temperature	260°C
Storage Temperature	-65°C to +150°C

**Recommended Operating Conditions (3)**

Supply Voltage V <sub>IN</sub>	2.5V to 6V
Output Voltage V <sub>OUT</sub>	0.6V to 6V
Operating Junct.Temp. (T <sub>J</sub> )	-20°C to +125°C

Thermal Resistance (4)	θ <sub>JA</sub>	θ <sub>JC</sub>
QFN6 (2mmx2mm)	50	12... °C/W

**Notes:**

- 1) Exceeding these ratings may damage the device.
- 2) The maximum allowable power dissipation is a function of the maximum junction temperature T<sub>J</sub> (MAX), the junction-to-ambient thermal resistance θ<sub>JA</sub>, and the ambient temperature T<sub>A</sub>. The maximum allowable continuous power dissipation at any ambient temperature is calculated by P<sub>D</sub> (MAX) = (T<sub>J</sub> (MAX)-T<sub>A</sub>)/θ<sub>JA</sub>. Exceeding the maximum allowable power dissipation will cause excessive die temperature, and the regulator will go into thermal shutdown. Internal thermal shutdown circuitry protects the device from permanent damage.
- 3) The device is not guaranteed to function outside of its operating conditions.
- 4) Measured on JESD51-7, 4-layer PCB.

**ELECTRICAL CHARACTERISTICS** <sup>(5)</sup>
 $V_{IN} = V_{EN} = 3.6V$ ,  $T_A = +25^{\circ}C$ , unless otherwise noted.

Parameters	Condition	Min	Typ	Max	Units
Supply Current	$V_{EN} = V_{IN}$ , $V_{FB} = 0.65V$		350		$\mu A$
Shutdown Current	$V_{EN} = 0V$ , $V_{IN} = 6V$		0.01	1	$\mu A$
IN Under Voltage Lockout Threshold	Rising Edge	1.8	2.1	2.3	V
IN Under Voltage Lockout Hysteresis			250		mV
Regulated FB Voltage	$T_A = +25^{\circ}C$	0.582	0.594	0.606	V
	$-40^{\circ}C \leq T_A \leq +85^{\circ}C$	0.576	0.594	0.612	V
FB Input Bias Current	$V_{FB} = 0.65V$	-50		50	nA
PFET Current Limit	Duty=100%		1.5		A
PFET On-Resistance	$I_{SW} = 100mA$		200		m $\Omega$
NFET On-Resistance	$I_{SW} = -100mA$		150		m $\Omega$
SW Leakage Current	$V_{EN} = 0V$ ; $V_{IN} = 6V$ $V_{SW} = 0V$ or $6V$	-1		1	$\mu A$
EN High Threshold	$-40^{\circ}C \leq T_A \leq +85^{\circ}C$	1.6			V
EN Low Threshold	$-40^{\circ}C \leq T_A \leq +85^{\circ}C$			0.4	V
Internal Soft-Start Time			150		$\mu s$
Oscillator Frequency			2		MHz
Thermal Shutdown Threshold	Hysteresis=20 $^{\circ}C$		150		$^{\circ}C$
			20		$^{\circ}C$

**Note:**

 5) Production test at +25 $^{\circ}C$ . Specifications over the temperature range are guaranteed by design and characterization.

**TYPICAL PERFORMANCE CHARACTERISTICS**

$V_{OUT}=1.2V$ ,  $L=1.2\mu H$ ,  $C2=10\mu F$ ,  $T_A=25^\circ C$ , unless otherwise noted.

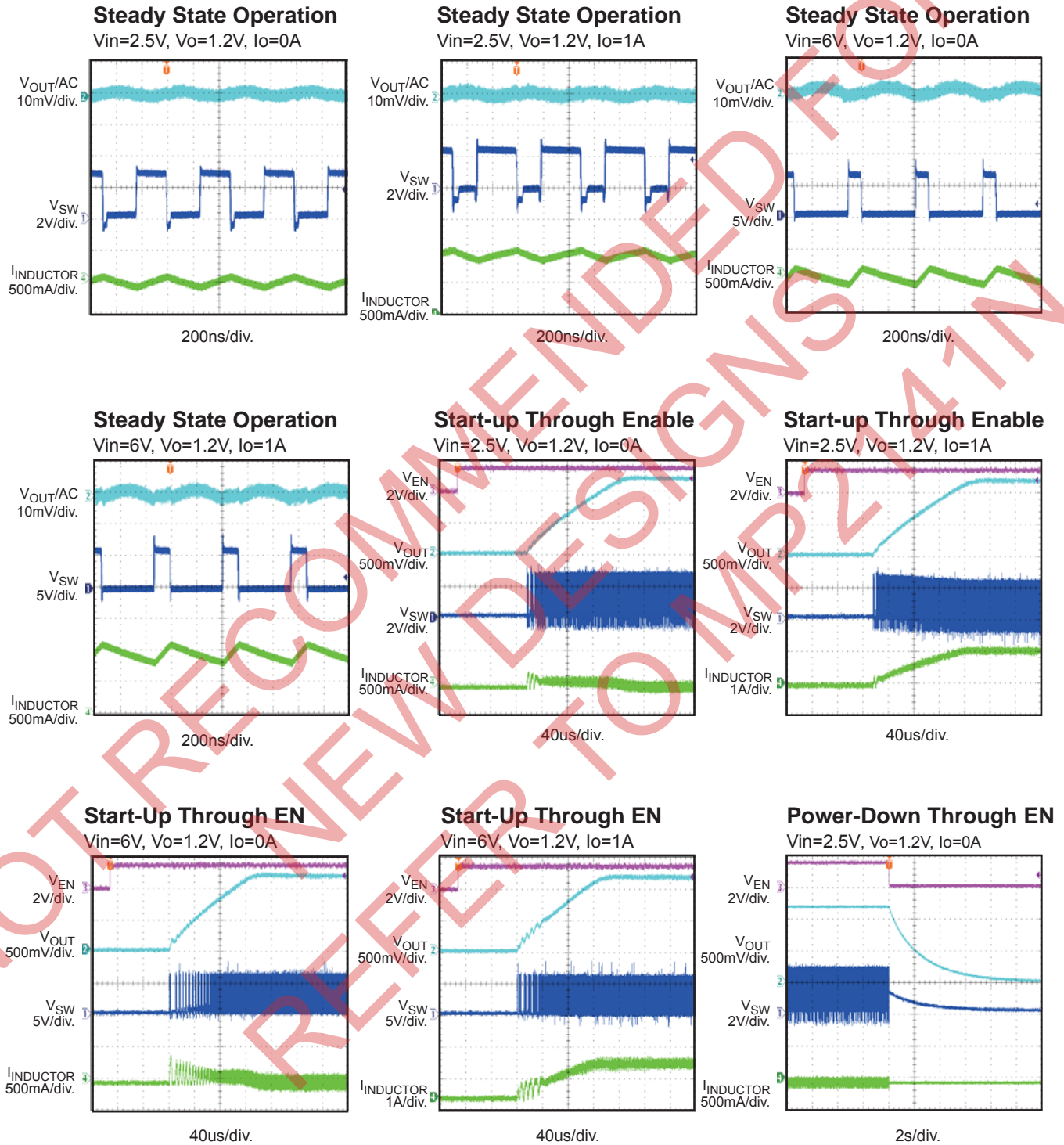

**TYPICAL PERFORMANCE CHARACTERISTICS** (continued)

$V_{OUT}=1.2V$ ,  $L=1.2\mu H$ ,  $C2=10\mu F$ ,  $T_A=25^\circ C$ , unless otherwise noted.

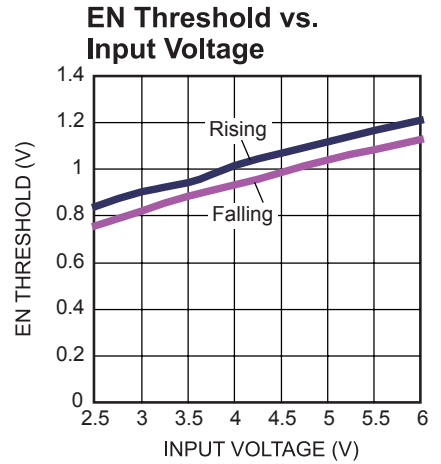
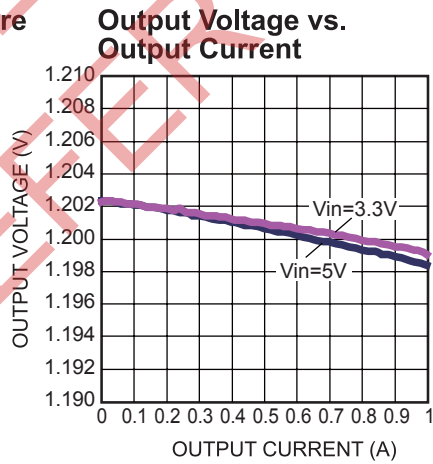
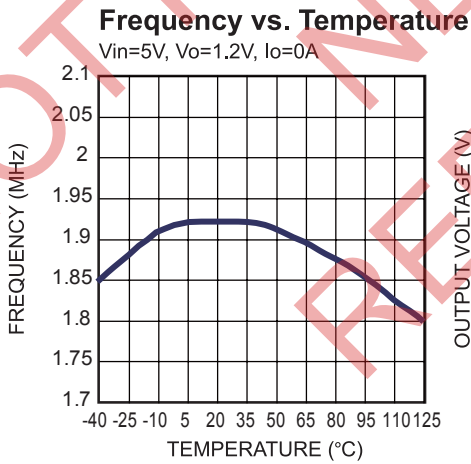
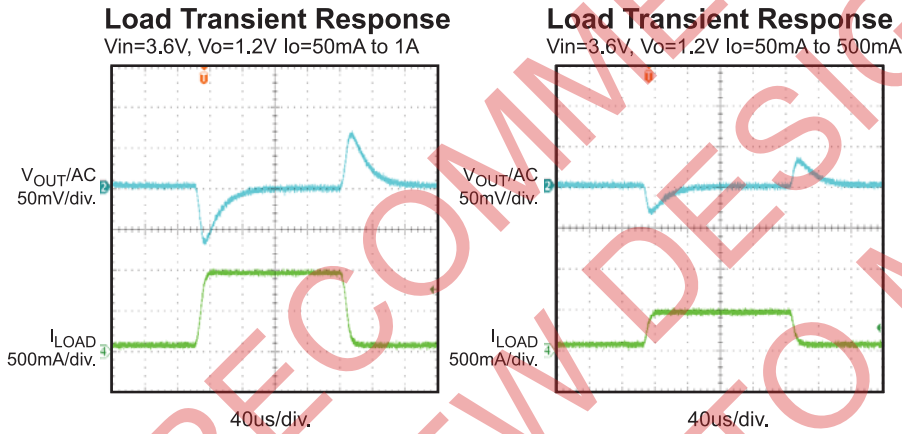
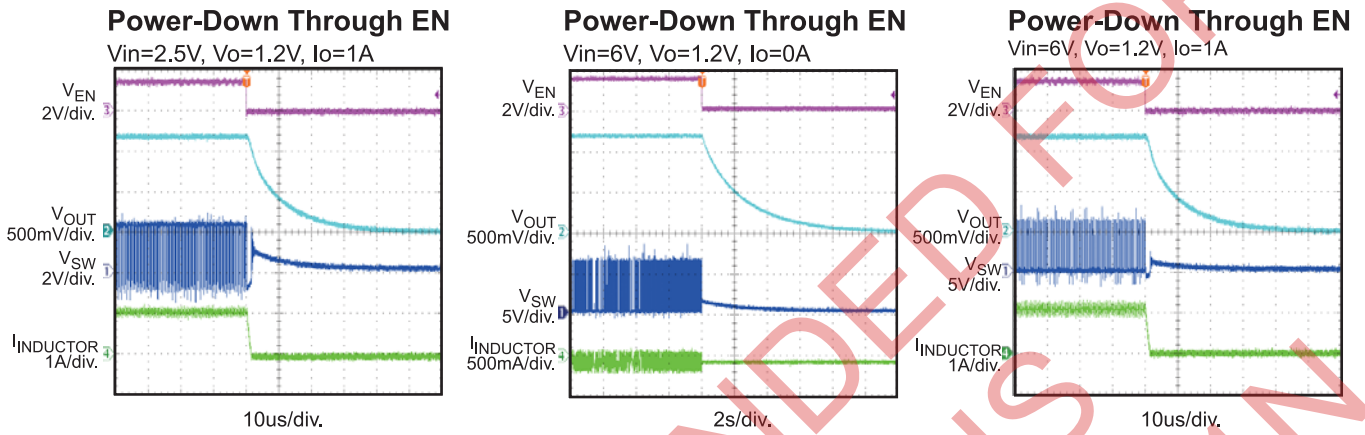

**PIN FUNCTIONS**

Pin #	Name	Description
1	NC	No connection. Leave Pin1 disconnection.
2	EN	Regulator Enable Control Input. Drive EN above 1.6V to turn on the part. Drive EN below 0.4V to turn it off.
3	IN	Supply Input. Bypass to GND with a 4.7 $\mu$ F or bigger value ceramic capacitor.
4	SW	Power Switch Output. Inductor connection to drains of the internal PFET and NFET switches.
5	GND, Exposed Pad	Ground. Connect exposed pad to ground plane for optimal thermal performance.
6	FB	Feedback Input. Connect FB to the center point of the external resistor divider. The regulated feedback voltage is 0.6V.

**FUNCTIONAL BLOCK DIAGRAM**

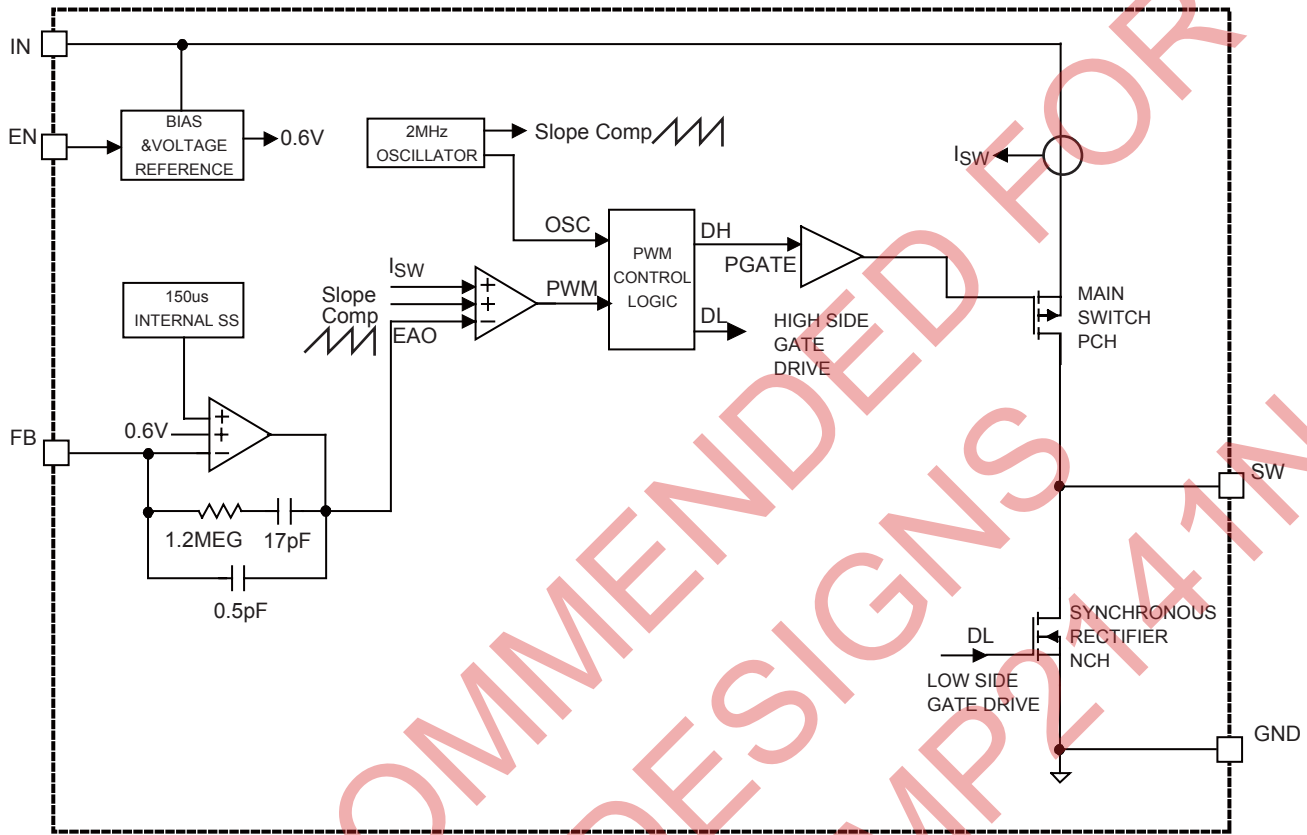

Figure 1— Functional Block Diagram



## FUNCTIONAL DESCRIPTION

MP2136 is a 2MHz constant frequency, current mode, PWM step-down converter. The device integrates both a main switch and a synchronous rectifier, which provides high efficiency and eliminates an external Schottky diode. It is ideal for powering portable equipment that runs from a single Li-Ion or Li-Polymer battery.

The MP2136 can achieve 100% duty cycle. The duty cycle D of a step-down converter is defined as:

$$D = T_{ON} \times f_{OSC} \times 100\% \approx \frac{V_{OUT}}{V_{IN}} \times 100\%$$

Where,

T<sub>on</sub>: Main Switch ON time

f<sub>osc</sub>: Switching frequency (2MHz)

V<sub>out</sub>: Output voltage

V<sub>in</sub>: Input voltage

### Peak Current Mode PWM Control

Slope compensated current mode PWM control provides stable switching and cycle-by-cycle current limit for superior load and line response and protection of the internal main switch and synchronous rectifier. The MP2136 switches at a constant frequency (2MHz) and regulates the output voltage. During each cycle the PWM comparator modulates the power transferred to the load by changing the inductor peak current based on the feedback error voltage.

During normal operation, the main switch is turned on for a certain time to ramp the inductor current at each rising edge of the internal oscillator, and switched off when the peak inductor current is above the error voltage.

When the main switch is off, the synchronous rectifier will be turned on immediately and stay on until the next cycle starts.

### Dropout Operation

The MP2136 allows the main switch to remain on for more than one switching cycle and increases the duty cycle while the input voltage is dropping close to the output voltage. When the duty cycle reaches 100%, the main switch is held on continuously to deliver current to the output up to the PFET current limit. The output voltage then is the input voltage minus the voltage drop across the main switch and the inductor.

### Short Circuit Protection

The MP2136 has short circuit protection. When the output is shorted to ground, the oscillator frequency is reduced to prevent the inductor current from increasing beyond the PFET current limit. The PFET current limit is also reduced to lower the short-circuit current. The frequency and current limit will return to the normal values once the short circuit condition is removed and the feedback voltage reaches 0.6V.

### Maximum Load current

The MP2136 can operate down to 2.5V input voltage, however the maximum load current decreases at lower input due to large IR drop on the main switch and synchronous rectifier. The slope compensation signal reduces the peak inductor current as a function of the duty cycle to prevent sub-harmonic oscillations at duty cycles greater than 50%. Conversely the current limit increases as the duty cycle decreases.



## APPLICATION INFORMATION

### Output Voltage Setting

The external resistor divider sets the output voltage. The feedback resistor R1 also sets the feedback loop bandwidth with the internal compensation capacitor.

Choose R1 around 300kΩ for optimal transient response. R2 is then given by:

$$R2 = \frac{R1}{\frac{V_{OUT}}{0.6V} - 1}$$

**Table 1—Resistor Selection vs. Output Voltage Setting**

V <sub>OUT</sub>	R1	R2
1.2V	300kΩ (1%)	300kΩ (1%)
1.5V	300kΩ (1%)	200kΩ (1%)
1.8V	300kΩ (1%)	150kΩ (1%)
2.5V	300kΩ (1%)	95.3kΩ (1%)

### Inductor Selection

A 0.68μH to 10μH inductor with DC current rating at least 25% higher than the maximum load current is recommended for most applications. For best efficiency, the inductor DC resistance shall be <200mΩ. For most designs, the inductance value can be derived from the following equation:

$$L = \frac{V_{OUT} \times (V_{IN} - V_{OUT})}{V_{IN} \times \Delta I_L \times f_{OSC}}$$

Where ΔI<sub>L</sub> is the inductor ripple current. Choose inductor ripple current approximately 30% of the maximum load current, 1A.

The maximum inductor peak current is:

$$I_{L(MAX)} = I_{LOAD} + \frac{\Delta I_L}{2}$$

Under light load conditions below 100mA, larger inductance is recommended for improved efficiency.

### Input Capacitor Selection

The input capacitor reduces the surge current drawn from the input and switching noise from the device. The input capacitor impedance at the switching frequency shall be less than input source impedance to prevent high frequency switching current passing to the input. Ceramic capacitors with X5R or X7R dielectrics are highly recommended because of their low ESR and small temperature coefficients. The input capacitor absorbs the input switching current, so it requires an adequate ripple current rating. The RMS current through the input capacitor can be estimated by:

$$I_{CIN} = I_{LOAD} \times \sqrt{\frac{V_{OUT}}{V_{IN}} \times \left(1 - \frac{V_{OUT}}{V_{IN}}\right)}$$

The worse case condition occurs at V<sub>IN</sub>=2V<sub>OUT</sub>, where:

$$I_{CIN} = \frac{I_{LOAD}}{2}$$

For simplification, choose the input capacitor whose RMS current rating greater than half of the maximum load current.

For most applications, a 4.7μF capacitor is sufficient.

### Output Capacitor Selection

The output capacitor keeps output voltage ripple small and ensures regulation loop stable. The output capacitor impedance shall be low at the switching frequency. Ceramic capacitors with X5R or X7R dielectrics are recommended. The output ripple ΔV<sub>OUT</sub> is approximately:

$$\Delta V_{OUT} \leq \frac{V_{OUT} \times (V_{IN} - V_{OUT})}{V_{IN} \times f_{OSC} \times L} \times \left( ESR + \frac{1}{8 \times f_{OSC} \times C3} \right)$$

For most applications, a 10uF capacitor is sufficient.

## PCB LAYOUT GUIDE

PCB layout is very important to achieve stable operation. It is highly recommended to duplicate EVB layout for optimum performance.

If change is necessary, please follow these guidelines and take Figure 2 for reference.

- 1) Keep the path of switching current short and minimize the loop area formed by Input cap, high-side MOSFET and low-side MOSFET.
- 2) Bypass ceramic capacitors are suggested to be put close to the  $V_{IN}$  Pin.
- 2) Ensure all feedback connections are short and direct. Place the feedback resistors as close to the chip as possible.
- 4) Route SW away from sensitive analog areas such as FB.
- 5) Connect IN, SW, and especially GND respectively to a large copper area to cool the chip to improve thermal performance and long-term reliability.

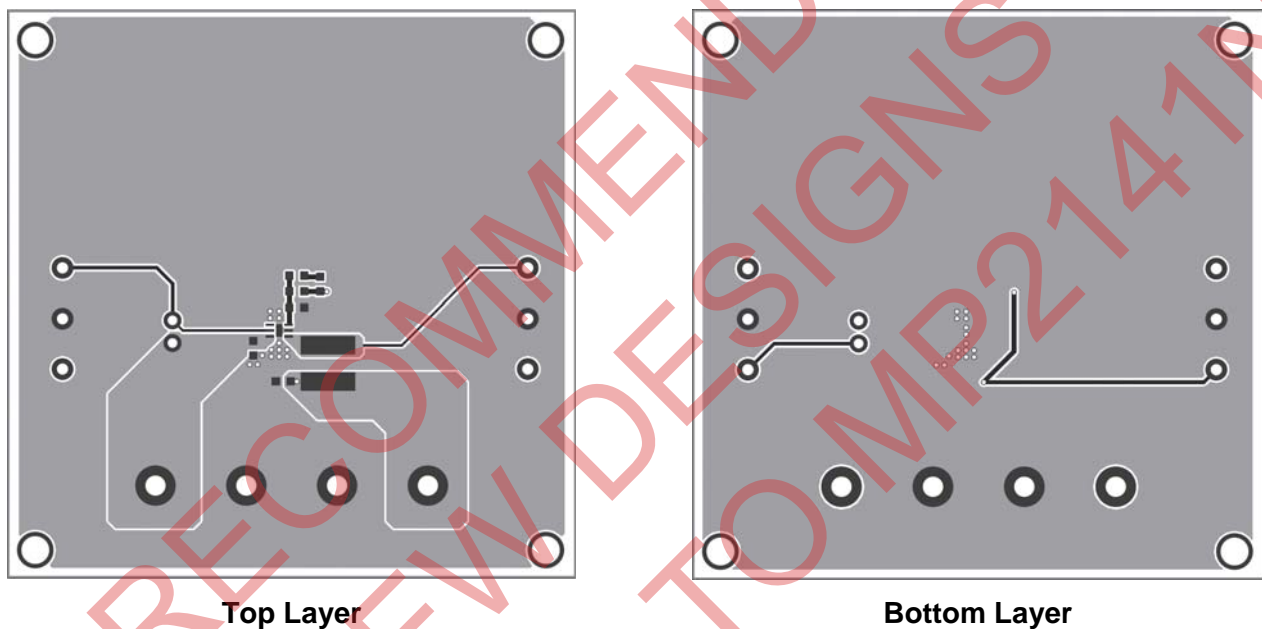
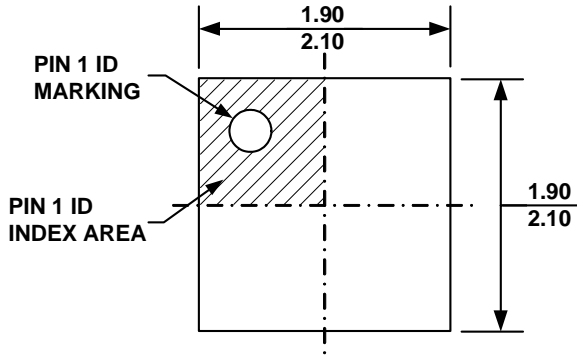

Figure 2—MP2136 Suggested Layout

**PACKAGE INFORMATION**

**QFN6 (2mmX2mm)**



**TOP VIEW**

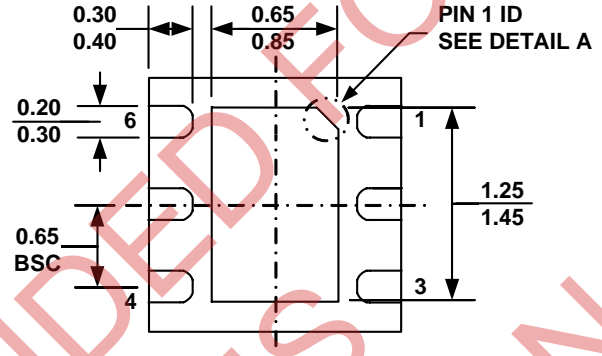

**BOTTOM VIEW**

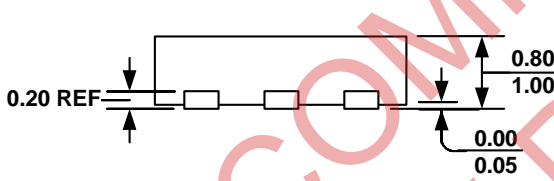

**SIDE VIEW**

**PIN 1 ID OPTION A**  
0.30x45° TYP.

**PIN 1 ID OPTION B**  
R0.20 TYP.



**DETAIL A**

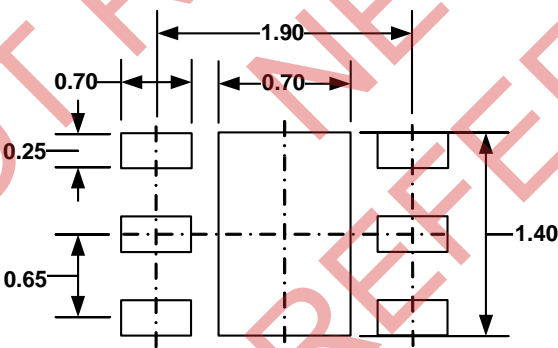

**RECOMMENDED LAND PATTERN**

**NOTICE:** The information in this document is subject to change without notice. Users should warrant and guarantee that third party Intellectual Property rights are not infringed upon when integrating MPS products into any application. MPS will not assume any legal responsibility for any said applications.

## X-ON Electronics

Largest Supplier of Electrical and Electronic Components

*Click to view similar products for [Switching Voltage Regulators](#) category:*

*Click to view products by [Monolithic Power Systems](#) manufacturer:*

Other Similar products are found below :

[FAN53610AUC33X](#) [FAN53611AUC123X](#) [FAN48610BUC33X](#) [FAN48610BUC45X](#) [FAN48617UC50X](#) [R3](#) [430464BB](#) [KE177614](#)  
[MAX809TTR](#) [NCV891234MW50R2G](#) [NCP81103MNTXG](#) [NCP81203PMNTXG](#) [NCP81208MNTXG](#) [NCP81109GMNTXG](#)  
[SCY1751FCCT1G](#) [NCP81109JMNTXG](#) [AP3409ADNTR-G1](#) [NCP81241MNTXG](#) [LTM8064IY](#) [LT8315EFE#TRPBF](#) [NCV1077CSTBT3G](#)  
[XCL207A123CR-G](#) [MPM54304GMN-0002](#) [MPM54304GMN-0003](#) [XDPE132G5CG000XUMA1](#) [DA9121-B0V76](#) [MP8757GL-P](#)  
[MIC23356YFT-TR](#) [LD8116CGL](#) [HG2269M/TR](#) [OB2269](#) [XD3526](#) [U6215A](#) [U6215B](#) [U6620S](#) [LTC3803ES6#TR](#) [LTC3803ES6#TRM](#)  
[LTC3412IFE](#) [LT1425IS](#) [MAX25203BATJA/VY+](#) [MAX77874CEWM+](#) [XC9236D08CER-G](#) [ISL95338IRTZ](#) [MP3416GJ-P](#) [BD9S201NUX-CE2](#) [MP5461GC-Z](#) [MPQ4415AGQB-Z](#) [MPQ4590GS-Z](#) [MCP1603-330IMC](#) [MCP1642B-18IMC](#)