



### DESCRIPTION

The MP2667 is a highly integrated, single-cell, Li-ion/Li-polymer battery charger with system power path management for space-limited portable applications. The MP2667 takes input power from either an AC adapter or a USB port to supply the system load and charge the battery simultaneously. The charger function features constant current pre-charge, constant current fast charge (CC) and constant voltage (CV) regulation, charge termination, and auto-recharge.

The power path management function ensures continuous power to the system by automatically selecting the input, battery, or both to power the system. This power stage features a low-dropout regulator from the input to the system and a 100mΩ switch from the battery to the system. Power path management separates the charging current from the system load, which allows for proper charge termination and keeps the battery in full-charge mode.

The MP2667 provides a system short-circuit protection (SCP) function by limiting the current from the input to the system and the battery to the system. This feature is especially critical for preventing the Li-ion battery from being damaged due to excessively high currents. An on-chip battery under-voltage lockout (UVLO) cuts off the path between the battery and the system if the battery voltage drops below the programmable battery UVLO threshold. This prevents the Li-ion battery from being over-discharged. An integrated I<sup>2</sup>C control interface allows the MP2667 to program the charging parameters, such as the input current limit, input minimum voltage regulation, charging current, battery regulation voltage, safety timer, and battery UVLO.

The MP2667 is available in a 10-pin QFN (2mmx2mm) package.

### FEATURES

- Compatible with 5V USB Power Sources
- Fully Autonomous Charger for Single-Cell Li-Ion/Li-Polymer Batteries
- Complete Power Path Management for Simultaneously Powering the System and Charging the Battery
- Programmable Input Current Limit and Minimum Input Voltage Regulation Thresholds
- ±0.5% Charging Voltage Accuracy
- 13V Maximum Voltage for the Input Source
- I<sup>2</sup>C Interface for Programming Charging Parameters and Status Reporting
- Fully Integrated Power Switches and No External Blocking Diode Required
- Built-In Robust Charging Protection Including Battery Temperature Monitoring and Programmable Timer
- Built-In Battery Disconnection Function for Shipping Mode
- Thermal Limiting Regulation on the Chip
- Available in an Ultra-Compact QFN-10 (2mmx2mm) Package

### APPLICATIONS

- Wearable Devices
- Smart Handheld Devices
- Fitness Accessories
- Smartwatches
- Bluetooth Headphones

All MPS parts are lead-free, halogen-free, and adhere to the RoHS directive. For MPS green status, please visit the MPS website under Quality Assurance. "MPS", the MPS logo, and "Simple, Easy Solutions" are registered trademarks of Monolithic Power Systems, Inc. or its subsidiaries.

## TYPICAL APPLICATION

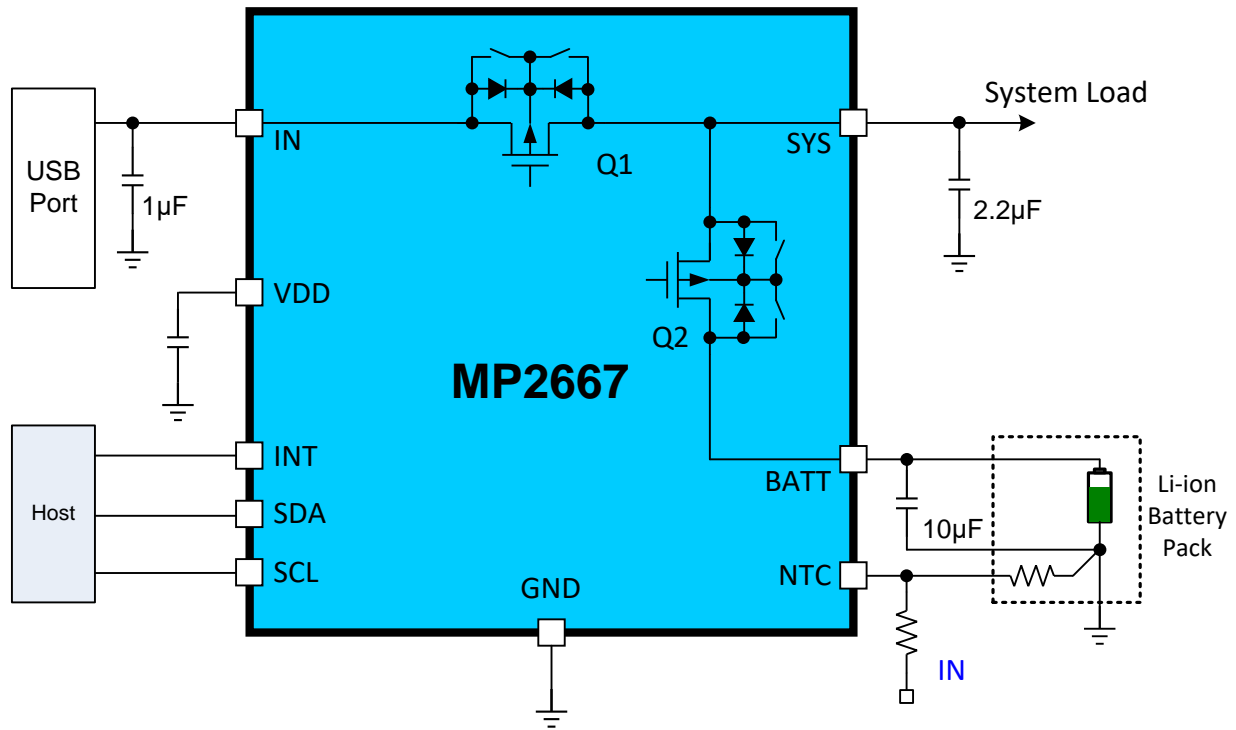

Table 1: Operation Mode Table

FET On/Off Change By Control	I <sup>2</sup> C Control		
	HZ = 1	CEB = 1	FET_DIS = 1*
	Enter Hi-Z Mode	Charge Control	Enter Shipping Mode
LDO FET	Off	x	x
Battery FET (charging)	x	Off	Off
Battery FET (discharging)	x	x	Off

x = N/A

\* FET\_DIS goes back to 0 when the battery FET is off.

### ORDERING INFORMATION

Part Number*	Package	Top Marking
MP2667GG-xxxx**	QFN-10 (2mmx2mm)	See Below
EVKT-MP2667	Evaluation kit	See Below

\* For Tape & Reel, add suffix -Z (e.g. MP2667GG-xxxx-Z).

\*\* “xxxx” is the configuration code identifier for the register settings. For the default case, the number is “0000.” Each “x” can have a hexadecimal value between 0 and F. Contact an MPS FAE to create this unique number, even if ordering the “0000” code.

### TOP MARKING

—  
JQY  
LLL

JQ: Product code of MP2667GG

Y: Year code

LLL: Lot number

### EVALUATION KIT EVKT-MP2667

EVKT-MP2667 kit contents (items below can be ordered separately):

#	Part Number	Item	Quantity
1	EV2667-C-00A	MP2667 evaluation board	1
2	EVKT-USB2I2C-02-bag	Include one USB to I <sup>2</sup> C communication interface, one USB cable, and one ribbon cable	1
3	Online resources	Include datasheet, user guide, product brief, and GUI	1

**Order direct from [MonolithicPower.com](http://MonolithicPower.com) or our distributors.**

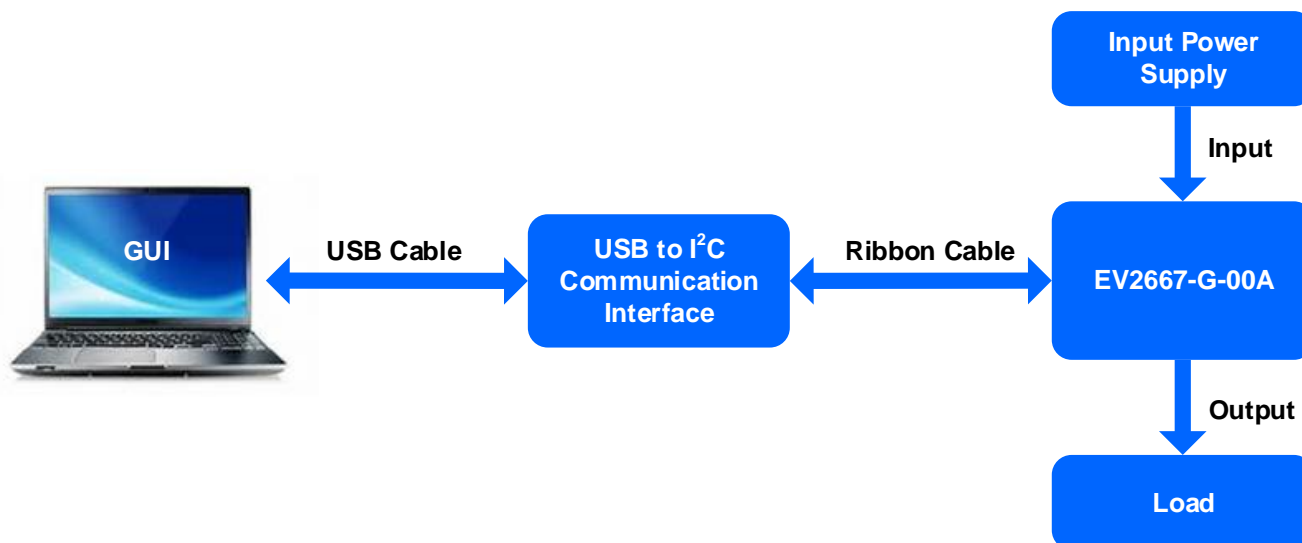

**Figure 1: EVKT-MP2667 Evaluation Kit Set-Up**

## PACKAGE REFERENCE

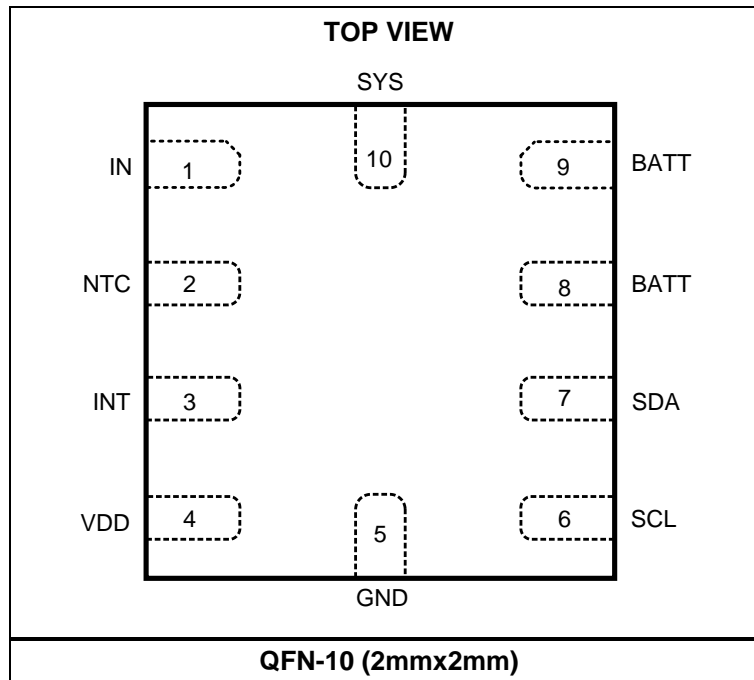

## PIN FUNCTIONS

Pin #	Name	I/O	Description
1	IN	Power	<b>Input power pin.</b> Place a $\geq 1\mu\text{F}$ ceramic capacitor from IN to GND, as close to the IC as possible.
2	NTC	I	<b>Temperature sense input.</b> Connect a negative temperature coefficient thermistor to NTC. Program the hot and cold temperature window with a resistor divider from IN to NTC to GND. The charge is suspended when NTC is out of range.
3	INT	O	<b>Interrupt output.</b> INT can send the charging status and fault interrupt signal to the host. INT is also used to disconnect the system from the battery. Pull INT from high to low for $>8\text{s}$ to disconnect the battery from the system. The external pull-up resistor at INT must be greater than $100\text{k}\Omega$ .
4	VDD	I	<b>Internal control power supply.</b> Connect a ceramic capacitor ( $0.1\mu\text{F}$ ) from VDD to GND. No external load is allowed.
5	GND	Power	<b>Ground.</b>
6	SCL	I/O	<b>I<sup>2</sup>C interface clock.</b> Connect SCL to the logic rail through a $10\text{k}\Omega$ resistor.
7	SDA	I/O	<b>I<sup>2</sup>C interface data.</b> Connect SDA to the logic rail through a $10\text{k}\Omega$ resistor.
8, 9	BATT	Power	<b>Battery pin.</b> Place a ceramic capacitor from BATT to GND, as close to the IC as possible.
10	SYS	Power	<b>System power supply.</b> Place a ceramic capacitor from SYS to GND, as close to the IC as possible.

**ABSOLUTE MAXIMUM RATINGS** <sup>(1)</sup>

V <sub>IN</sub> .....	-0.3V to +13V
All other pins to GND .....	-0.3V to +6.0V
Continuous power dissipation (T <sub>A</sub> = +25°C) <sup>(2)</sup>	1.25W
Junction temperature .....	150°C
Lead temperature (solder) .....	260°C
Storage temperature .....	-65°C to +150°C

**Recommended Operating Conditions** <sup>(3)</sup>

Supply voltage (V <sub>IN</sub> ) .....	4.35V to 5.5V (USB input)
I <sub>IN</sub> .....	Up to 1A
I <sub>SYS</sub> .....	Up to 1.6A
I <sub>CHG</sub> .....	Up to 1A
V <sub>BATT</sub> .....	Up to 4.545V
Operating junction temp (T <sub>J</sub> ) ....	-40°C to +125°C

<b>Thermal Resistance</b> <sup>(4)</sup>	<b>θ<sub>JA</sub></b>	<b>θ<sub>JC</sub></b>
QFN-10 (2mmx2mm) .....	80....	16... °C/W

**Notes:**

- 1) Exceeding these ratings may damage the device.
- 2) The maximum allowable power dissipation is a function of the maximum junction temperature T<sub>J</sub> (MAX), the junction-to-ambient thermal resistance θ<sub>JA</sub>, and the ambient temperature T<sub>A</sub>. The maximum allowable continuous power dissipation at any ambient temperature is calculated by P<sub>D</sub> (MAX) = (T<sub>J</sub> (MAX) - T<sub>A</sub>) / θ<sub>JA</sub>. Exceeding the maximum allowable power dissipation produces an excessive die temperature, causing the regulator to go into thermal shutdown. Internal thermal shutdown circuitry protects the device from permanent damage.
- 3) The device is not guaranteed to function outside of its operating conditions.
- 4) Measured on JESD51-7, 4-layer PCB.

## ELECTRICAL CHARACTERISTICS

$V_{IN} = 5.0V$ ,  $V_{BATT} = 3.5V$ ,  $T_A = +25^{\circ}C$ , unless otherwise noted.

Parameter	Symbol	Condition	Min	Typ	Max	Units
<b>Input Source and Battery Protection</b>						
Input voltage range	$V_{IN}$				13	V
Input operation voltage	$V_{IN}$		4.35	5.0	5.5	V
Battery input voltage <sup>(5)</sup>	$V_{BATT}$				4.5	V
Input over-voltage protection trigger threshold	$V_{IN\_OVP}$	Input rising threshold	5.85	6.00	6.15	V
Input over-voltage protection recover threshold				367		mV
Input under-voltage lockout threshold	$V_{IN\_UVLO}$	Input rising threshold	3.8	3.9	4.0	V
Input under-voltage lockout threshold hysteresis				180		mV
Input vs. battery voltage headroom threshold	$V_{HDRM}$	Input rising vs. battery	90	110	130	mV
Input vs. battery voltage headroom threshold hysteresis				66		mV
Battery under-voltage lockout threshold	$V_{BATT\_UVLO}$	Battery voltage falling, programmable, $V_{BATT\_UVLO} = 2.8V$	2.6	2.8	3.0	V
Battery UVLO range		Programmable using I <sup>2</sup> C	2.4		3.1	V
Battery under-voltage threshold hysteresis		$V_{BATT\_UVLO} = 2.8V$		227		mV
Battery over-voltage protection threshold	$V_{BATT\_OVP}$	Rising, higher than $V_{BATT\_REG}$		128		mV
		Falling, higher than $V_{BATT\_REG}$		63		
<b>Power Path Management</b>						
System regulation voltage	$V_{SYS\_REG}$	$V_{IN} = 5.5V$ , $I_{SYS} = 10mA$ , $I_{CHG} = 0A$	4.85	5.00	5.15	V
Input current limit range		I <sup>2</sup> C programmable	77		993	mA
Input current limit	$I_{IN\_LIM}$	REG00[2:0] = 000 - 77mA	59	68	77	mA
		REG00[2:0] = 001 - 118mA	95	107	118	
		REG00[2:0] = 011 - 470mA	410	440	470	
		REG00[2:0] = 111 - 993mA	875	934	993	
Input minimum voltage regulation	$V_{IN\_MIN}$	I <sup>2</sup> C-programmable range	3.88		5.08	V
		I <sup>2</sup> C setting $V_{IN\_MIN} = 4.20V$	4.10	4.20	4.30	
		I <sup>2</sup> C setting $V_{IN\_MIN} = 4.60V$	4.50	4.60	4.70	
SYS output voltage	$V_{SYS}$	Charging mode, $V_{IN} = 5.5V$ , $V_{BATT} = 3.7V$	4.85	5.00	5.15	V
		Supplement mode, $V_{BATT} = 3.7V$ , $I_{BATT} = 100mA$	3.6			
		$V_{IN} < V_{IN\_UVLO}$ and $V_{BATT} < V_{BATT\_UVLO}$	0			

**ELECTRICAL CHARACTERISTICS (continued)**
**V<sub>IN</sub> = 5.0V, V<sub>BATT</sub> = 3.5V, T<sub>A</sub> = +25°C, unless otherwise noted.**

Parameter	Symbol	Condition	Min	Typ	Max	Units
IN to SYS switch on resistance	R <sub>ON_Q1</sub>	V <sub>IN</sub> = 5V, I <sub>SYS</sub> = 100mA		300	400	mΩ
Input quiescent current	I <sub>IN_Q</sub>	V <sub>IN</sub> = 5.5V, CE = L, enable, I <sub>CHG</sub> = 0A, I <sub>SYS</sub> = 0A		642		μA
		V <sub>IN</sub> = 5.5V, CE = H, charge disabled		482		
Battery quiescent current	I <sub>BATT_Q</sub>	V <sub>IN</sub> = 5V, CE = L, I <sub>SYS</sub> = 0A, V <sub>BATT</sub> = 4.3V		33		μA
		V <sub>IN</sub> = 0V, CE = H, I <sub>SYS</sub> = 0A, V <sub>BATT</sub> = 4.35V		11	14	
		V <sub>BATT</sub> = 4.5V, V <sub>IN</sub> = V <sub>SYS</sub> = GND, disconnect mode		4.512	5.055	
BFET on resistance	R <sub>ON_Q2</sub>	V <sub>IN</sub> < 2V, V <sub>BATT</sub> = 3.5V, I <sub>SYS</sub> = 100mA		100	150	mΩ
Battery current regulation in discharge mode	I <sub>DSCHG</sub>	Program range	100		1600 <sup>(5)</sup>	mA
BFET switch leakage		V <sub>BATT</sub> = 4.5V, V <sub>IN</sub> = V <sub>SYS</sub> = GND, disconnect mode			1	μA
SYS reverse to BATT switch leakage		V <sub>SYS</sub> = 5V, V <sub>IN</sub> = 4.5V, V <sub>BATT</sub> = GND, CE = H			1.3	μA
Battery discharge function controlled by INT <sup>(5)</sup>	t <sub>INT</sub>	INT pull low lasting time to turn off the battery discharge function		8		s
		Battery FET lasts for the off time before auto-on		500		ms
<b>Battery Charger</b>						
Battery voltage regulation (V <sub>BATT_REG</sub> = 4.2V)	V <sub>BATT</sub>	T = 25°C, I <sub>BATT</sub> = 15mA	4.179	4.200	4.221	V
Battery charge voltage regulation	V <sub>BATT_REG</sub>	Programmable using I <sup>2</sup> C	3.600		4.545	V
		V <sub>BATT_REG</sub> = 3.6V, REG04[7:2] = 000000, T <sub>A</sub> = 25°C	3.582	3.600	3.618	
		V <sub>BATT_REG</sub> = 3.6V, REG04[7:2] = 000000, T <sub>A</sub> = -40°C to +85°C	3.574		3.626	
		V <sub>BATT_REG</sub> = 4.2V, REG04[7:2] = 101000, T <sub>A</sub> = 25°C	4.179	4.200	4.221	
		V <sub>BATT_REG</sub> = 4.2V, REG04[7:2] = 101000, T <sub>A</sub> = -40°C to +85°C	4.170		4.230	
		V <sub>BATT_REG</sub> = 4.35V, REG04[7:2] = 110010, T <sub>A</sub> = 25°C	4.328	4.350	4.372	
		V <sub>BATT_REG</sub> = 4.35V, REG04[7:2] = 110010, T <sub>A</sub> = -40°C to +85°C	4.319		4.381	

**ELECTRICAL CHARACTERISTICS (continued)**
**V<sub>IN</sub> = 5.0V, V<sub>BATT</sub> = 3.5V, T<sub>A</sub> = +25°C, unless otherwise noted.**

Parameter	Symbol	Condition	Min	Typ	Max	Units
Fast charge current	I <sub>CC</sub>	V <sub>IN</sub> = 5V, V <sub>BATT</sub> = 3.8V, programmable range	26		1049 <sup>(5)</sup>	mA
		V <sub>IN</sub> = 5V, V <sub>BATT</sub> = 3.8V, I <sub>CC</sub> [4:0] = 26mA, T <sub>A</sub> = 25°C	19	26	33	
		V <sub>IN</sub> = 5V, V <sub>BATT</sub> = 3.8V, I <sub>CC</sub> [4:0] = 26mA, T <sub>A</sub> = -40°C to +85°C	19		33	
		V <sub>IN</sub> = 5V, V <sub>BATT</sub> = 3.8V, I <sub>CC</sub> [4:0] = 257mA, T <sub>A</sub> = 25°C	239	253	267	
		V <sub>IN</sub> = 5V, V <sub>BATT</sub> = 3.8V, I <sub>CC</sub> [4:0] = 257mA, T <sub>A</sub> = -40°C to +85°C	235		269	
		V <sub>IN</sub> = 5V, V <sub>BATT</sub> = 3.8V, I <sub>CC</sub> [4:0] = 818mA, T <sub>A</sub> = 25°C	764	816	868	
		V <sub>IN</sub> = 5V, V <sub>BATT</sub> = 3.8V, I <sub>CC</sub> [4:0] = 818mA, T <sub>A</sub> = -40°C to +85°C	750		875	
Junction temperature regulation <sup>(5)</sup>	T <sub>J,REG</sub>	Junction temperature regulation REG06[1:0] = 11 – T <sub>J,REG</sub> = 120°C		120		°C
Pre-charge current	I <sub>PRE</sub>	I <sub>TERM</sub> [1:0] = 24mA, T <sub>A</sub> = 25°C	6	15	25	mA
		I <sub>TERM</sub> [1:0] = 24mA, T <sub>A</sub> = -40°C to +85°C	4		27	
		I <sub>TERM</sub> [1:0] = 52mA, T <sub>A</sub> = 25°C	27	40	52	
		I <sub>TERM</sub> [1:0] = 52mA, T <sub>A</sub> = -40°C to 85°C	26		53	
Charge termination current threshold	I <sub>TERM</sub>	Program range	24		108	mA
		I <sub>CC</sub> [4:0] ≤ 521mA, (REG02[4] = 0), I <sub>TERM</sub> [1:0] = 24mA, T <sub>A</sub> = 25°C	7	14	20	
		I <sub>CC</sub> [4:0] ≤ 521mA, (REG02[4] = 0), I <sub>TERM</sub> [1:0] = 24mA, T <sub>A</sub> = -40°C to +85°C	6		21	
		I <sub>CC</sub> [4:0] ≤ 521mA, (REG02[4] = 0), I <sub>TERM</sub> [1:0] = 52mA, T <sub>A</sub> = 25°C	19	26	33	
		I <sub>CC</sub> [4:0] ≤ 521mA, (REG02[4] = 0), I <sub>TERM</sub> [1:0] = 52mA, T <sub>A</sub> = -40°C to +85°C	17		35	
		I <sub>CC</sub> [4:0] ≥ 554mA, (REG02[4] = 1), I <sub>TERM</sub> [1:0] = 24mA, T <sub>A</sub> = 25°C	20	28	36	
		I <sub>CC</sub> [4:0] ≥ 554mA, (REG02[4] = 1), I <sub>TERM</sub> [1:0] = 24mA, T <sub>A</sub> = -40°C to +85°C	17		37	
		I <sub>CC</sub> [4:0] ≥ 554mA, (REG02[4] = 1), I <sub>TERM</sub> [1:0] = 52mA, T <sub>A</sub> = 25°C	42	52	63	
		I <sub>CC</sub> [4:0] ≥ 554mA, (REG02[4] = 1), I <sub>TERM</sub> [1:0] = 52mA, T <sub>A</sub> = -40°C to +85°C	39		68	
Pre-charge to fast charge threshold	V <sub>BATT,PRE</sub>	V <sub>BATT</sub> rising, set V <sub>BATT,PRE</sub> = 3.0V	2.8	3.0	3.1	V
Pre-charge to fast charge threshold hysteresis				97		mV
Auto-recharge battery voltage threshold	V <sub>RECH</sub>	REG04[0] = 0	140	170	220	mV
		REG04[0] = 1	270	320	370	



**ELECTRICAL CHARACTERISTICS (continued)**
**V<sub>IN</sub> = 5V, T<sub>A</sub> = 25°C, unless otherwise noted.**

Parameter	Symbol	Condition	Min	Typ	Max	Units
<b>Thermal Protection</b>						
Thermal shutdown threshold <sup>(5)</sup>	T <sub>J_SHDN</sub>			150		°C
Thermal shutdown hysteresis <sup>(5)</sup>				20		°C
NTC output current	I <sub>NTC</sub>	CE = L, V <sub>NTC</sub> = 3V	-100	0	100	nA
NTC cold temperature rising threshold	V <sub>COLD</sub>	As a percentage of V <sub>IN</sub>	64	66	68	%
NTC cold temperature rising threshold hysteresis				30		mV
NTC hot temperature falling threshold	V <sub>HOT</sub>	As a percentage of V <sub>IN</sub>	33	35	37	%
NTC hot temperature falling threshold hysteresis				65		mV
<b>Logic I/O Pin Characteristics<sup>(5)</sup></b>						
Low logic voltage threshold	V <sub>L</sub>				0.4	V
High logic voltage threshold	V <sub>H</sub>		1.3			V
<b>I<sup>2</sup>C Interface (SDA, SCL)</b>						
Input high voltage level	V <sub>IH</sub>	V <sub>PULL_UP</sub> = 1.8V, SDA and SCL	1.3			V
Input low voltage level	V <sub>IL</sub>	V <sub>PULL_UP</sub> = 1.8V, SDA and SCL			0.4	V
Output low voltage level	V <sub>OL</sub>	I <sub>SINK</sub> = 5mA			0.4	V
I <sup>2</sup> C clock frequency	f <sub>SCL</sub>				400	kHz
<b>Digital Clock and Watchdog Timer</b>						
Digital clock 2	f <sub>DIG2</sub>			32		kHz
Watchdog timer	t <sub>WDT</sub>	Programmable (REG05[5:4] = 11)	140	165	190	s
Safety timer for fast charging cycle <sup>(5)</sup>	t <sub>TMR_FAST</sub>	Programmable (REG05[2:1] = 00), t <sub>TMR_FAST</sub> = 20hrs		20		hrs
		Programmable (REG05[2:1] = 01), t <sub>TMR_FAST</sub> = 5hrs		5.0		
		Programmable (REG05[2:1] = 10), t <sub>TMR_FAST</sub> = 8hrs		8.0		
		Programmable (REG05[2:1] = 11), t <sub>TMR_FAST</sub> = 12hrs		12.0		

**Note:**

5) Guaranteed by design.

## TYPICAL CHARACTERISTICS

$V_{IN} = 5V$ ,  $T_A = 25^\circ C$ ,  $I_{IN\_LIM} = 470mA$ ,  $I_{CC} = 257mA$ ,  $V_{IN\_MIN} = 4.6V$ , unless otherwise noted.

**Battery Regulation Voltage vs. Temperature**

$V_{BATT\_REG} = 4.2V$

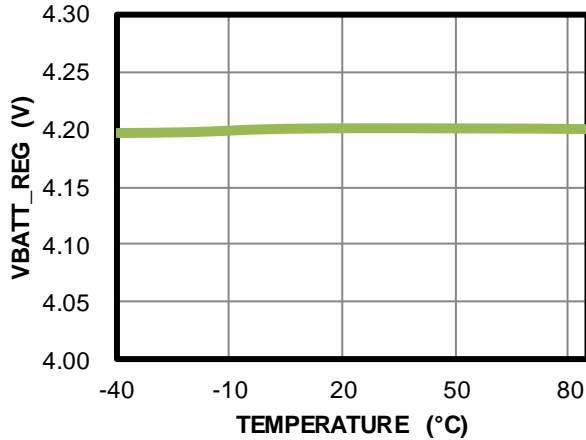

**System Regulation Voltage vs. Temperature**

$V_{SYS\_REG} = 5V$

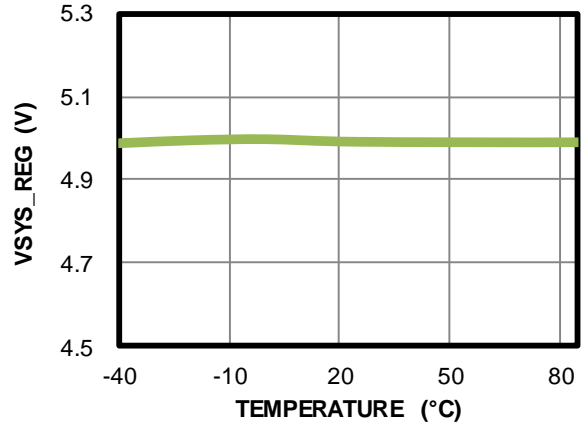

**Battery Current under Shipping Mode vs. Temperature**

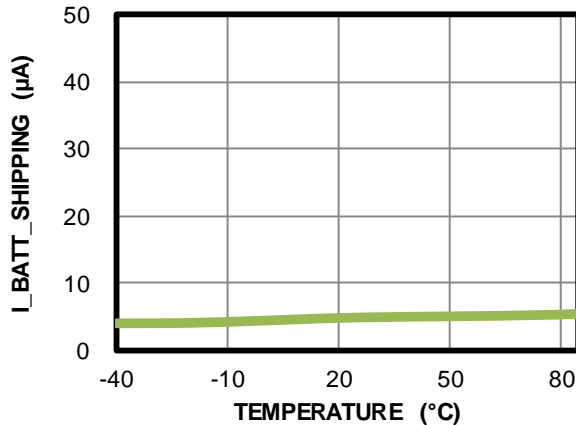

**CC Charge Current vs. Temperature**

$I_{CC} = 257mA$

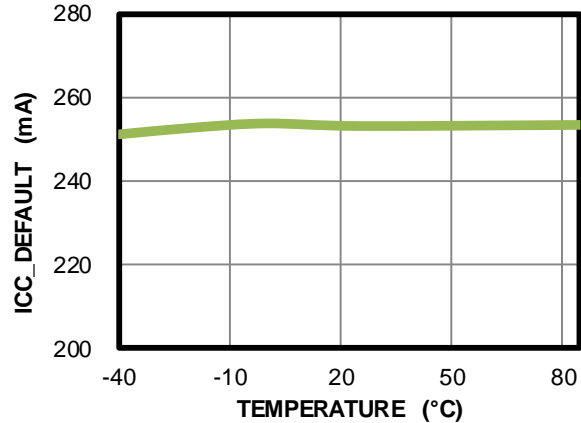

**Battery Termination Current vs. Temperature**

$I_{TERM} = 52mA @ I_{IN\_LIM} = 470mA$ ,  $I_{CC} = 257mA$

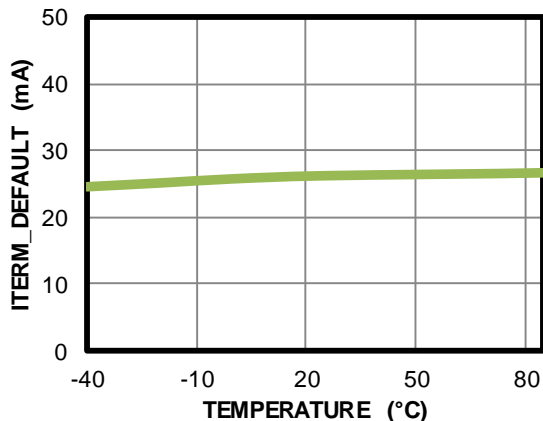

**Battery Termination Current vs. Temperature**

$I_{TERM} = 52mA @ I_{IN\_LIM} = 734mA$ ,  $I_{CC} = 620mA$

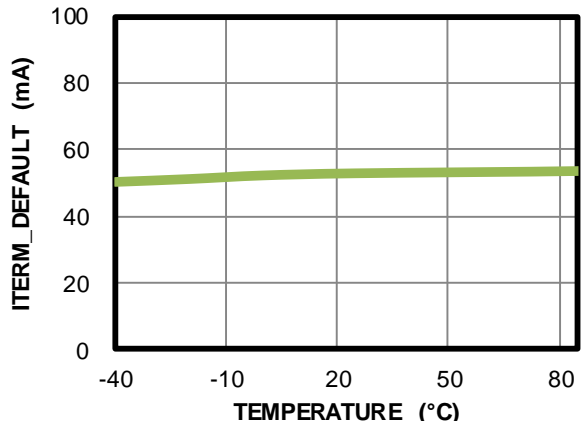

**TYPICAL CHARACTERISTICS (continued)**

$V_{IN} = 5V$ ,  $T_A = 25^{\circ}C$ ,  $I_{IN\_LIM} = 470mA$ ,  $I_{CC} = 257mA$ ,  $V_{IN\_MIN} = 4.6V$ , unless otherwise noted.

**Battery OVP Voltage vs. Temperature**

Rising, higher than  $V_{BATT\_REG}$

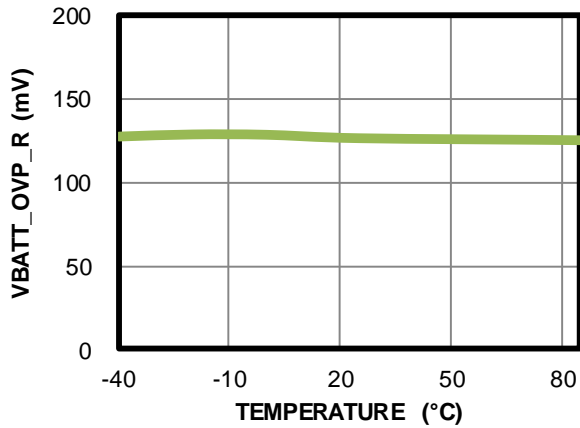

**Input Current Limit vs. Temperature**

$I_{IN\_LIM} = 470mA$

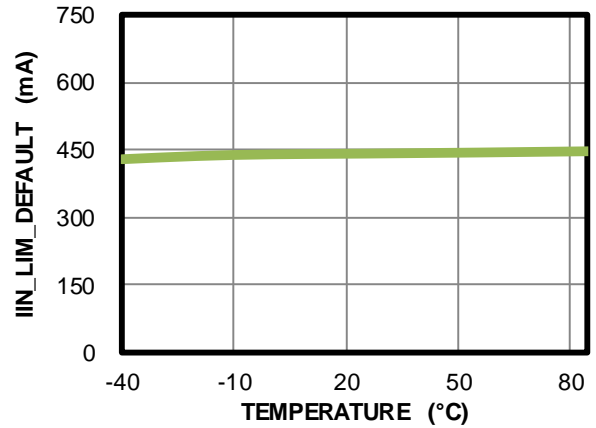

**Input Minimum Voltage vs. Temperature**

$V_{IN\_MIN} = 4.6V$

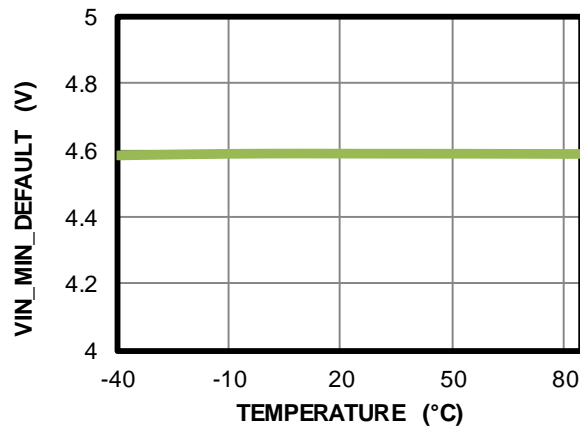

## TYPICAL PERFORMANCE CHARACTERISTICS

$V_{IN} = 5V$ ,  $T_A = 25^\circ C$ ,  $I_{IN\_LIM} = 470mA$ ,  $I_{CC} = 257mA$ ,  $V_{IN\_MIN} = 4.6V$ , unless otherwise noted.

### Battery Charge Curve

$I_{SYS} = 0A$

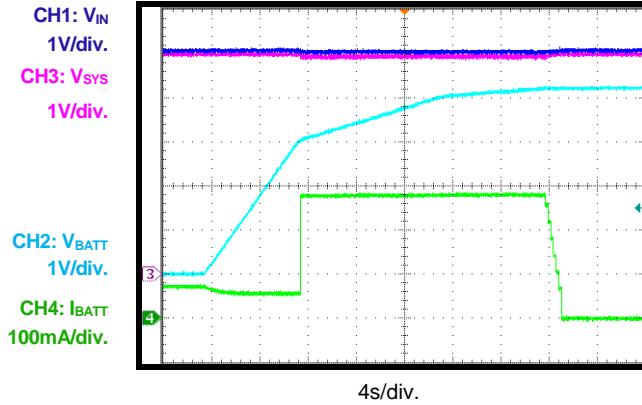

### Auto-Recharge

$I_{SYS} = 0A$

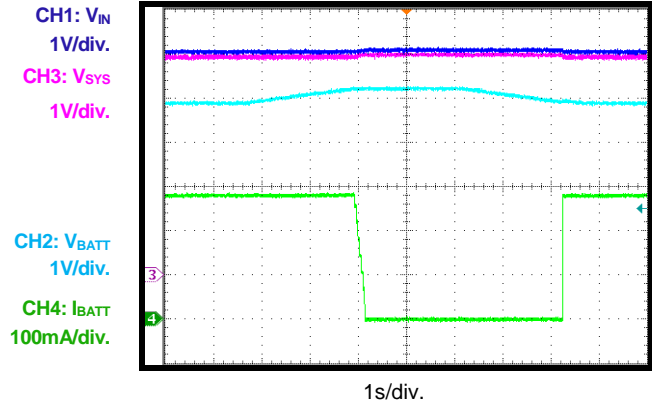

### CC Charge Steady State

$V_{BATT} = 3.7V$ ,  $I_{SYS} = 0A$

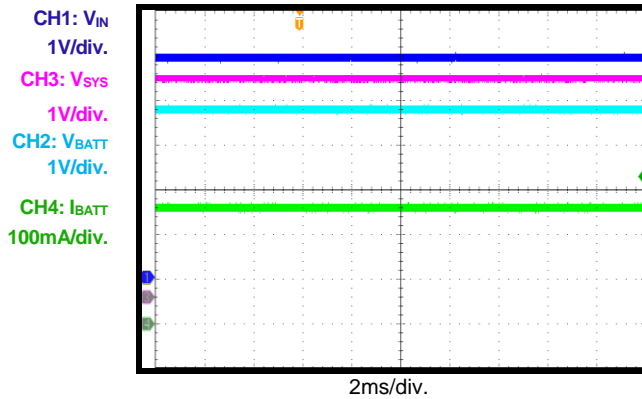

### Input Current Limit-Based PPM

$V_{BATT} = 3.7V$

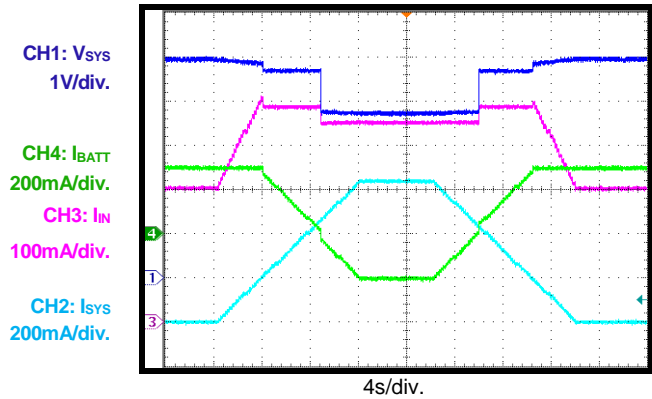

### Input Voltage Regulation-Based PPM

$V_{IN} = 5V/300mA$ ,  $V_{BATT} = 3.7V$

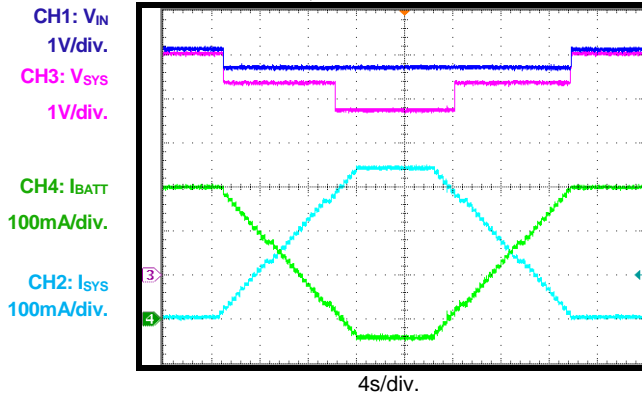

### $V_{IN}$ OVP Operation

$V_{BATT} = 3.7V$ ,  $I_{SYS} = 0A$

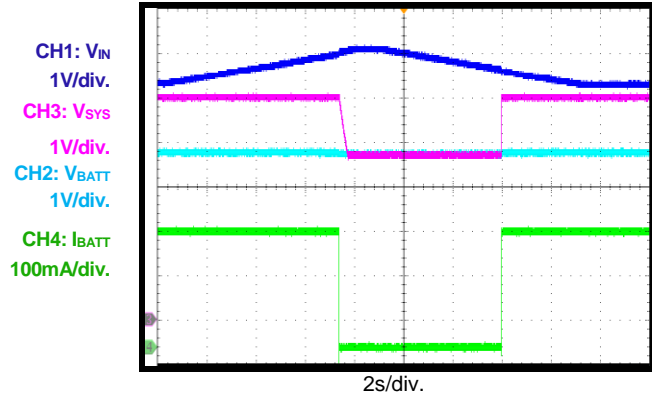

**TYPICAL PERFORMANCE CHARACTERISTICS (continued)**
 $V_{IN} = 5V$ ,  $T_A = 25^\circ C$ ,  $I_{IN\_LIM} = 470mA$ ,  $I_{CC} = 257mA$ ,  $V_{IN\_MIN} = 4.6V$ , unless otherwise noted.

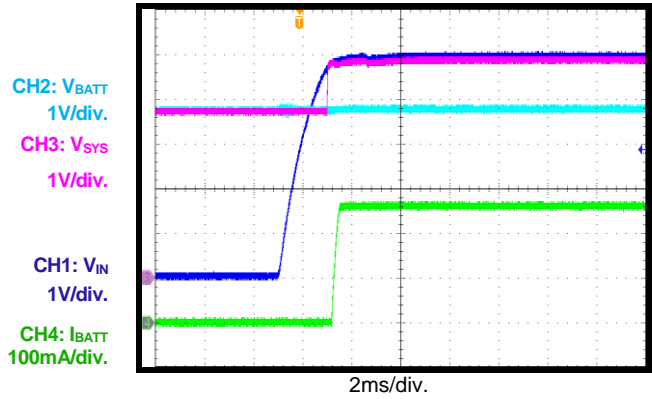
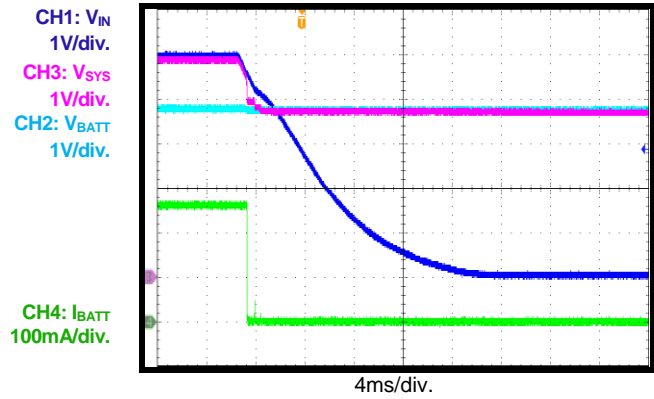
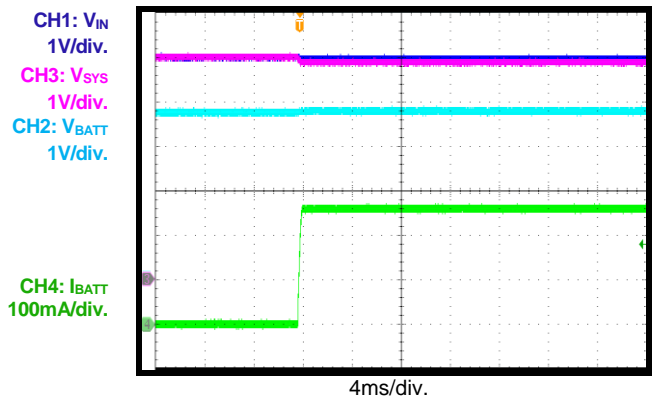
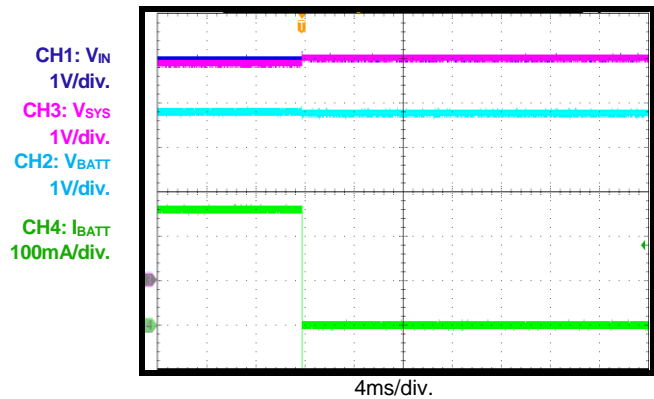
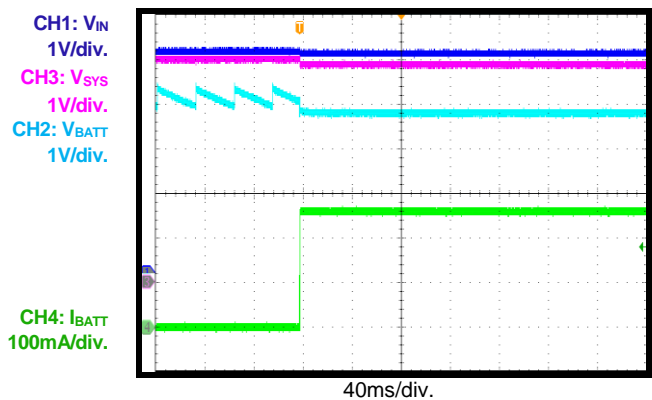
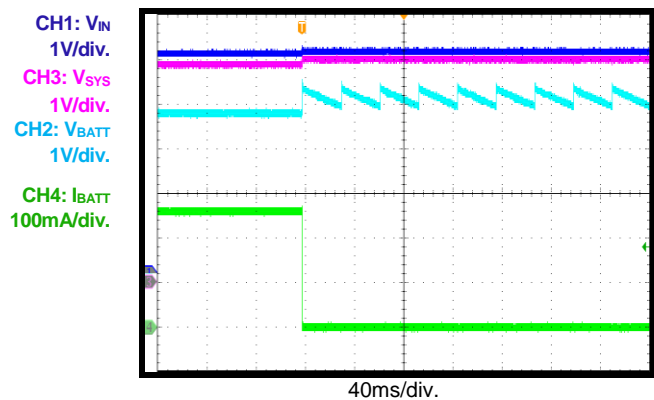
**Power-On**
 $V_{BATT} = 3.7V$ ,  $I_{SYS} = 0A$ 

**Power-Off**
 $V_{BATT} = 3.7V$ ,  $I_{SYS} = 0A$ 

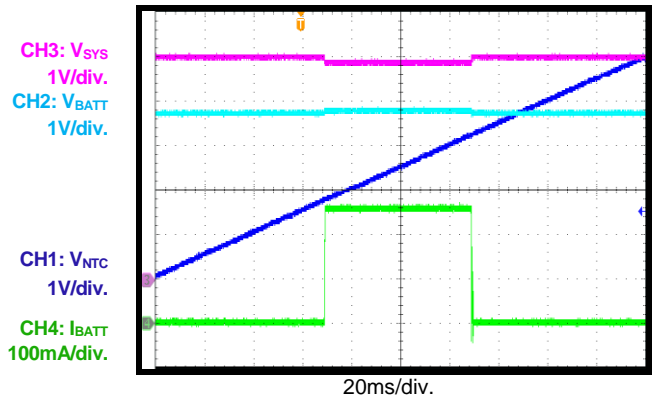
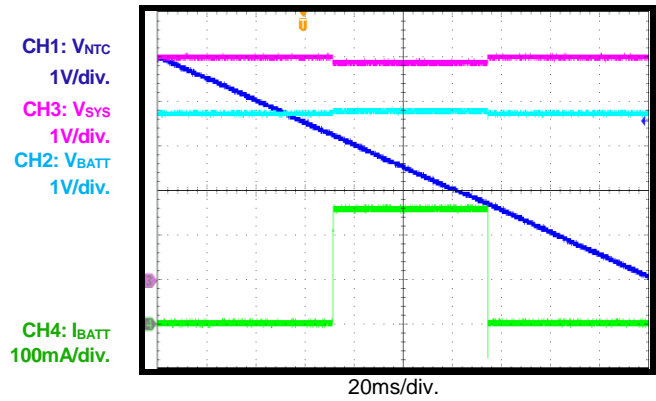
**Charge Enable**
 $V_{BATT} = 3.7V$ ,  $I_{SYS} = 0A$ 

**Charge Disable**
 $V_{BATT} = 3.7V$ ,  $I_{SYS} = 0A$ 

**BATT Insertion**
 $V_{BATT} = 3.7V$ ,  $I_{SYS} = 0A$ 

**BATT Removal**
 $V_{BATT} = 3.7V$ ,  $I_{SYS} = 0A$ 

**TYPICAL PERFORMANCE CHARACTERISTICS (continued)**
 $V_{IN} = 5V$ ,  $T_A = 25^\circ C$ ,  $I_{IN\_LIM} = 470mA$ ,  $I_{CC} = 257mA$ ,  $V_{IN\_MIN} = 4.6V$ , unless otherwise noted.

**NTC Rising**
 $V_{BATT} = 3.7V$ ,  $I_{SYS} = 0A$ 

**NTC Falling**
 $V_{BATT} = 3.7V$ ,  $I_{SYS} = 0A$ 

## FUNCTIONAL BLOCK DIAGRAM

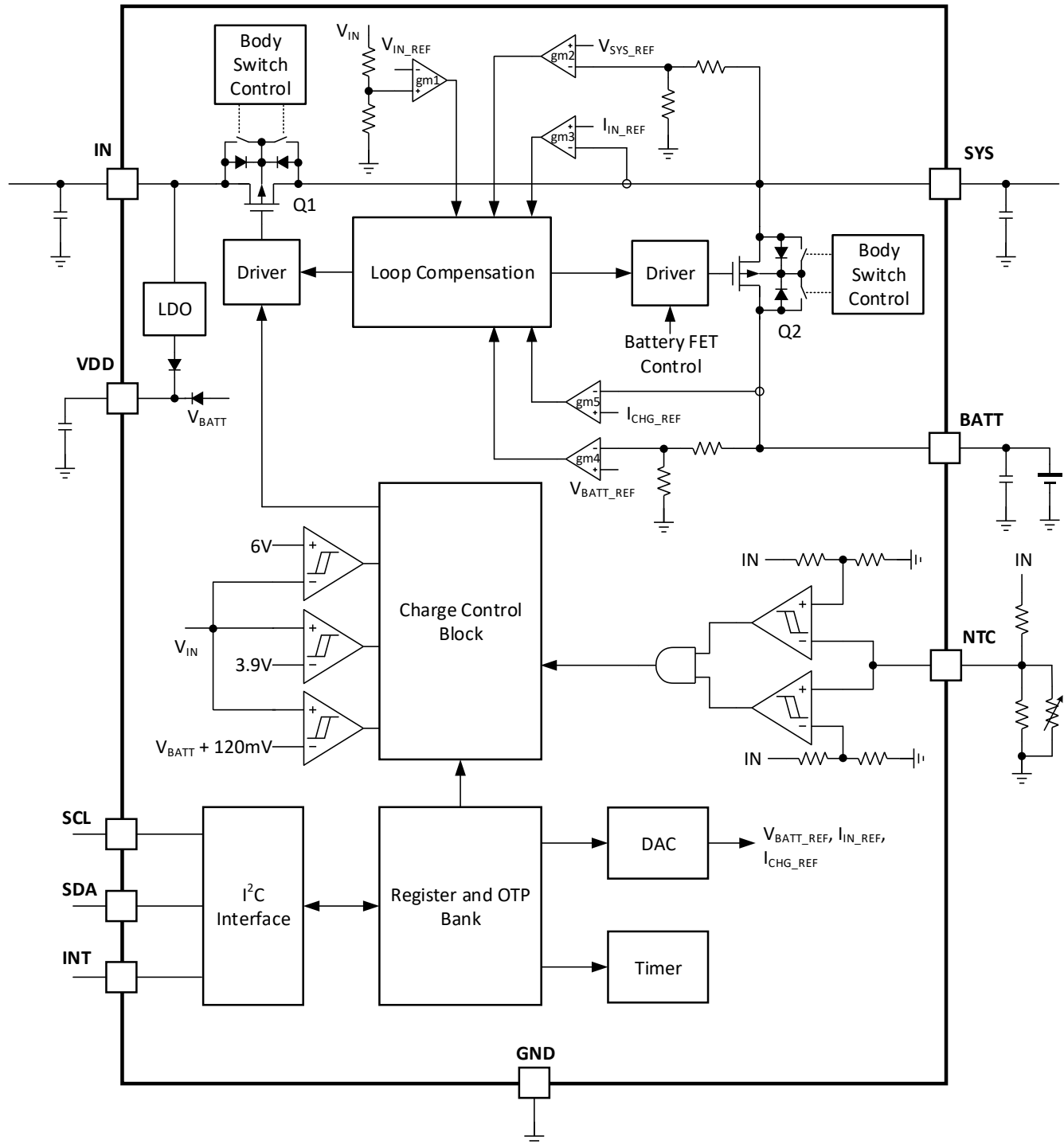

Figure 2: Functional Block Diagram

## OPERATION

The MP2667 is an I<sup>2</sup>C-controlled, single-cell, Li-ion or Li-polymer battery charger with complete power path management. The full charge function features fast charge (CC) and constant voltage (CV) regulation, pre-charge (PRE.C), charge termination, auto-recharge, and a built-in timer. The power path function allows the input source to power the system and charge the battery simultaneously. If the power source cannot supply enough current to the system load and to charge the battery, then the charge current will be reduced until it is necessary for the battery to supplement system power.

The IC integrates a 300mΩ LDO FET between IN and SYS, and a 100mΩ battery FET between SYS and BATT.

During charging mode, the on-chip 100mΩ battery FET works as a full-featured linear charger with pre-charging, CC and CV charging, charge termination, auto-recharging, NTC monitoring, built-in timer control, and thermal protection. The charge current can be programmed via the I<sup>2</sup>C interface. The IC limits the charge current when the die temperature exceeds the programmable thermal regulation threshold (120°C default).

When the input power is not sufficient for powering the system load, the MP2667 enters supplement mode by fully turning on the 100mΩ battery FET. When the input is removed, the 100mΩ battery FET is also fully turned on, allowing the battery to power up the system.

When the system load is satisfied, the remaining current is used to charge the battery. The IC reduces the charging current or uses power from the battery to satisfy the system load when its demand is over the input power capacity, or if either the input current or voltage loops are active.

Figure 3 shows the power path management structure for the MP2667.

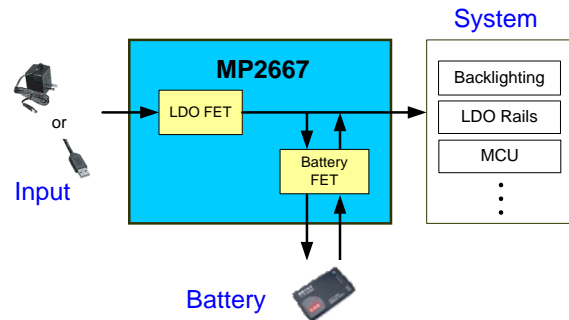

**Figure 3: Power Path Management Structure**

### Power Supply

The internal bias circuit of the IC is powered from the higher voltage of IN or BATT. When IN or BATT rises above the respective under-voltage lockout (UVLO) threshold, the sleep comparator, battery depletion comparator, and battery FET driver are active. The I<sup>2</sup>C interface is ready for communication, and all registers are reset to the default value. The host can access all registers.

### Input OVP and UVLO

The MP2667 has an input over-voltage protection (OVP) threshold and an input UVLO threshold. Once the input voltage transitions out of the normal input voltage range, the Q1 FET immediately turns off.

When the input voltage is identified as a good source, a 200μs immunity timer is active. If the input power is normal until the 200μs timer expires, the system starts up. Otherwise, Q1 remains off (see Figure 4).

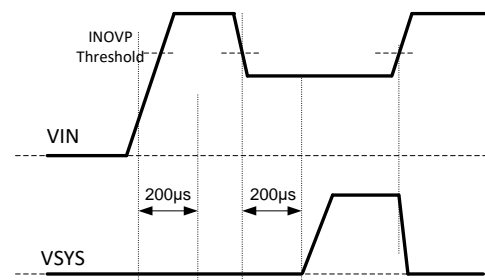

**Figure 4: Input Power Detection Operation**

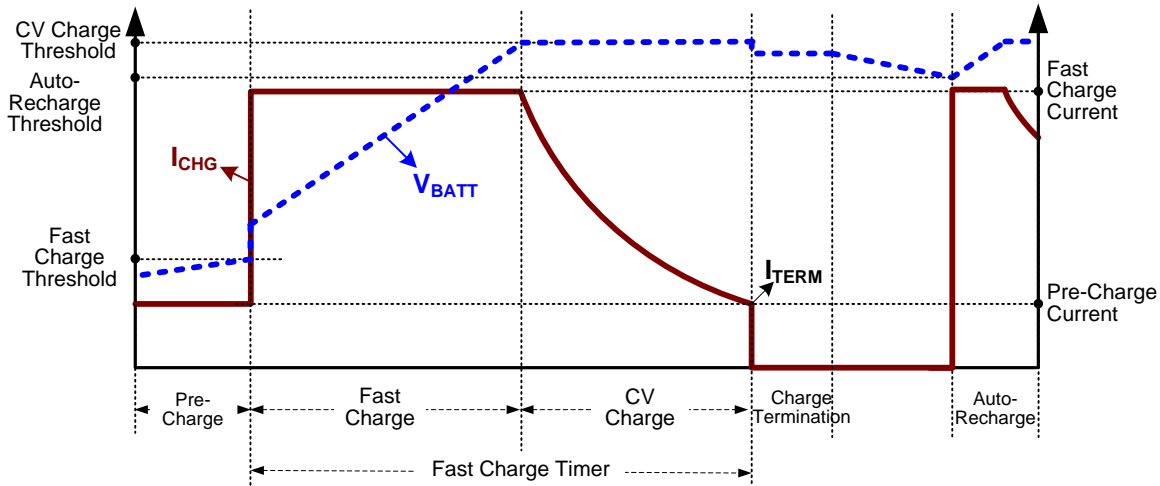

**Figure 5: Battery Charge Profile**

### Power Path Management

The IC employs a direct power path structure with the battery FET decoupling the system from the battery, which allows for separate control between the system and the battery. The system is given the priority to start up even with a deeply discharged or missed battery. When the input power is available, even with a depleted battery, the system voltage is always regulated to  $V_{SYS\_REG}$  by the integrated LDO FET.

The direct power structure is composed of a front-end LDO FET between the IN and SYS pins and a battery FET between the SYS and BATT pins (see Figure 3).

The input LDO (using an LDO FET) provides power to the system, which drives the system load directly and charges the battery through the battery FET.

For the system voltage control, when the input voltage is higher than  $V_{SYS\_REG}$ , the system voltage is regulated to  $V_{SYS\_REG}$ . When the input voltage is lower than  $V_{SYS\_REG}$ , the LDO FET is fully on in dropout with an input current limit.

### Battery Charge Profile

The IC provides three main charging phases: pre-charge, fast charge, and constant-voltage charge (see Figure 5).

1. **Phase 1 (constant current pre-charge):** The IC can safely pre-charge the deeply depleted battery until the battery voltage reaches the pre-charge to fast charge threshold ( $V_{BATT\_PRE}$ ). The pre-charge current is programmable via REG03 bit[1:0]. If  $V_{BATT\_PRE}$  is not reached before the pre-charge timer (2hrs) expires, the charge cycle is stopped, and a corresponding timeout fault signal is asserted.
2. **Phase 2 (constant current fast charge):** When the battery voltage exceeds  $V_{BATT\_PRE}$ , the IC enters a constant-current charge (fast charge) phase. The fast charge current is programmable via REG02 bit[4:0].
3. **Phase 3 (constant-voltage charge):** When the battery voltage rises to the pre-programmable charge full voltage ( $V_{BATT\_REG}$ ), set via REG04 bit[7:2], the charge mode changes from CC mode to CV mode, and the charge current begins to taper off.

Table 2 shows the end of charge (EOC) current threshold ( $I_{TERM}$ ) value setting.

**Table 2:  $I_{TERM}$  Value Table**

Reg02 Bit[4]	$I_{TERM}$ Value
0 ( $I_{CC\_SETTING} \leq 521mA$ )	$50\% * I_{TERM} [1:0]$
1 ( $I_{CC\_SETTING} \geq 554mA$ )	$I_{TERM} [1:0]$

Once the charge current reaches the EOC current threshold ( $I_{TERM}$ ) and the CV loop is still dominated, the IC has three possible actions after a 500 $\mu$ s delay, depending on the settings of EN\_TERM (REG05 bit[6]) and TERM\_TMR (reg05 bit[0]):

1. EN\_TERM = 1, TERM\_TMR = 0, (default spec): The IC terminates the charge and changes the charge status to Charge Done.
2. EN\_TERM = 1, TERM\_TMR = 1: The IC changes the charge status to Charge Done, but the charge current continues tapering off until it reaches 0.
3. EN\_TERM = 0, TERM\_TMR = x: The charge status stays at Charge, but the charge current continues tapering off until it reaches 0.

During the charging process, the actual charge current may be less than the register setting due to other loop regulations, such as dynamic power management (DPM) regulation or thermal regulation. See the Input Current- and Input Voltage-Based Power Management section for details.

If  $I_{TERM}$  is not reached before the safety charge timer expires (see Safety Timer section on page 19), the charge cycle stops and the corresponding timeout fault signal is asserted.

The following conditions can start a new charge cycle:

- The input power is recycled
- Battery charging is enabled by the I<sup>2</sup>C
- Auto-recharge kicks in

However, the following conditions can stop a charge cycle:

- No thermistor fault at NTC
- No safety timer fault
- No battery over-voltage
- Battery FET is not forced to turn off

### Automatic Recharge

When the battery is fully charged and charging is terminated, the battery may be discharged due to system consumption or a self-discharge. When the battery voltage is discharged below the recharge threshold, and  $V_{IN}$  is still in the operating range, the IC begins another new charging cycle automatically without the requirement of restarting a charging cycle

manually. The auto-recharge function is valid only when EN\_TERM = 1 and TERM\_TMR = 0.

### Battery Over-Voltage Protection (OVP)

The IC is designed with a built-in battery over-voltage limit about 120mV higher than  $V_{BATT\_REG}$ . When the battery over-voltage event occurs, the IC immediately suspends charging and asserts a fault.

### Input Current- and Input Voltage-Based Power Management

To meet the input source (usually USB) maximum current limit specification, the IC uses an input current-based power management by monitoring the input current continuously. The total input current limit can be programmable via the I<sup>2</sup>C to prevent the input source from overloading.

If the pre-set input current limit is higher than the rating of the input source, backup input voltage-based power management also works to prevent the input source from being overloaded. If either the input current limit or the input voltage regulation is reached, the Q1 FET between IN and SYS is regulated so that the total input power is limited. As a result, the system voltage drops. Once the system declines to the minimum value of 4.8V or  $V_{SYS\_REG} - 320mV$ , the charge current is reduced to prevent the system voltage from dropping further.

The voltage-based dynamic power management (DPM) regulates the input voltage to  $V_{IN\_MIN}$  when the load is over the input power capacity.  $V_{IN\_MIN}$  is set via the I<sup>2</sup>C, and should be at least 500mV higher than  $V_{BATT\_REG}$  to ensure stable operation of the regulator.

### Battery Supplement Mode

The charge current is reduced to keep the input current or input voltage in regulation when DPM occurs. If the charge current is at zero and the input source is still overloaded due to a heavy system load, the system voltage starts to fall off. Once the system voltage falls below the battery voltage, the IC enters battery supplement mode. When the system voltage is 30mV below the battery voltage, the ideal diode mode is enabled. The battery FET is regulated to maintain

$V_{BATT} - V_{SYS}$  at 22.5mV. If the voltage drop of the battery FET ( $I_{DSCHG} * R_{ON\_BATT}$ ) is greater than 22.5mV, the battery FET is fully turned on to keep the ideal forward voltage. When the system load decreases and  $V_{SYS}$  is higher than  $V_{BATT} + 20mV$ , ideal diode mode is disabled.

Figure 6 shows the dynamic power management and battery supplement mode operation profile.

When  $V_{IN}$  is not available, the IC operates in discharge mode, and the battery FET is always fully on to reduce loss.

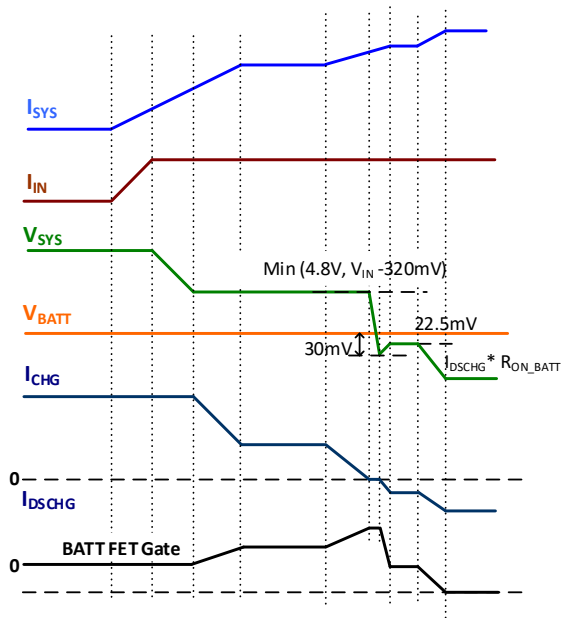

**Figure 6: Dynamic Power Management and Battery Supplement Operation Profile**

### Battery Charge Full Voltage

The battery voltage for the constant voltage regulation phase is  $V_{BATT\_REG}$ . When  $V_{BATT\_REG}$  is 4.2V, it has a  $\pm 0.5\%$  accuracy over the ambient temperature range of 0°C to +50°C. When the battery is removed, the battery voltage is between  $V_{BATT\_REG} - V_{RECH}$  and  $V_{BATT\_REG}$ .

### Thermal Regulation and Thermal Shutdown

The IC monitors the internal junction temperature continuously to maximize power delivery and prevent the chip from overheating. When the internal junction temperature reaches the pre-set limit of  $T_{J\_REG}$  (default 120°C), the IC reduces the charge current to prevent higher power dissipation. The multiple thermal regulation thresholds from 60°C to 120°C help the system design meet the thermal

requirement in different applications. The junction temperature regulation threshold is set via REG06 bit[1:0]. When the junction temperature reaches 150°C, both Q1 and Q2 turn off.

### Negative Temperature Coefficient (NTC) Temperature Sensor

NTC allows the IC to sense the battery temperature using the thermistor, usually available in the battery pack, to ensure a safe operating environment for the chip. Connect appropriately valued resistors from VDD to NTC to ground. The resistor divider works with a thermistor connected from NTC to ground. The voltage on NTC is determined by the resistor divider, whose divide ratio depends on the battery temperature. The IC sets a pre-determined upper and lower bound of the divide ratio internally for NTC cold and NTC hot.

The NTC function works in charge mode only. Once the NTC voltage falls out of the divide ratio (the temperature is outside the safe operating range), the IC stops the charging. Charging resumes automatically after the temperature falls back into the safe range.

### Safety Timer

The IC provides both a pre-charge and a fast charge safety timer to prevent extended charging cycles due to abnormal battery conditions. The pre-charge safety timer is 2 hours when the battery voltage is below  $V_{BATT\_PRE}$ . The fast charge safety timer begins when the battery enters fast charging. Figure 5 shows the definition of the fast charge timer. The fast charge safety timer is programmed through the I<sup>2</sup>C. The safety timer feature can be disabled via the I<sup>2</sup>C.

The following actions restart the safety timer:

- A new charge cycle is initiated
- REG01 bit[3] is written from 0 to 1 (charge enable)
- REG05 bit[3] is written from 0 to 1 (safety timer enable)
- REG01 bit[7] is written from 0 to 1 (software reset)

During PPM, the charge current is reduced because of insufficient input power (input

current limit, input voltage limit), and the timer period can be extended by 2 times through setting TMR2X\_EN (REG06 bit[6]) as 1.

1. **TMR2X\_EN = 1:** Enable 2x extended safety timer during PPM
2. **TMR2X\_EN = 0, (default spec):** Disable 2x extended safety timer during PPM

This feature avoids a false trigger indication for bad battery indication when there is little charge current delivered to the battery as a result of insufficient input power.

### Host Mode and Default Mode

The IC is a host-controlled device. After the power-on reset, the IC starts up in the watchdog timer expiration state or default mode. All registers are in the default settings.

Any write to the IC switches it into host mode. All charge parameters are programmable. If the watchdog timer (REG05 [5:4]) is not disabled, the host must reset the watchdog timer regularly by writing 1 to REG01 bit[6] before the watchdog timer expires to keep the device in host mode. Once the watchdog timer expires, the IC returns to default mode. The watchdog timer limit can also be programmed or disabled by the host control. When there is no  $V_{IN}$ , the watchdog timer is suspended.

Operation also changes to default mode when any of the following conditions occur:

- Refresh input without battery
- Re-insert battery with no  $V_{IN}$
- Register reset REG01 bit[7] is reset

### Battery Discharge Function

If the battery is connected and the input source is missing, the battery FET is fully on when  $V_{BATT}$  is above the  $V_{BATT\_UVLO}$  threshold. The 100m $\Omega$  battery FET minimizes conduction loss during discharge. The quiescent current of the IC is as low as 11 $\mu$ A in this mode. The low on resistance and low quiescent current help extend the running time of the battery.

### Over-Discharge Current Protection

The IC has an over-discharge current protection in discharge mode and supplement mode. Once  $I_{BATT}$  exceeds the programmable discharge current limit (default 1.0A), the battery FET is regulated to limit the discharge current.

Similarly, when the battery voltage falls below the programmable  $V_{BATT\_UVLO}$  threshold (default 2.8V), the battery FET is turned off to prevent over-discharge.

### System Short-Circuit Protection (SCP)

The MP2667 features SYS node short-circuit protection (SCP) for both the IN to SYS path and the BATT to SYS path.

The system voltage is monitored continuously. Once  $V_{SYS}$  is below 1.5V, the over-current protection threshold for the BATT to SYS path is limited to 2A (fast off). For details, see Figure 12.

If the system short-circuit occurs when both the input and the battery are present, the protection mechanisms for both paths work, with the faster one (the IN to SYS path protection mechanism) dominating the hiccup operation.

### Interrupt to Host (INT)

The IC also has an alert mechanism, which can output an interrupt signal via the INT pin to notify the system of the operation by outputting a 256 $\mu$ s low-state INT pulse. Any of the following events will trigger the INT output:

- Good input source detected
- UVLO or input OVP charge completed
- Charging status change
- Any fault in reg08 (watchdog timer fault, input fault, thermal fault, safety timer fault, battery OVP fault, NTC fault)

When any fault occurs, the IC sends out an INT pulse and latches the fault state in reg08. After the IC exits the fault state, the fault bit can be released to 0 after the host reads reg08. The NTC fault is not latched and always reports the current thermistor conditions.

Note that the INT needs the external pull-up resistor for its open-drain connection. A resistance of 100k $\Omega$  or greater is recommended.

### Battery Disconnection Function

In applications where the battery is not removable, it is essential to disconnect the battery from the system to shipping mode, in

stock mode, or to system reset mode, depending on the application (see Table 3).

1. Shipping Mode:

*Entering shipping mode:* The register bit FET\_DIS (REG06 bit[5]), makes the IC enter shipping mode. During normal operation, the battery FET is turned on (the bit is 0). If this bit is set to 1 through the I<sup>2</sup>C, the battery FET is turned off, and the MP2667 enters shipping mode.

The FET\_DIS bit is reset to 0 automatically after the battery FET is turned off.

*Exiting shipping mode:* The IC can exit shipping mode by pulling INT down for a very short time (>500ms).

2. Reset Mode:

The IC can use INT to cut off the path from the battery to the system under the condition needed to reset the system manually.

If the battery FET is on, once the logic at INT is set to low for more than 8s, the battery is disconnected from the system by turning off the battery FET. The battery can be connected in and out of the system by controlling INT (see Figure 7).

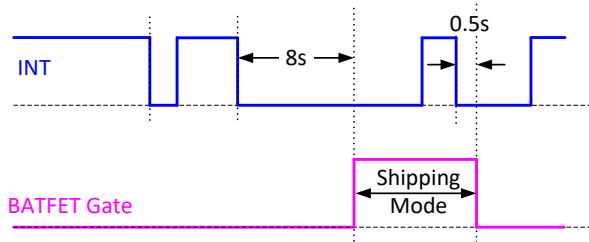

**Figure 7: Disconnection Function Operation Profile**

**Table 3: Battery Disconnection Control**

FET On/Off Change by Control	INT Pin	
	H to L for 8s	H to L for 500ms
	Reset Mode	Exit Shipping Mode
LDO FET	x	x
Battery FET (charging)	Off	On
Battery FET (discharging)	Off	On

## I<sup>2</sup>C REGISTER MAP

IC Address: 09h

### Input Source Control Register / Address: 00h (Default: 0100 1011)

Bit	Symbol	Description	Read/Write	Default
Bit 7	EN_HIZ <sup>(6)</sup>	0: Disable 1: Enable	Read/Write	Default: Disable (0)
<b>Input Minimum Voltage Regulation</b>				
Bit 6	V <sub>IN_MIN</sub> [3]	640mV	Read/Write	Offset: 3.88V Range: 3.88V to 5.08V Default: 4.60V (1001)
Bit 5	V <sub>IN_MIN</sub> [2]	320mV		
Bit 4	V <sub>IN_MIN</sub> [1]	160mV		
Bit 3	V <sub>IN_MIN</sub> [0]	80mV		
<b>Input Current Limit</b>				
Bit 2	I <sub>IN_LIM</sub> [2]	000: 77mA 001: 118mA 010: 345mA 011: 470mA 100: 540mA 101: 635mA 110: 734mA 111: 993mA	Read/Write	Default: 470mA (011)
Bit 1	I <sub>IN_LIM</sub> [1]			
Bit 0	I <sub>IN_LIM</sub> [0]			

**Note:**

6) This bit only controls the on and off of the LDO FET.

### Power-On Configuration Register / Address: 01h (Default: 0000 0100)

Bit	Symbol	Description	Read/Write	Default
Bit 7	Register reset	0: Keep current setting 1: Reset	Read/Write	Keep current register setting (0)
Bit 6	I <sup>2</sup> C watchdog timer reset	0: Normal 1: Reset	Read/Write	Normal (0)
Bit 5	Reserved			
Bit 4	Reserved			
<b>Charger Configuration</b>				
Bit 3	CEB	0: Charge enable 1: Charge disable	Read/Write	Charge enable (0)
<b>Battery UVLO Threshold</b>				
Bit 2	V <sub>BATT_UVLO</sub> [2]	0.4V	Read/Write	Offset: 2.4V Range: 2.4V to 3.1V Default: 2.8V (100)
Bit 1	V <sub>BATT_UVLO</sub> [1]	0.2V		
Bit 0	V <sub>BATT_UVLO</sub> [0]	0.1V		

**I<sup>2</sup>C REGISTER MAP (continued)**
**Charge Current Control Register / Address: 02h (Default: 0000 0111)**

Bit	Symbol	Description	Read/Write	Default
Bit 7	Reserved			
Bit 6	Reserved			
Bit 5	Reserved			
<b>Fast Charge Current Setting</b>				
Bit 4	I <sub>CC</sub> [4]	528mA	Read/Write	Offset: 26mA Range: 26mA to 1049mA Default: 257mA (00111)
Bit 3	I <sub>CC</sub> [3]	264mA		
Bit 2	I <sub>CC</sub> [2]	132mA		
Bit 1	I <sub>CC</sub> [1]	66mA		
Bit 0	I <sub>CC</sub> [0]	33mA		

**Discharge / Termination Current / Address: 03h (Default: 0100 1001)**

Bit	Symbol	Description	Read/Write	Default
Bit 7	Reserved			
<b>BATT to SYS Discharge Current Limit</b>				
Bit 6	I <sub>DSCHG</sub> [3]	800mA	Read/Write	Offset: 100mA Range: 100mA to 1.6A Default: 1.0A (1001)
Bit 5	I <sub>DSCHG</sub> [2]	400mA		
Bit 4	I <sub>DSCHG</sub> [1]	200mA		
Bit 3	I <sub>DSCHG</sub> [0]	100mA		
Bit 2	Reserved			
<b>Terminal Current</b>				
Bit 1	I <sub>TERM</sub> [1]	56mA	Read/Write	Offset: 24mA Range: 24mA to 108mA Default: 52mA (01)
Bit 0	I <sub>TERM</sub> [0]	28mA		

**I<sup>2</sup>C REGISTER MAP (continued)**
**Charge Voltage Control Register / Address: 04h (Default: 1010 0011)**

Bit	Symbol	Description	Read/Write	Default
<b>Battery Regulation Voltage</b>				
Bit 7	V <sub>BATT_REG</sub> [5]	480mV	Read/Write	Offset: 3.60V Range: 3.60V to 4.545V Default: 4.2V (101000)
Bit 6	V <sub>BATT_REG</sub> [4]	240mV		
Bit 5	V <sub>BATT_REG</sub> [3]	120mV		
Bit 4	V <sub>BATT_REG</sub> [2]	60mV		
Bit 3	V <sub>BATT_REG</sub> [1]	30mV		
Bit 2	V <sub>BATT_REG</sub> [0]	15mV		
<b>Pre-Charge to Fast Charge Threshold</b>				
Bit 1	V <sub>BATT_PRE</sub>	0: 2.8V 1: 3.0V	Read/Write	3.0V (1)
<b>Battery Recharge Threshold (below V<sub>BATT_REG</sub>)</b>				
Bit 0	V <sub>RECH</sub>	0: 150mV 1: 300mV	Read/Write	300mV (1)

**Charge Termination / Timer Control Register / Address: 05h (Default: 0100 1010)**

Bit	Symbol	Description	Read/Write	Default
Bit 7	Reserved			
<b>Termination Setting (Control of the Termination is Allowed or Not)</b>				
Bit 6	EN_TERM	0: Disable 1: Enable	Read/Write	Enable (1)
<b>I<sup>2</sup>C Watchdog Timer Limit</b>				
Bit 5	WATCHDOG [1]	00: Disable timer 01: 40s	Read/Write	Disable timer (00)
Bit 4	WATCHDOG [0]	10: 80s 11: 160s		
<b>Safety Timer Setting</b>				
Bit 3	EN_TIMER	0: Disable 1: Enable	Read/Write	Enable timer (1)
<b>Safety Timer for Fast Charging Cycle</b>				
Bit 2	CHG_TMR [1]	00: 20hrs 01: 5hrs	Read/Write	5hrs (01)
Bit 1	CHG_TMR [0]	10: 8hrs 11: 12hrs		
<b>Termination Timer Control (When TERM_TMR is Enabled, the IC Will Not Suspend the Charge Current After Charge Termination)</b>				
Bit 0	TERM_TMR	0: Disable 1: Enable	Read/Write	Disable (0)



**I<sup>2</sup>C REGISTER MAP (continued)**
**Miscellaneous Operation Control Register / Address: 06h (Default: 0000 1011)**

Bit	Symbol	Description	Read/Write	Default
Bit 7	Reserved			
Bit 6	TMR2X_EN	0: Disable 2x extended safety timer during PPM 1: Enable 2x extended safety timer during PPM	Read/Write	Disable (0)
Bit 5	FET_DIS <sup>(7)</sup>	0: Enable 1: Turn off	Read/Write	Enable (0)
Bit 4	Reserved			
Bit 3	EN_NTC	0: Disable 1: Enable	Read/Write	Enable (1)
Bit 2	Reserved			
<b>Thermal Regulation Threshold</b>				
Bit 1	T <sub>J</sub> _REG [1]	00: 60°C 01: 80°C 10: 100°C 11: 120°C	Read/Write	Default: 120°C (11)
Bit 0	T <sub>J</sub> _REG [0]			

**Note:**

7) This bit only controls the on and off of the battery FET, including charge and discharge.

**System Status Register / Address: 07h (Default: 0000 0000)**

Bit	Symbol	Description	Read/Write	Default
Bit 7	Reserved			
<b>Revision</b>				
Bit 6	Rev [1]	Revision number	Read-only	(00)
Bit 5	Rev [0]			
Bit 4	CHG_STAT [1]	00: Not charging 01: Pre-charge 10: Charge 11: Charge done	Read-only	Not charging (00)
Bit 3	CHG_STAT [0]			
Bit 2	PPM_STAT	0: No PPM 1: In PPM	Read-only	No PPM (0) (no power-path management happens)
Bit 1	PG_STAT	0: Power fail 1: Power good	Read-only	Not power good (0)
Bit 0	THERM_STAT	0: No thermal regulation 1: In thermal regulation	Read-only	Normal (0)

**I<sup>2</sup>C REGISTER MAP (continued)**
**Fault Register / Address: 08h (Default: 0000 0000)**

Bit	Symbol	Description	Read/Write	Default
Bit 7	Reserved			
Bit 6	WATCHDOG_FAULT	0: Normal 1: Watchdog timer expiration	Read-only	Normal (0)
Bit 5	VIN_FAULT	0: Normal 1: Input fault (OVP or bad source)	Read-only	Normal (0)
Bit 4	THEM_SD	0: Normal 1: Thermal shutdown	Read-only	Normal (0)
Bit 3	BAT_FAULT	0: Normal 1: Battery OVP	Read-only	Normal (0)
Bit 2	STMR_FAULT	0: Normal 1: Safety timer expiration	Read-only	Normal (0)
Bit 1	Reserved			
Bit 0	Reserved			

**ONE-TIME PROGRAMMING MAP**

#	Bit7	Bit6	Bit5	Bit4	Bit3	Bit2	Bit1	Bit0
0x02	N/A			I <sub>CC</sub> : 26mA to 1049mA / 33mA step				
0x03	N/A						I <sub>TERM</sub>	
0x04	V <sub>BATT_REG</sub> : 3.6V to 4.545V / 15mV step						N/A	
0x05	N/A		WATCHDOG		N/A			

**ONE-TIME PROGRAMMING DEFAULT**

One-Time Programmable Items	Default
I <sub>CC</sub>	257mA
I <sub>TERM</sub>	52mA
V <sub>BATT_REG</sub>	4.2V
WATCHDOG	Disable timer

**STATE CONVERSION CHART**

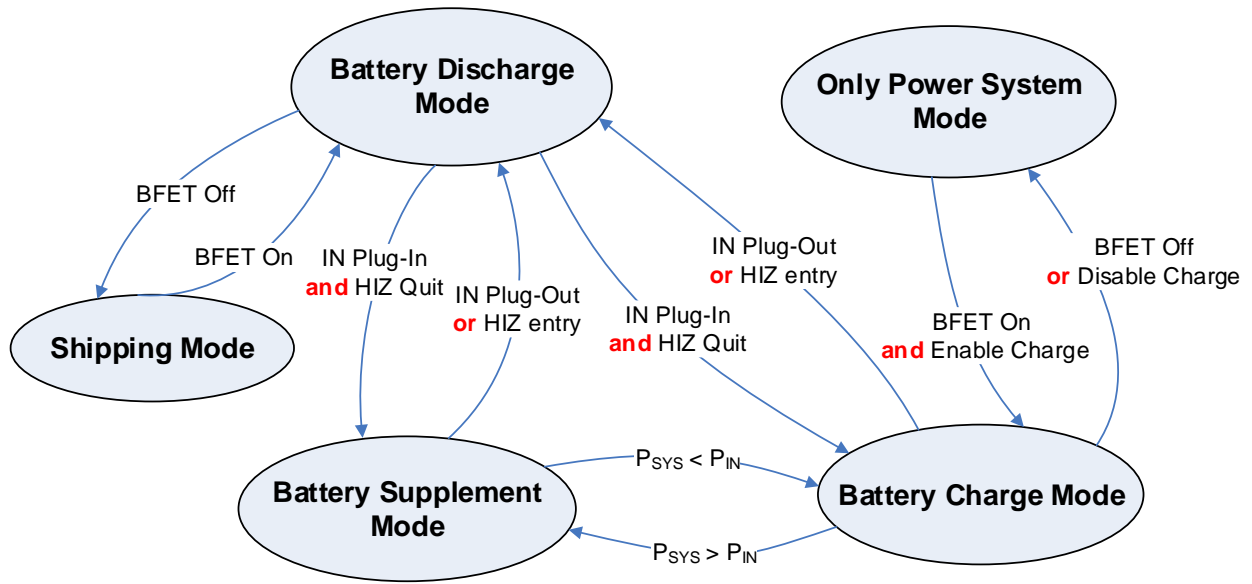

**Figure 8: State Machine Conversion**

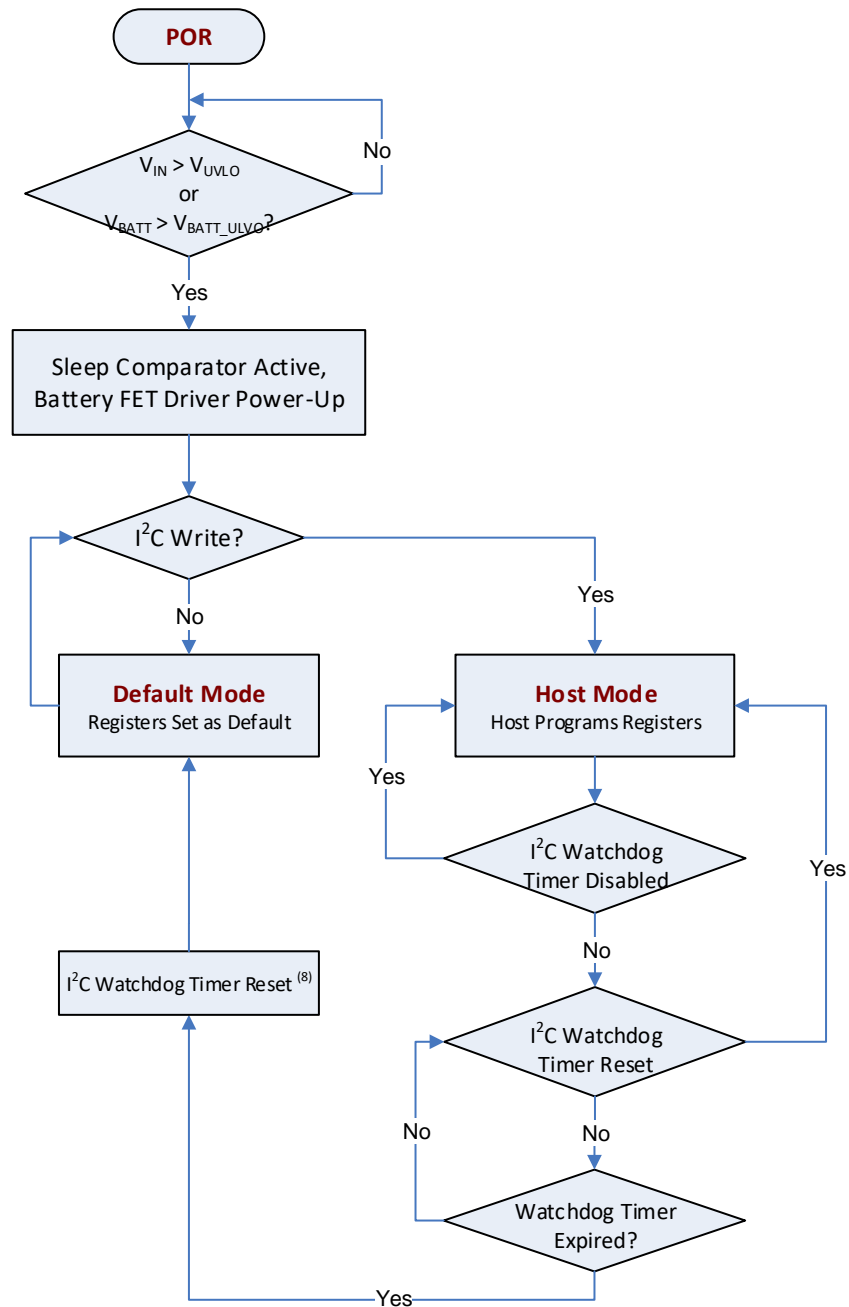
**CONTROL FLOWCHART**

**Figure 9: Default Mode and Host Mode Selection <sup>(9)</sup>**
**Note:**

- 8) Once the watchdog timer expires, the I<sup>2</sup>C watchdog timer reset is required, or the watchdog timer is not valid in the next cycle.  
 9) The watchdog timer is held when V<sub>IN</sub> is not present.

CONTROL FLOWCHART (continued)

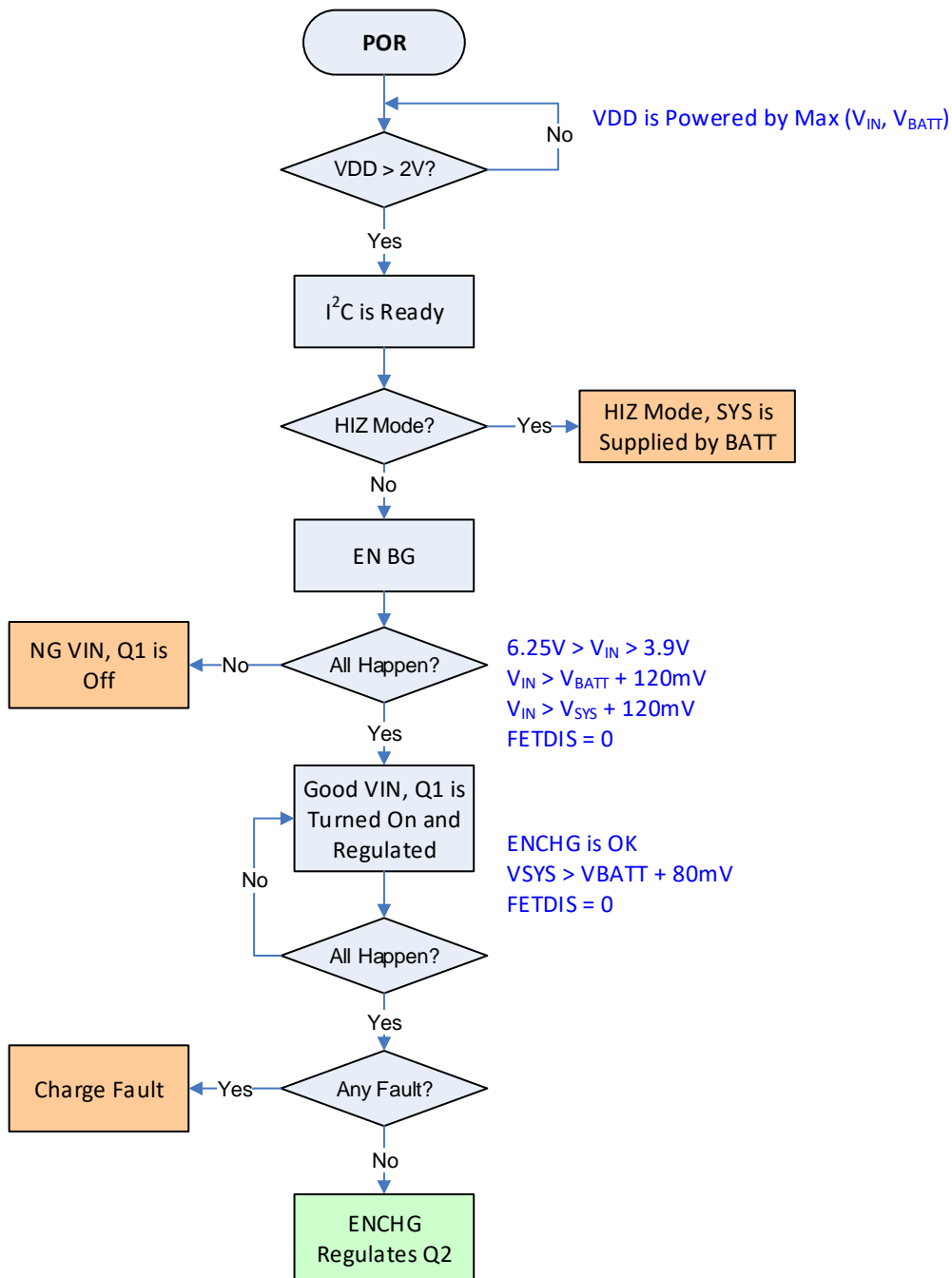

Figure 10: Input Power Start-Up Flowchart

CONTROL FLOWCHART (continued)

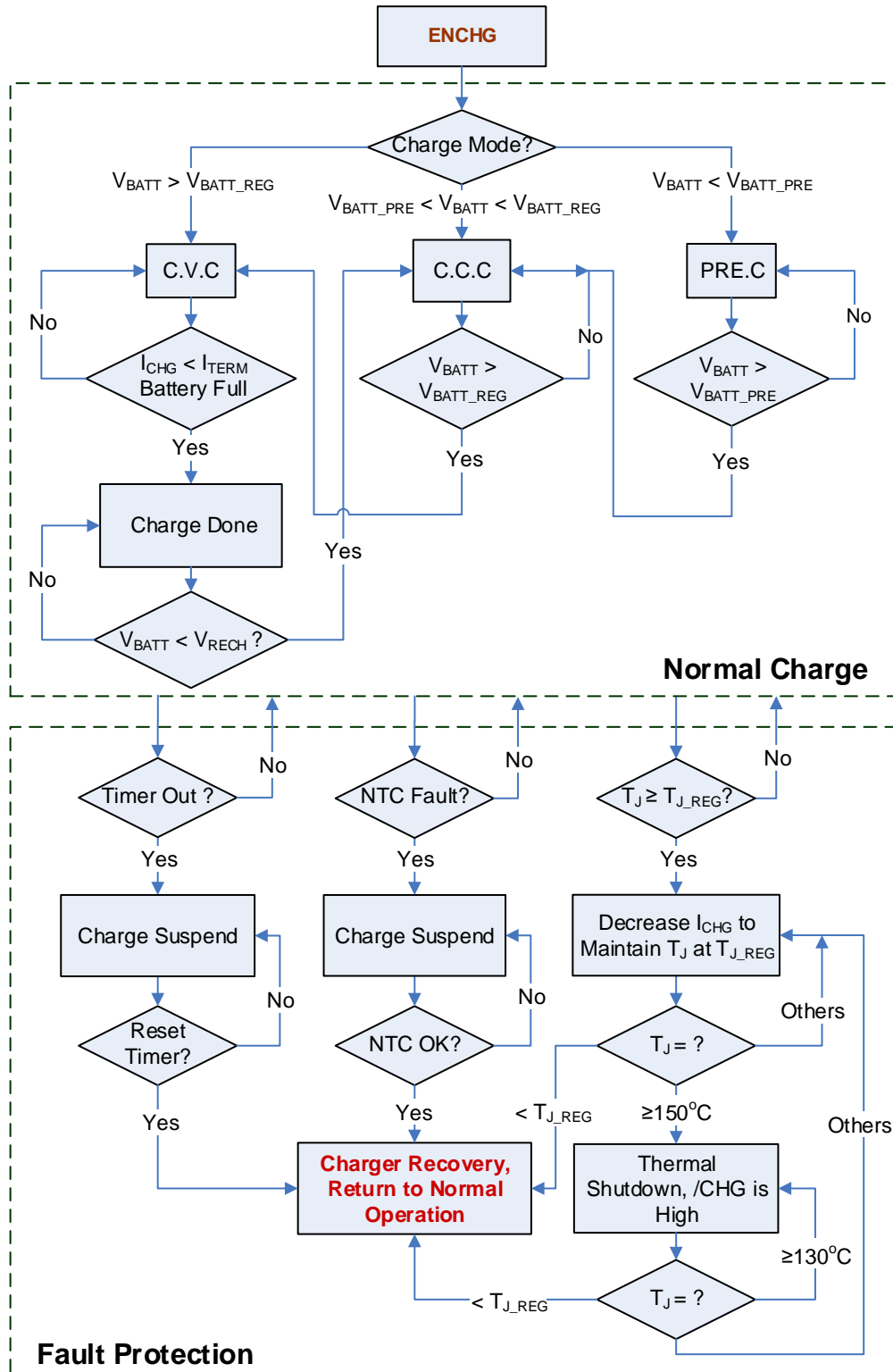
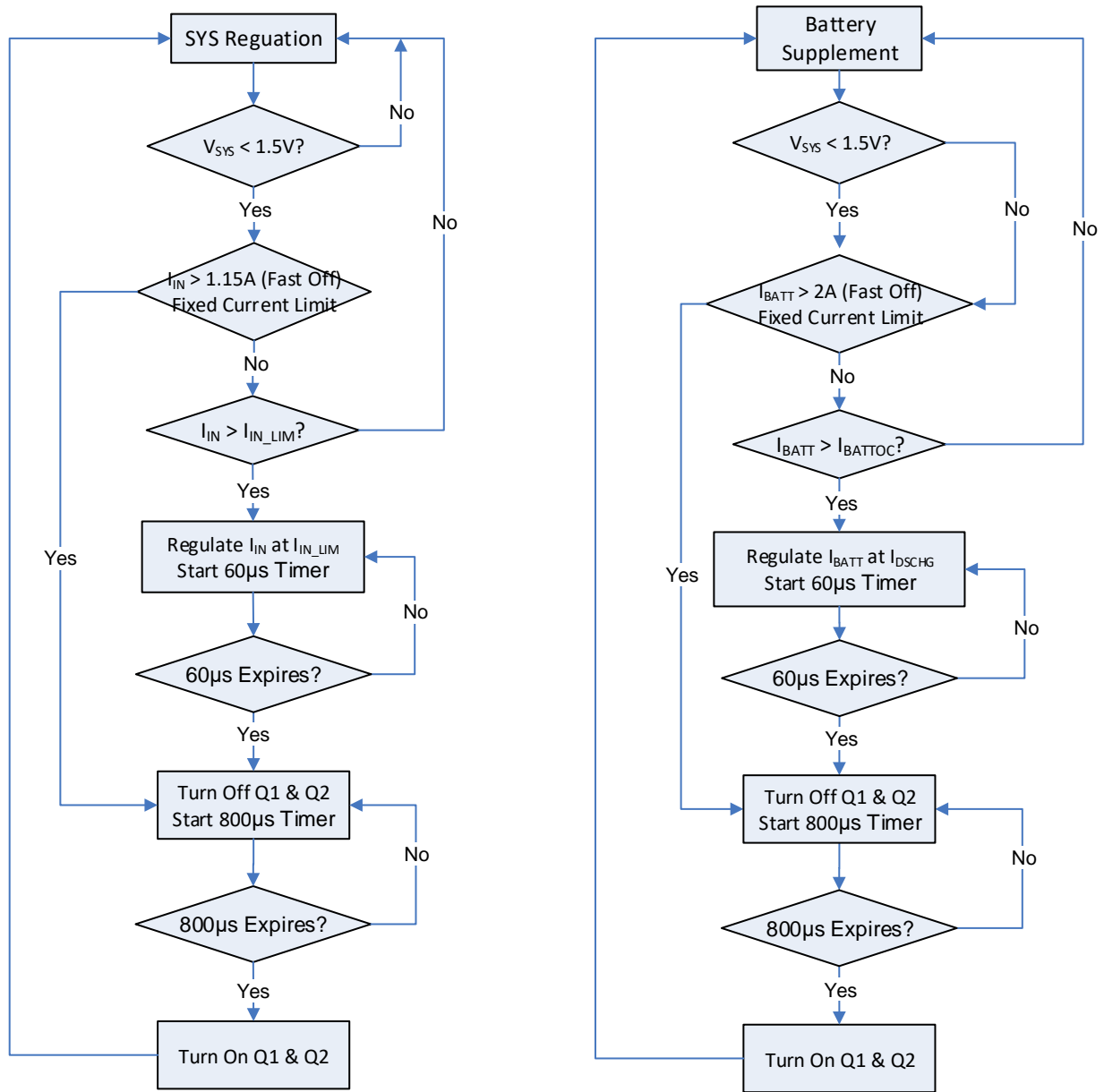

Figure 11: Charging Process

**CONTROL FLOWCHART (continued)**

**Figure 12: System Short-Circuit Protection**



## APPLICATION INFORMATION

### Selecting a Resistor for the NTC Sensor

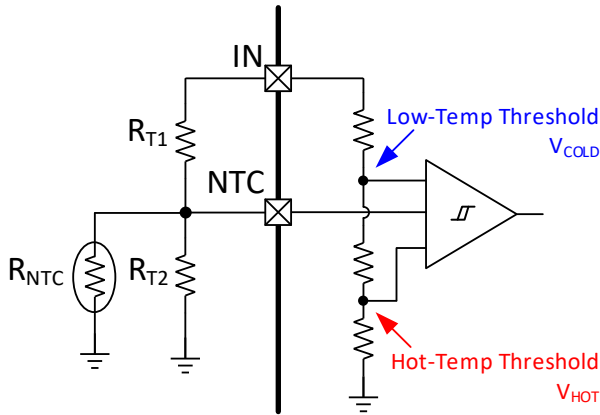
Figure 13 shows an internal resistor divider reference circuit to limit the low-temperature threshold and high-temperature threshold at  $V_{HOT}$  and  $V_{COLD}$ , respectively.



**Figure 13: NTC Function Block**

For a given NTC thermistor, set the NTC window by selecting appropriate  $R_{T1}$  and  $R_{T2}$  values with Equation (1) and Equation (2):

$$\frac{R_{T2} // R_{NTC\_Cold}}{R_{T1} + R_{T2} // R_{NTC\_Cold}} = V_{COLD} \quad (1)$$

$$\frac{R_{T2} // R_{NTC\_Hot}}{R_{T1} + R_{T2} // R_{NTC\_Hot}} = V_{HOT} \quad (2)$$

Where  $R_{NTC\_Hot}$  is the NTC resistor value at the high end of the required temperature operation range, and  $R_{NTC\_Cold}$  is the NTC resistor value at a low temperature. The two resistors ( $R_{T1}$  and  $R_{T2}$ ) allow the high-temperature limit and low-temperature limit to be programmed independently. With this feature, the MP2667 can fit most NTC resistor types and different temperature operation range requirements.

The  $R_{T1}$  and  $R_{T2}$  values depend on the type of NTC resistor used. For example, for the thermistor 103AT-2,  $R_{NTC\_Cold}$  is 27.28k $\Omega$  at 0°C, and  $R_{NTC\_Hot}$  is 4.16k $\Omega$  at 50°C.

Equation (1) and Equation (2) can be used to calculate  $R_{T1} = 6.59k\Omega$  and  $R_{T2} = 24.07k\Omega$ , assuming that the NTC window is between 0°C and 50°C, and using the  $V_{COLD}$  and  $V_{HOT}$  values from the EC table.

### Selecting the External Capacitor

Like most low-dropout regulators, the MP2667 requires external capacitors for regulator stability and voltage spike immunity. The device is designed specifically for portable applications requiring minimal board space and small components. These capacitors must be selected correctly for optimal performance.

An input capacitor is required for stability. A minimum 1 $\mu$ F capacitor must be connected between IN to GND for stable operation over the entire load current range. There can be more output capacitance than input as long as the input is at least 1 $\mu$ F.

The IC is designed specifically to work with a very small ceramic output capacitor (typically 2.2 $\mu$ F). A minimum 2.2 $\mu$ F ceramic capacitor with X5R or X7R type dielectrics is suitable in the MP2667 application circuit. The output capacitor should be connected between SYS and GND with thick traces and small loop area.

A capacitor from BATT to GND is also necessary for the MP2667, and the typical capacitance value is 10 $\mu$ F. A ceramic capacitor with X5R or X7R type dielectrics at least 10 $\mu$ F is suitable for the application circuit.

A capacitor between VDD and GND is used to stabilize the VDD voltage to power the internal control and logic circuit. The typical value of this capacitor is 100nF.

### PCB Layout Guidelines

Efficient PCB layout is critical for stable operation of the MP2667. For best results, follow the guidelines below:

1. Place the external capacitors as close to the IC as possible to ensure the smallest input inductance and ground impedance.
2. Place the PCB trace connecting the capacitor between VDD and GND as close as possible to the IC.
3. Keep the signal GND for the I<sup>2</sup>C wire clean.
4. Route the I<sup>2</sup>C wires (SDA and SCL) parallel with each other.

## TYPICAL APPLICATION CIRCUIT

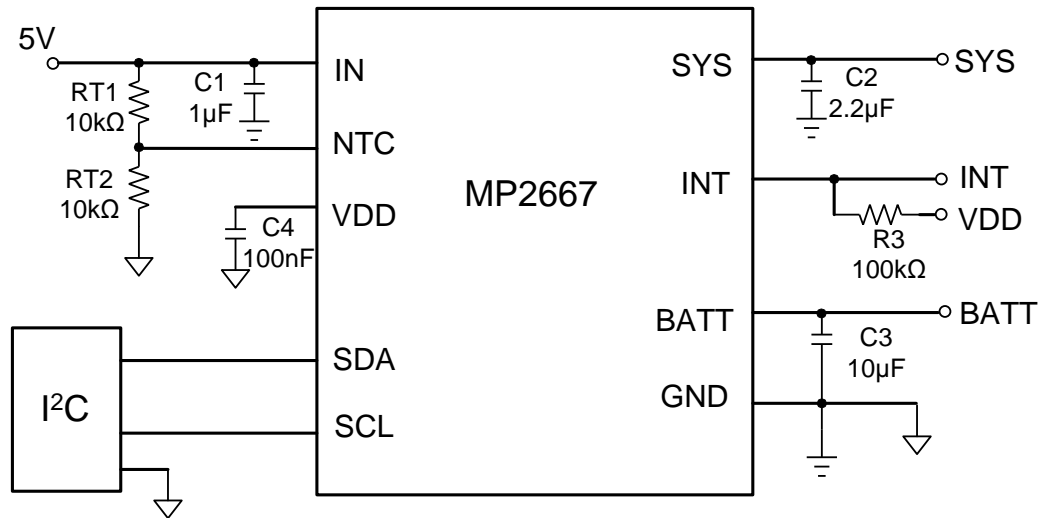

Figure 14: MP2667 Typical Application Circuit with 5V Input

Table 4: The Key BOM of Figure 14

Qty	Ref	Value	Description	Package	Manufacture
1	C1	1μF	Ceramic capacitor, 16V, X5R or X7R	0603	Any
1	C2	2.2μF	Ceramic capacitor, 16V, X5R or X7R	0603	Any
1	C3	10μF	Ceramic capacitor, 16V, X5R or X7R	0603	Any
1	C4	100nF	Ceramic capacitor, 16V, X5R or X7R	0603	Any
2	RT <sub>1</sub> , RT <sub>2</sub>	10kΩ	Film resistor, 1%	0603	Any

# PACKAGE INFORMATION

## QFN-10 (2mmx2mm)

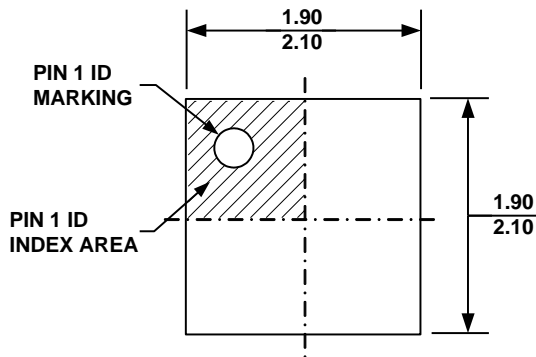

**TOP VIEW**

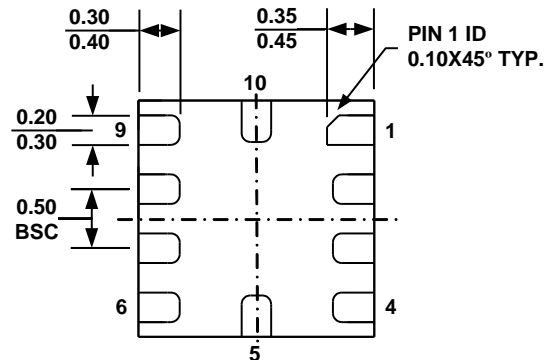

**BOTTOM VIEW**

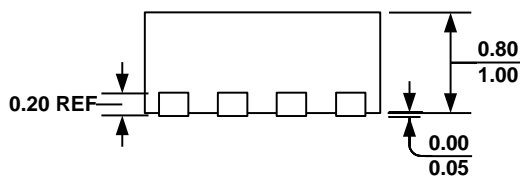

**SIDE VIEW**

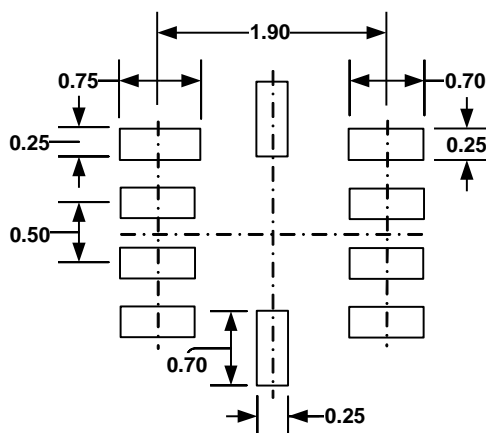

**RECOMMENDED LAND PATTERN**

**NOTE:**

- 1) ALL DIMENSIONS ARE IN MILLIMETERS.
- 2) EXPOSED PADDLE SIZE DOES NOT INCLUDE MOLD FLASH.
- 3) LEAD COPLANARITY SHALL BE 0.10 MILLIMETER MAX.
- 4) JEDEC REFERENCE IS MO-220, VARIATION VCCD.
- 5) DRAWING IS NOT TO SCALE.

**NOTICE:** The information in this document is subject to change without notice. Please contact MPS for current specifications. Users should warrant and guarantee that third-party Intellectual Property rights are not infringed upon when integrating MPS products into any application. MPS will not assume any legal responsibility for any said applications.

## X-ON Electronics

Largest Supplier of Electrical and Electronic Components

*Click to view similar products for [Battery Management](#) category:*

*Click to view products by [Monolithic Power Systems](#) manufacturer:*

Other Similar products are found below :

[NCP1851BFCCT1G](#) [NCP1855FCCT1G](#) [FAN54063UCX](#) [MP2615GQ-P](#) [LC05132C01NMTTGTG](#) [ISL95522HRZ](#) [BD8665GW-E2](#)  
[ISL9538HRTZ](#) [ISL95522AIRZ](#) [S-82D1AAA-A8T2U7](#) [S-8224ABA-I8T1U](#) [MP2615CGQ-P](#) [ISL6251HRZ](#) [ISL6253HRZ](#) [ISL6292-2CR3](#)  
[ISL6292BCRZ-T](#) [ISL6299AIRZ](#) [ISL9211AIRU58XZ-T](#) [ISL9214IRZ](#) [ISL9220IRTZ-T](#) [FAN54161UCX](#) [SY6982CQDC](#)  
[IP6566\\_AC\\_30W\\_ZM](#) [WS3221C-6/TR](#) [ADBMS1818ASWAZ-RL](#) [ADBMS6815WCSWZ](#) [ML5245-005AMBZ07CX](#) [BQ25672RQMR](#)  
[ADBMS1818ASWZ-R7](#) [KA49503A-BB](#) [SC33771CTA1MAE](#) [BQ24060DRCR](#) [BQ7695202PFBR](#) [BQ21080YBGR](#) [BQ771809DPJR](#)  
[BQ24179YBGR](#) [BQ7693002DBTR](#) [BQ25170DSGR](#) [TP4586](#) [FM2119L](#) [FM1623A](#) [DW01](#) [BQ25172DSGR](#) [DW01S](#) [TP4054](#) [MP2723GQC-](#)  
[0000-Z](#) [MP26124GR-Z](#) [MP2664GG-0000-Z](#) [MP26029GTF-0000-Z](#) [MP2695GQ-0000-Z](#)