

## DESCRIPTION

The MP28114 is a 1.7MHz constant frequency, current mode, ultra-small PWM step-down converter. The device integrates a main switch and a synchronous rectifier for high efficiency and eliminates the needs for an external schottky diode. It is ideal for powering portable equipment that runs from a single cell Lithium-Ion (Li+) battery. The MP28114 can supply 600mA of load current from a 2.5V to 6V input voltage. The output voltage for the MP28114DG can be regulated as low as 0.6V, while the output voltages of the MP28114DG-1.5, MP28114G-1.8, and MP28114DG-3.3 are fixed at 1.5V, 1.8V, and 3.3V, respectively. The MP28114 can also run at 100% duty cycle for low dropout applications. The MP28114 is available in an ultra-small 2x2mm QFN package.

## ORDERING INFORMATION

Part Number	Output Voltage
MP28114DG - 1.5	$V_{OUT} = 1.5V$
MP28114DG - 1.8	$V_{OUT} = 1.8V$
MP28114DG - 3.3	$V_{OUT} = 3.3V$
MP28114DG	$V_{OUT} = 0.6 \text{ to } 6V$

## FEATURES

- High Efficiency: Up to 95%
- 1.7MHz Constant Switching Frequency
- 600mA Available Load Current
- 2.5V to 6V Input Voltage Range
- Output Voltage as Low as 0.6V
- 100% Duty Cycle in Dropout
- Current Mode Control
- Short Circuit Protection
- Thermal Fault Protection
- $<0.1\mu A$  Shutdown Current
- 1.5V, 1.8V, and 3.3V Fixed Out-put Versions
- Ultra-Small 2x2mm QFN Package

## APPLICATIONS

- Cellular and Smart Phones
- Microprocessors and DSP Core Supplies
- PDAs
- MP3 Players
- Digital Still and Video Cameras
- Portable Instruments

"MPS" and "The Future of Analog IC Technology" are Registered Trademarks of Monolithic Power Systems, Inc.

## TYPICAL APPLICATION

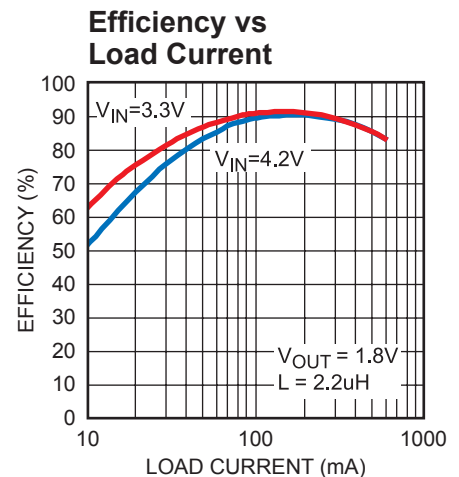
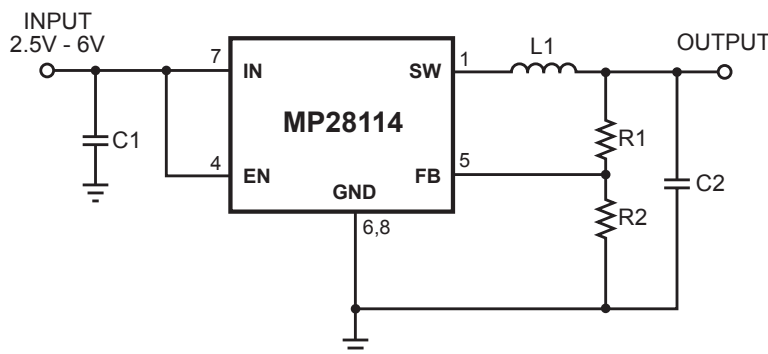

### ORDERING INFORMATION

Part Number	Package	Top Marking	Free Air Temperature (T <sub>A</sub> )
MP28114DG - 1.5	2 X 2mm QFN8	3D	-40°C to +85°C
MP28114DG - 1.8		2D	
MP28114DG - 3.3		AL	
MP28114DG*		4D	

\* For Tape & Reel, add suffix -Z (e.g. MP28114DG-Z).  
 For RoHS Compliant Packaging, add suffix -LF (e.g. MP28114DG-LF-Z)

### PACKAGE REFERENCE

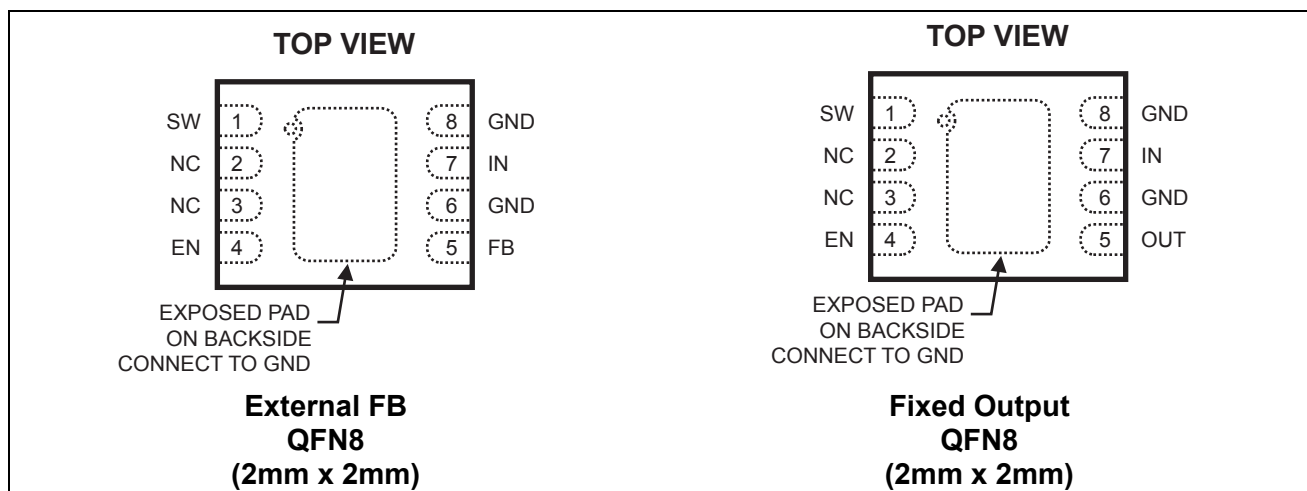

#### ABSOLUTE MAXIMUM RATINGS <sup>(1)</sup>

V <sub>IN</sub> to GND	-0.3V to +6.5V
V <sub>SW</sub> to GND	-0.3V to V <sub>IN</sub> +0.3V
V <sub>FB</sub> , V <sub>EN</sub> to GND	-0.3V to +6.5V
SW Peak Current	1.4A
Continuous Power Dissipation (T <sub>A</sub> = +25°C) <sup>(2)</sup>	1.56W
Junction Temperature	+150°C
Lead Temperature <sup>(3)</sup>	+260°C
Storage Temperature	-65°C to +150°C

#### Recommended Operating Conditions <sup>(4)</sup>

Supply Voltage V <sub>IN</sub>	2.5V to 6V
Output Voltage V <sub>OUT</sub>	0.6V to 6V
Operating Temperature	-40°C to +85°C

<b>Thermal Resistance <sup>(5)</sup></b>	<b>θ<sub>JA</sub></b>	<b>θ<sub>JC</sub></b>
2x2mm QFN8	80	16 ... °C/W

**Notes:**

- Exceeding these ratings may damage the device.
- The maximum allowable power dissipation is a function of the maximum junction temperature T<sub>J</sub>(MAX), the junction-to-ambient thermal resistance θ<sub>JA</sub>, and the ambient temperature T<sub>A</sub>. The maximum allowable continuous power dissipation at any ambient temperature is calculated by P<sub>D</sub>(MAX)=(T<sub>J</sub>(MAX)-T<sub>A</sub>)/θ<sub>JA</sub>. Exceeding the maximum allowable power dissipation will cause excessive die temperature, and the regulator will go into thermal shutdown. Internal thermal shutdown circuitry protects the device from permanent damage.
- For recommended IR reflow temperature information, refer to MPS document MP28114\_IRRTP.
- The device is not guaranteed to function outside of its operating conditions.
- Measured on JESD51-7 4-layer board.

**ELECTRICAL CHARACTERISTICS** <sup>(6)</sup> (continued)

 $V_{IN} = V_{EN} = 3.6V$ ,  $T_A = +25^{\circ}C$ , unless otherwise noted.

Parameter	Symbol	Condition	Min	Typ	Max	Units
Supply Current		$V_{EN} = V_{IN}$ , $V_{FB} = 0.65V$		400	600	$\mu A$
Shutdown Current		$V_{EN} = 0V$ , $V_{IN} = 6V$		0.01	1	$\mu A$
IN Under Voltage Lockout Threshold		Rising Edge	2.10	2.27	2.45	V
IN Under Voltage Lockout Hysteresis				55		mV
Regulated FB Voltage		$T_A = +25^{\circ}C$ , MP28114DG	0.588	0.600	0.612	V
		$-40^{\circ}C \leq T_A \leq +85^{\circ}C$	0.582	0.600	0.618	
FB Input Bias Current		$V_{FB} = 0.65V$ , MP28114DG	-50	0.5	+50	nA
Regulated Output Voltage		MP28114DG-1.5 $I_{OUT} = 50mA$ $-40^{\circ}C \leq T_A \leq +85^{\circ}C$	1.455	1.500	1.545	V
		MP28114DG-1.8 $I_{OUT} = 50mA$ $-40^{\circ}C \leq T_A \leq +85^{\circ}C$	1.746	1.800	1.854	
		MP28114DG-3.3 $I_{OUT} = 50mA$ $-40^{\circ}C \leq T_A \leq +85^{\circ}C$	3.201	3.300	3.399	
PFET On Resistance		$I_{SW} = 100mA$		0.44		$\Omega$
NFET On Resistance		$I_{SW} = -100mA$		0.29		$\Omega$
SW Leakage Current		$V_{EN} = 0V$ , $V_{IN} = 6V$ $V_{SW} = 0V$ or $6V$	-1		+1	$\mu A$
PFET Current Limit		Duty Cycle = 100%, Current Pulse Width < 1ms	0.7	1.0	1.35	A
Oscillator Frequency			1.26	1.70	2.08	MHz
Thermal Shutdown Trip Threshold				145		$^{\circ}C$
EN Trip Threshold		$-40^{\circ}C \leq T_A \leq +85^{\circ}C$	0.3	0.96	1.5	V
EN Input Current		$V_{EN} = 0V$ to $6V$	-1		+1	$\mu A$

**Notes:**

 6) 100% production test at  $+25^{\circ}C$ . Typical and temperature specifications are guaranteed by design and characterization.

## PIN FUNCTIONS

Pin #	Name	Description
1	SW	Power Switch Output. Inductor connection to drains of the internal PFET and NFET switches.
2, 3	NC	No Connect
4	EN	Regulator Enable Control Input. Drive EN above 1.5V to turn on the MP28114. Drive EN below 0.3V to turn it off (shutdown current < 0.1 $\mu$ A).
5	FB	Feedback Input. Connect FB to the center point of the external resistor divider. The feedback threshold voltage is 0.6V.
5	OUT	Output Voltage Sense Input (MP28114DG-1.5, MP28114DG-1.8 and MP28114DG-3.3). An internal resistor divider is connected to this pin to set the proper output voltage.
6, 8	GND, Exposed Pad	Ground. Connect exposed pad to GND plane for optimal thermal performance.
7	IN	Supply Input. Bypass to GND with a 2.2 $\mu$ F or greater ceramic capacitor.

## TYPICAL PERFORMANCE CHARACTERISTICS

$V_{IN} = 3.3V$ ,  $V_{OUT} = 1.8V$ ,  $L1 = 10\mu H$ ,  $C1 = 4.7\mu F$ ,  $C3 = 10\mu F$ ,  $T_A = +25^\circ C$ , unless otherwise noted.

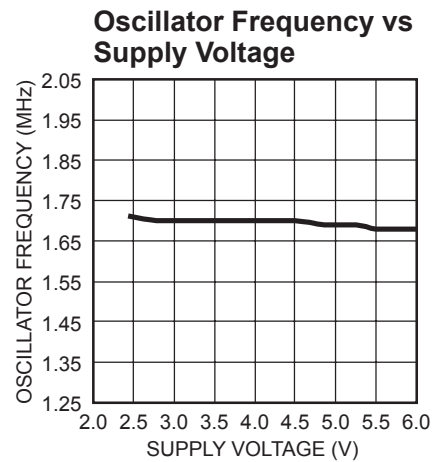
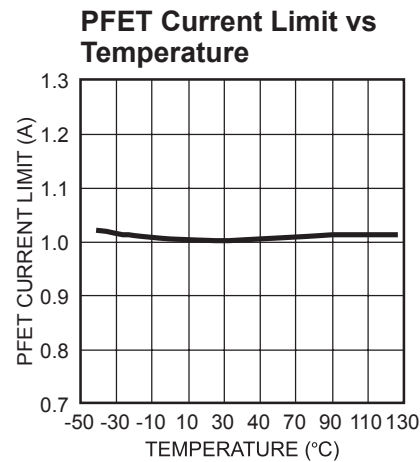
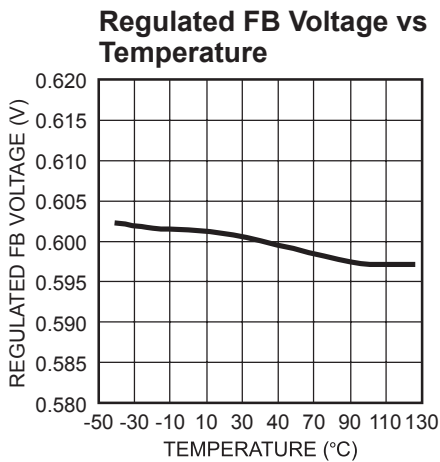
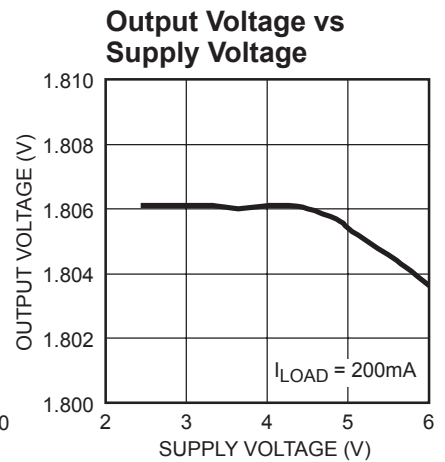
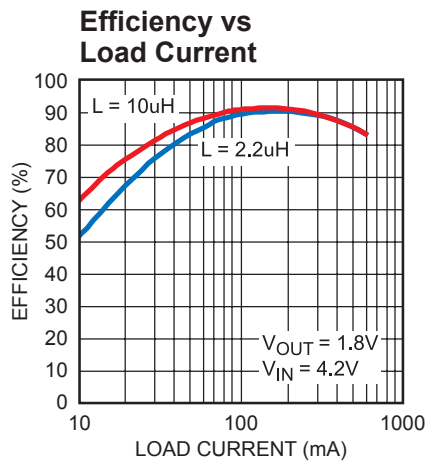
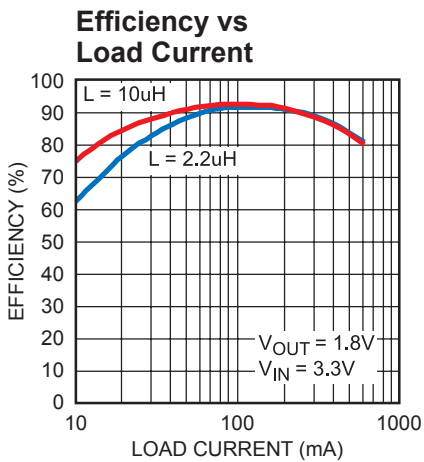
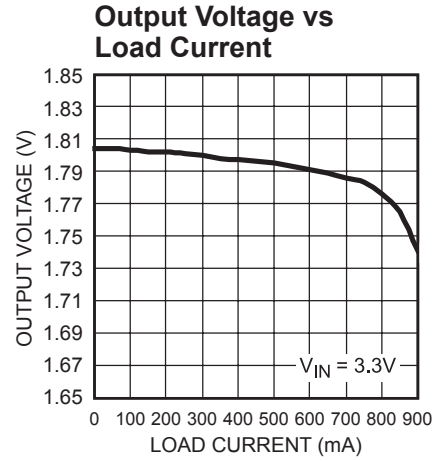
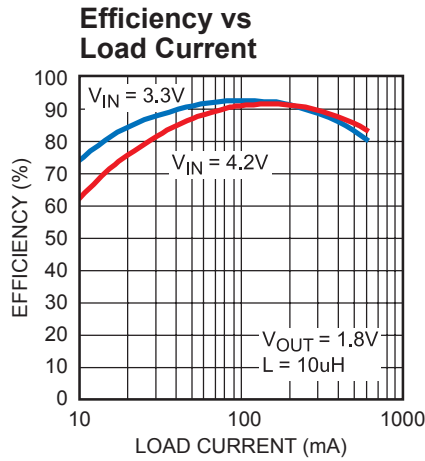
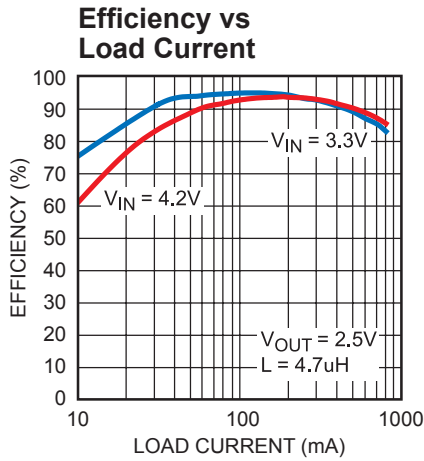

**TYPICAL PERFORMANCE CHARACTERISTICS** (continued)

$V_{IN} = 3.3V$ ,  $V_{OUT} = 1.8V$ ,  $L1 = 10\mu H$ ,  $C1 = 4.7\mu F$ ,  $C3 = 10\mu F$ ,  $T_A = +25^\circ C$ , unless otherwise noted.

**Load Transient**

$V_{IN} = 3.3V$ ,  $V_{OUT} = 1.8V$ ,  
 $I_{LOAD} = 0 - 500mA$  Step

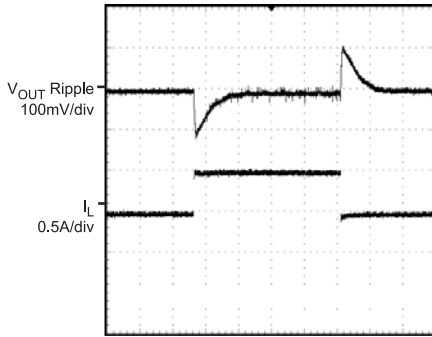

20µs/div

**Light Load Operation**

$V_{IN} = 3.3V$ ,  $V_{OUT} = 1.8V$ ,  
 $I_{LOAD} = 0A$

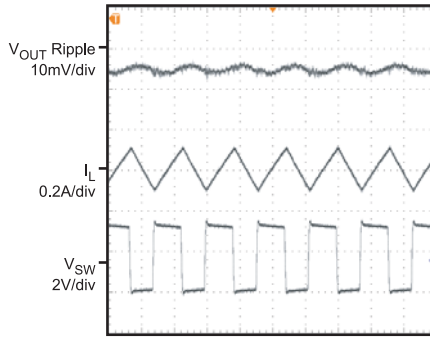

0.4µs/div

**Heavy Load Operation**

$V_{IN} = 3.3V$ ,  $V_{OUT} = 1.8V$ ,  
 $I_{LOAD} = 600mA$

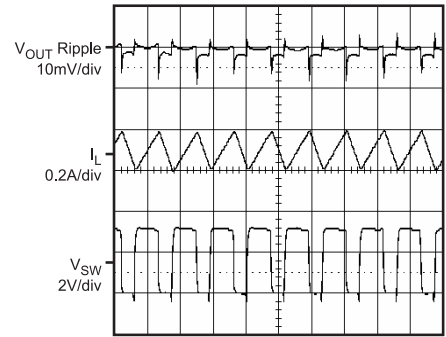

0.4µs/div

**Startup from Shutdown**

$V_{IN} = 2.5V$ ,  $V_{OUT} = 1.8V$ ,  
 $I_{LOAD} = 600mA$  Resistive

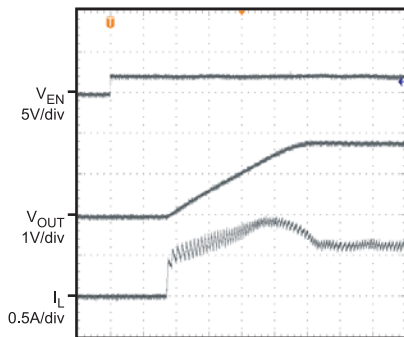

10µs/div

**Startup from Shutdown**

$V_{IN} = 3.3V$ ,  $V_{OUT} = 1.8V$ ,  
 $I_{LOAD} = 600mA$  Resistive

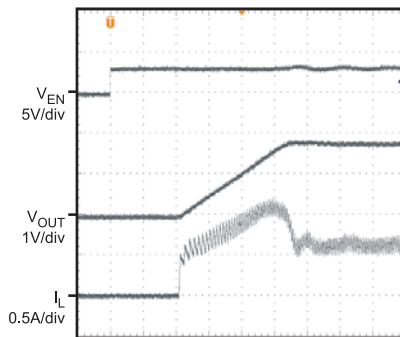

10µs/div

**Startup from Shutdown**

$V_{IN} = 5V$ ,  $V_{OUT} = 1.8V$ ,  
 $I_{LOAD} = 600mA$  Resistive

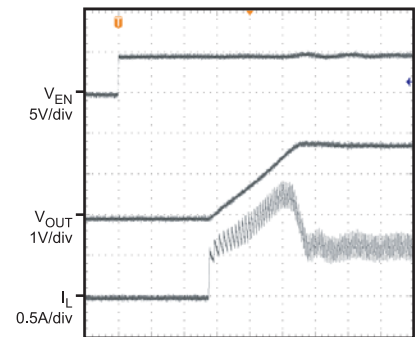

10µs/div

**Short Circuit Protection**

$V_{IN} = 3.3V$ ,  $V_{OUT} = 1.8V$ ,  
No Load

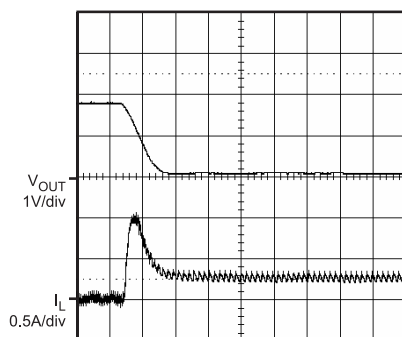

10µs/div

**Short Circuit Recovery**

$V_{IN} = 3.3V$ ,  $V_{OUT} = 1.8V$ ,  
No Load

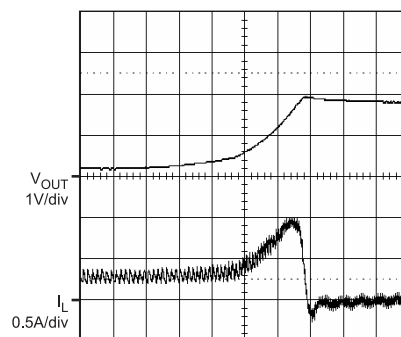

10µs/div

## OPERATION

The MP28114 is a constant frequency current mode PWM step-down converter. The MP28114 is optimized for low voltage, Li-Ion battery powered applications where high efficiency and small size are critical. The MP28114 uses an external resistor divider to set the output voltage from 0.6V to 6V. The device integrates both a main switch and a synchronous rectifier, which provides high efficiency and eliminates an external Schottky

diode. The MP28114 can achieve 100% duty cycle. The duty cycle  $D$  of a step-down converter is defined as:

$$D = T_{ON} \times f_{OSC} \times 100\% \approx \frac{V_{OUT}}{V_{IN}} \times 100\%$$

Where  $T_{ON}$  is the main switch on time,  $f_{OSC}$  is the oscillator frequency (1.7MHz),  $V_{OUT}$  is the output voltage and  $V_{IN}$  is the input voltage.

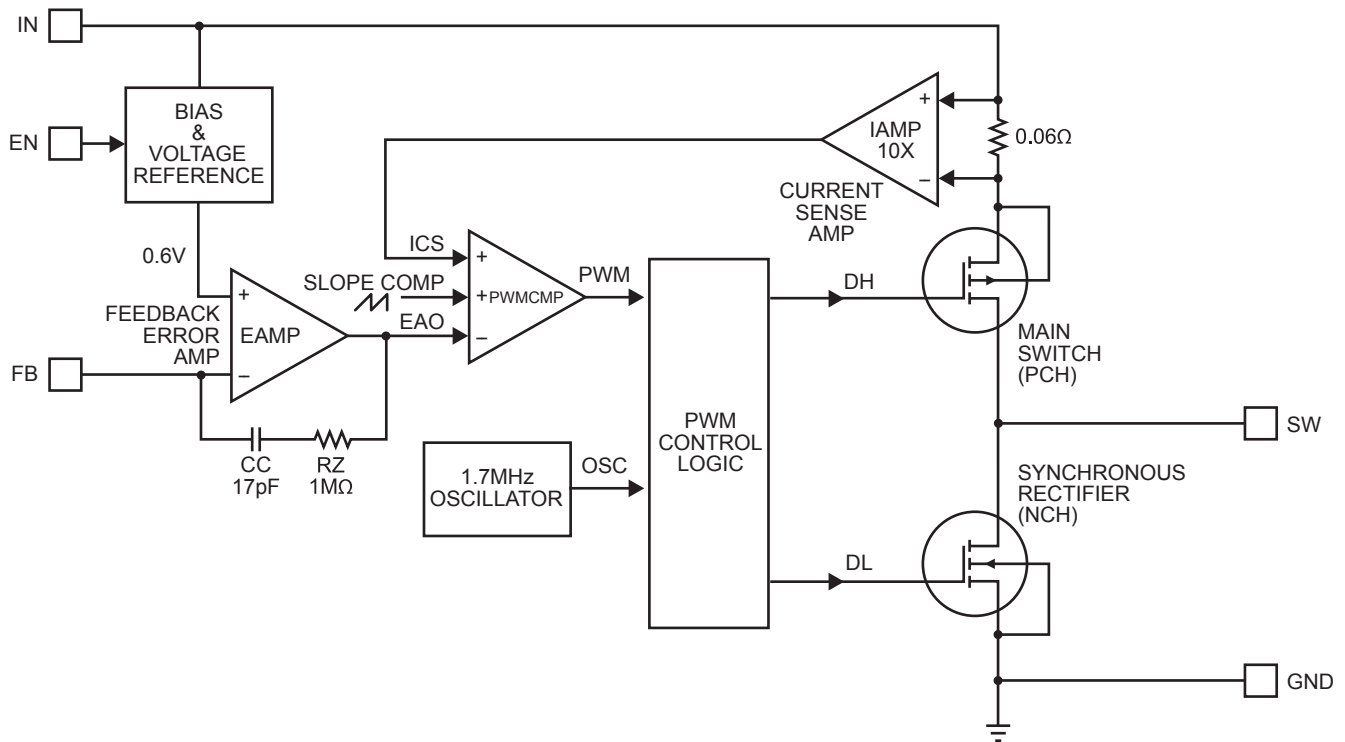

**Figure 1—Functional Block Diagram (MP28114)**

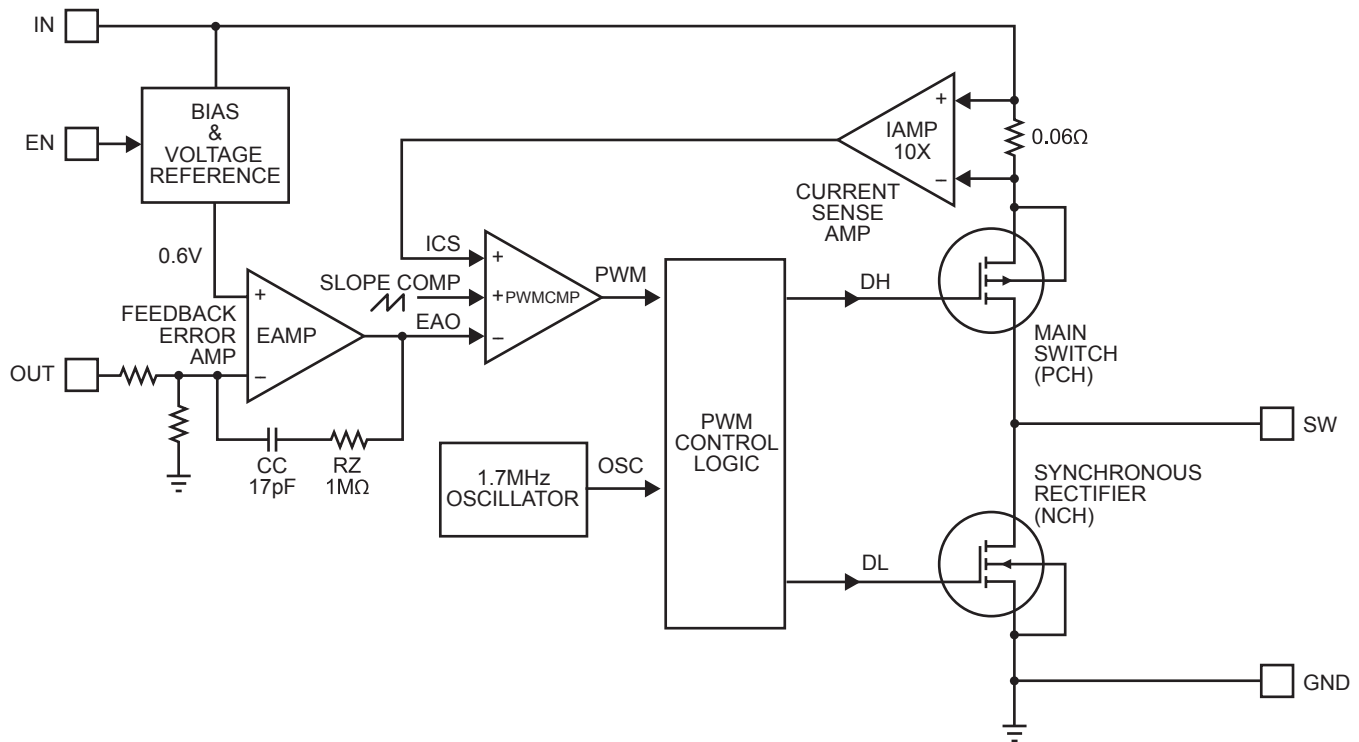

**Figure 2—Functional Block Diagram**

(MP28114DG-1.5 MP28114DG-1.8/ MP28114DG-3.3)

### Current Mode PWM Control

Slope compensated current mode PWM control provides stable switching and cycle-by-cycle current limit for superior load and line response and protection of the internal main switch and synchronous rectifier. The MP28114 switches at a constant frequency (1.7MHz) and regulates the output voltage. During each cycle the PWM comparator modulates the power transferred to the load by changing the inductor peak current based on the feedback error voltage. During normal operation, the main switch is turned on for a certain time to ramp the inductor current at each rising edge of the internal oscillator, and switched off when the peak inductor current is above the error voltage. When the main switch is off, the synchronous rectifier will be turned on immediately and stay on until either the next cycle starts.

### Dropout Operation

The MP28114 allows the main switch to remain on for more than one switching cycle and increases the duty cycle while the input voltage is dropping close to the output voltage. When the duty cycle reaches 100%, the main switch is held on continuously to deliver current to the output up

to the PFET current limit. The output voltage then is the input voltage minus the voltage drop across the main switch and the inductor.

### Short Circuit Protection

The MP28114 has short circuit protection. When the output is shorted to ground, the oscillator frequency is reduced to prevent the inductor current from increasing beyond the PFET current limit. The PFET current limit is also reduced to lower the short circuit current. The frequency and current limit will return to the normal values once the short circuit condition is removed and the feedback voltage reaches 0.6V.

### Maximum Load current

The MP28114 can operate down to 2.5V input voltage, however the maximum load current decreases at lower input due to large IR drop on the main switch and synchronous rectifier. The slope compensation signal reduces the peak inductor current as a function of the duty cycle to prevent sub-harmonic oscillations at duty cycles greater than 50%. Conversely the current limit increases as the duty cycle decreases.



## APPLICATION INFORMATION

### Output Voltage Setting (MP28114DG)

The external resistor divider sets the output voltage (see Figure 3). The feedback resistor R1 also sets the feedback loop bandwidth with the internal compensation capacitor (see Figure 1).

Choose R1 around 300kΩ for optimal transient response. R2 is then given by:

$$R2 = \frac{R1}{\frac{V_{OUT}}{0.6V} - 1}$$

**Table 1—Resistor Selection vs. Output Voltage Setting**

V <sub>OUT</sub>	R1	R2
1.8V	300kΩ (1%)	150kΩ (1%)
2.5V	300kΩ (1%)	95.3kΩ (1%)

### Inductor Selection

A 1μH to 10μH inductor with DC current rating at least 25% higher than the maximum load

current is recommended for most applications. For best efficiency, the inductor DC resistance shall be <200mΩ. See Table 2 for recommended inductors and manufacturers. For most designs, the inductance value can be derived from the following equation:

$$L = \frac{V_{OUT} \times (V_{IN} - V_{OUT})}{V_{IN} \times \Delta I_L \times f_{OSC}}$$

Where ΔI<sub>L</sub> is the inductor ripple current. Choose inductor ripple current approximately 30% of the maximum load current, 600mA.

The maximum inductor peak current is:

$$I_{L(MAX)} = I_{LOAD} + \frac{\Delta I_L}{2}$$

Under light load conditions below 100mA, larger inductance is recommended for improved efficiency. Table 3 lists inductors recommended for this purpose.

**Table 2—Suggested Surface Mount Inductors**

Manufacturer	Part Number	Inductance (μH)	Max DCR (Ω)	Saturation Current (A)	Dimensions LxWxH (mm <sup>3</sup> )
Coilcraft	LP1704-222M	2.2	0.07	1.7	6.5x5.3x2
Toko	D312C	2.2	0.14	1.0	3.6x3.6x1
Taiyo Yuden	LBC2518	2.2	0.13	0.6	2.5x1.8x1.8

**Table 3—Inductors for Improved Efficiency at 25mA, 50mA, under 100mA Load.**

Manufacturer	Part Number	Inductance (μH)	Max DCR (Ω)	Saturation Current (A)	I <sub>RMS</sub> (A)
Coilcraft	DO1605T-103MX	10	0.3	1.0	0.9
Murata	LQH4C100K04	10	0.2	1.2	0.8

### Input Capacitor Selection

The input capacitor reduces the surge current drawn from the input and switching noise from the device. The input capacitor impedance at the switching frequency shall be less than input source impedance to prevent high frequency switching current passing to the input. Ceramic capacitors with X5R or X7R dielectrics are highly recommended because of their low ESR and small temperature coefficients. For most applications, a 4.7μF capacitor is sufficient.

### Output Capacitor Selection

The output capacitor keeps output voltage ripple small and ensures regulation loop stable. The output capacitor impedance shall be low at the switching frequency. Ceramic capacitors with X5R or X7R dielectrics are recommended. The output ripple ΔV<sub>OUT</sub> is approximately:

$$\Delta V_{OUT} \leq \frac{V_{OUT} \times (V_{IN} - V_{OUT})}{V_{IN} \times f_{OSC} \times L} \times \left( ESR + \frac{1}{8 \times f_{OSC} \times C3} \right)$$

## PCB LAYOUT GUIDE

PCB layout is very important to achieve stable operation. It is highly recommended to duplicate EVB layout for optimum performance.

If change is necessary, please follow these guidelines and take Figure 3 for reference.

- 1) Keep the path of switching current short and minimize the loop area formed by Input cap, high-side MOSFET and low-side MOSFET.
- 2) Bypass ceramic capacitors are suggested to be put close to the Vin Pin.
- 3) Place the external feedback resistors as close to the FB pin as possible.
- 4) Route SW away from sensitive analog areas such as FB.
- 5) Connect IN, SW, and especially GND respectively to a large copper area to cool the chip to improve thermal performance and long-term reliability.

For the fixed output versions (MP28114DG-1.5, MP28114-1.8, and MP28114DG-3.3), R1 is shorted and R2 is open.

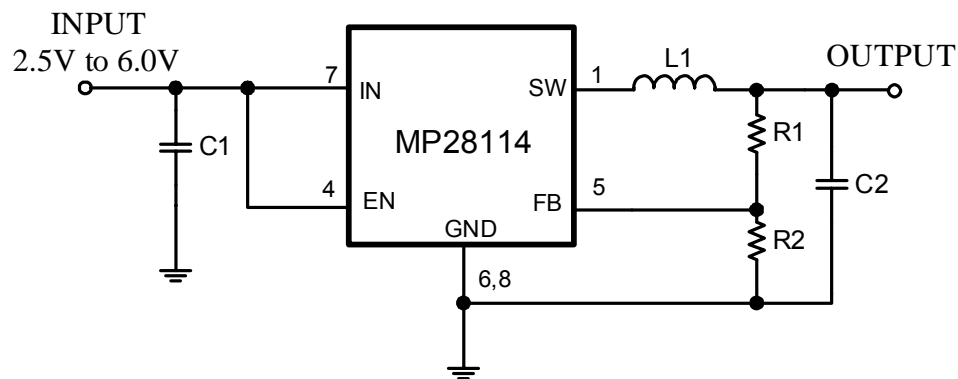

**MP28114 Typical Application Circuit**

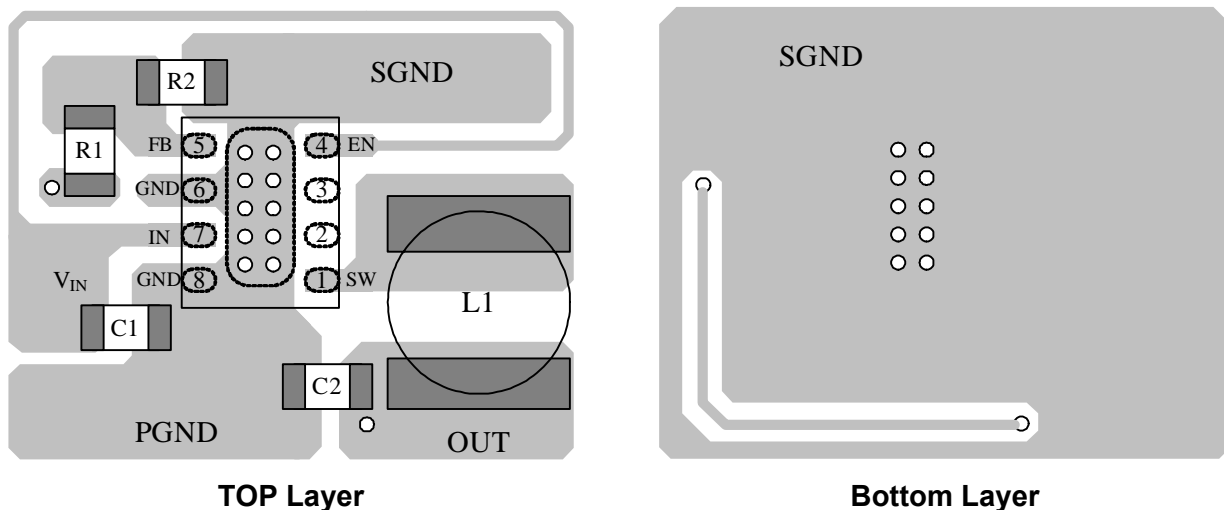

**Figure 3—MP28114 Typical Application Circuit and PCB Layout Guide**

**PACKAGE INFORMATION**

**2mm x 2mm QFN8**

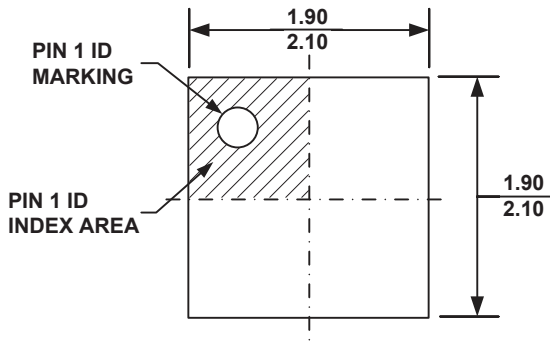

**TOP VIEW**

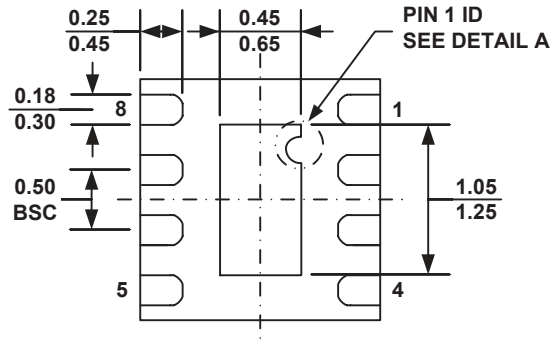

**BOTTOM VIEW**

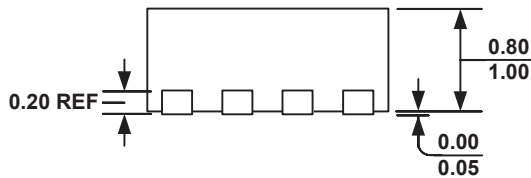

**SIDE VIEW**

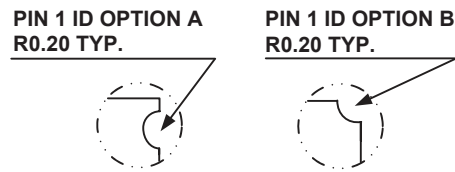

**DETAIL A**

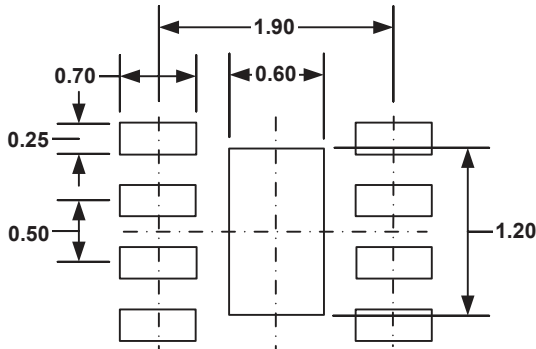

**RECOMMENDED LAND PATTERN**

**NOTE:**

- 1) ALL DIMENSIONS ARE IN MILLIMETERS.
- 2) EXPOSED PADDLE SIZE DOES NOT INCLUDE MOLD FLASH.
- 3) LEAD COPLANARITY SHALL BE 0.10 MILLIMETER MAX.
- 4) DRAWING CONFORMS TO JEDEC MO-229, VARIATION VCCD-3.
- 5) DRAWING IS NOT TO SCALE.

**NOTICE:** The information in this document is subject to change without notice. Users should warrant and guarantee that third party Intellectual Property rights are not infringed upon when integrating MPS products into any application. MPS will not assume any legal responsibility for any said applications.

## X-ON Electronics

Largest Supplier of Electrical and Electronic Components

*Click to view similar products for [Switching Voltage Regulators](#) category:*

*Click to view products by [Monolithic Power Systems](#) manufacturer:*

Other Similar products are found below :

[FAN53610AUC33X](#) [FAN53611AUC123X](#) [FAN48610BUC33X](#) [FAN48610BUC45X](#) [FAN48617UC50X](#) [R3](#) [430464BB](#) [KE177614](#)  
[MAX809TTR](#) [NCV891234MW50R2G](#) [NCP81103MNTXG](#) [NCP81203PMNTXG](#) [NCP81208MNTXG](#) [NCP81109GMNTXG](#)  
[SCY1751FCCT1G](#) [NCP81109JMNTXG](#) [AP3409ADNTR-G1](#) [NCP81241MNTXG](#) [LTM8064IY](#) [LT8315EFE#TRPBF](#) [NCV1077CSTBT3G](#)  
[XCL207A123CR-G](#) [MPM54304GMN-0002](#) [MPM54304GMN-0003](#) [XDPE132G5CG000XUMA1](#) [MP8757GL-P](#) [MIC23356YFT-TR](#)  
[LD8116CGL](#) [HG2269M/TR](#) [OB2269](#) [XD3526](#) [U6215A](#) [U6215B](#) [U6620S](#) [LTC3803ES6#TR](#) [LTC3803ES6#TRM](#) [LTC3412IFE](#) [LT1425IS](#)  
[MAX25203BATJA/VY+](#) [MAX77874CEWM+](#) [XC9236D08CER-G](#) [ISL95338IRTZ](#) [MP3416GJ-P](#) [BD9S201NUX-CE2](#) [MP5461GC-Z](#)  
[MPQ4415AGQB-Z](#) [MPQ4590GS-Z](#) [MCP1603-330IMC](#) [MCP1642B-18IMC](#) [MCP1642D-ADJIMC](#)