



The Future of Analog IC Technology®

MP4030A

TRIAC-Dimmable, Primary-Side-Control Offline LED Controller with Active PFC

DESCRIPTION

The MP4030A is a TRIAC-dimmable, primary-side-control, offline LED lighting controller with active PFC. It can output an accurate LED current for an isolated lighting application with a single-stage converter. The proprietary real-current-control method can accurately control the LED current using primary-side information. It can significantly simplify LED lighting system design by eliminating secondary-side feedback components and the optocoupler.

The MP4030A implements power-factor correction and works in boundary-conduction mode to reduce MOSFET switching losses.

The MP4030A has an integrated charging circuit at the supply pin for fast start-up without a perceptible delay.

The proprietary dimming control expands the TRIAC-based dimming range.

The MP4030A features multiple protections including over-voltage protection (OVP), short-circuit protection (SCP), primary-side over-current protection (OCP), supply-pin under-voltage lockout (UVLO), and over temperature protection (OTP). All of which not only simplifies circuit design but also enhances system reliability and safety greatly. All fault protections feature auto-restart.

The MP4030A is available in an 8-pin SOIC package.

FEATURES

- Primary-Side-Control without Requiring a Secondary-Side Feedback Circuit
- Internal Charging Circuit at the Supply Pin for Fast Start-Up
- Accurate Line & Load Regulation
- High Power Factor and Improved THD
- Flicker-Free, Phase-Controlled TRIAC Dimming with Expanded Dimming Range 1% to 100% Full Range
- Operates in Boundary Conduction Mode
- Cycle-by-Cycle Current Limit
- Primary-Side, Over-Current Protection
- Over-Voltage Protection
- Short-Circuit Protection
- Over-Temperature Protection
- Available in an 8-Pin SOIC Package

APPLICATIONS

- Solid-State Lighting, including:
 - Industrial and Commercial Lighting
 - Residential Lighting

All MPS parts are lead-free and adhere to the RoHS directive. For MPS green status, please visit MPS website under Products, Quality Assurance page. "MPS" and "The Future of Analog IC Technology" are registered trademarks of Monolithic Power Systems, Inc.

TYPICAL APPLICATION

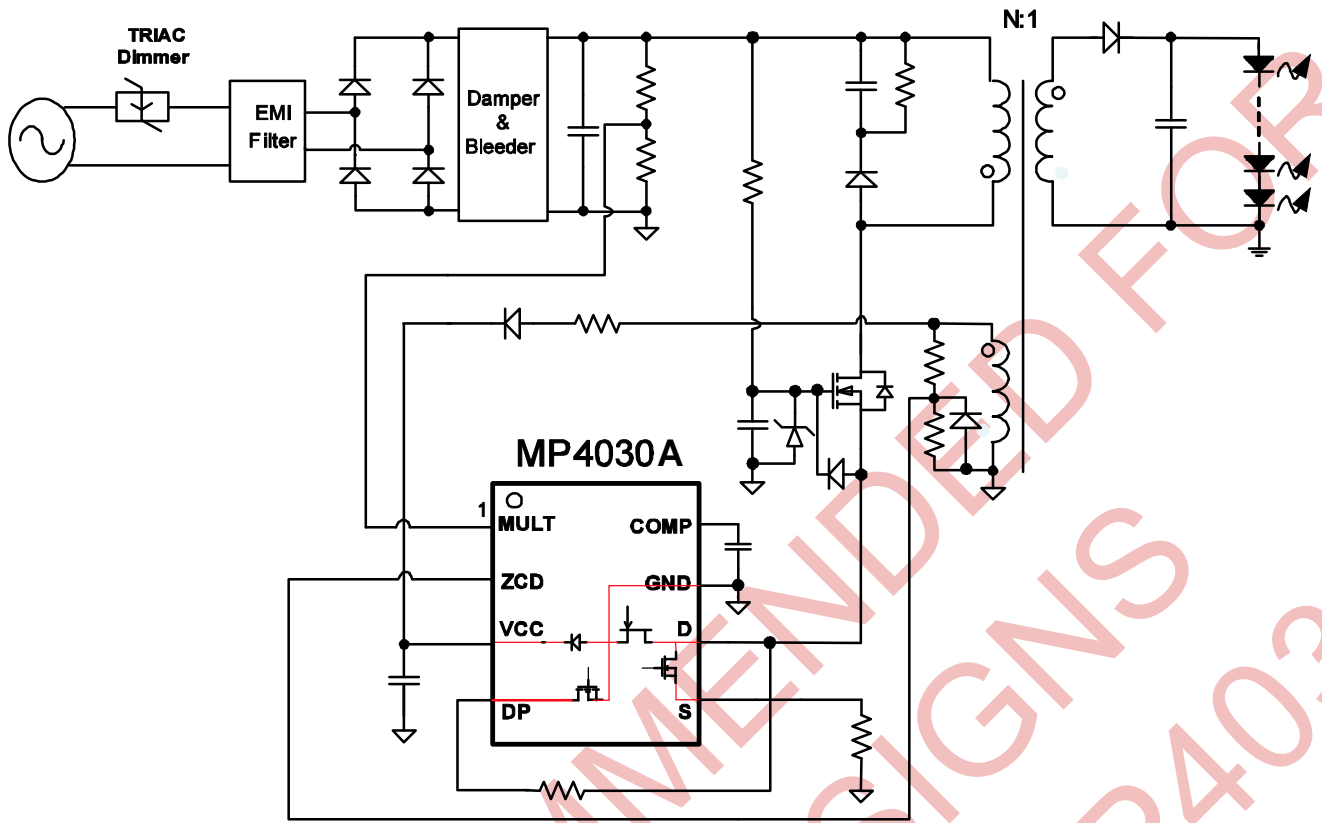

NOT RECOMMENDED FOR NEW DESIGNS REFER TO MP4033

ORDERING INFORMATION

Part Number*	Package	Top Marking
MP4030AGS	SOIC8	MP4030A

* For Tape & Reel, add suffix --Z (e.g. MP4030AGS--Z);

PACKAGE REFERENCE

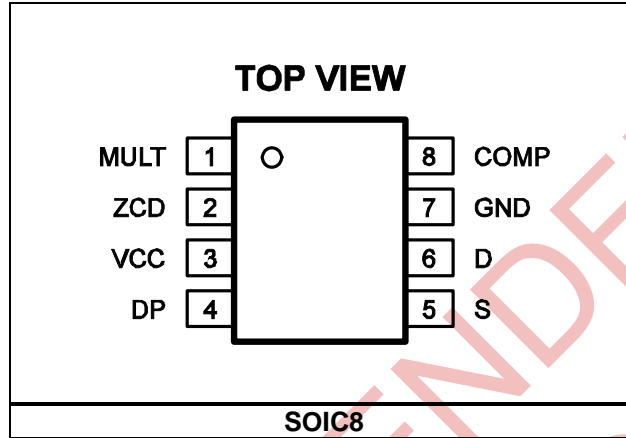

ABSOLUTE MAXIMUM RATINGS ⁽¹⁾

VCC Pin Voltage	-0.3V to +30V
Low-Side MOSFET Drain Voltage	-0.3V to +30V
ZCD Pin Voltage	-8V to +7V
Other Analog Inputs and Outputs	-0.3V to 7V
ZCD Pin Current	-5mA to +5mA
Continuous Power Dissipation ⁽²⁾	(T _A = +25°C)
SOIC8	1.3W
Junction Temperature	150°C
Lead Temperature	260°C
Storage Temperature	-65°C to +150°C

Recommended Operating Conditions ⁽³⁾

VCC Pin Voltage	11V to 27V
Operating Junction Temp (T _J)	-40°C to +125°C

Thermal Resistance ⁽⁴⁾

	θ_{JA}	θ_{JC}
SOIC8	96	45

Notes:

- Exceeding these ratings may damage the device.
- The maximum allowable power dissipation is a function of the maximum junction temperature T_J(MAX), the junction-to-ambient thermal resistance θ_{JA} , and the ambient temperature T_A. The maximum allowable continuous power dissipation at any ambient temperature is calculated by P_D(MAX)=(T_J(MAX)-T_A)/ θ_{JA} . Exceeding the maximum allowable power dissipation will cause excessive die temperature, and the regulator will go into thermal shutdown. Internal thermal shutdown circuitry protects the device from permanent damage.
- The device is not guaranteed to function outside of its operation conditions.
- Measured on JESD51-7 4-layer board.

ELECTRICAL CHARACTERISTICS

$T_A = +25^\circ\text{C}$, unless otherwise noted.

Parameter	Symbol	Condition	Min	Typ	Max	Units
Supply Voltage						
Operating Range	V_{CC}	After turn on	10		27	V
V_{CC} Upper Level: Internal Charging Circuit Stops and IC Turns On	V_{CCH}		9.4	10	10.5	V
V_{CC} Lower Level: Internal Charging Circuit Triggers	V_{CCL}		8.65	9	9.55	V
V_{CC} Re-charge and IC turns off Level in Fault Condition	V_{CCEN}	Fault condition	6.55	7	7.45	V
Supply Current						
VCC Charging Current from D	I_{D_Charge}	$V_D=16\text{V}$, $V_{CC}=5\text{V}$	12.5	15	17.5	mA
Quiescent Current	I_Q	No switching, $V_{CC}=15\text{V}$		800	1000	μA
Quiescent Current at Fault	I_{Q_Fault}	Fault condition, IC latch, $V_{CC}=15\text{V}$	160	220	300	μA
Operating Current	I_{CC}	$f_s = 70\text{kHz}$, $V_{CC}=15\text{V}$		1	2	mA
Multiplier						
Linear Operation Range	V_{MULT}	V_{COMP} from 1.9V to 4.9V	0		3	V
Gain	$K^{(5)}$	$V_{COMP}=2\text{V}$, $V_{MULT}=0.5\text{V}$	0.82	1.04	1.24	1/V
		$V_{COMP}=2\text{V}$, $V_{MULT}=1.5\text{V}$	0.86	1.05	1.20	1/V
		$V_{COMP}=2\text{V}$, $V_{MULT}=3\text{V}$	0.91	1.06	1.24	1/V
TRIAC-Dimming OFF Detection Threshold	V_{MUL_OFF}		0.13	0.15	0.17	V
TRIAC-Dimming ON Detection Threshold	V_{MUL_ON}		0.32	0.35	0.38	V
TRIAC-Dimming OFF Line-Cycle Blanking Ratio	D_{OFF_LEB}			25		%
TRIAC Dimming Threshold, Duty-Cycle Ratio to Disable DP			74.4	75	75.4	%
TRIAC Dimming Hysteresis, Duty-Cycle Ratio to Disable DP			4.6	5.3	6.0	%
Dimming Pull-Down MOSFET Turn-ON Threshold	$V_{MULT_DP_ON}$		0.22	0.25	0.28	V
Dimming Pull-Down MOSFET Turn-OFF Delay Time	$t_{DP_OFF_Delay}$	Starts at the rising edge of $V_{MULT}=V_{MULT_ON}$	150	200	250	μs
Error Amplifier						
Reference Voltage	V_{REF}		0.388	0.403	0.417	V
Transconductance	G_{EA}			150		$\mu\text{A/V}$
COMP Lower Clamp Voltage	V_{COMPL}		1.85	1.9	1.96	V
Max. Source Current	I_{COMP+}			55		μA
Max. Sink Current without Dimmer	I_{COMP-}			-270		μA

ELECTRICAL CHARACTERISTICS (continued)
T_A = +25°C, unless otherwise noted.

Parameter	Symbol	Condition	Min	Typ	Max	Units
Sink Current at TRIAC Dimming OFF	I _{Sink_Dim}		60	70	80	μA
Current Sense Comparator						
Leading-Edge-Blanking Time	t _{LEB}		575	685	795	ns
Leading-Edge-Blanking Time for OCP	t _{LEB_OCP}			0.7		t _{LEB}
OCP Threshold	V _{OCP}		2.63	2.73	2.83	V
Current-Sense Upper Clamp Voltage	V _{S_Clamp_H}		2.2	2.3	2.4	V
Current-Sense Lower Clamp Voltage	V _{S_Clamp_L}		0.08	0.1	0.13	V
Zero-Current Detector						
Zero-Current Detection Threshold	V _{ZCD_T}	Falling Edge	0.32	0.35	0.38	V
Zero-Current Detection Hysteresis	V _{ZCD_HY}		510	550	590	mV
Zero-Current Detection LEB	t _{ZCD_LEB}	Starts at Gate Turn Off, V _S ≥ 0.25	1.8	2.5	3.1	μs
		Starts at Gate Turn Off, V _S < 0.25	0.85	1.2	1.5	μs
Over-Voltage Threshold	V _{ZCD_OVP}		5.1	5.4	5.7	V
OVP Detect LEB	t _{OVP_LEB}	Starts at Gate Turn Off	1.35	1.85	2.35	μs
Minimum OFF Time	t _{OFF_MIN}		3.6	5.1	6.6	μs
Starter						
Start Timer Period	T _{Start}		90	115	140	μs
Internal Main MOSFET						
Breakdown Voltage	BV _{DSS_Main}	V _{GS} =0	30			V
Drain-Source On-Resistor	R _{DS(ON)_Main}	I _D =100mA	200	260	320	mΩ
Internal Fault Pull Up MOSFET						
Breakdown Voltage	BV _{DSS_D-VCC}	V _{GS} =0	30			V
Continue Drain Current	I _{D_D-VCC}			12		mA
Internal Dimming Pull Down MOSFET						
Breakdown Voltage	BV _{DSS_DP}	V _{GS} =0	30			V
Drain-Source On-Resistor	R _{DS(ON)_DP}	I _D =50mA	24	28	32	Ω
Thermal Shutdown						
Thermal Shutdown Threshold	T _{SD}	Guaranteed by Characterization		150		°C
Thermal Shutdown Recovery Hysteresis	T _{HYS}	Guaranteed by Characterization		30		°C

Notes:

 5) The multiplier output is given by: $V_S = K \cdot V_{MULT} \cdot (V_{COMP} - 1.5)$

PIN FUNCTIONS

Pin #	Name	Pin Function
1	MULT	Internal Multiplier Input. Connect to the tap of resistor divider from the rectified voltage of the AC line. The half-wave sinusoidal signal provides a reference signal for the internal current-control loop. MULT also detects the TRIAC-dimming phase.
2	ZCD	Zero-Current Detection. A negative going-edge triggers the internal MOSFET's turn-on signal. Connect to the tap of a resistor divider from the auxiliary winding to GND. The ZCD pin can also detect over-voltage. Over-voltage occurs if V_{ZCD} exceeds the OVP threshold after a 1.85 μ s blanking time when the internal MOSFET turns off.
3	VCC	Supply Voltage. Supplies power for both the control signal and the internal MOSFET's gate driver. Connect to an external bulk capacitor - typically 22 μ F with a 100pF ceramic capacitor to reduce noise.
4	DP	Dimming Pull-Down. Drain of the internal dimming pull-down MOSFET. Connect a resistor from this pin to the D pin to pull down the rectified input voltage during the TRIAC dimming OFF interval.
5	S	Internal Low-Side Main MOSFET Source. Connect a resistor from this pin to GND to sense the internal MOSFET current. An internal comparator compares the resulting voltage to the internal sinusoid shaped current reference signal to determine when the MOSFET turns off. If the voltage exceeds the current-limit threshold of 2.3V after the leading edge blanking time during the turn-on interval, the gate signal turns off. Over-current occurs if V_s exceeds 2.73V during the turn-on interval after the leading-edge blanking time for OCP.
6	D	Internal Low-Side Main MOSFET Drain. Internally connects to VCC via a diode and a JFET to form an internal charging circuit for V_{CC} . Connect to the source of the high-side MOSFET. An internal MOSFET pulls up the D to VCC through a diode at fault condition to turn off the main switch.
7	GND	Ground. Current return of the control signal and the gate drive signal.
8	COMP	Loop Compensation. Connects to a compensation network to stabilize the LED driver and accurately control the LED driver current.

TYPICAL CHARACTERISTICS

V_{REF} vs. Temperature

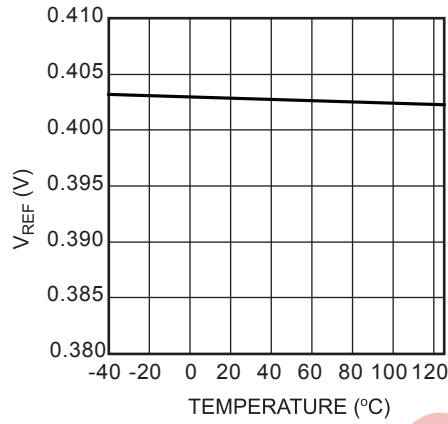

NOT RECOMMENDED FOR
NEW DESIGNS
REFER TO MP4033

TYPICAL PERFORMANCE CHARACTERISTICS

$V_{IN} = 120VAC/60Hz$, 7 LEDs in series, $I_O = 350mA$, $V_O = 21V$, $L_P = 1.6mH$, $N_P:N_S:N_{AUX} = 82:16:19$, TRIAC dimmable.

Efficiency vs. V_{IN}

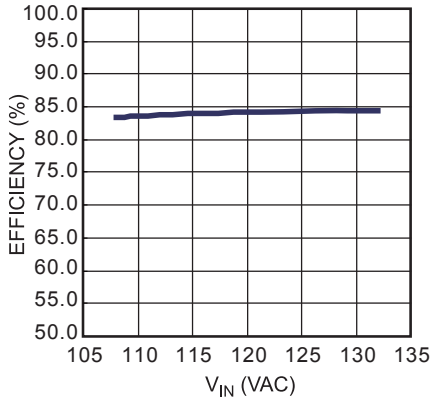

Line Regulation vs. V_{IN}

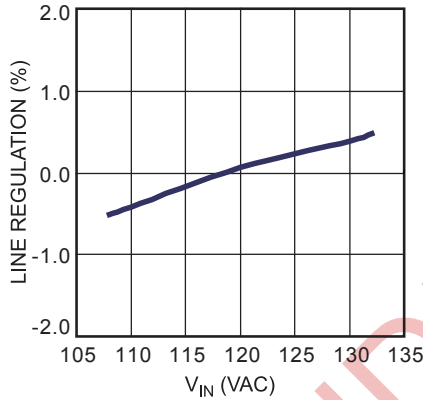

PF & THD vs. V_{IN}

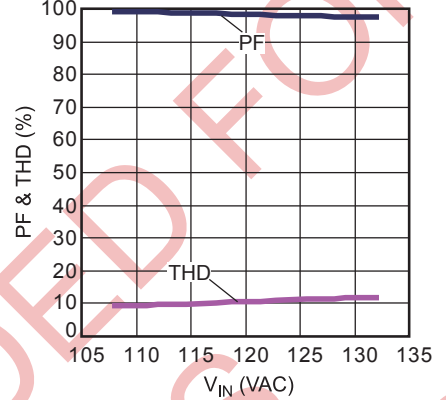

Dimming Curve

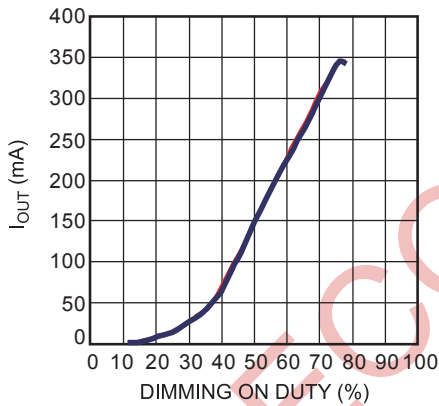

Conducted EMI Based on Line L

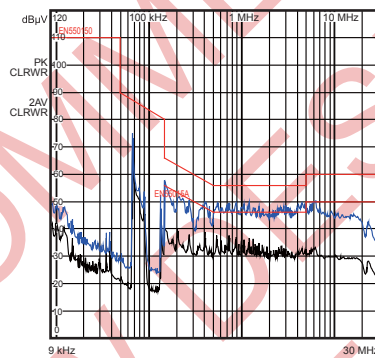

Conducted EMI Based on Line N

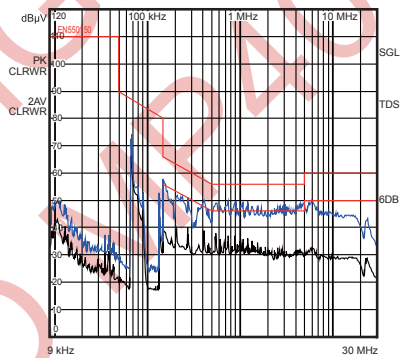

Steady State

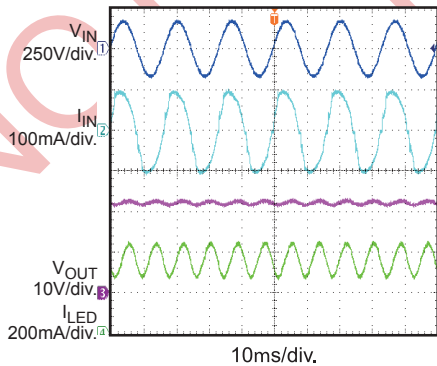

Steady State

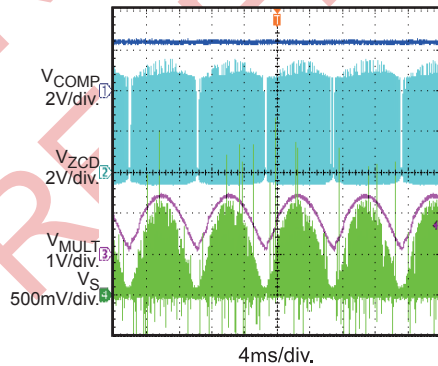

V_{IN} Start-Up

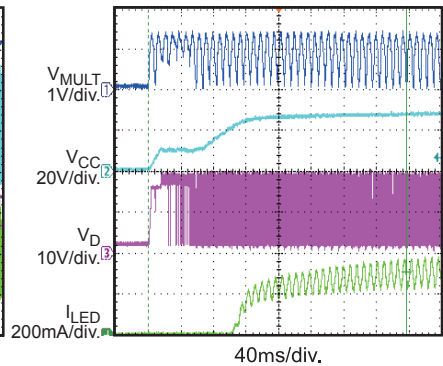

TYPICAL PERFORMANCE CHARACTERISTICS

V_{IN} =120VAC/60Hz, 7 LEDs in series, I_O =350mA, V_O =21V, L_P =1.6mH, $N_P:N_S:N_{AUX}$ =82:16:19, TRIAC dimmable.

Dimming Performance
77% Dimming on Duty with S600

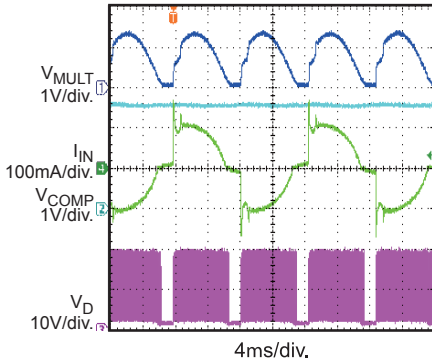

Dimming Performance
50% Dimming on Duty with S600

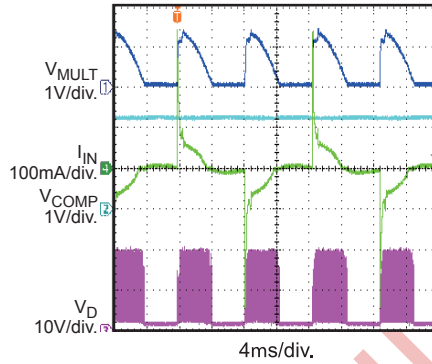

Dimming Performance
12% Dimming on Duty with S600

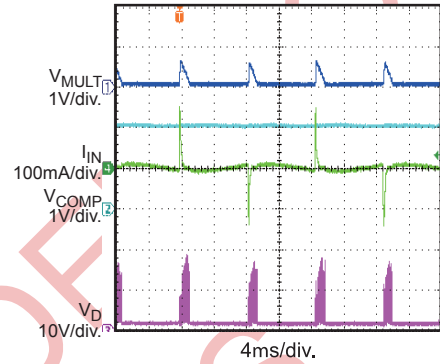

Dimming Performance
68% Dimming on Duty with DVELV-300P-WH

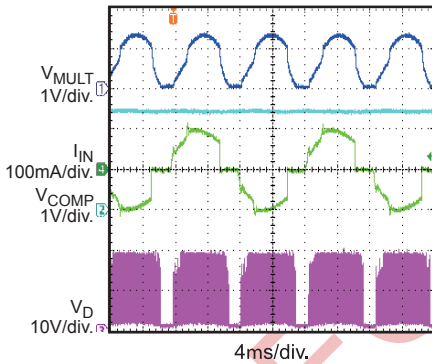

Dimming Performance
50% Dimming on Duty with DVELV-300P-WH

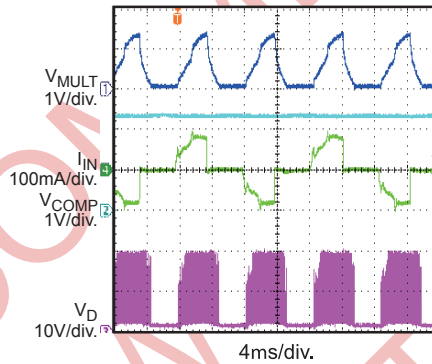

Dimming Performance
17% Dimming on Duty with DVELV-300P-WH

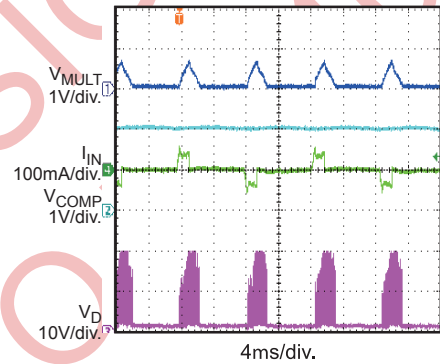

Over Voltage Protection
LEDs Load Open at Normal Operation then Recovery

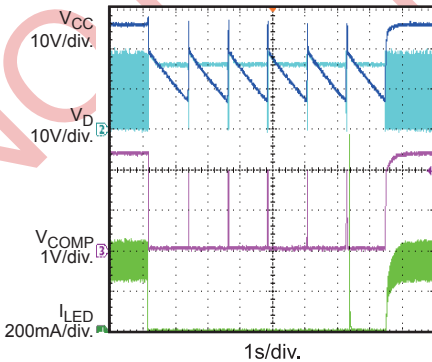

Over Voltage Protection
LEDs Load Open at Normal Operation then Recovery

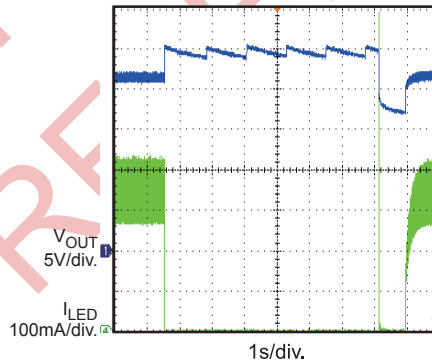

Short Circuit Protection
LEDs Load Open at Normal Operation then Recovery

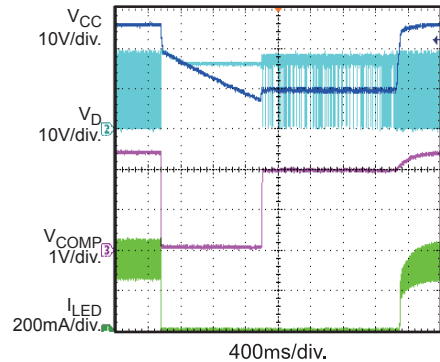

BLOCK DIAGRAM

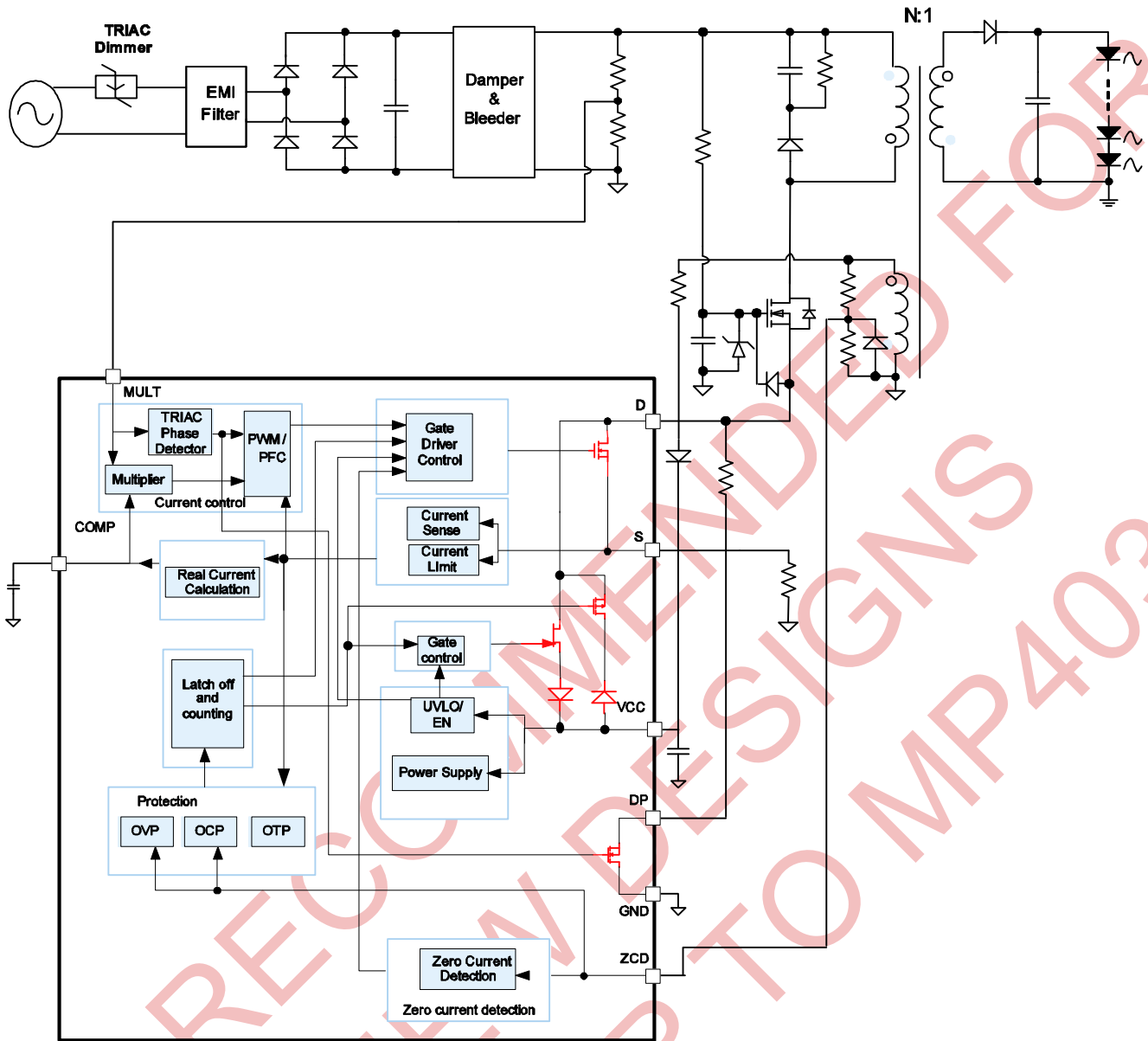

Figure 1: Functional Block Diagram

OPERATION

The MP4030A is a TRIAC-dimmable, primary-side-controlled, offline, LED controller designed for high-performance LED lighting. The MP4030A can accurately control the LED current using real-current-control based on primary-side information. It can also achieve a high power factor to eliminate noise on the AC line. The integrated V_{CC} charging circuit can achieve fast start-up without any perceptible delay. The MP4030A is suitable for TRIAC-based dimming with an extended dimming range.

Boundary-Conduction Mode

During the external MOSFET ON time (t_{ON}), the rectified input voltage applied across the primary-side inductor (L_P) increases the primary current increases linearly from zero to the peak value (I_{PK}). When the external MOSFET turns off, the energy stored in the inductor forces the secondary side diode to turn on, and the inductor current decreases linearly from the peak value to zero. When the current decreases to zero, the parasitic resonance caused by the inductor and the combined parasitic capacitances decreases the MOSFET drain-source voltage, which is also reflected on the auxiliary winding (see Figure 2). The zero-current detector (ZCD) generates the external MOSFET turn-on signal when the ZCD voltage falls below 0.35V after a blanking time and ensures the MOSFET turns on at a relatively low voltage (see Figure 3).

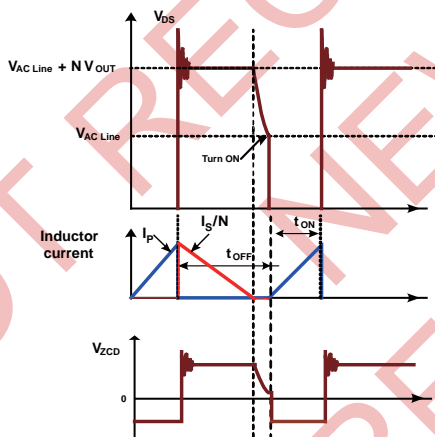

Figure 2: Boundary-Conduction Mode

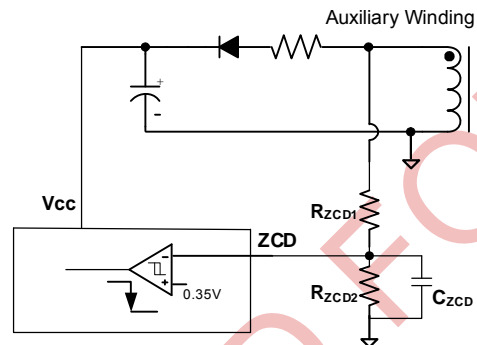

Figure 3: Zero-Current Detector

As a result, there are virtually no primary-switch turn-on losses and no secondary-diode reverse-recovery losses. This ensures high efficiency and low EMI noise.

Real-Current Control

The proprietary real-current-control method allows the MP4030A to control the secondary-side LED current based on primary-side information. The output LED mean current can be approximated as:

$$I_O = \frac{N \cdot V_{REF}}{2 \cdot R_S}$$

Where:

- N is the turn ratio of the primary side to the secondary side,
- V_{REF} is the reference voltage (typically value is 0.403V),
- R_S is the sense resistor between the MOSFET source and GND.

Power-Factor Correction

The MULT pin connects to the tap of a resistor divider from the rectified, instantaneous, line voltage. The multiplier output is also sinusoidal. This signal provides the reference for the current comparator against the primary-side-inductor current, which shapes the primary-peak current into a sinusoid with the same phase as the input line voltage. This achieves a high power factor.

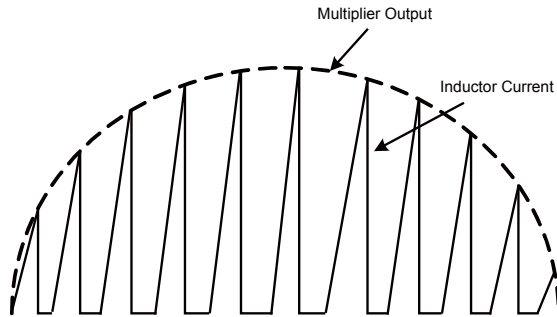
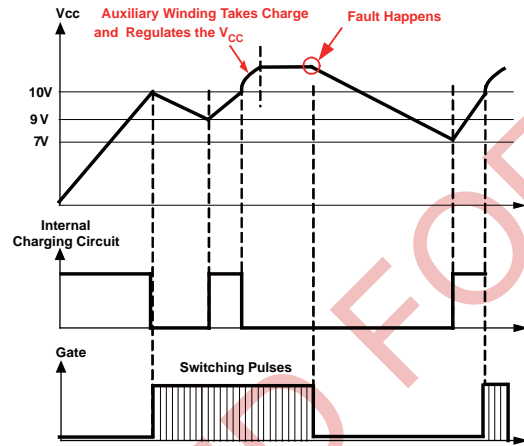

Figure 4: Power-Factor Correction

The multiplier's maximum output voltage to the current comparator is clamped at 2.3V to limit the cycle-by-cycle current. The multiplier's minimum output voltage is clamped to 0.1V to ensure a turn-on signal during the TRIAC dimming OFF interval to pull down the rectifier input voltage for accurate dimming-phase detection.

V_{CC} Timing Sequence

Initially, V_{CC} charges through the internal charging circuit from the AC line. When V_{CC} reaches 10V, the internal charging circuit stops charging, the control logic initializes and the internal main MOSFET begins to switch. Then the auxiliary winding takes over the power supply. However, the initial auxiliary-winding positive voltage may not be large enough to charge V_{CC}, causing V_{CC} to drop. Instead, if V_{CC} drops below the 9V threshold, the internal charging circuit triggers and charges V_{CC} to 10V again. This cycle repeats until the auxiliary winding voltage is high enough to power V_{CC}.

If any fault occurs during this time, the switching and the internal charging circuit will stop and latch, and V_{CC} drops. When V_{CC} decreases to 7V, the internal charging circuit re-charges for auto-restart.

Figure 5: V_{CC} Timing Sequence

Auto-Start

The MP4030A includes an auto-starter that starts timing when the MOSFET turns off. If ZCD fails to send a turn-on signal after 115μs, the auto-starter sends a turn-on signal to avoid unnecessary IC shutdowns if ZCD fails.

Minimum OFF Time

The MP4030A operates with a variable switching frequency and the frequency changes with the instantaneous input-line voltage. To limit the maximum frequency and for good EMI performance, the MP4030A employs an internal minimum OFF-time limiter of 5.1μs, as shown in

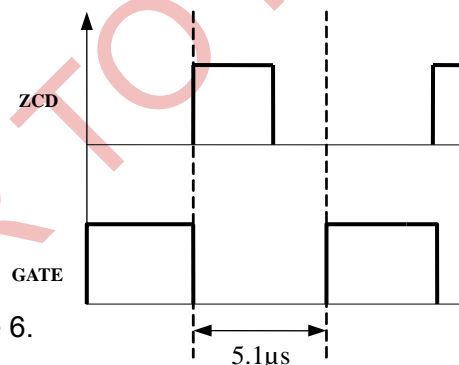

Figure 6.

Figure 6: Minimum OFF time

MPS CONFIDENTIAL
NO INTERNAL USE ONLY
DO NOT DISTRIBUTE
REFER TO MP4033

Leading-Edge Blanking

An internal LEB unit between the S pin and the current-comparator input blocks the path from the S pin to the current comparator input during the blanking time to avoid premature switching-pulse termination due to the parasitic capacitances discharging when the MOSFET turns on, as shown in Figure 7.

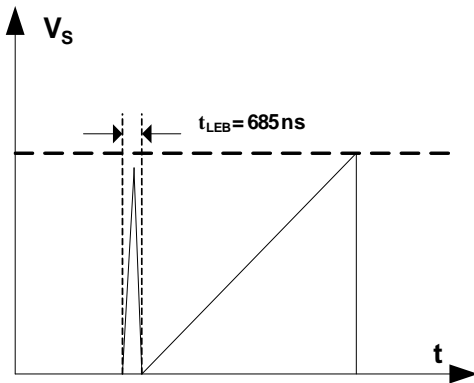

Figure 7: Leading-Edge Blanking

Output Over-Voltage Protection (OVP)

Output OVP prevents component damage from over-voltage conditions. The auxiliary winding voltage's positive plateau is proportional to the output voltage, and the IC monitors this auxiliary winding voltage from the ZCD pin instead of directly monitoring the output voltage as shown in Figure 8. Once the ZCD pin voltage exceeds 5.4V, the OVP signal triggers and latches, the gate driver turns off, and the IC enters quiescent mode. When V_{CC} drops below the UVLO threshold, the IC shuts down and the system restarts. The output OVP set point can be calculated as:

$$V_{OUT_OVP} \cdot \frac{N_{AUX}}{N_{SEC}} \cdot \frac{R_{ZCD2}}{R_{ZCD1} + R_{ZCD2}} = 5.4V$$

Where:

V_{OUT_OVP} is the output OVP threshold,

N_{AUX} is the number of auxiliary winding turns, and

N_{SEC} is the number of secondary winding turns.

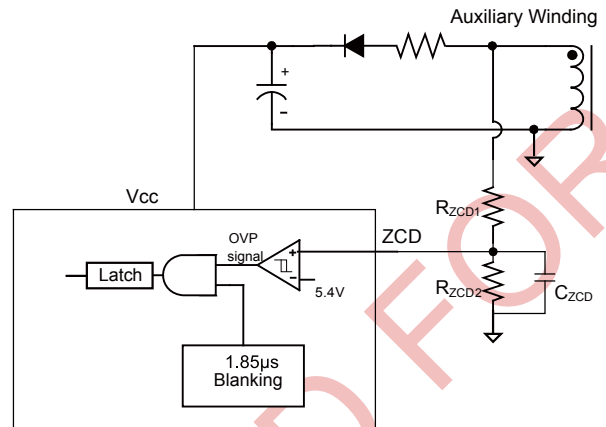

Figure 8: OVP Sampling Circuit

To avoid switch-on spikes mis-triggering OVP, OVP sampling has a blanking period (t_{OVP_LEB}) of around $1.85\mu s$, as shown in Figure 9.

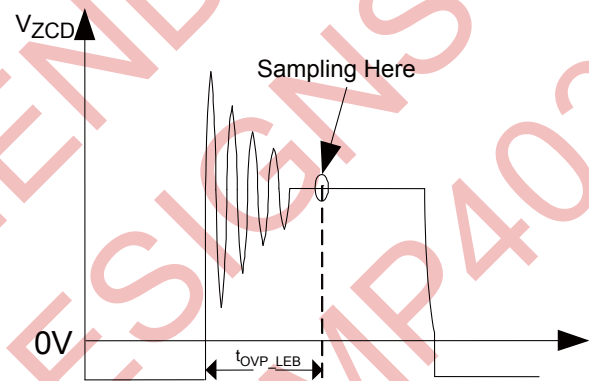

Figure 9: ZCD Voltage and OVP Sampling

Output Short-Circuit Protection (SCP)

If a short circuit on the secondary-side occurs, ZCD pin can't detect the zero-crossing signal and system works in $115\mu s$ auto-restart mode until V_{CC} drops below UVLO before restarting.

Primary Over-Current Protection (OCP)

The S pin has an internally-integrated comparator for primary OCP. When the gate is on, the comparator is enabled. Over-current occurs when V_S exceeds 2.73V after a blanking time. Then the IC shuts down and will not restart until V_{CC} drops below UVLO. Figure 10 shows OCP.

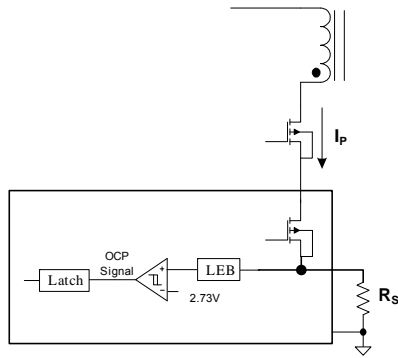

Figure 10: Over-Current Protection Circuit

Thermal Shutdown

To prevent internal temperatures from exceeding 150°C and causing lethal thermal damage, the MP4030A shuts down the switching cycle and latches until V_{CC} drops below UVLO before restarting.

TRIAC-Based Dimming Control

The MP4030A implements TRIAC-based dimming. The TRIAC dimmer consists of a bi-directional SCR with an adjustable turn-on phase. Figure 11 shows the leading-edge TRIAC dimmer waveforms.

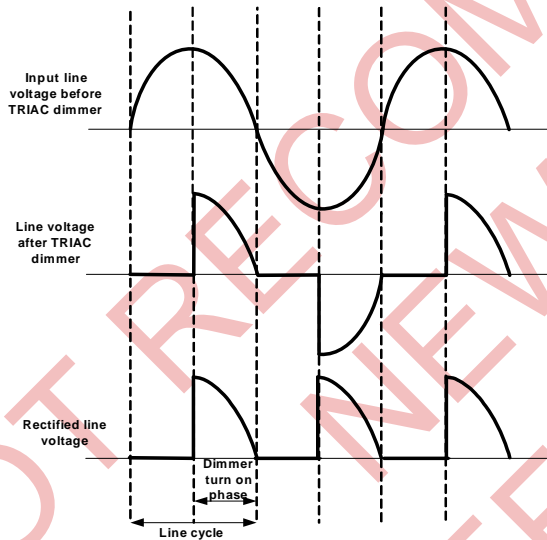

Figure 11: TRIAC Dimmer Waveforms

The MP4030A detects the dimming turn-on cycle through the MULT pin, which is fed into the control loop to adjust the internal reference voltage. When V_{MULT} exceeds 0.35V, the device treats this signal as the turn-on of the dimmer. When V_{MULT} falls below 0.15V, the system treats

this as a dimmer turn-off signal. The MP4030A has a 25% line-cycle-detection blanking time for each line cycle, the real-phase-detector output inserts this blanking time, as shown in Figure 12, such that if the turn-on cycle exceeds 75% of the line cycle, the output remains at the maximum current. This implementation improves line regulation during the maximum TRIAC turn-on cycle with or without a dimmer.

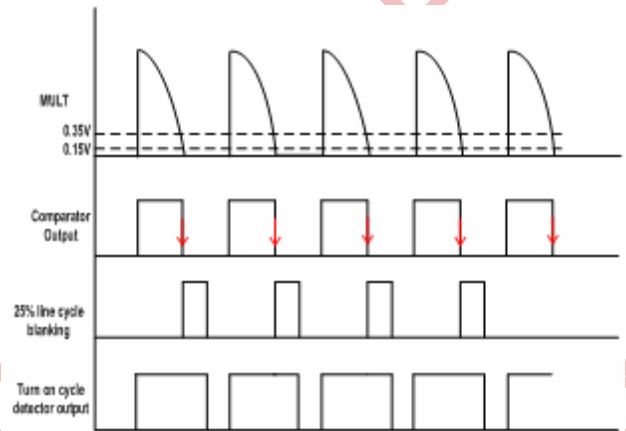

Figure 12: Dimming Turn-On Cycle Detector

If the turn-on cycle decreases to less than 75% of the line cycle, the internal reference voltage decreases with the dimming turn-on phase, and the output current decreases accordingly. As the dimming turn-on cycle decreases, the COMP voltage also decreases. Once the COMP voltage reaches 1.9V, it is clamped so that the output current decreases slowly to maintain the TRIAC holding current and avoid random flicker. Figure 13 shows the relationship between the dimming turn-on phase and output current.

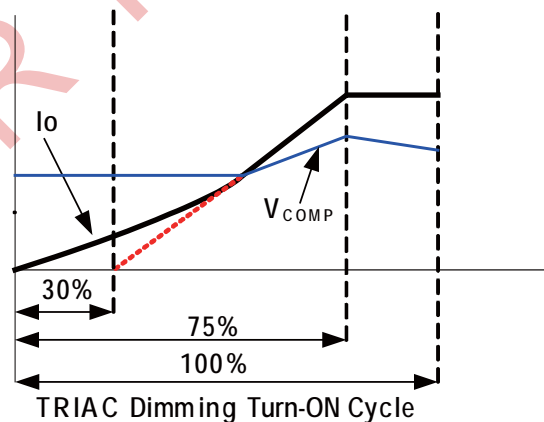

Figure 13: Dimming Curve

Dimming Pull-Down MOSFET

The DP MOSFET turns on when V_{MULT} decreases to 0.25V. Connect a resistor to the D pin to provide the pull-up current during the dimming turn-off interval, and to quickly pull down the rectified line voltage to zero to avoid any mis-detection on the MULT pin.

NOT RECOMMENDED FOR
NEW DESIGNS
REFER TO MP4033

RIPPLE SUPPRESSOR

(Innovative Proprietary)

For dimming LED lighting application, a single stage PFC converter needs large output capacitor to reduce the ripple whose frequency is double of the Grid. And in deep dimming situation, the LED would shimmer caused by the dimming on duty which is not all the same in every line cycle. What's more, the Grid has noise or inrush which would bring out shimmer even flicker. Figure 14 shows a ripple suppressor, which can shrink the LED current ripple obviously.

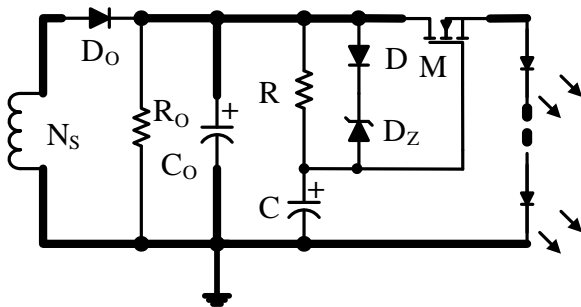

Figure14: Ripple Suppressor

Principle:

Shown in Figure 14, Resistor R, capacitor C, and MOSFET M compose the ripple suppressor. Through the RC filter, C gets the mean value of the output voltage V_{Co} to drive the MOSFET M. M works in variable resistance area. C's voltage V_C is steady makes the LEDs voltage is steady, so the LEDs current will be smooth. MOSFET M holds the ripple voltage v_{Co} of the output.

Diode D and Zener diode D_Z are used to restrain the overshoot at start-up. In the start-up process, through D and D_Z , C is charged up quickly to turn on M, so the LED current can be built quickly. When V_C rising up to about the steady value, D and D_Z turn off, and C combines R as the filter to get the mean voltage drop of V_{Co} .

The most important parameter of MOSFET M is the threshold voltage V_{th} which decides the power loss of the ripple suppressor. Lower V_{th} is better if the MOSFET can work in variable resistance area. The BV of the MOSFET can be selected as double as V_{Co} and the Continuous Drain current level can be selected as decuple as the LEDs' current at least.

About the RC filter, it can be selected by $\tau_{RC} \geq 50/f_{LineCycle}$. Diode D can select 1N4148, and the Zener voltage of D_Z is as small as possible when guarantee $V_D + V_{Dz} > 0.5 \cdot V_{Co_PP}$.

Optional Protection Circuit

In large output voltage or large LEDs current application, MOSFET M may be destroyed by over-voltage or over-current when LED+ shorted to LED- at working.

Gate-Source (GS) Over-voltage Protection:

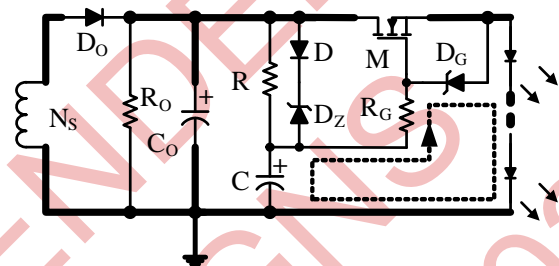

Figure 15: Gate-Source OVP Circuit

Figure 15 shows GS over-voltage protection circuit. Zener diode D_G and resistor R_G are used to protect MOSFET M from GS over-voltage damaged. When LED+ shorted to LED- at normal operation, the voltage drop on capacitor C is high, and the voltage drop on Gate-Source is the same as capacitor C. The Zener diode D_G limits the voltage V_{GS} and R_G limits the charging current to protect D_G . R_G also can limit the current of D_Z at the moment when LED+ shorted to LED-. V_{DG} should bigger than V_{th} .

Drain-Source Over-voltage and Over-current Protection

As Figure 16 shows, NPN transistor T, resistor R_C and R_E are set up to protect MOSFET M from over-current damaged when output short occurs at normal operation. When LED+ shorted to LED-, the voltage v_{DS} of MOSFET is equal to the v_{Co} which has a high surge caused by the parasitic parameter. Zener Diode D_{DS} protects MOSFET from over-voltage damaged. Transistor T is used to pull down the V_{GS} of M. When M turns off, the load is opened, MP4030A detects there is an OVP happened, so the IC functions in quiescent.

The pull down point is set by R_C and R_E :

$$\frac{R_E}{R_C + R_E} \cdot \frac{V_{C_{o_1}}}{2} = 0.7V$$

MOSFET LIST

In the Table 1, there are some recommended MOSFET for ripple suppressor.

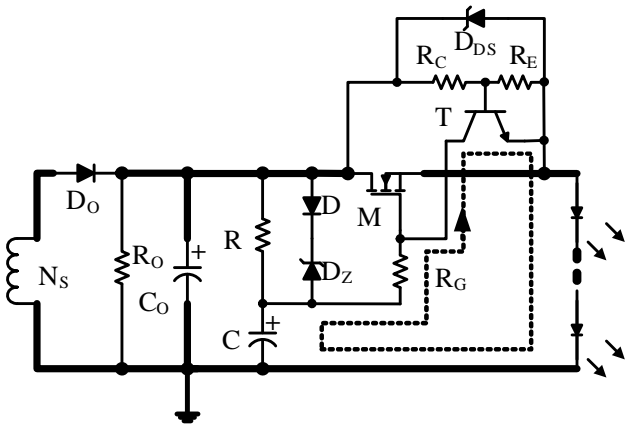

Figure 16: Drain-Source OVP and OCP Circuit

Table 1: MOSFET LIST

Manufacture P/N	Manufacture	V_{DS}/I_D	$V_{th}(V_{DS}=V_{GS}@T_J=25^\circ C)$	Power Stage
Si4446DY	Vishay	40V/3A	0.6-1.6V@ $I_D=250\mu A$	<10W
FTD100N10A	IPS	100V/17A	1.0-2.0V@ $I_D=250\mu A$	5-15W
P6015CDG	NIKO-SEM	150V/20A	0.45-1.20V@ $I_D=250\mu A$	10-20W

TYPICAL APPLICATION CIRCUIT

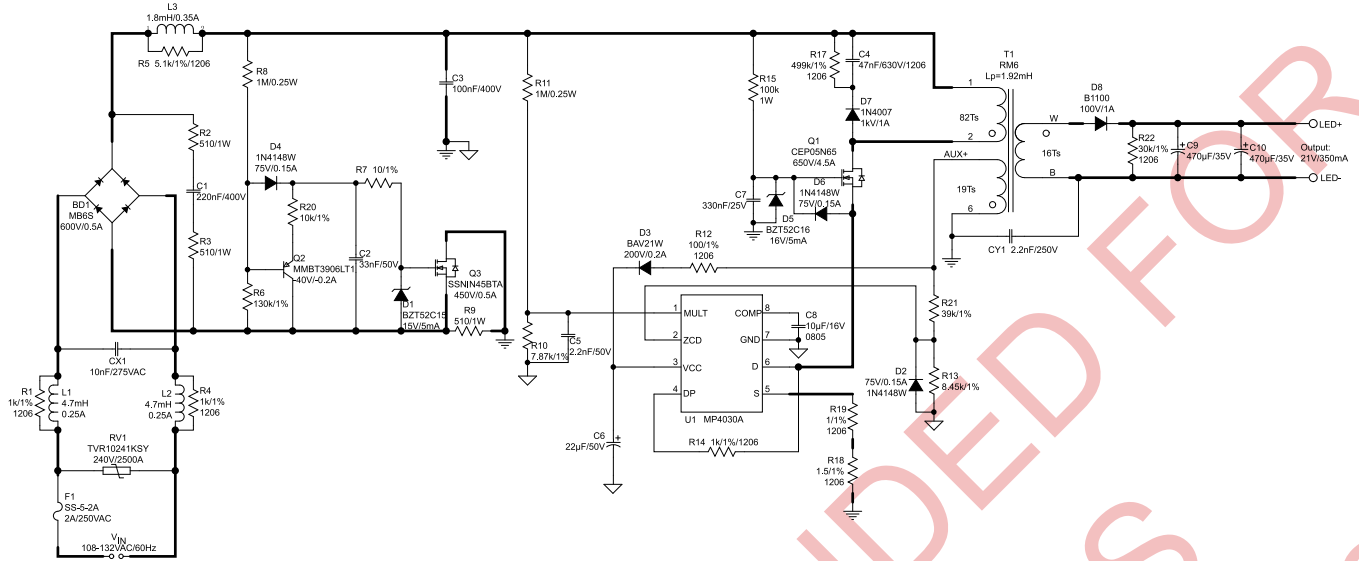

Figure 17: 108-132VAC Input, TRIAC dimmable, Isolated Flyback Converter, Drive 7 LEDs in Series, 350mA LED Current for LED Lighting, EVB Model: EV4030A-S-00A

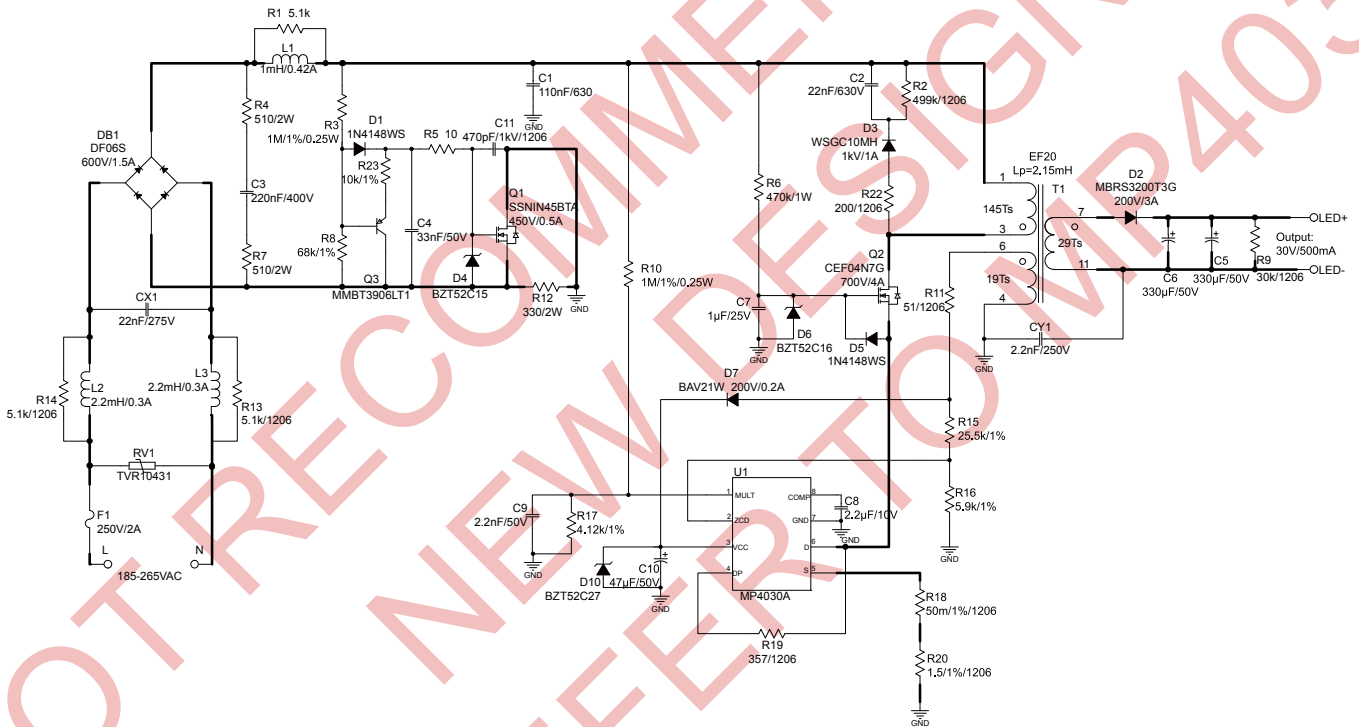
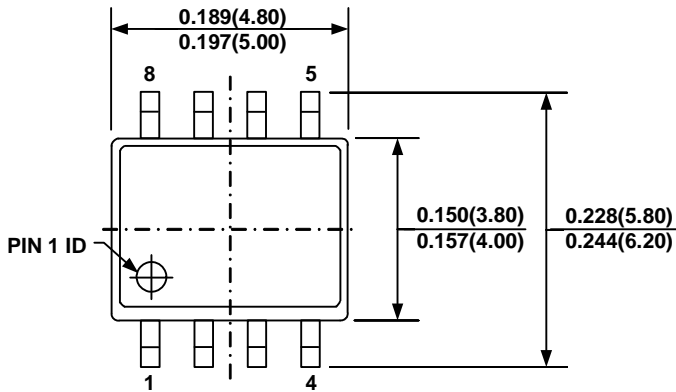
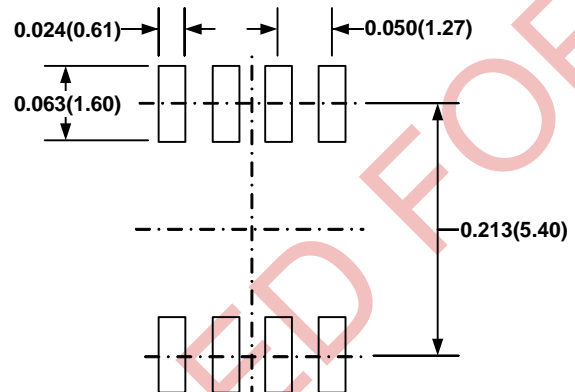
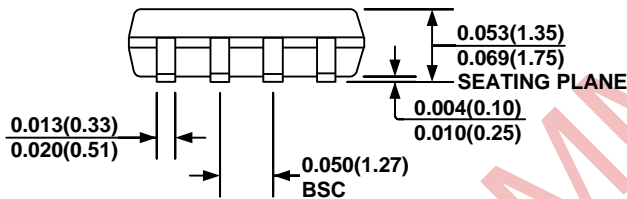
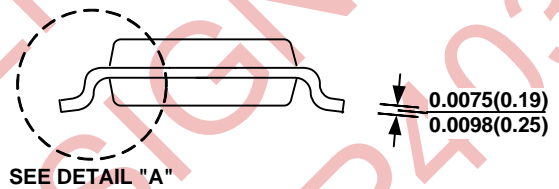
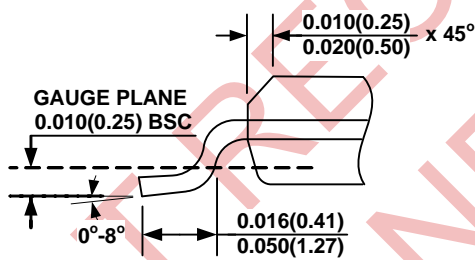

Figure 18: 198-265VAC Input, TRIAC dimmable, Isolated Flyback Converter, Drive 10 LEDs in Series, 530mA LED Current for LED Lighting, EVB Model: EV4030A-S-00B

PACKAGE INFORMATION
SOIC8

TOP VIEW

RECOMMENDED LAND PATTERN

FRONT VIEW

SIDE VIEW

DETAIL "A"
NOTE:

- 1) CONTROL DIMENSION IS IN INCHES. DIMENSION IN BRACKET IS IN MILLIMETERS.
- 2) PACKAGE LENGTH DOES NOT INCLUDE MOLD FLASH, PROTRUSIONS OR GATE BURRS.
- 3) PACKAGE WIDTH DOES NOT INCLUDE INTERLEAD FLASH OR PROTRUSIONS.
- 4) LEAD COPLANARITY (BOTTOM OF LEADS AFTER FORMING) SHALL BE 0.004" INCHES MAX.
- 5) DRAWING CONFORMS TO JEDEC MS-012, VARIATION AA.
- 6) DRAWING IS NOT TO SCALE.

NOTICE: The information in this document is subject to change without notice. Users should warrant and guarantee that third party Intellectual Property rights are not infringed upon when integrating MPS products into any application. MPS will not assume any legal responsibility for any said applications.

X-ON Electronics

Largest Supplier of Electrical and Electronic Components

Click to view similar products for [LED Lighting Drivers](#) category:

Click to view products by [Monolithic Power Systems](#) manufacturer:

Other Similar products are found below :

[LV5235V-MPB-H](#) [MB39C602PNF-G-JNEFE1](#) [MIC2871YMK-T5](#) [AL1676-10BS7-13](#) [AL1676-20AS7-13](#) [AP5726WUG-7](#) [ICL8201](#)
[IS31BL3228B-UTLS2-TR](#) [IS31BL3506B-TTLS2-TR](#) [AL3157F-7](#) [AP5725FDCG-7](#) [LV52204MTTBG](#) [AP5725WUG-7](#) [STP4CMPQTR](#)
[NCL30086BDR2G](#) [CAT4004BHU2-GT3](#) [LV52207AXA-VH](#) [AP1694AS-13](#) [TLE4242EJ](#) [AS3688](#) [IS31LT3172-GRLS4-TR](#) [TLD2311EL](#)
[KTD2694EDQ-TR](#) [KTZ8864EJAA-TR](#) [IS32LT3174-GRLA3-TR](#) [MP2488DN-LF-Z](#) [NLM0010XTSA1](#) [AL1676-20BS7-13](#)
[ZXLD1370QESTTC](#) [MPQ7220GF-AEC1-P](#) [MPQ7220GR-AEC1-P](#) [MPQ4425BGJ-AEC1-P](#) [MPQ7220GF-AEC1-Z](#) [MPQ7220GR-AEC1-Z](#)
[MPQ4425BGJ-AEC1-Z](#) [IS31FL3737B-QFLS4-TR](#) [IS31FL3239-QFLS4-TR](#) [KTD2058EUAC-TR](#) [KTD2037EWE-TR](#) [DIO5662ST6](#)
[IS31BL3508A-TTLS2-TR](#) [KTD2026BEWE-TR](#) [MAX20052CATC/V+](#) [MAX25606AUP/V+](#) [BD6586MUV-E2](#) [BD9206EFV-E2](#) [BD9416FS-](#)
[E2](#) [LYT4227E](#) [LYT6079C-TL](#) [MP3394SGF-P](#)