

## DESCRIPTION

The MP6205 Power Distribution Switch features internal current limiting to prevent damage to host devices due to faulty load conditions. The MP6205 Analog switch features 90mΩ on-resistance and operates from 2.7V to 5.5V input. It is available with a guaranteed current limit, making it ideal for load switching applications. The MP6205 has built-in protection for both over current and increased thermal stress. For over current, the device will limit the current by changing to a constant current mode.

As the temperature increases as a result of short circuit, the device will shut off. The device will recover once the device temperature reduces to approx 120°C.

The MP6205 is available in MSOP8E package.

## FEATURES

- 500mA Continuous Current
- Accurate Current Limit
- 2.7V to 5.5V Supply Range
- 140uA Quiescent Current
- 90mΩ MOSFET
- Thermal-Shutdown Protection
- Under-Voltage Lockout
- 8ms FLAG Deglitch Time
- No FLAG Glitch During Power Up
- Reverse Current Blocking
- MSOP8E Package
- UL Recognized: E322138

## APPLICATIONS

- Smartphone and PDA
- Portable GPS Device
- Set-top-box
- USB Power Distribution

"MPS" and "The Future of Analog IC Technology" are Trademarks of Monolithic Power Systems, Inc.

## TYPICAL APPLICATION

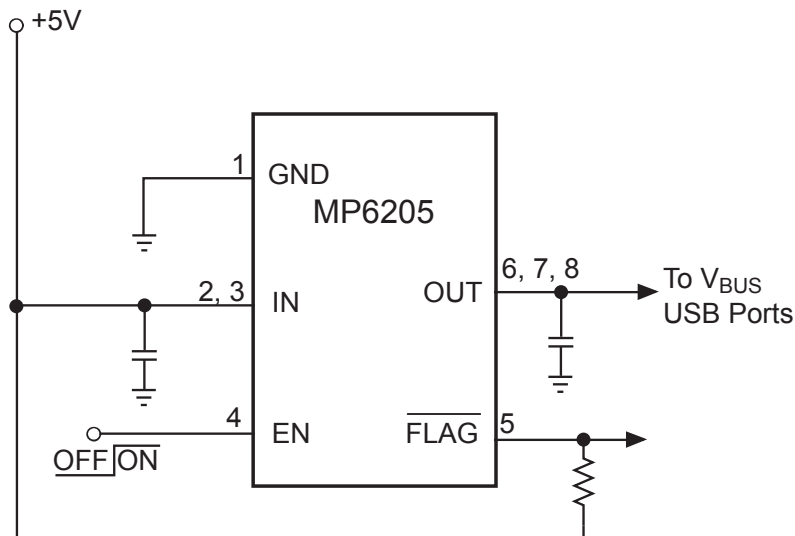

SINGLE-CHANNEL



UL Recognized Component

### ORDERING INFORMATION

Part Number*	Enable	Switch	Maximum Continuous Load Current	Maximum Short-Circuit Current @ T <sub>A</sub> =25°C	Package	Top Marking	Temperature
MP6205DH	Active High	Single	500mA	1100mA	MSOP8E	6205D	-40°C to +85°C

\* For Tape & Reel, add suffix -Z (eg. MP6205DH-Z).

For RoHS Compliant Packaging, add suffix -LF. (eg. MP6205DH-LF-Z)

### PACKAGE REFERENCE

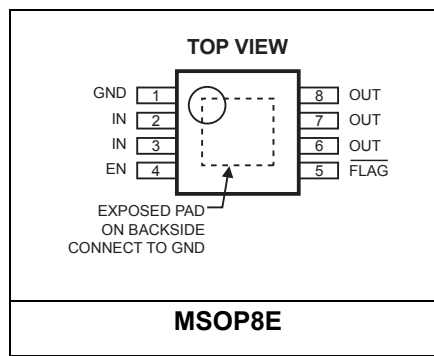

### ABSOLUTE MAXIMUM RATINGS <sup>(1)</sup>

IN .....	-0.3V to +6.0V
EN, FLAG, OUT to GND .....	-0.3V to +6.0V
Junction Temperature .....	150°C
Lead Temperature .....	260°C
Storage Temperature .....	-65°C to +150°C
Operating Temperature .....	-40°C to +85°C

### Thermal Resistance <sup>(2)</sup>

	$\theta_{JA}$	$\theta_{JC}$
MSOP8E .....	55	12... °C/W

**Notes:**

- 1) Exceeding these ratings may damage the device.
- 2) Measured on JESD51-7 4-layer PCB.

**ELECTRICAL CHARACTERISTICS <sup>(3)</sup>**
**V<sub>IN</sub>=5V, T<sub>A</sub>=+25°C, unless otherwise noted.**

Parameter	Condition	Min	Typ	Max	Units
IN Voltage Range		2.7		5.5	V
Supply Current	Single Channel		140	160	μA
Shutdown Current	Device Disable, V <sub>OUT</sub> =float, V <sub>IN</sub> =5.5V		1		μA
Off Switch Leakage	Device Disable, V <sub>IN</sub> =5.5V		1		μA
Current Limit		550		1100	mA
Trip Current	Current Ramp (slew rate ≤ 100A/s) on Output		1.2	1.6	A
Under-voltage Lockout	Rising Edge	1.95		2.65	V
Under-voltage Hysteresis			250		mV
FET On Resistance	I <sub>OUT</sub> =100mA and -40°C < T <sub>A</sub> < 85°C		90	130	mΩ
EN Input Logic High Voltage		2			V
EN Input Logic Low Voltage				0.8	V
FLAG Output Logic Low Voltage	I <sub>SINK</sub> =5mA			0.4	V
FLAG Output High Leakage Current	V <sub>IN</sub> =V <sub>FLAG</sub> =5.5V			1	μA
Thermal Shutdown			140		°C
Thermal Shutdown Hysteresis			20		°C
V <sub>OUT</sub> Rising Time, Tr <sup>(4)</sup>	V <sub>IN</sub> =5.5V, CL=1μF, RL=11Ω		0.9		ms
	V <sub>IN</sub> =2.7V, CL=1μF, RL=11Ω		1.7		ms
V <sub>OUT</sub> Falling Time, Tf <sup>(4)</sup>	V <sub>IN</sub> =5.5V, CL=1μF, RL=11Ω			0.5	ms
	V <sub>IN</sub> =2.7V, CL=1μF, RL=11Ω			0.5	ms
Turn On Time, Ton <sup>(5)</sup>	CL=100μF, RL=11Ω			3	ms
Turn Off Time, Toff <sup>(5)</sup>	CL=100μF, RL=11Ω			10	ms
FLAG Deglitch Time		4	8	15	ms
EN Input Leakage			1		μA
Reverse Leakage Current	OUT=5.5V, IN=GND		0.2		μA

**NOTE:**

- 3) Production test at +25°C. Specifications over the temperature range are guaranteed by design and characterization.  
 4) Measured from 10% to 90%.  
 5) Measured from (50%) EN signal to (90%) output signal.

**PIN FUNCTIONS**

Pin # MSOP	Name	Description
1	GND, Exposed Pad	Ground. Connect exposed pad to GND plane for optimal thermal performance
2, 3	IN	Input Voltage. Accepts 2.7V to 5.5V input.
4	EN	Enable Input. Active High.
5	$\overline{\text{FLAG}}$	IN-to-OUT Over-current, active-low output flag. Open-Drain.
6, 7, 8	OUT	Power-Distribution Switch Output.
-	N/C	

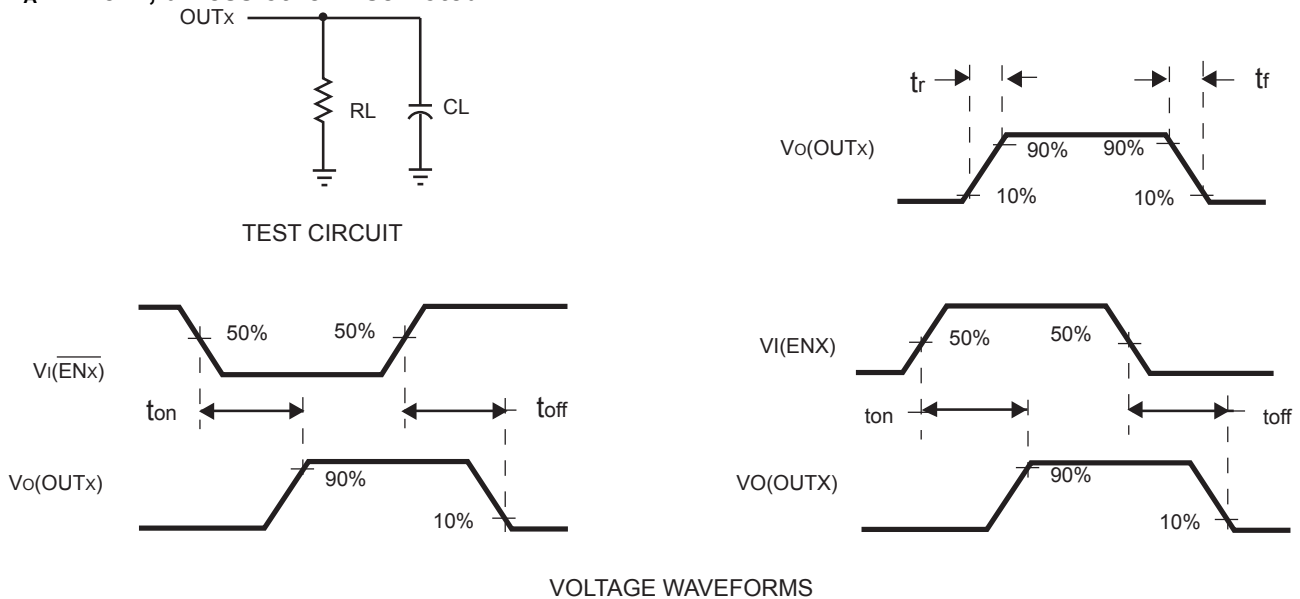
**TYPICAL PERFORMANCE CHARACTERISTICS**
 **$T_A = +25^\circ\text{C}$ , unless otherwise noted.**

**Figure 1—Test Circuit and Voltage Waveforms**

## TYPICAL PERFORMANCE CHARACTERISTICS

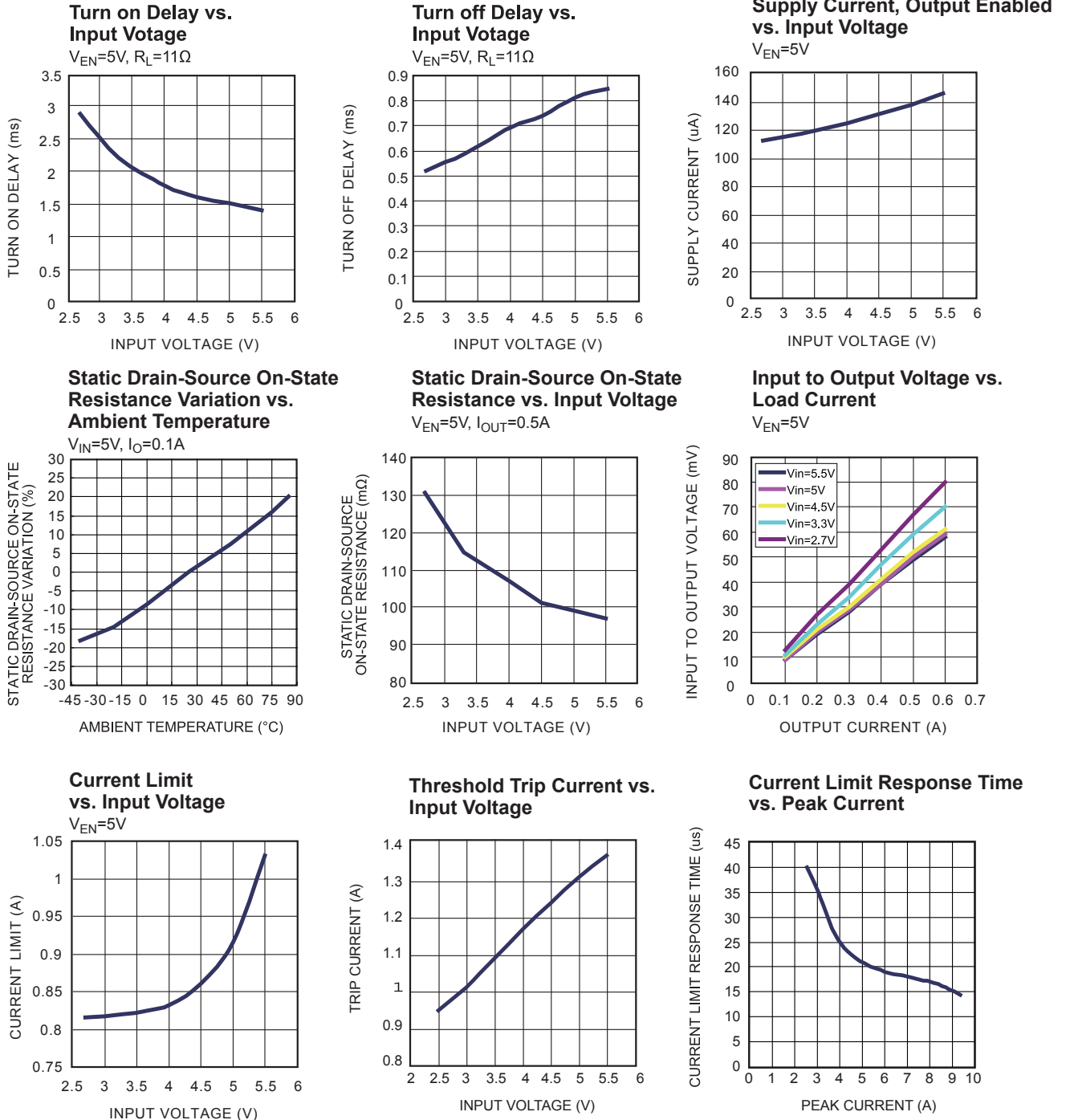
$V_{IN}=5.5V$ ,  $C_L = 2.2\mu F$ ,  $T_A = +25^\circ C$ , unless otherwise noted.

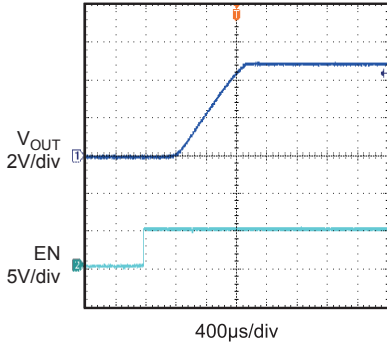
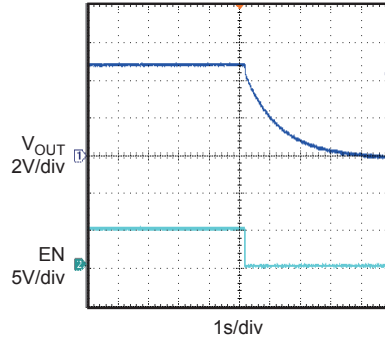
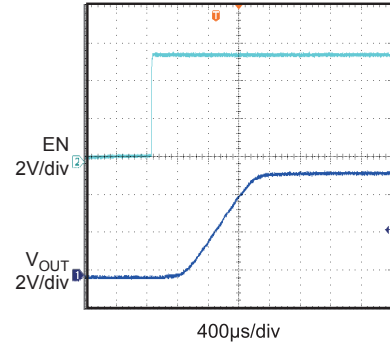
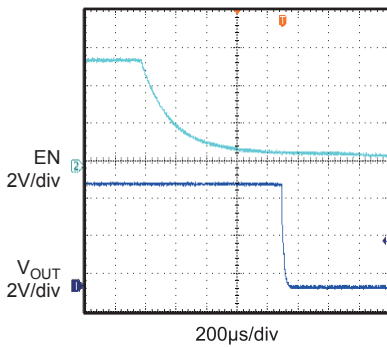
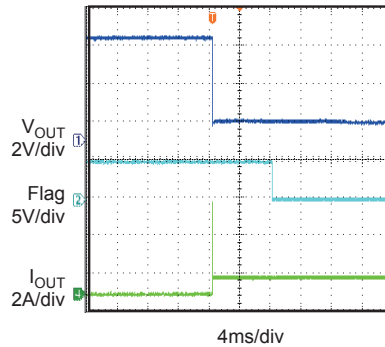
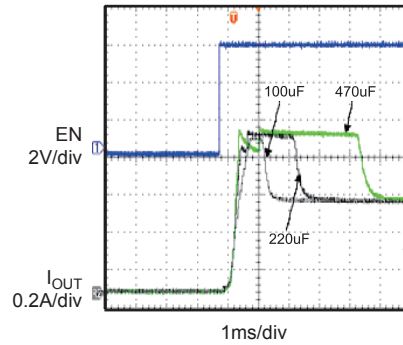
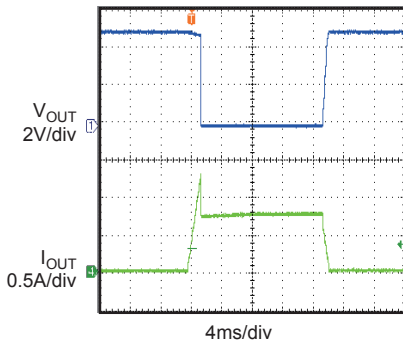
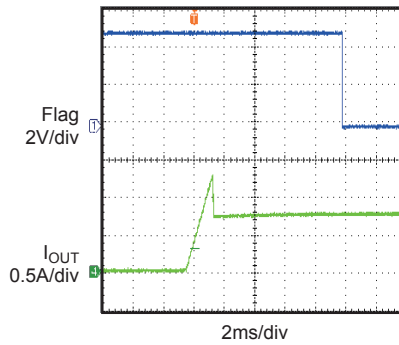
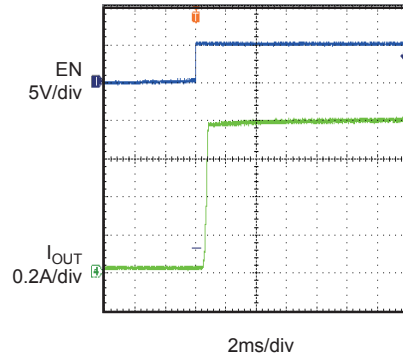

**TYPICAL PERFORMANCE CHARACTERISTICS (continued)**
 $V_{IN}=5.5V, C_L = 2.2\mu F, T_A = +25^\circ C$ , unless otherwise noted.

**Turn On Delay and Rise Time with 0.1uF Load**  
 $V_{EN}=5V, C_L=0.1\mu F$ 

**Turn Off Delay and Fall Time with 0.1uF Load**  
 $V_{EN}=5V, C_L=0.1\mu F$ 

**Turn On Delay and Rise Time**  
 $R_L=11\Omega, C_L=1\mu F$ 

**Turn Off Delay and Fall Time**  
 $R_L=11\Omega, C_L=1\mu F$ 

**1Ω Load Connected to Enabled Device**

**Inrush Current with Different Load Capacitance**  
 $R_L=11\Omega$ , Start up by EN

**Threshold Trip Current with Ramped Load on Enabled Device**

**Ramped Load on Enabled Device**

**Short Circuit Current, Device Enabled into Short**

FUNCTION BLOCK DIAGRAM

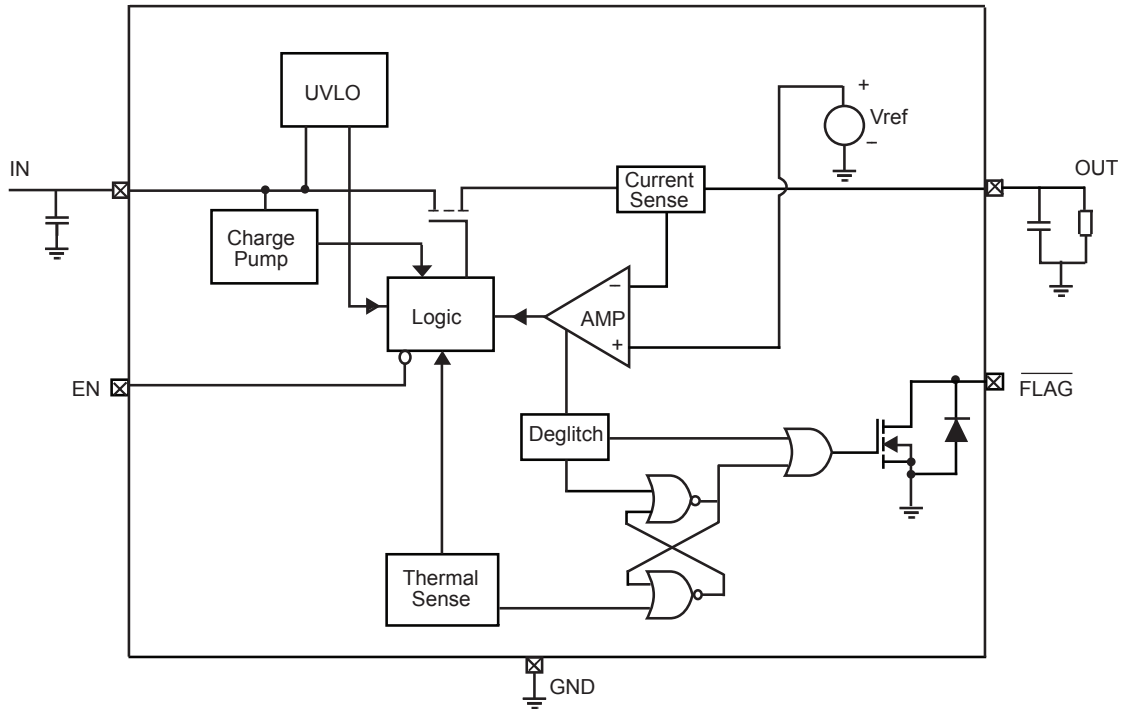

Figure 2—Functional Block Diagram

## DETAILED DESCRIPTION

### Over Current

When the load exceeds trip current (minimum threshold current triggering constant-current mode) or a short is present, MP6205 switches into a constant-current mode (current limit value). MP6205 will be shutdown only if the overcurrent condition stays long enough to trigger thermal protection.

Trigger overcurrent protection for different overload conditions occurring in applications:

- 1) The output has been shorted or overloaded before the device is enabled or input applied. MP6205 detects the short or overload and immediately switches into a constant-current mode.
- 2) A short or an overload occurs after the device is enabled. After the current-limit circuit has been tripped (reached the trip current threshold), the device switches into constant-current mode. However, high current may flow for a short period of time before the current-limit circuit can react.
- 3) Output current has been gradually increased beyond the recommended operating current. The load current rises until the trip current threshold is reached or until the thermal limit of the device is exceeded. The MP6205 is capable of delivering current up to the trip current threshold without damaging the device. Once the trip threshold has been reached, the device switches into its constant-current mode.

### Flag Response

The FLAG pin is an open drain configuration. This FAULT will report a fail mode after an 8ms deglitch timeout. This is used to ensure that no false fault signals are reported. This internal deglitch circuit eliminates the need for extend components. The FLAG pin is not deglitched during an over temp. or a voltage lockout.

### Thermal Protection

The purpose of thermal protection is to prevent damage in the IC by allowing excessive current to flow and heating the junction. The die temperature is internally monitored until the thermal limit is reached. Once this temperature is reached, the switch will turn off and allow the chip to cool. The switch has a built-in hysteresis.

### Under-voltage Lockout (UVLO)

This circuit is used to monitor the input voltage to ensure that the MP6205 is operating correctly. This UVLO circuit also ensures that there is no operation until the input voltage reaches the minimum spec.

### Enable

The logic pin disables the chip to reduce the supply current. The device will operate once the enable signal reaches the appropriate level. The input is compatible with both COMS and TTL.



### APPLICATION INFORMATION

#### Power-Supply Considerations

Over 10 $\mu$ F capacitor between IN and GND is recommended. This precaution reduces power-supply transients that may cause ringing on the input and improves the immunity of the device to short-circuit transients.

In order to achieve smaller output load transient, placing a high-value electrolytic capacitor on the output pin(s) is recommended when the output load is heavy.

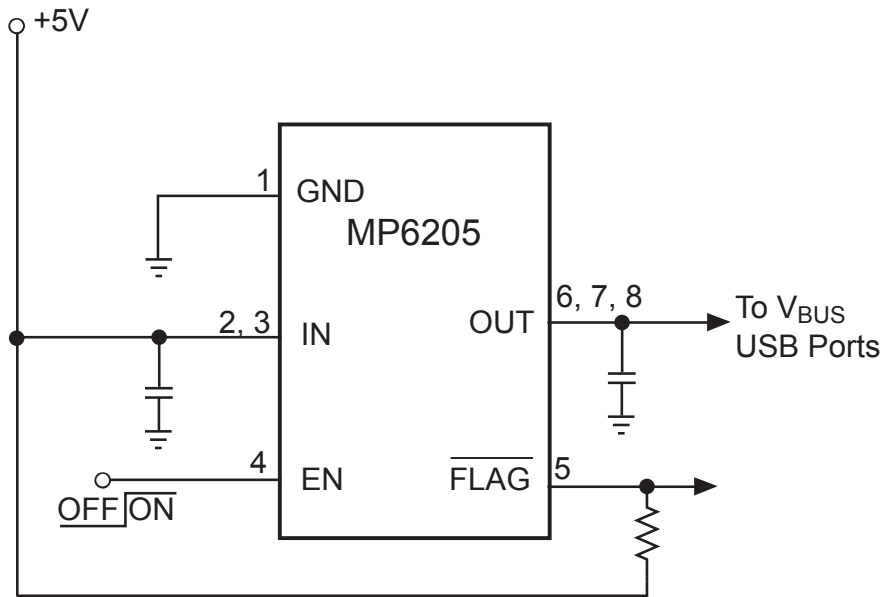

SINGLE-CHANNEL  
Figure 3—Application Circuit

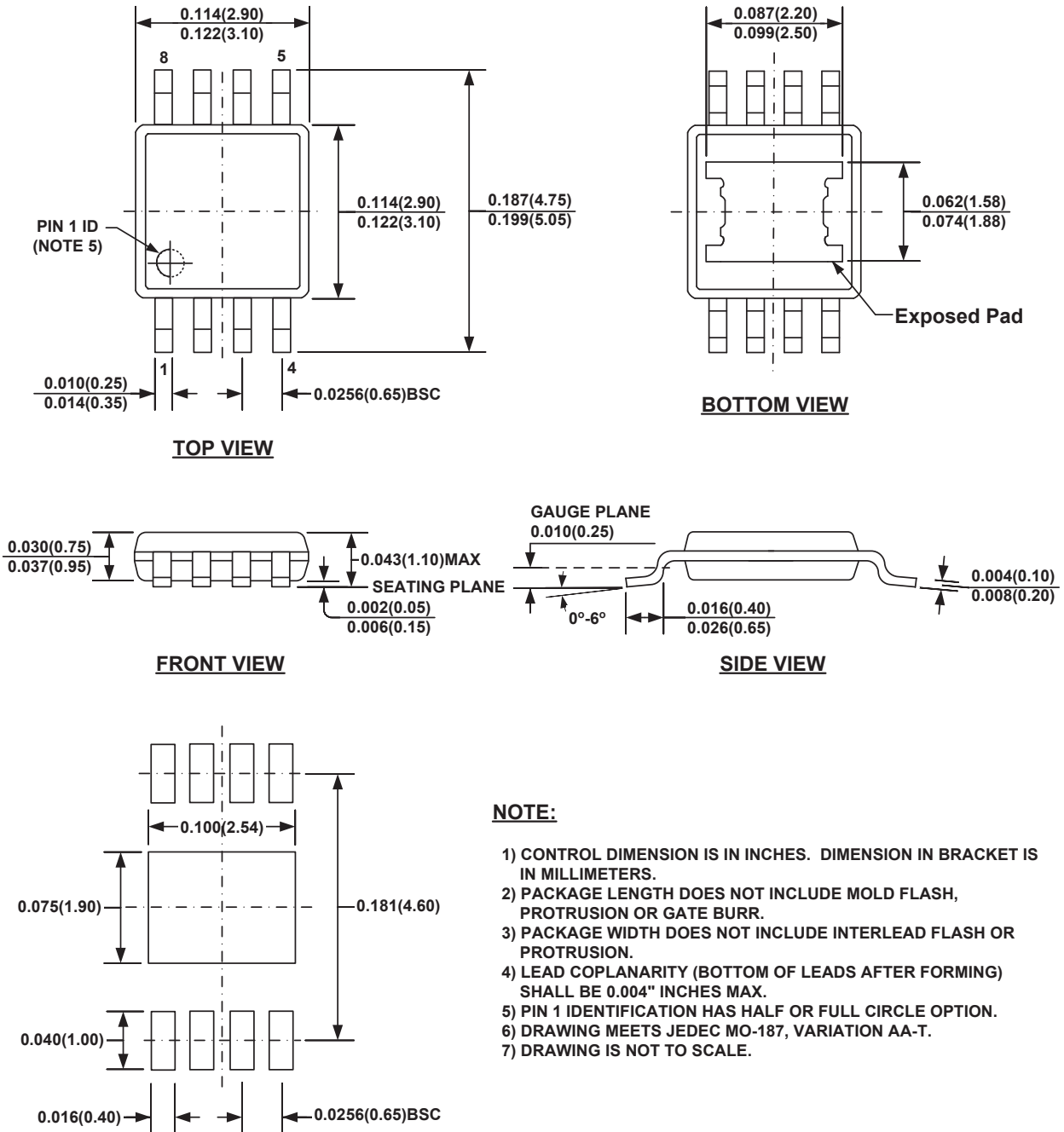
**PACKAGE INFORMATION**
**MSOP8E (EXPOSED PAD)**

**RECOMMENDED LAND PATTERN**

**NOTICE:** The information in this document is subject to change without notice. Users should warrant and guarantee that third party Intellectual Property rights are not infringed upon when integrating MPS products into any application. MPS will not assume any legal responsibility for any said applications.

## X-ON Electronics

Largest Supplier of Electrical and Electronic Components

*Click to view similar products for* [Power Switch ICs - Power Distribution](#) *category:*

*Click to view products by* [Monolithic Power Systems](#) *manufacturer:*

Other Similar products are found below :

[TCK111G,LF\(S\)](#) [FPF1018](#) [DS1222](#) [TCK2065G,LF](#) [SZNCP3712ASNT3G](#) [MIC2033-05BYMT-T5](#) [MIC2033-12AYMT-T5](#) [MIC2033-05BYM6-T5](#) [SLG5NT1437VTR](#) [SZNCP3712ASNT1G](#) [DML1008LDS-7](#) [KTS1670EDA-TR](#) [KTS1640QGDV-TR](#) [KTS1641QGDV-TR](#) [FPF2260ATMX](#) [U6513A](#) [MIC2012YM-TR](#) [TPS2104DBVR](#) [TPS22958NDGKR](#) [MIC2098-1YMT-TR](#) [MIC94062YMT TR](#) [MP6231DN-LF](#) [MIC2015-1.2YM6 TR](#) [MIC2075-2YM](#) [MIC94068YML-TR](#) [SIP32461DB-T2-GE1](#) [NCP335FCT2G](#) [TCK105G,LF\(S\)](#) [AP2411S-13](#) [AP2151DSG-13](#) [AP2172MPG-13](#) [MIC94094YC6-TR](#) [MIC94093YC6-TR](#) [MIC94064YC6-TR](#) [MIC2505-1YM](#) [MIC94305YMT-TR](#) [MIC94085YFT-TR](#) [MIC94081YFT-TR](#) [MIC94042YFL-TR](#) [MIC94041YFL-TR](#) [MIC2005-1.2YM6-TR](#) [TPS2032QDRQ1](#) [NCP333FCT2G](#) [BTS3050TFATMA1](#) [NCP331SNT1G](#) [TPS2092DR](#) [TPS2063DR](#) [VNV35N07-E](#) [MIC2008YML-TR](#) [MIC2040-1YMM](#)