

DESCRIPTION

The MP6513 is an H-bridge motor driver used for driving reversible motors, which can drive one DC motor, one winding of a stepper motor, or other loads. The H-bridge consists of four N-channel power MOSFETs. An internal charge pump generates the necessary gate-drive voltages.

The MP6513 operates on a motor power supply voltage from 2.5V to 21V, which can supply an output current of up to 0.8A according to the logic control.

The MP6513 is controlled by two input pins. The two on/off inputs determine the output mode: forward, reverse, coast, or brake. Very low standby circuit current can be achieved when inputs 1 and 2 are both at a low level.

Full protection features include over-current protection (OCP), short-circuit protection (SCP), under-voltage lockout (UVLO), and over-temperature protection (OTP).

The MP6513 requires a minimum number of readily available, standard, external components and is available in a TSOT23-6 package.

FEATURES

- Wide 2.5V to 21V Operating Input Range
- 0.8A Maximum Output Current
- Low MOSFET On Resistance (HS: 500mΩ; LS: 500mΩ)
- Forward, Reverse, Coast, or Brake Output Modes
- Low Standby Circuit Current when Inputs 1 and 2 are Both Low
- Thermal Shutdown
- Internal Charge Pump
- Cycle-by-Cycle Over-Current Protection (OCP)
- Short-Circuit Protection (SCP)
- Available in a TSOT23-6 Package

APPLICATIONS

- Cameras
- Toys
- Consumer Products
- Medical Devices

All MPS parts are lead-free, halogen-free, and adhere to the RoHS directive. For MPS green status, please visit the MPS website under Quality Assurance. "MPS" and "The Future of Analog IC Technology" are registered trademarks of Monolithic Power Systems, Inc.

TYPICAL APPLICATION

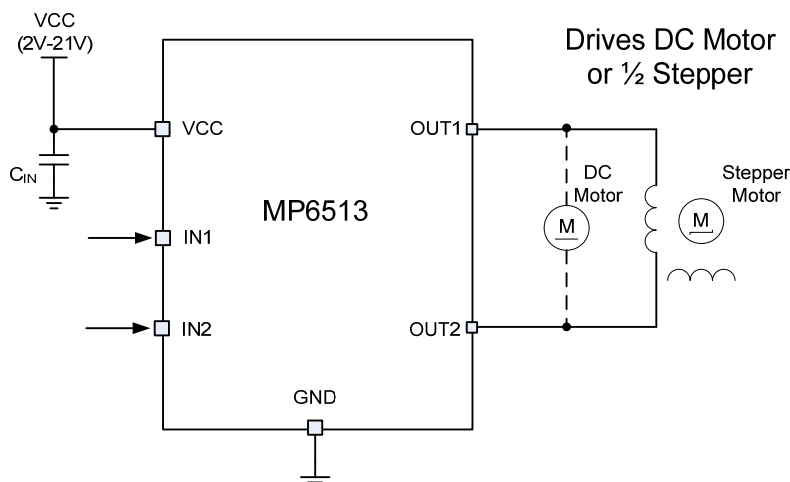

ORDERING INFORMATION

Part Number*	Package	Top Marking
MP6513GJ	TSOT23-6	See Below

* For Tape & Reel, add suffix -Z (e.g. MP6513GJ-Z)

TOP MARKING

|ALPY

ALP: Product code of MP6513GJ
 Y: Year code

PACKAGE REFERENCE

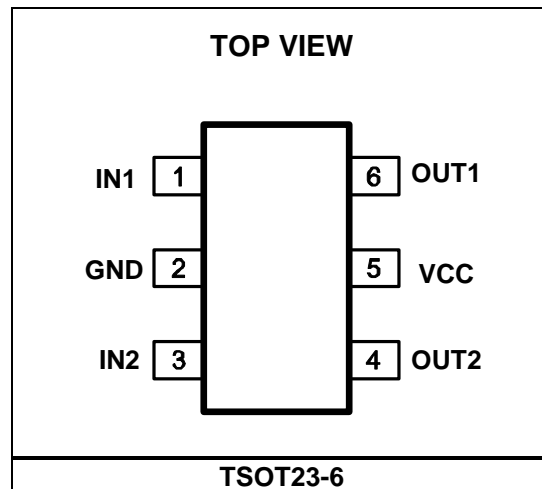

ABSOLUTE MAXIMUM RATINGS ⁽¹⁾

Supply voltage (V _{CC})	-0.3V to +23V
V _{OUTX}	-0.3V to V _{CC} + 0.3V
All other pins	-0.3V to +6V
Continuous power dissipation (T _A = +25°C) ⁽²⁾	
.....	1.14W
Junction temperature	150°C
Lead temperature	260°C
Storage temperature	-60°C to 150°C

Recommended Operating Conditions ⁽³⁾

Supply voltage (V _{CC})	2.5V to 21V
Operating junction temp. (T _J) ...	-40°C to +125°C

Thermal Resistance ⁽⁴⁾	θ_{JA}	θ_{JC}	
TSOT23-6.....	110.....	55.....	°C/W

NOTES:

- 1) Exceeding these ratings may damage the device.
- 2) The maximum allowable power dissipation is a function of the maximum junction temperature T_J (MAX), the junction-to-ambient thermal resistance θ_{JA}, and the ambient temperature T_A. The maximum allowable continuous power dissipation at any ambient temperature is calculated by P_D (MAX) = (T_J (MAX)-T_A)/θ_{JA}. Exceeding the maximum allowable power dissipation produces an excessive die temperature, causing the regulator to go into thermal shutdown. Internal thermal shutdown circuitry protects the device from permanent damage.
- 3) The device is not guaranteed to function outside of its operating conditions.
- 4) Measured on JESD51-7, 4-layer PCB.

ELECTRICAL CHARACTERISTICS

$V_{CC} = 5V$, $T_J = -40^{\circ}C$ to $125^{\circ}C$, unless otherwise noted.

Parameters	Symbol	Condition	Min	Typ	Max	Units
Operating supply current				0.82	1.2	mA
Sleep mode supply current	I_Q	IN1 = 0V, IN2 = 0V		12	20	μA
Under-voltage lockout threshold rising				2.2	2.45	V
Under-voltage lockout threshold hysteresis				150		mV
Input high voltage	V_{IH}		2			V
Input low voltage	V_{IL}				0.8	V
Input high current	I_{IH}	VIN = 3.3V			50	μA
Input low current	I_{IL}	VIN = 0V	-5		5	μA
Input pull-down resistance	R_{PD}			100		k Ω
HS switch on resistance	$R_{DS(ON)}$	IO = 100mA, $T_A = 25^{\circ}C$		0.5	0.6	Ω
LS switch on resistance	$R_{DS(ON)}$	IO = 100mA, $T_A = 25^{\circ}C$		0.5	0.6	Ω
Current limit	I_{OCP}		1		2	A
OCP retry time	T_{OCR}			0.85		ms
Sleep entry time		IN1 = 0V, IN2 = 0V for 2ms		2	5	ms
Sleep recovery time		IN1 or IN2 or both = high level			6.5	μs
Output enable time	$T1^{(6)}$				200	ns
Output disable time	$T2^{(6)}$				260	ns
Delay time	$T3^{(6)}$	INx high to OUTx high			270	ns
	$T4^{(6)}$	INx low to OUTx low			350	ns
Output rise time			30		220	ns
Output fall time			30		170	ns
Dead time				100		ns
Thermal shutdown threshold ⁽⁵⁾	T_{TSD}			160		$^{\circ}C$
Thermal shutdown hysteresis ⁽⁵⁾				25		$^{\circ}C$

NOTES:

5) Guaranteed by design.

6) See Figure 1.

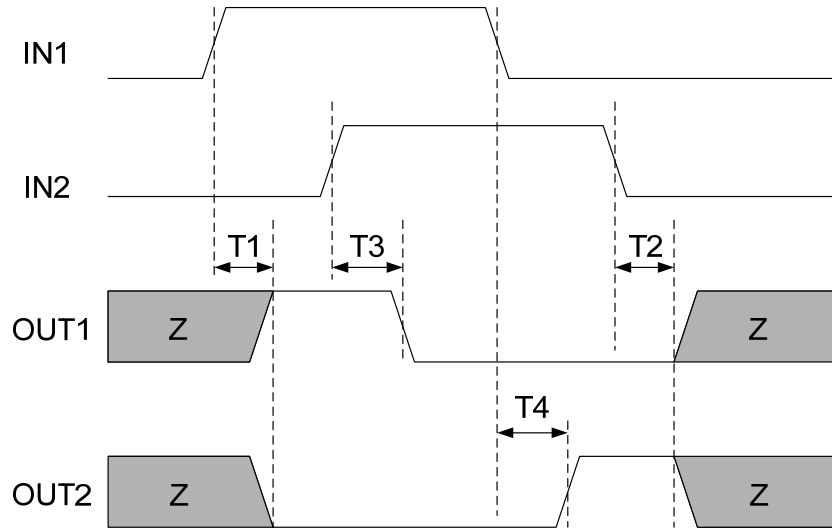
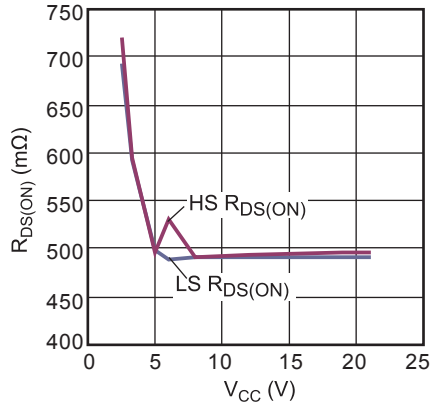

Figure 1: Input/Output Timing

TYPICAL PERFORMANCE CHARACTERISTICS

$V_{CC} = 5V$, $T_A = 25^\circ C$, unless otherwise noted.

$R_{DS(ON)}$ vs. V_{CC}



$R_{DS(ON)}$ vs. Temperature

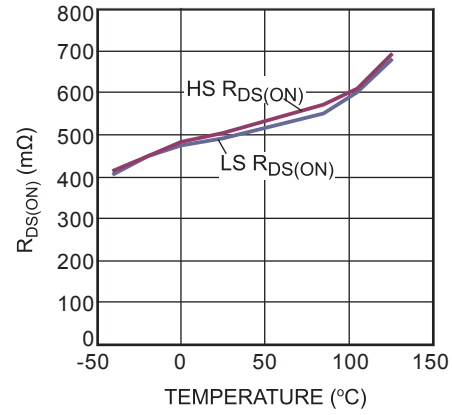

TYPICAL PERFORMANCE CHARACTERISTICS (continued)
 $V_{CC} = 5V, T_A = 25^{\circ}C$, unless otherwise noted.

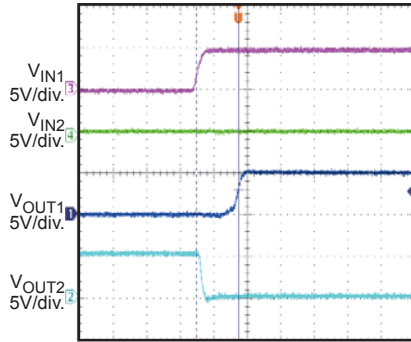
Output Enable Time (T1)
 $V_{CC} = 5V$, No Load

100ns/div.

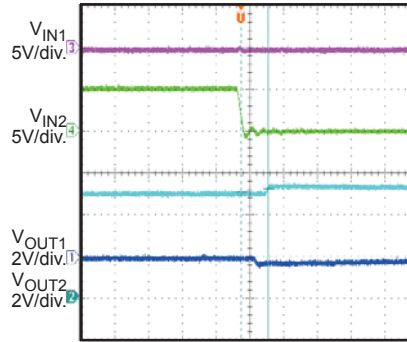
Output Disable Time (T2)
 $V_{CC} = 5V$, No Load

200ns/div.

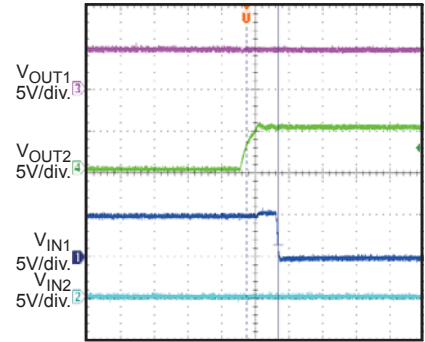
Propagation Delay (T3)
 $V_{CC} = 5V, 21\Omega + 0.2mH$

200ns/div.

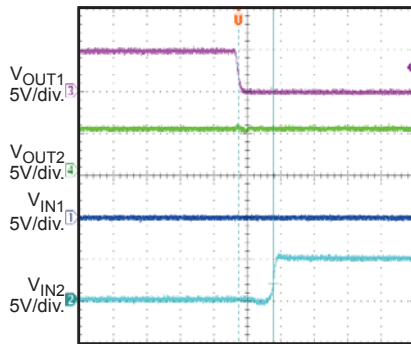
Propagation Delay (T4)
 $V_{CC} = 5V, 21\Omega + 0.2mH$

200ns/div.

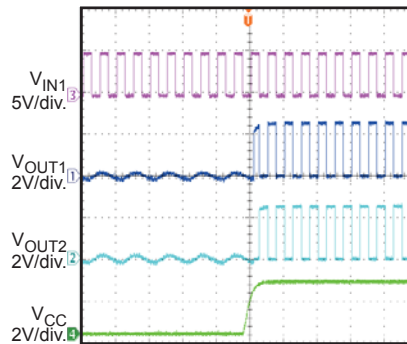
Power Start-Up
 $V_{CC} = 2.5V$, PWM = 100Hz,
No Load

20ms/div.

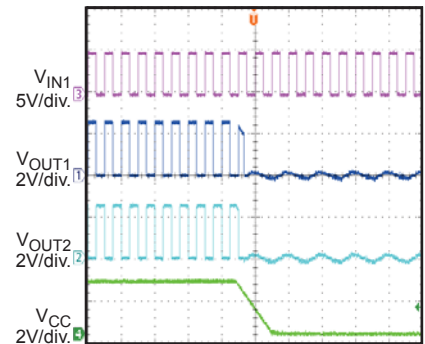
Power Shutdown
 $V_{CC} = 2.5V$, PWM = 100Hz,
No Load

20ms/div.

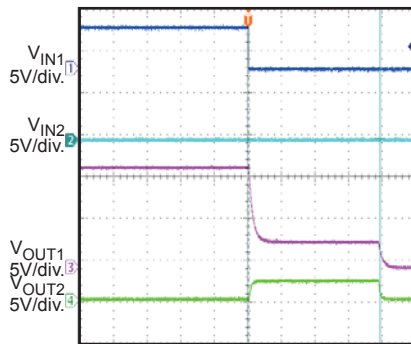
Sleep Mode Entry
 $V_{CC} = 12V, IN1 = IN2 = 0$,
No Load

400μs/div.

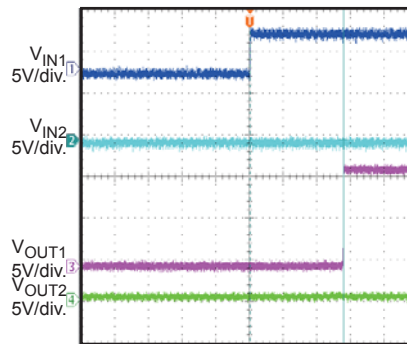
Sleep Mode Recovery
 $V_{CC} = 12V, IN1 = IN2 = H \rightarrow IN1 = H$,
No Load.

2μs/div.

PIN FUNCTIONS

Pin #	Name	Description
1	IN1	Input 1. Internal pull-down resistor.
2	GND	Ground.
3	IN2	Input 2. Internal pull-down resistor.
4	OUT2	Switch output 2. Connect OUT2 to the motor winding.
5	VCC	Supply voltage. An input capacitor is needed to prevent large voltage spikes from appearing at the input.
6	OUT1	Switch output 1. Connect OUT1 to the motor winding.

BLOCK DIAGRAM

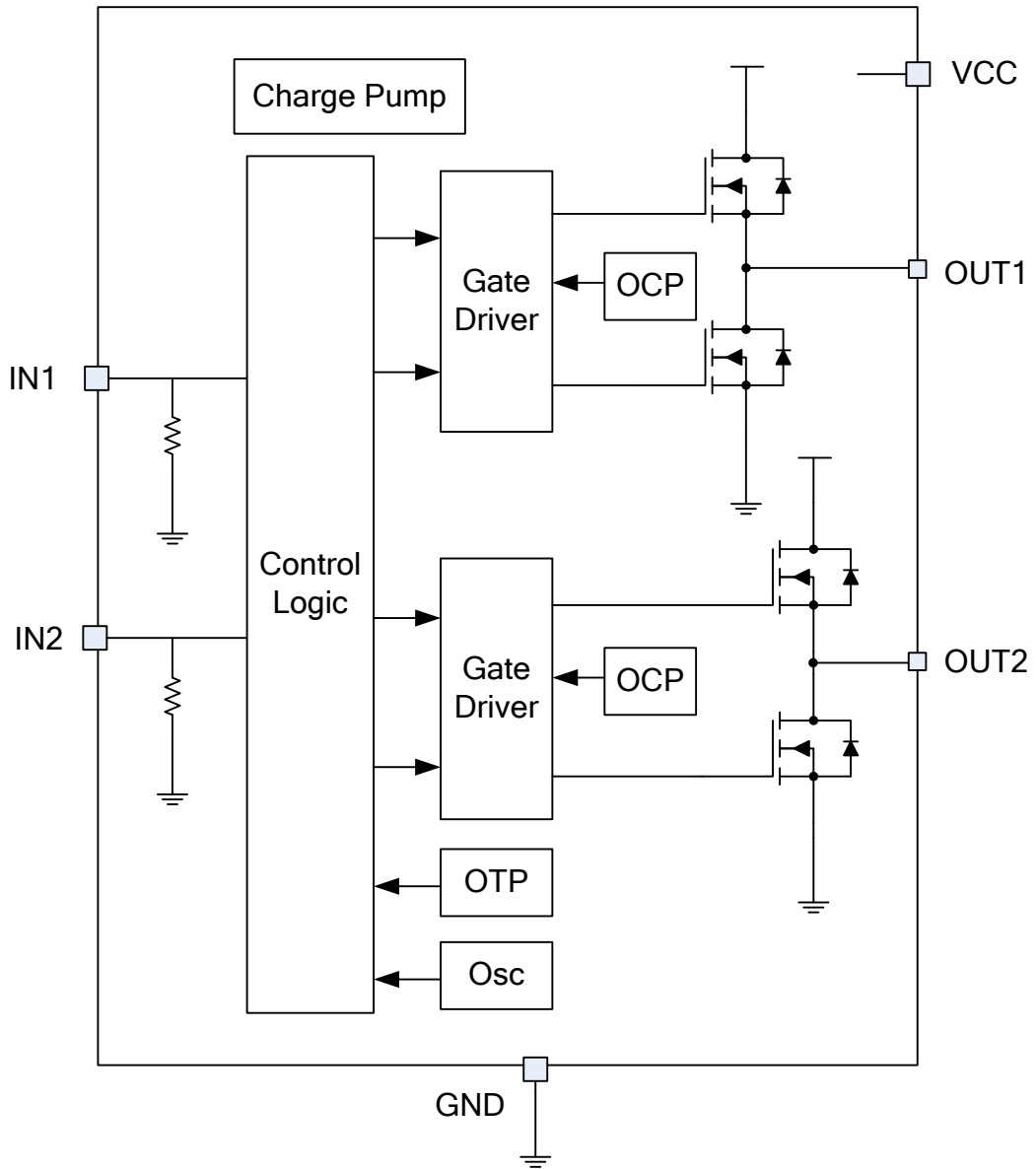

Figure 2: Functional Block Diagram

OPERATION

The MP6513 is an H-bridge motor driver used for driving reversible motors, which can drive one DC motor, one winding of a stepper motor, or other loads. The H-bridge consists of four N-channel power MOSFETs. An internal charge pump generates the necessary gate-drive voltages.

Input Logic

The MP6513 is controlled by two input pins. The two on/off inputs control the output mode: forward, reverse, coast, or brake. Table 1 shows the logic for the MP6513.

Table 1: Input Logic Truth Table

IN1	IN2	OUT1	OUT2	Function (DC Motor)
L	L	Z	Z	Coast
L	H	L	H	Reverse
H	L	H	L	Forward
H	H	L	L	Brake

Sleep Mode

If the input pins (IN1 and IN2) both remain at a low level within a certain time, the part enters a low-power sleep mode. In this state, all unnecessary internal circuitries are powered down.

Over-Current Protection (OCP)

The MP6513 has internal overload and short-circuit protection. The currents in both the high-side and low-side MOSFETs are measured. If the current exceeds the current limit, all MOSFETs in the H-bridge are turned off. The bridge is re-enabled after approximately 1ms automatically.

Thermal Shutdown (TSD)

Thermal monitoring is integrated into the MP6513. If the die temperature rises above 160°C, all switches are turned off. Once the die temperature has fallen back to a safe level, operation resumes automatically.

Under-Voltage Lockout (UVLO)

If at any time the voltage on VCC falls below the under-voltage lockout threshold voltage, all circuitries in the device are disabled, and the internal logic is reset. Operation resumes when VCC rises above the UVLO threshold.

Power Dissipation and Recommended Junction Temperature

The recommended maximum junction temperature is 125°C under normal operating conditions. To ensure that the junction temperature is within this limit, calculate the maximum allowable dissipation ($P_{D(MAX)}$) with Equation (1):

$$P_{D(MAX)} = (T_J(max) - T_A) / \theta_{JA} \quad (1)$$

Where $T_J(max)$ is the maximum recommended operation junction temperature (125°C), θ_{JA} is the junction-to-ambient thermal resistance, and T_A is the ambient temperature (see Table 2).

Table 2: Dissipation Ratings

Package	θ_{JA} (°C/W)	Dissipation Power Rating		
		$T_A = 25^\circ\text{C}$	$T_A = 50^\circ\text{C}$	$T_A = 85^\circ\text{C}$
TSOT23-6	110	0.9W	0.65W	0.35W

PACKAGE INFORMATION

TSOT23-6

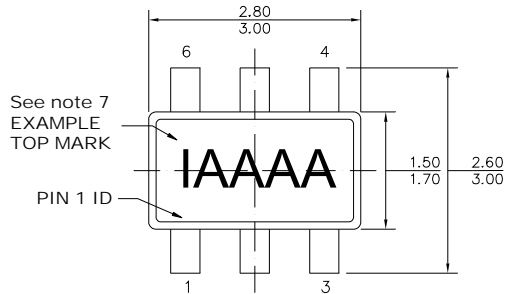

TOP VIEW

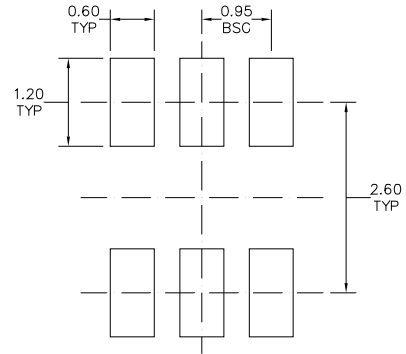

RECOMMENDED LAND PATTERN

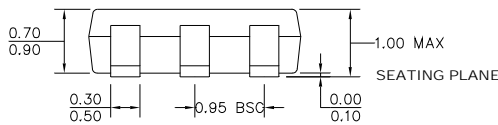

FRONT VIEW

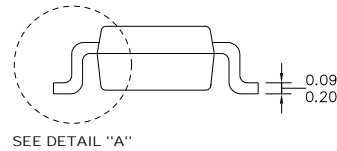

SIDE VIEW

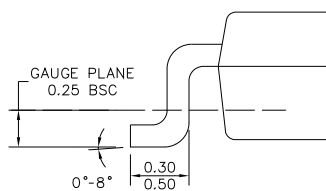

DETAIL "A"

NOTE:

- 1) ALL DIMENSIONS ARE IN MILLIMETERS.
- 2) PACKAGE LENGTH DOES NOT INCLUDE MOLD FLASH, PROTRUSION OR GATE BURR.
- 3) PACKAGE WIDTH DOES NOT INCLUDE INTERLEAD FLASH OR PROTRUSION.
- 4) LEAD COPLANARITY (BOTTOM OF LEADS AFTER FORMING) SHALL BE 0.10 MILLIMETERS MAX.
- 5) DRAWING CONFORMS TO JEDEC MO-193, VARIATION AB.
- 6) DRAWING IS NOT TO SCALE.
- 7) PIN 1 IS LOWER LEFT PIN WHEN READING TOP MARK FROM LEFT TO RIGHT (SEE EXAMPLE TOP MARK).

NOTICE: The information in this document is subject to change without notice. Please contact MPS for current specifications. Users should warrant and guarantee that third party Intellectual Property rights are not infringed upon when integrating MPS products into any application. MPS will not assume any legal responsibility for any said applications.

X-ON Electronics

Largest Supplier of Electrical and Electronic Components

Click to view similar products for [Motor/Motion/Ignition Controllers & Drivers](#) category:

Click to view products by [Monolithic Power Systems](#) manufacturer:

Other Similar products are found below :

[FSB50550TB2](#) [FSBF15CH60BTH](#) [MSVCPM2-63-12](#) [MSVGW45-14-2](#) [MSVGW54-14-3](#) [MSVGW54-14-5](#) [NTE7043](#) [LA6565VR-TLM-E](#)
[LB11650-E](#) [LB1837M-TLM-E](#) [LB1845DAZ-XE](#) [LC898300XA-MH](#) [SS30-TE-L-E](#) [26700](#) [LV8281VR-TLM-H](#) [BA5839FP-E2](#) [IRAM236-1067A](#) [LA6584JA-AH](#) [LB11847L-E](#) [NCV70501DW002R2G](#) [AH293-PL-B](#) [STK672-630CN-E](#) [TND315S-TL-2H](#) [FNA23060](#) [FSB50250AB](#)
[FNA41060](#) [MSVB54](#) [MSVBTC50E](#) [MSVCPM3-54-12](#) [MSVCPM3-63-12](#) [MSVCPM4-63-12](#) [MSVTA120](#) [FSB50550AB](#)
[NCV70501DW002G](#) [LC898301XA-MH](#) [LV8413GP-TE-L-E](#) [MSVGW45-14-3](#) [MSVGW45-14-4](#) [MSVGW45-14-5](#) [MSVGW54-14-4](#)
[STK984-091A-E](#) [MP6519GQ-Z](#) [LB11651-E](#) [IRSM515-025DA4](#) [LV8127T-TLM-H](#) [MC33812EKR2](#) [NCP81382MNTXG](#) [TDA21801](#)
[LB11851FA-BH](#) [NCV70627DQ001R2G](#)