

DESCRIPTION

The MPM3570E is a high density, non-isolated, DC/DC power module for space-sensitive applications. It offers a very compact solution that achieves 0.3A of output current over a wide 4.5V to 75V input supply range and can provide an adjustable output voltage from 1.0V to 12V via an external FB resistor (default 3.3V output).

The MPM3570E integrates a switching controller, power switches, inductors, a modest amount of input and output capacitors, and all supporting components in a small package size. This compact solution helps system design and production significantly by offering a greatly simplified board design, layout, and manufacturing requirements.

Ultra-high efficiency is achieved through synchronous rectification and control techniques, especially under light-load conditions. A 25 μ A shutdown quiescent current in the full temperature range is optimal for battery-powered applications.

The MPM3570E offers standard features, including internal fixed soft start (SS), remote enable (EN) control, and power OK indication (POK). Full protection features include over-current protection (OCP), under-voltage lockout (UVLO), and thermal shutdown.

The MPM3570E requires a minimal number of external components and is available in a compact LGA8 (10mmx10mmx4.2mm) package.

FEATURES

- Integrated Inductor, Switches, and Controller
- High Efficiency, Synchronous
- Low Component Count and Small Size
- Ease of Design and Fastest Time to Market
- Wide 4.5V to 75V Operating Input Range
- Output Adjustable from 1V to 12V
- 0.3A Output Current
- 40 μ A Quiescent Current
- Ultra-Fast Transient Response
- Internal Fixed Soft-Start (SS) Time
- Power OK Indicator (POK)
- Non-Latch Over-Current Protection (OCP) and Under-Voltage Lockout (UVLO)
- Thermal Shutdown Protection
- Remote Enable (EN) Control
- Weight: 0.80g
- Operating Temperature: -40°C to +125°C
- CISPR25 Class 5 Compliant
- Available in a LGA8 (10mmx10mmx4.2mm) Package

APPLICATIONS

- Automotive Systems
- Industrial Supplies
- Telecom and Networking Systems
- Distributed Power and POL Systems

All MPS parts are lead-free and adhere to the RoHS directive. For MPS green status, please visit MPS website under Products, Quality Assurance page.

"MPS" and "The Future of Analog IC Technology" are registered trademarks of Monolithic Power Systems, Inc.

TYPICAL APPLICATION

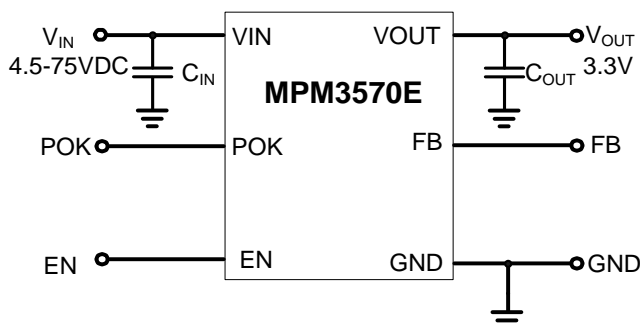

Efficiency

V_{OUT}=3.3V

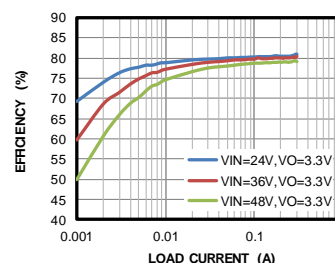

ORDERING INFORMATION

Part Number*	Package	Top Marking
MPM3570EGLD	LGA-8 (10mmx10mmx4.2mm)	See Below

* For Tape & Reel, add suffix -Z (e.g. MPM3570EGLD-Z).

TOP MARKING

MPS YYWW
MPM3570E
LLLLLLLLLL

MPS: MPS prefix
 YY: Year code
 WW: Week code
 MPM3570E: First eight digits of the part number
 LLLLLLLLLL: Lot number

PACKAGE REFERENCE

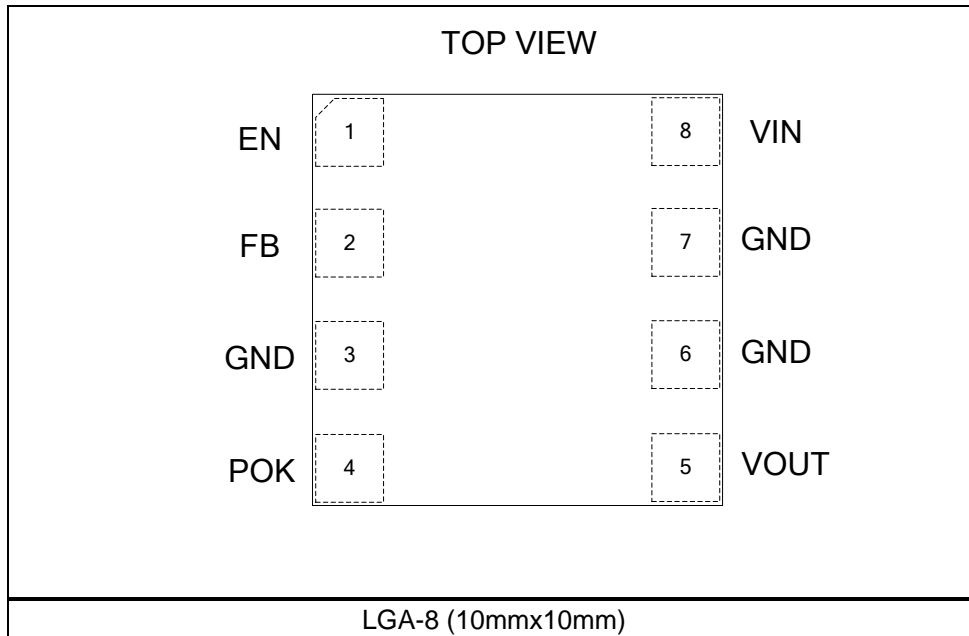

PIN FUNCTIONS

PIN #	Name	Description
1	EN	Enable. Drive EN high to turn on the module, and drive it low to turn off the module.
2	FB	Feedback point. The MPM3570E regulates its FB pin to 1V. Connect an external resistor (R_{FB1}) from FB to VOUT to set the output voltage (for an output voltage smaller than 3.3V). For output voltage larger than 3.3V, connect an external resistor (R_{FB2}) from FB to GND.
3, 6, 7	GND	Ground.
4	POK	Power OK indication. The output of POK will go HIGH if the output voltage exceeds 90% of the rated voltage. It will drop down if the output voltage is less than 84% of the rated voltage.
5	VOUT	Output voltage. VOUT is connected to the internal power inductor and output capacitor. Connect VOUT to the output load and connect external bypass capacitors between VOUT and pin 6 if needed.
8	VIN	Input voltage. VIN supplies all power to the module. Connect VIN to the input supply and connect external bypass capacitors of at least 4.7 μ F between VIN and pin 7.

ABSOLUTE MAXIMUM RATINGS ⁽¹⁾

VIN -0.3V to +80V

All other pins -0.3V to +6.0V

Continuous power dissipation ($T_A = +25^\circ\text{C}$) ⁽²⁾

LGA8 (10mmx10mmx4.2mm) 2.5W

Junction temperature 150 $^\circ\text{C}$

Lead temperature 260 $^\circ\text{C}$

Storage temperature -65 $^\circ\text{C}$ to 150 $^\circ\text{C}$

Recommended Operating Conditions ⁽³⁾

Continuous supply voltage (VIN) 4.5V to 75V

Output voltage (VOUT) 1.0V to 12.0V

Operating temperature (T_O) -40 $^\circ\text{C}$ to +125 $^\circ\text{C}$

Thermal Resistance ⁽⁴⁾ θ_{JA} θ_{JC}
 LGA-8 (10mmx10mm) 50..... 20... $^\circ\text{C/W}$

NOTES:

- 1) Absolute maximum ratings are rated under room temperature unless otherwise noted. Exceeding these ratings may damage the device.
- 2) The maximum allowable power dissipation is a function of the maximum junction temperature T_J (MAX), the junction-to-ambient thermal resistance θ_{JA} , and the ambient temperature T_A . The maximum allowable continuous power dissipation at any ambient temperature is calculated by P_D (MAX) = $(T_J$ (MAX) - T_A) / θ_{JA} . Exceeding the maximum allowable power dissipation produces an excessive die temperature, causing the module to go into thermal shutdown. Internal thermal shutdown circuitry protects the device from permanent damage.
- 3) The device is not guaranteed to function outside of its operating conditions.
- 4) θ_{JA} : the thermal resistance from junction-to-ambient. This is the natural convection junction-to-ambient air thermal resistance measured in a one cubic foot sealed enclosure.
 θ_{JC} : the thermal resistance from junction to the metal lid of the module. This is the junction-to-board thermal resistance with all of the component power dissipation flowing through the entire package.

ELECTRICAL CHARACTERISTICS

$V_{IN} = 12V$, External $C_{IN}=2 \times 4.7\mu F$, $C_{OUT}=2 \times 22\mu F$, $T_A = -40^\circ C$ to $+125^\circ C$, unless otherwise noted.

Parameters	Symbol	Condition	Min	Typ	Max	Units
Input Voltage and Current						
Input DC voltage range	V_{IN}		4.5		75	V
Maximum input current	I_{IN-MAX}	$I_{OUT} = 0.3A$, $V_{OUT} = 3.3V$		110		mA
Input current (shutdown)	I_{IN}	$V_{EN} = 0V$		15	25	μA
Input current (quiescent)	I_{IN}	Enabled, no load, $V_{OUT} = 3.3V$		18	40	μA
Input Under-Voltage Lockout						
VIN UVLO rising threshold			3.85	4.2	4.5	V
VIN UVLO falling threshold			3.35	3.75	4.15	V
Output Voltage and Current						
Output range	V_{OUT}	Via an external FB resistor	1.0	3.3	5.0	V
Output voltage precision ⁽⁵⁾		Output 3.3V, over all supply voltage, load current, $T_A=25^\circ C$	-2.0		+2.0	%
		Output 3.3V, over all supply voltage, load current and temperature range	-3.0		+3.0	%
Output regulation ($V_{OUT}=3.3V$) ⁽⁵⁾		Line regulation ($V_{IN} = 4.5V$ to $75V$, $I_{OUT} = 0A$), $T_A=25^\circ C$	-2.0		+2.0	%
		Load regulation ($I_{OUT} = 0A$ to $0.3A$), $T_A=25^\circ C$	-2.0		+2.0	%
Output regulation ($V_{OUT}=5V$) ⁽⁵⁾		Line regulation ($V_{IN} = 4.5V$ to $75V$, $I_{OUT} = 0A$), $T_A=25^\circ C$	-2.0		+2.0	%
		Load regulation ($I_{OUT} = 0A$ to $0.3A$), $T_A=25^\circ C$	-2.0		+2.0	%
Output ripple ($V_{OUT}=3.3V$) ⁽⁵⁾	$V_{OUT(AC)}$	$V_{IN} = 12V$, $I_{OUT}=0.3A$, $T_A=25^\circ C$		30		mV
		$V_{IN} = 24V$, $I_{OUT}=0.3A$, $T_A=25^\circ C$		25		mV
Output ripple ($V_{OUT}=5V$) ⁽⁵⁾	$V_{OUT(AC)}$	$V_{IN} = 12V$, $I_{OUT}=0.3A$, $T_A=25^\circ C$		30		mV
		$V_{IN} = 24V$, $I_{OUT}=0.3A$, $T_A=25^\circ C$		25		mV
Output current range	I_{OUT}		0		0.3	A

ELECTRICAL CHARACTERISTICS (continued)
 $V_{IN} = 12V$, External $C_{IN} = 2 \times 4.7\mu F$, $C_{OUT} = 2 \times 22\mu F$, $T_A = -40^\circ C$ to $+125^\circ C$, unless otherwise noted.

Parameters	Symbol	Condition	Min	Typ	Max	Units
Output Turn-On Delay and Rise Time						
Turn-on delay time	T_{DELAY}	$I_{OUT} = 0A$, from EN high to 10% of the rated V_{OUT}		0.9		ms
Rise time	T_{RISE}	$I_{OUT} = 0A$, from 10% to 90% of the rated V_{OUT}		1.4		ms
Efficiency						
Efficiency ($V_{OUT} = 3.3V$) ⁽⁵⁾	η	$V_{IN} = 12V, I_{OUT} = 0.15A, T_A = 25^\circ C$		85.5		%
		$V_{IN} = 24V, I_{OUT} = 0.15A, T_A = 25^\circ C$		85.2		%
Efficiency ($V_{OUT} = 5V$) ⁽⁵⁾	η	$V_{IN} = 12V, I_{OUT} = 0.15A, T_A = 25^\circ C$		88.5		%
		$V_{IN} = 24V, I_{OUT} = 0.15A, T_A = 25^\circ C$		88.2		%
Frequency						
Switching frequency ⁽⁵⁾	f_{SW}	$I_{OUT} = 0.3A, V_{OUT} = 3.3V, T_A = 25^\circ C$		140		kHz
		$I_{OUT} = 0.3A, V_{OUT} = 5V, T_A = 25^\circ C$		165		kHz
EN (Active High)						
EN input rising threshold	$V_{EN-RISING}$		1.35	1.6	1.85	V
EN input falling threshold	$V_{EN-FALLING}$		1.1	1.2	1.3	V
EN threshold hysteresis	V_{EN-HYS}			400		mV
POK						
POK rising threshold	$POK_{Vth-Rising}$		86%	90%	94%	V_{FB-REF}
POK falling threshold	$POK_{Vth-Falling}$		80%	84%	88%	V_{FB-REF}
POK deglitch time	t_{POK}			40		μs
POK default voltage	V_{POK}	$V_{OUT} = 3.3V$		3.28		V
Thermal Protection						
Thermal shutdown ⁽⁵⁾	T_{SD}			175		$^\circ C$
Thermal shutdown hysteresis ⁽⁵⁾	T_{SD-HYS}			20		$^\circ C$

Note:

5) Derived from bench characterization, not tested in production.

TYPICAL PERFORMANCE CHARACTERISTICS

$V_{IN} = 12V$, $V_{OUT} = 3.3V$, External $C_{IN}=2 \times 4.7\mu F$, $C_{OUT}=2 \times 22\mu F$, $T_A = 25^\circ C$, unless otherwise noted.

Efficiency

$V_{OUT}=3.3V$

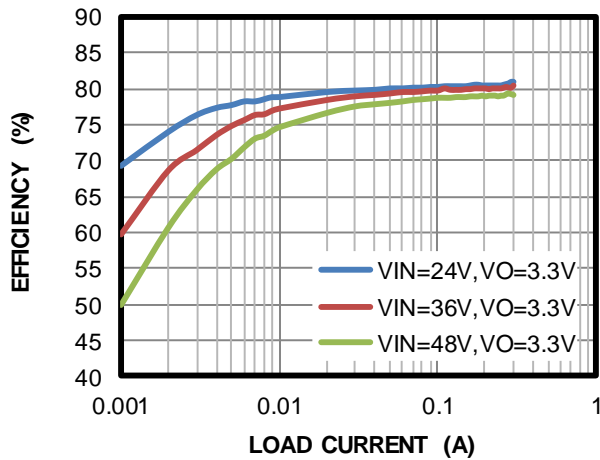

Efficiency

$V_{OUT}=5.5V$

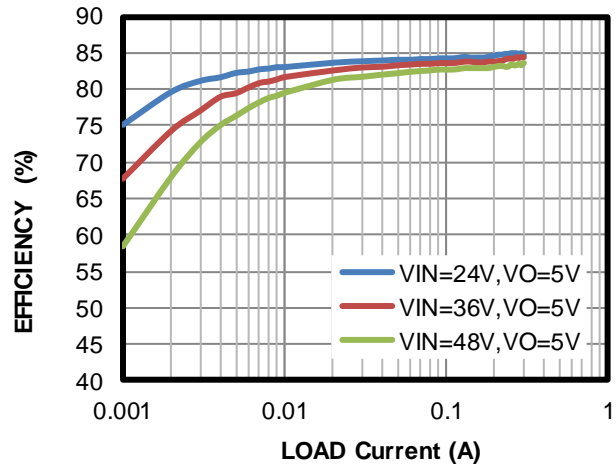

Line Regulation vs. Vin

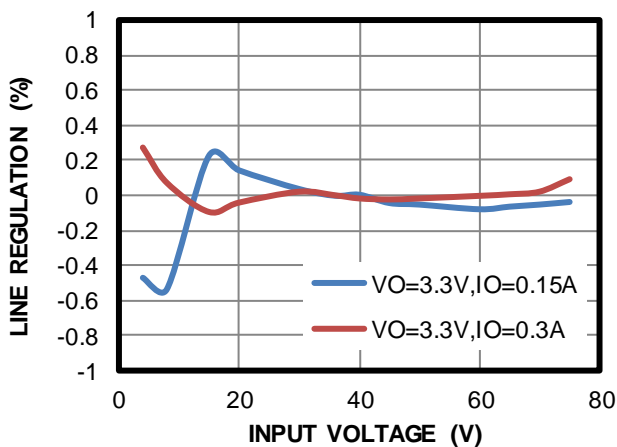

Line Regulation vs. Vin

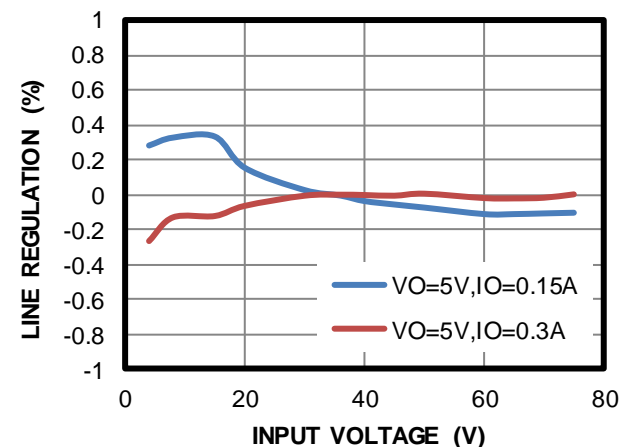

Load Regulation vs. Iout

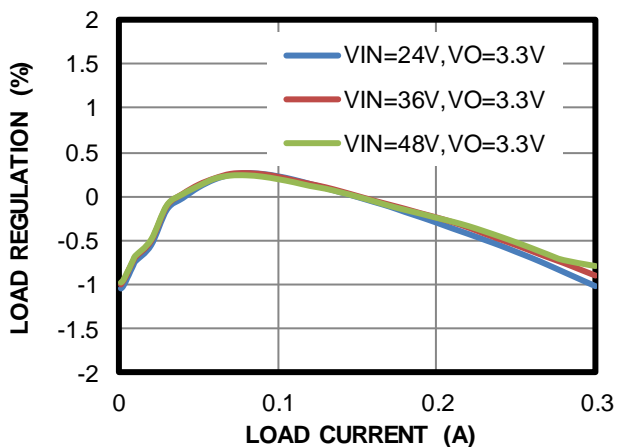

Load Regulation vs. Iout

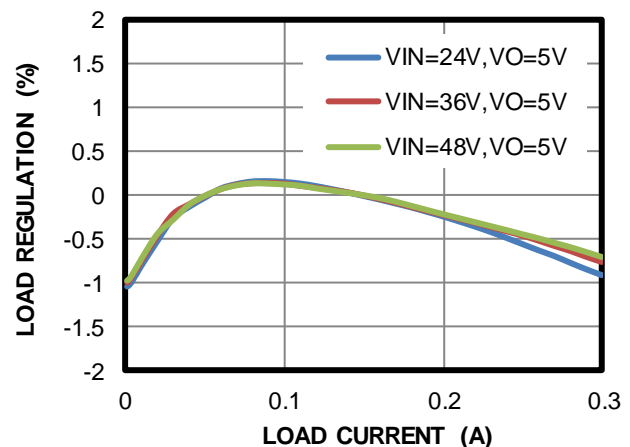

TYPICAL PERFORMANCE CHARACTERISTICS

$V_{IN} = 12V$, $V_{OUT} = 3.3V$, External $C_{IN} = 2 \times 4.7\mu F$, $C_{OUT} = 2 \times 22\mu F$, $T_A = 25^\circ C$, unless otherwise noted.

Thermal Derating

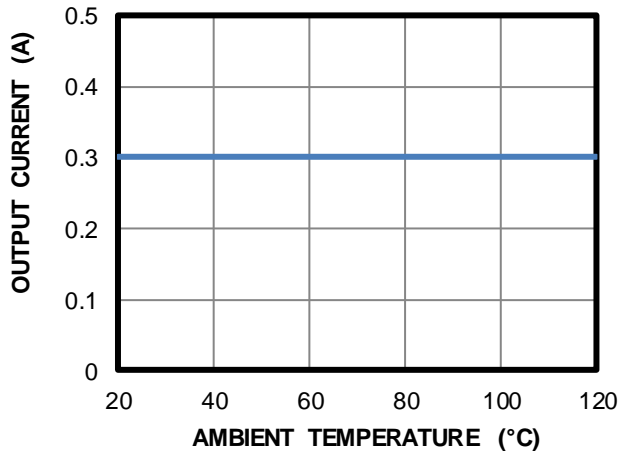

With External EMI Filter: 10 μ F+4.7 μ H, External COUT=1 \times 22 μ F, Io=0.3A (CISPR25 Class 5)

Radiated Emissions Performance

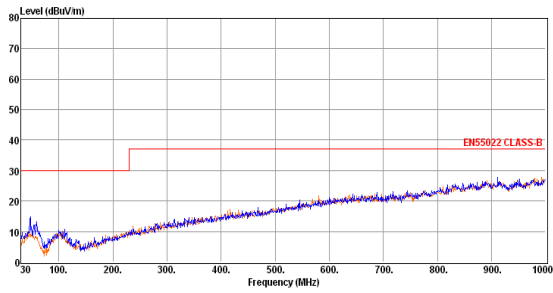

Conducted Emissions Performance

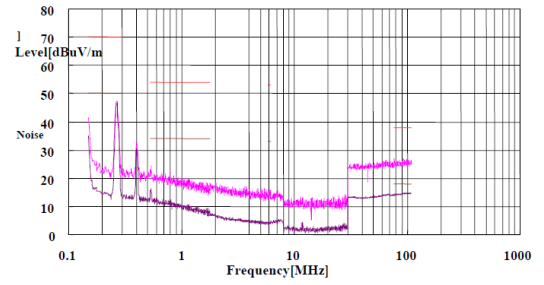

EMI Filter Circuit

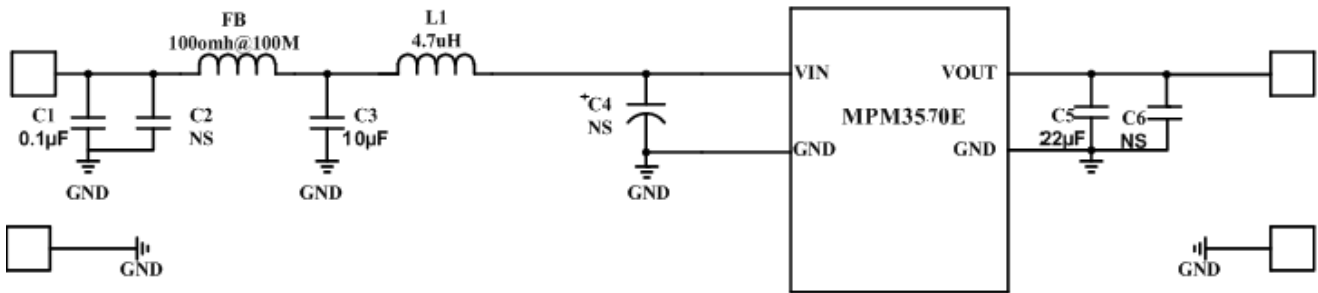

TYPICAL PERFORMANCE CHARACTERISTICS

$V_{IN} = 12V$, $V_{OUT} = 3.3V$, External $C_{IN}=2 \times 4.7\mu F$, $C_{OUT}=2 \times 22\mu F$, $T_A = 25^\circ C$, unless otherwise noted.

Vo Ripple

$I_{OUT}=0A$

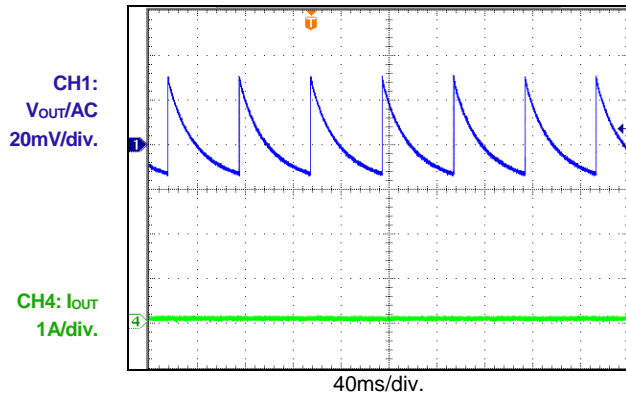

Vo Ripple

$I_{OUT}=0.3A$

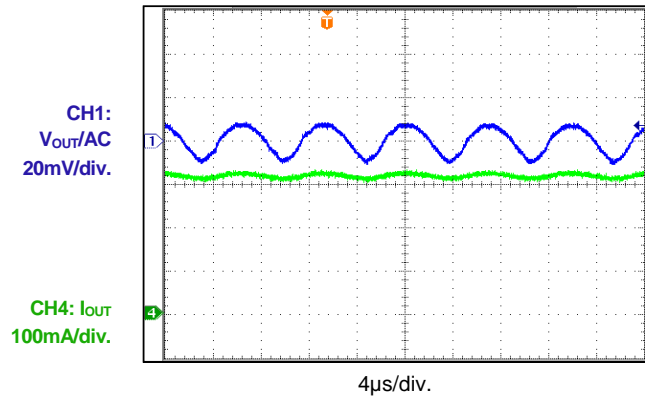

Vin Start-Up

$I_{OUT}=0A$

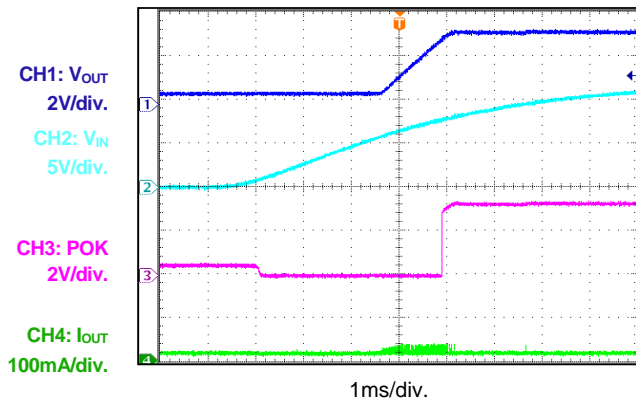

Vin Start-Up

$I_{OUT}=0.3A$

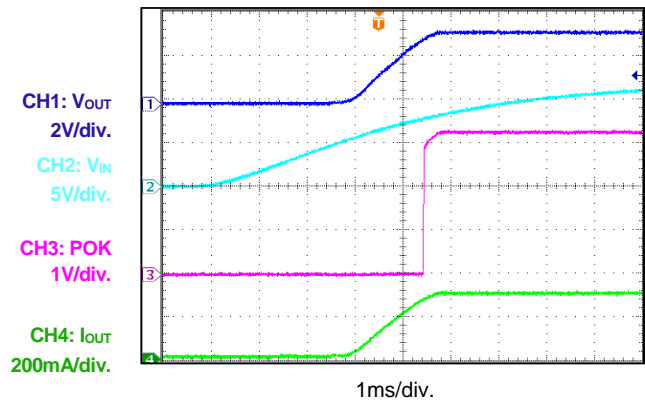

Vin Shutdown

$I_{OUT}=0A$

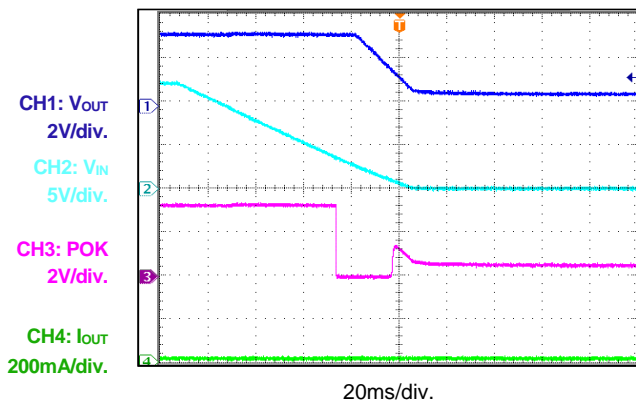

Vin Shutdown

$I_{OUT}=0.3A$

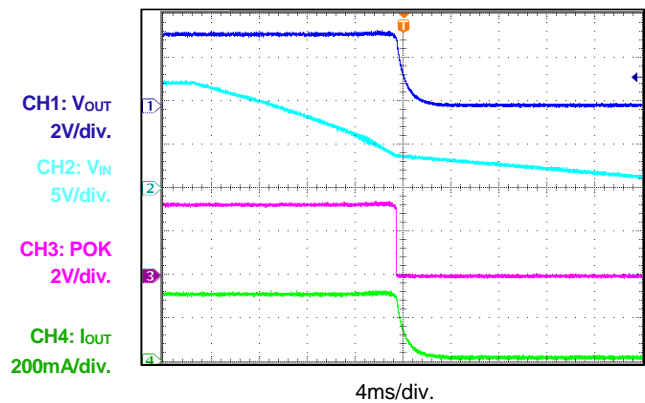

TYPICAL PERFORMANCE CHARACTERISTICS (continued)

$V_{IN} = 12V$, $V_{OUT} = 3.3V$, External $C_{IN} = 2 \times 4.7\mu F$, $C_{OUT} = 2 \times 22\mu F$, $T_A = 25^\circ C$, unless otherwise noted.

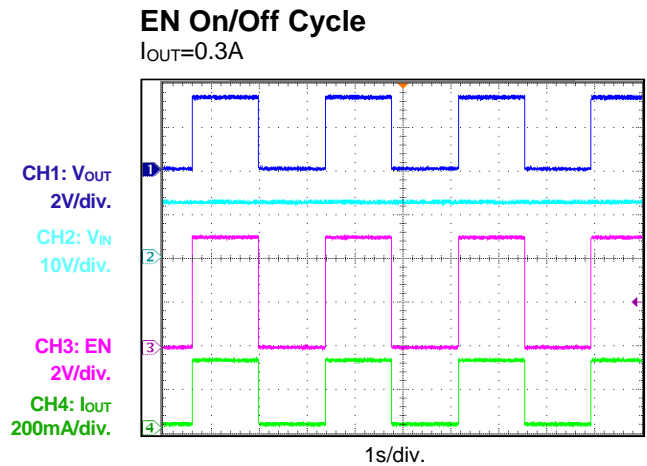
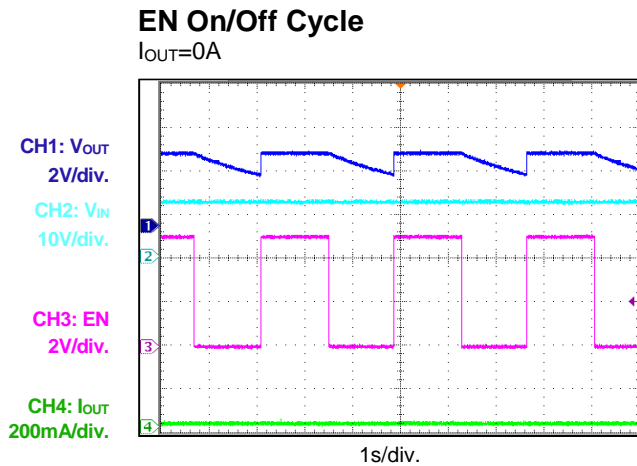
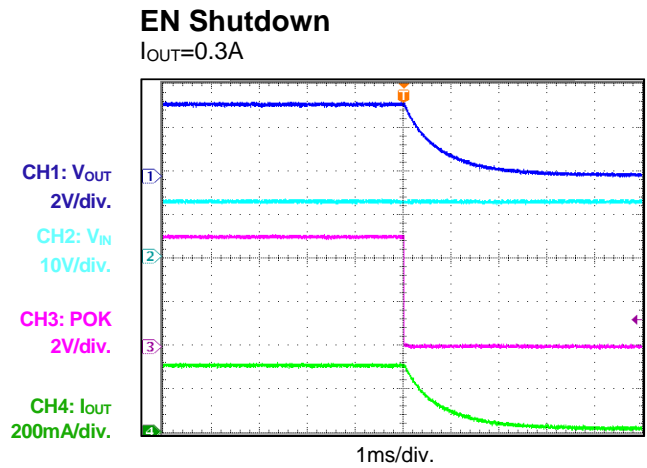
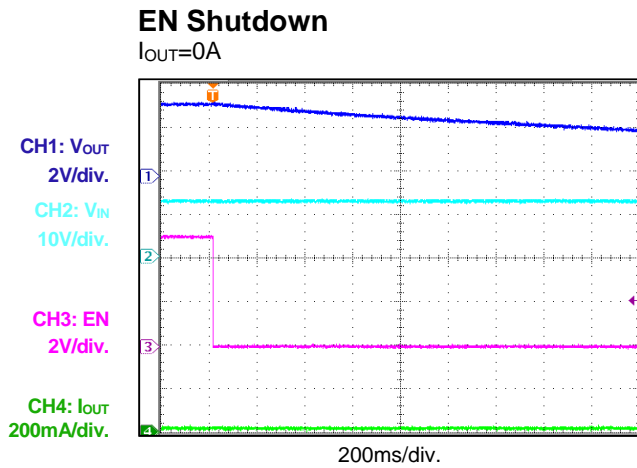
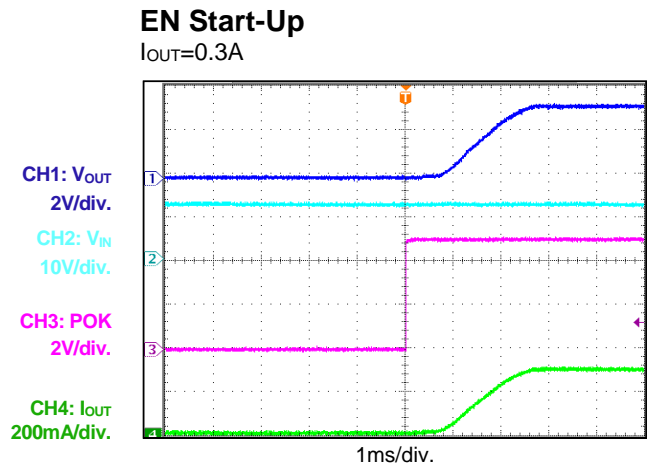
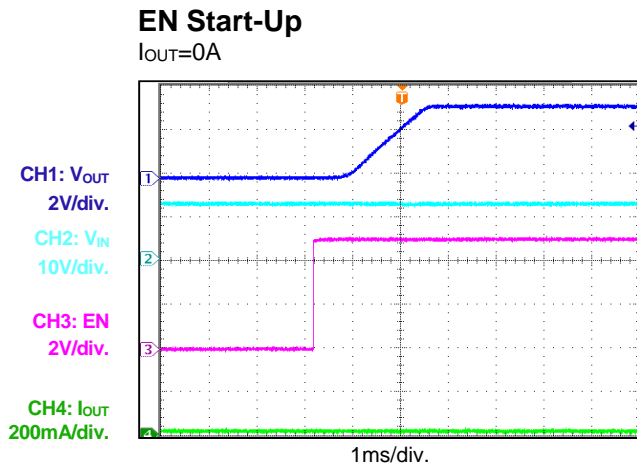

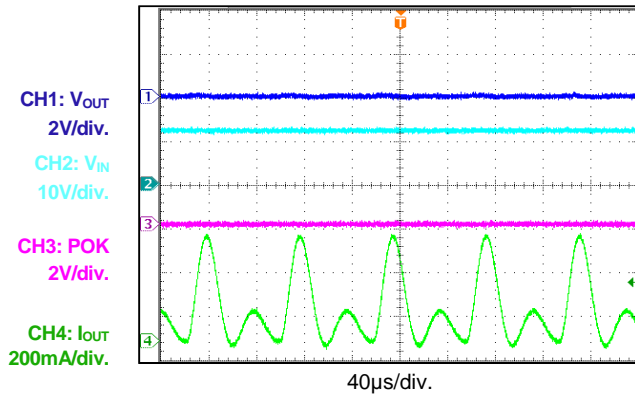
TYPICAL PERFORMANCE CHARACTERISTICS *(continued)* $V_{IN} = 12V$, $V_{OUT} = 3.3V$, External $C_{IN} = 2 \times 4.7\mu F$, $C_{OUT} = 2 \times 22\mu F$, $T_A = 25^\circ C$, unless otherwise noted.**SCP Steady State**

BLOCK DIAGRAM

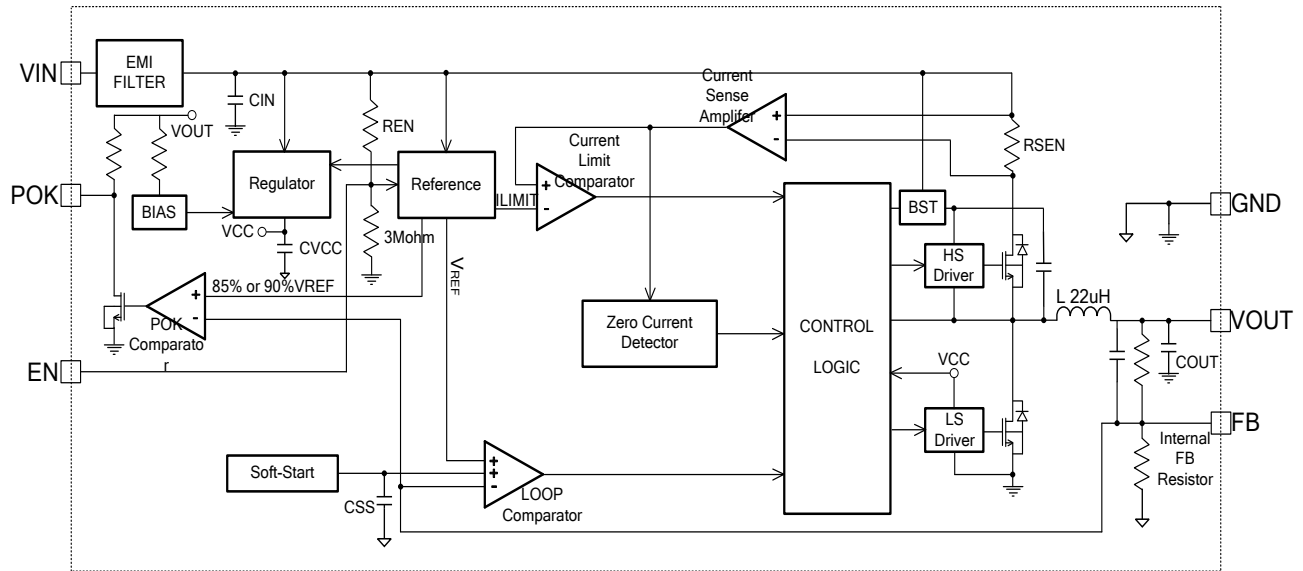

Figure 1: Functional Block Diagram

OPERATION

The MPM3570E is a fully integrated, synchronous, rectified, step-down, non-isolated switch-mode power module. A block diagram of the device is shown in Figure 1. It is available with a 4.5V to 75V wide input supply range and can achieve 0.3A continuous output current over an ambient temperature range of -40°C to $+125^{\circ}\text{C}$. This module provides a default 3.3V output voltage and can be adjusted to a range of 1.0V to 12.0V output via an external FB resistor.

Enable Control

The MPM3570E can be enabled or disabled via a remote EN signal, which is referenced to ground. The remote EN control operates with positive logic, which is compatible with popular logic devices. Positive logic implies that the converter is enabled if the EN signal goes high, and disabled if the EN signal goes low. Its rising threshold is 1.6V, and the trailing threshold is about 400mV lower.

When EN = 0V, the module goes into the lowest shutdown current mode. When EN is higher than zero, but lower than its rising threshold, the module remains in shutdown mode with a slightly larger shutdown current.

EN is connected to the VIN through a pull-up resistor internally, allowing the user to enable the device with this pin floating. If an application requires remote EN control, use a suitable logic device to interface with EN.

An internal 6.5V Zener diode on EN clamps the pin voltage to prevent runaway. Therefore, when driving EN directly with an external logic signal, use a signal voltage less than 6V to prevent damage to the Zener diode.

Internal Soft Start

Soft start ramps VOUT gradually during start-up to prevent overshoot. When the module starts up, the internal circuitry generates a soft-start voltage (V_{SS}), which ramps up at a slow pace set by the soft-start time. When V_{SS} is lower than V_{REF} , V_{SS} takes over V_{REF} as the reference to the FB comparator. Once V_{SS} exceeds V_{REF} , V_{REF} resumes control. At this point, soft start finishes, and the MPM3570E enters steady state. The soft-start time is set to about 1.4ms internally.

If V_{FB} drops, V_{SS} tracks V_{FB} . This function prevents output voltage from overshooting in

short-circuit recovery. When the short circuit is removed, the V_{SS} ramps up as if it is a fresh soft-start process.

Power OK Indicator

The MPM3570E has a power OK (POK) indicator. POK is the open drain of a MOSFET, and it is connected to V_{OUT} internally through a 100k Ω resistor. In the presence of an input voltage, the MOSFET turns on so that POK is pulled to GND before the soft start is ready. After V_{FB} reaches $90\% \times V_{REF}$, POK is pulled high after a delay. When V_{FB} drops to $84\% \times V_{REF}$, POK will be pulled low. The default voltage of POK is the same as V_{OUT} . If another voltage is needed for compatibility, an appropriate resistor can be placed between POK and GND or an external voltage source.

Over-Current Protection (OCP)

The MPM3570E is equipped with an internal current limit, which can provide over-current protection (OCP) in an over-current fault condition. This is very helpful to reduce the OCP thermal dissipation, which may worsen when the output voltage is shorted.

Input UVLO protection

The MPM3570E has under-voltage lockout protection (UVLO) to ensure reliable output power. This function prevents the module from operating when the input voltage is too low. UVLO is a non-latch protection.

Thermal Shutdown

The module has thermal protection by monitoring the junction temperature of the internal IC. This function prevents the device from operating at an exceedingly high temperature. If the junction temperature exceeds the threshold value (175°C), it shuts down the whole device. This is a non-latch protection. There is about a 20°C hysteresis. Once the junction temperature drops to about 155°C , the module resumes operation by initiating a soft start.

APPLICATION INFORMATION

Output Voltage Setting

The MPM3570E has an internal FB divider to set a default 3.3V output voltage. The upper divider resistor is 1.2M Ω , and the lower divider resistor is 523k Ω (see Figure 2).

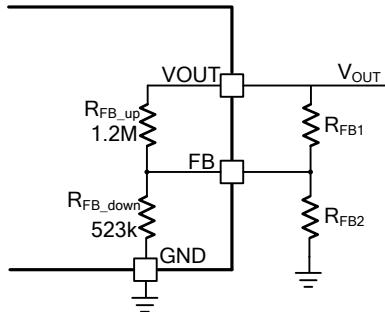

Figure 2: Adjusting Output with FB Resistors

The MPM3570E regulates FB to 1V. By connecting an external trim resistor, the output can be set to any voltage from 1.0V to 5.0V. For a V_{OUT} less than 3.3V, connect an appropriate resistor (R_{FB1}) between FB and V_{OUT} . For a V_{OUT} over 3.3V, connect an appropriate resistor (R_{FB2}) between FB and GND. These two resistors can be calculated with Equation (1) and Equation (2):

$$R_{FB1}(\text{k}\Omega) = \frac{1200 \cdot (V_{OUT} - 1)}{3.3 - V_{OUT}}, \quad V_{OUT} < 3.3V \quad (1)$$

$$R_{FB2}(\text{k}\Omega) = \frac{1200}{V_{OUT} - 3.3}, \quad V_{OUT} > 3.3V \quad (2)$$

The calculated resistance may need fine-tuning during the bench test. For typical applications, Table 1 provides the R_{FB} values for different output voltages.

Table 1: R_{FB} Values to Typical V_{OUT}

V_{OUT} (V)	R_{FB1} (k Ω)	R_{FB2} (k Ω)
1.0	0	NS
1.2	110	NS
1.5	324	NS
1.8	634	NS
2.5	2200	NS
3.3	NS	NS
5	NS	698

Under Voltage Lockout Point Setting

The MPM3570E has a 4.2V built-in UVLO rising threshold with a 450mV hysteresis. An external resistor between EN and GND can be used to get a higher equivalent UVLO threshold (see Figure 3).

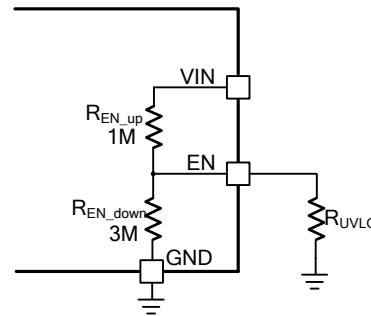

Figure 3: Adjustable UVLO using EN Pin

The resistor for adjusting the UVLO can be calculated with Equation (3):

$$R_{UVLO}(\text{k}\Omega) = \frac{1600}{V_{IN} - 2.13} \quad (3)$$

The calculated resistance may need fine-tuning during the bench test.

Input Capacitor

The MPM3570E integrates 3x0.1 μ F high frequency decoupling input ceramic capacitors to reduce switching spikes. A minimum input capacitance of 4.7 μ F is required adjacent to the V_{IN} pin for common application. To minimize the input ripple voltage, more external capacitors may be needed.

Ceramic capacitors with low ESR are recommended for best performance. The capacitance can vary significantly with temperature. Use capacitors with X5R and X7R ceramic dielectrics because they are fairly stable over a wide temperature range. Other types, including Y5V and Z5U, must not be used as they lose too much capacitance with frequency, temperature, and bias voltage.

To achieve a smaller solution size, choose a proper package size capacitor with a rating voltage compliant to the input spec. Table 2 contains a list of recommended input capacitors.

Table 2: Recommended Input Capacitors

Value	Description	Vendor	Part Number
4.7μF	100V,X7S,1210	Murata	GRM32DC72A475KE01
4.7μF	100V,X7S,1210	TDK	C3225X7S2A475K200AB
10μF	50V,X7R,1210	Murata	GRM32ER71H106KA12
10μF	50V,X7R,1210	TDK	C3225X7R1H106M250AC
10μF	25V,X7S,0805	Murata	GRM21BC71E106KE11
10μF	25V,X5R,0603	TDK	C1608X5R1E106M080AC

The capacitors must also have a ripple current rating that exceeds the converter's maximum input ripple current. Estimate the input ripple current with Equation (4):

$$I_{CIN} = I_{OUT} \times \sqrt{\frac{V_{OUT}}{V_{IN}} \times \left(1 - \frac{V_{OUT}}{V_{IN}}\right)} \quad (4)$$

The worst-case condition occurs at $V_{IN} = 2V_{OUT}$, where:

$$I_{CIN} = \frac{I_{OUT}}{2} \quad (5)$$

For simplification, choose an input capacitor with an RMS current rating that exceeds half the maximum load current.

The input capacitance value determines the converter input voltage ripple. If there is an input voltage ripple requirement, choose an external capacitor that meets the specification.

Estimate the input voltage ripple with Equation (6):

$$\Delta V_{IN} = \frac{I_{OUT}}{F_{SW} \times C_{IN}} \times \frac{V_{OUT}}{V_{IN}} \times \left(1 - \frac{V_{OUT}}{V_{IN}}\right) \quad (6)$$

The worst-case condition occurs at $V_{IN} = 2V_{OUT}$, where:

$$\Delta V_{IN} = \frac{1}{4} \times \frac{I_{OUT}}{F_{SW} \times C_{IN}} \quad (7)$$

Output Capacitor

The MPM3570E has an integrated 22μF output ceramic capacitor for stable operation. To reduce the output ripple and improve load transient response, add external capacitors as close as possible to the load. Ceramic capacitors with low ESR are recommended for best performance.

The capacitance can vary significantly with temperature. Use capacitors with X5R and X7R ceramic dielectrics, because they are fairly stable over a wide temperature range. Other types, including Y5V and Z5U, must not be used as they lose too much capacitance with frequency, temperature, and bias voltage. Initial values of 10μF to 47μF may be tried (either single or multiple capacitors in parallel). Table 3 contains a list of recommended output capacitors.

Table 3: Recommended Output Capacitors

Value	Description	Vendor	Part Number
10μF	10V,X7R,0805	Murata	GRM21BR71A106KE51
10μF	10V,X7R,0805	TDK	C2012X7R1A106K125AC
22μF	10V,X7T,0805	Murata	GRM21BD71A226ME44
22μF	10V,X7S,0805	TDK	C2012X7S1A226M125AC
47μF	10V,X5R,0805	Murata	GRM21BR61A476ME15
47μF	10V,X5R,0805	TDK	C2012X5R1A476M125AC

The output voltage ripple can be estimated with Equation (8):

$$\Delta V_{OUT} = \frac{V_{OUT}}{f_{SW} \times L} \times \left(1 - \frac{V_{OUT}}{V_{IN}}\right) \times \left(R_{ESR} + \frac{1}{8 \times f_{SW} \times C_{OUT}}\right) \quad (8)$$

When using ceramic capacitors, the capacitance dominates the impedance at the switching frequency. The capacitance also dominates the output voltage ripple. For simplification, estimate the output voltage ripple with Equation (9):

$$\Delta V_{OUT} = \frac{V_{OUT}}{8 \times f_{SW}^2 \times L \times C_{OUT}} \times \left(1 - \frac{V_{OUT}}{V_{IN}}\right) \quad (9)$$

EMI Considerations

High radiated EMI noise is a disadvantage for switching regulators. Fast switching turn-on and turn-off create the large di/dt change in the converters, which acts as the radiation sources in most systems. The MPM3570E is designed with an input EMI filter and other features to make its radiated emissions compliant with several EMC specifications, including CISPR22 Class B. The MPM3570E can meet CISPR25 Class 5 by adding only a small external input filter. For example, a PI model filter consisting of a 10μF capacitor, 2.2μH inductor, and 22μF capacitor is sufficient. Also, conducted emissions specifications, including CISPR22 Class B and CISPR25 class 5, can be met with this filter (see Figure 4).

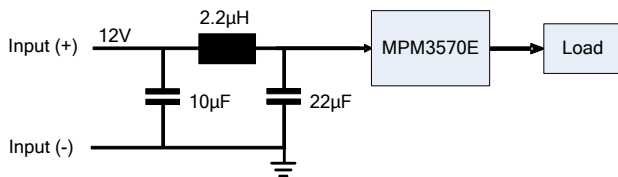
Figure 4: MPM3570E with EMI filter

The filter inductor needs to be placed at a certain distance to the module’s main inductor to avoid magnetic coupling. As the rating current is not large, a multi-layer inductor with a small package is preferred. Table 4 contains a list of recommended filter inductors.

Table 4: Recommended Filter Inductors

Value	Description	Vendor	Part Number
2.2µH	0.75A,300mΩ,0603	Murata	LQM18PN2R2MFRL
2.2µH	0.65A,300mΩ,0603	Taiyo Yuden	CKP1608D2R2M-T

Input Fusing

Certain applications may require fuses at the inputs of the power module. Fuses should also be used when there is the possibility of sustained input voltage reversal, which is not current-limited. For safety, we recommend a fast blow fuse installed in the ungrounded input supply line.

Thermal Considerations

The MPM3570E’s ability to accommodate a wide range of ambient temperatures is the result of its extremely high power conversion efficiency and resulting low power dissipation. However, the output current may need to be derated if it is required to operate in a high ambient temperature or deliver a large amount of continuous power. The amount of current derating is dependent upon the input voltage, output power, and ambient temperature. The air velocity (forced or natural convection) may also affect the thermal condition. The derating curves and temperature rise curves given in the Typical Performance Characteristics section can be used as a guide. These curves were generated by an MPM3570E mounted to a 40cm², 2-layer FR4 printed circuit board. Boards of other sizes and layer count can exhibit different thermal behavior, so it is incumbent upon the user to verify proper operation over the intended system’s line, load, and environmental operating conditions.

The thermal shutdown temperature of the MPM3570E is 175°C, so carefully consider the

layout of the circuit to ensure good heat sinking. The bulk of the heat flow out of the MPM3570E is through the bottom of the module and the pads into the printed circuit board. Consequently, a poor printed circuit board design can cause excessive heating, resulting in impaired performance or reliability. Please refer to the PCB layout section below for printed circuit board design suggestions.

PCB Layout Guidelines

Common PCB layout problems have been alleviated or even eliminated by the high level of integration of the MPM3570E. For optimal performance, refer to Figure 5 and Figure 6 and follow the guidelines below:

1. Use large copper areas for power planes (VIN, VOUT, and GND) to minimize conduction loss and thermal stress.
2. Use multiple vias to connect the power planes to the internal layers.
3. Place the vias away from pads and vias on the module board.
These vias can provide both a good connection and thermal path to the internal planes of the printed circuit board.
4. Place the ceramic input and output capacitors close to the module pins to minimize high frequency noise.
5. Keep the connections as short and wide as possible.
6. Place R_{FB} as close to FB as possible.

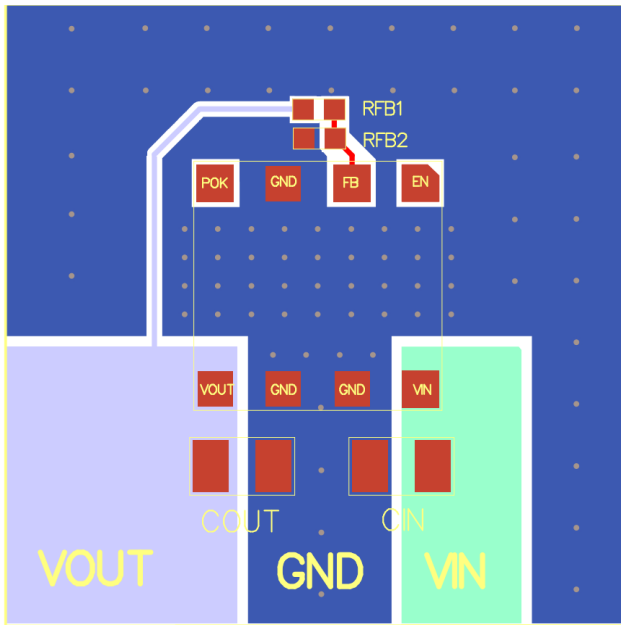

Figure 5: Top-Layer Recommended Layout

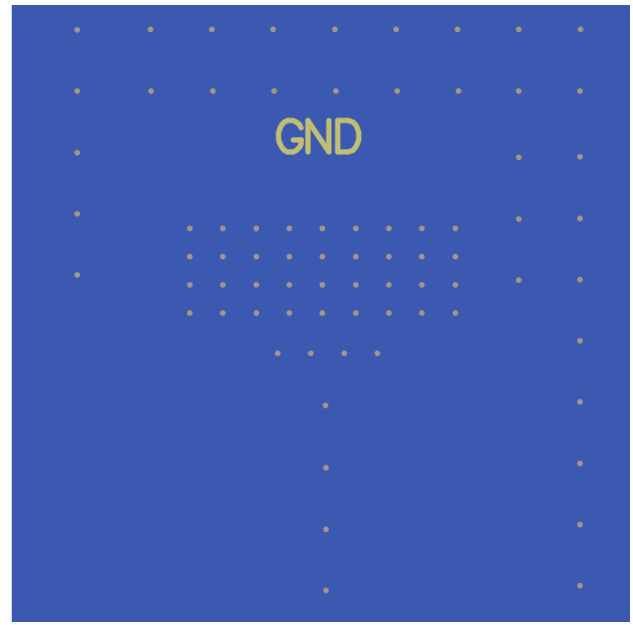

Figure 6: Bottom-Layer Recommended Layout

TYPICAL APPLICATION

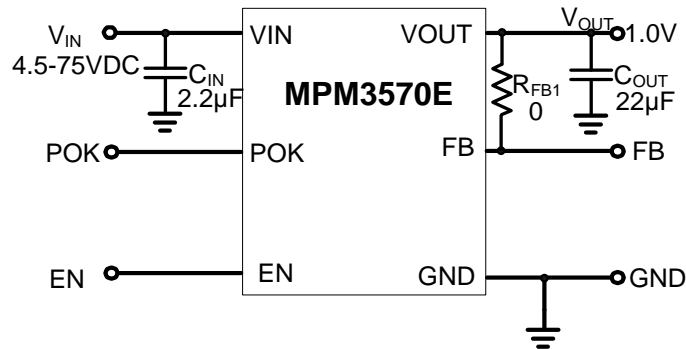

Figure 7: Typical Application Circuit with 1.0V Output

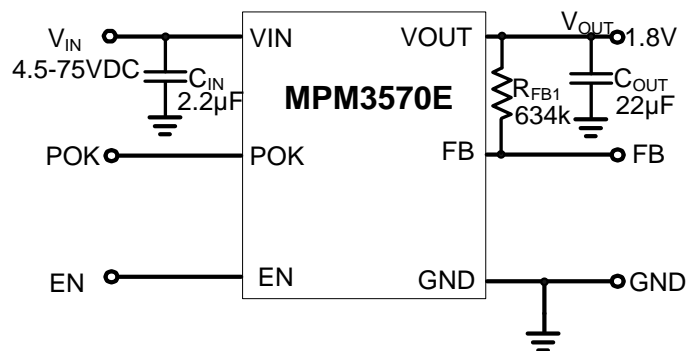

Figure 8: Typical Application Circuit with 1.8V Output

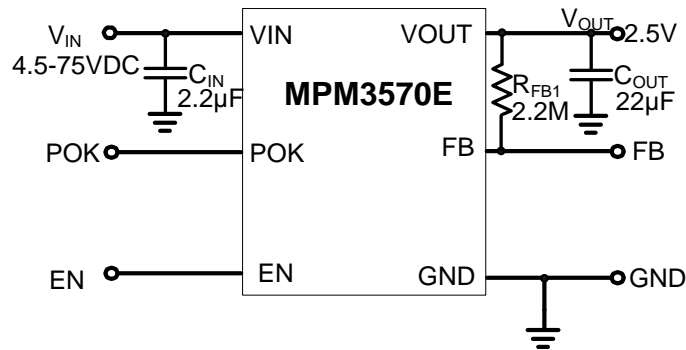

Figure 9: Typical Application Circuit with 2.5V Output

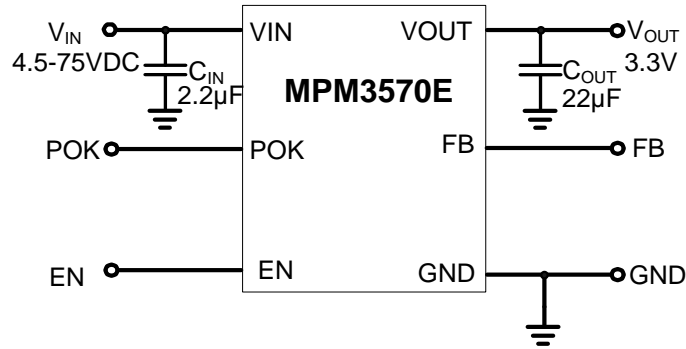

Figure 10: Typical Application Circuit with 3.3V Output

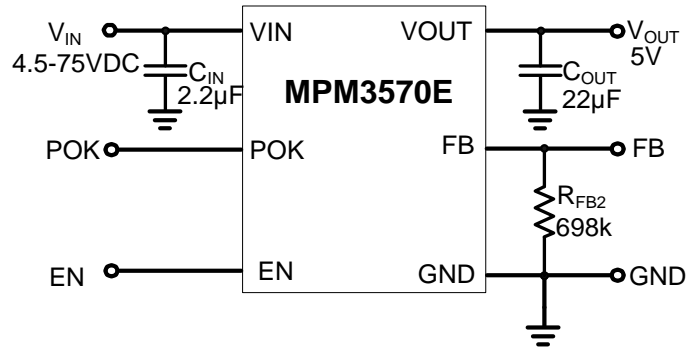

Figure 11: Typical Application Circuit with 5V Output

X-ON Electronics

Largest Supplier of Electrical and Electronic Components

Click to view similar products for [Switching Voltage Regulators](#) category:

Click to view products by [Monolithic Power Systems](#) manufacturer:

Other Similar products are found below :

[FAN53610AUC33X](#) [FAN53611AUC123X](#) [FAN48610BUC33X](#) [FAN48610BUC45X](#) [FAN48617UC50X](#) [R3](#) [430464BB](#) [KE177614](#)
[MAX809TTR](#) [NCV891234MW50R2G](#) [NCP81103MNTXG](#) [NCP81203PMNTXG](#) [NCP81208MNTXG](#) [NCP81109GMNTXG](#)
[SCY1751FCCT1G](#) [NCP81109JMNTXG](#) [AP3409ADNTR-G1](#) [NCP81241MNTXG](#) [LTM8064IY](#) [LT8315EFE#TRPBF](#) [NCV1077CSTBT3G](#)
[XCL207A123CR-G](#) [MPM54304GMN-0002](#) [MPM54304GMN-0003](#) [XDPE132G5CG000XUMA1](#) [DA9121-B0V76](#) [MP8757GL-P](#)
[MIC23356YFT-TR](#) [LD8116CGL](#) [HG2269M/TR](#) [OB2269](#) [XD3526](#) [U6215A](#) [U6215B](#) [U6620S](#) [LTC3803ES6#TR](#) [LTC3803ES6#TRM](#)
[LTC3412IFE](#) [LT1425IS](#) [MAX25203BATJA/VY+](#) [MAX77874CEWM+](#) [XC9236D08CER-G](#) [ISL95338IRTZ](#) [MP3416GJ-P](#) [BD9S201NUX-CE2](#) [MP5461GC-Z](#) [MPQ4415AGQB-Z](#) [MPQ4590GS-Z](#) [MCP1603-330IMC](#) [MCP1642B-18IMC](#)