

DESCRIPTION

The MPQ4462 is a high-frequency, step-down, switching regulator with an integrated, high-side, high-voltage, power MOSFET. It provides a 3.5A output with current-mode control for fast loop response and easy compensation.

The wide 3.8V-to-36V input range accommodates a variety of step-down applications, including those in an automotive input environment. A 120µA operational quiescent current allows for battery-powered applications.

Switching-frequency scaling allows for high power-conversion efficiency over a wide load range by scaling down the switching frequency at light loads to reduce the switching and gate driving losses.

The frequency foldback prevent inductor-current runaway during startup, and thermal shutdown provides reliable and fault tolerant operation.

The MPQ4462 can operate at up to 4MHz for EMI-sensitive applications, such as AM radio and ADSL applications.

The MPQ4462 is available in both 3mm×3mm QFN10 and SOIC8E packages.

FEATURES

- 120µA Quiescent Current
- Wide 3.8V-to-36V Input Range
- 150mΩ Internal Power MOSFET
- Up to 4MHz Programmable Switching Frequency
- Stable with a Ceramic Capacitor
- Internal Soft-Start
- Internally-Set Current Limit without a Current Sensing Resistor
- Output Adjustable from 0.8V to 30V
- Available in 3mm×3mm QFN10 and SOIC8E Packages.
- Available in AEC-Q100 Qualified Grade 1

APPLICATIONS

- High-Voltage Power Conversion
- Automotive Systems
- Industrial Power Systems
- Distributed Power Systems
- Battery Powered Systems

All MPS parts are lead-free and adhere to the RoHS directive. For MPS green status, please visit MPS website under Products, Quality Assurance page. "MPS" and "The Future of Analog IC Technology" are registered trademarks of Monolithic Power Systems, Inc.

TYPICAL APPLICATION

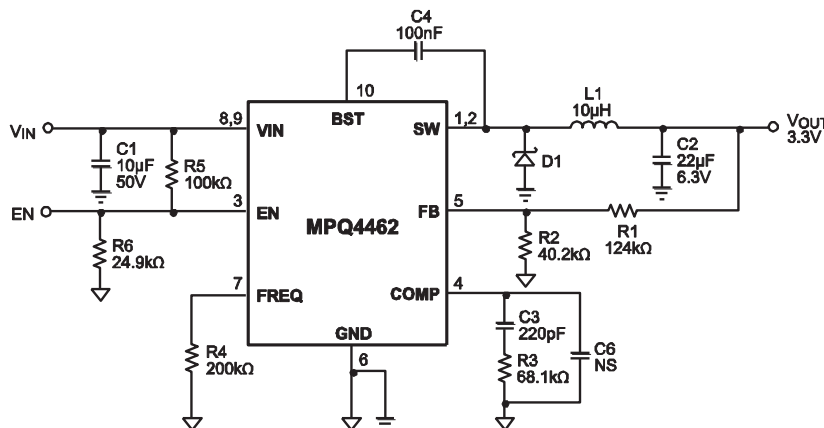

Efficiency vs. Load Current
V_{OUT}=3.3V

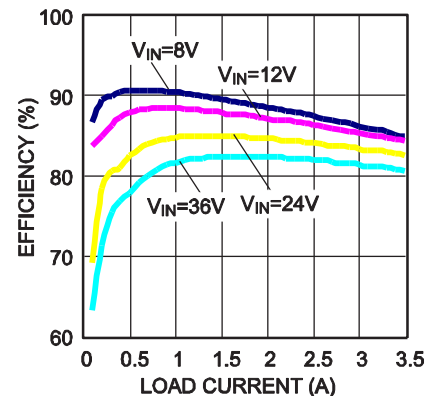

ORDERING INFORMATION

Part Number	Package	Top Marking
MPQ4462DQ*	QFN10 (3mm×3mm)	Z2
MPQ4462DN**	SOIC8E	MP4462DN
MPQ4462DQ-AEC1*	QFN10 (3mm×3mm)	Z2
MPQ4462DN-AEC1**	SOIC8E	MP4462DN

*For Tape & Reel, add suffix –Z (e.g. MPQ4462DQ–AEC1-Z);
For RoHS, compliant packaging, add suffix –LF (e.g. MPQ4462DQ–AEC1-LF-Z).

**For Tape & Reel, add suffix –Z (e.g. MPQ4462DN–AEC1-Z);
For RoHS, compliant packaging, add suffix –LF (e.g. MPQ4462DN–AEC1-LF-Z).

PACKAGE REFERENCE

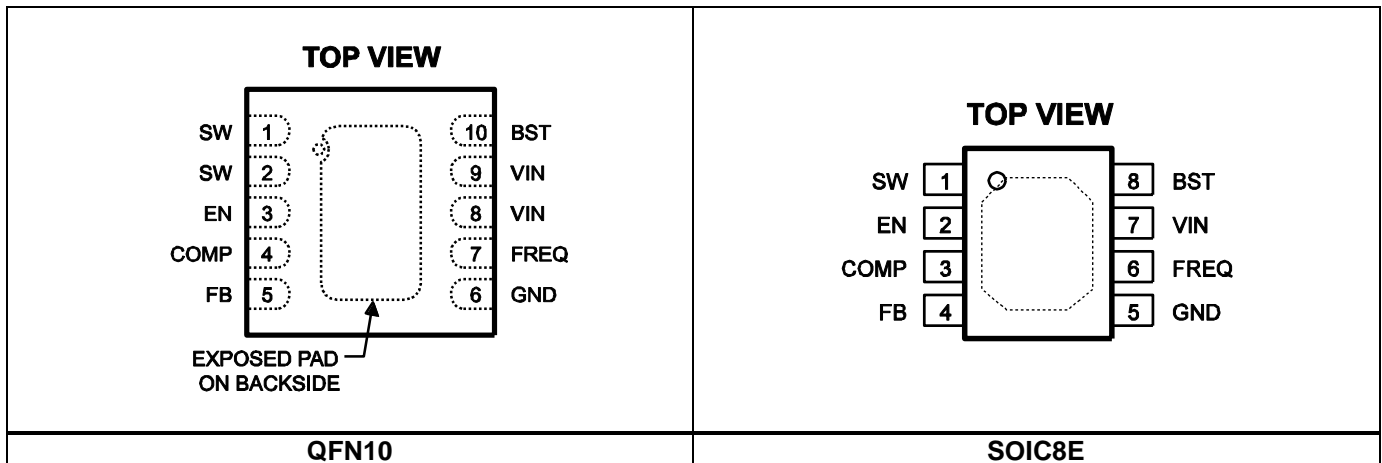

ABSOLUTE MAXIMUM RATINGS ⁽¹⁾

Supply Voltage (V_{IN}).....	–0.3V to +40V
Switch Voltage (V_{SW}).....	–0.3V to $V_{IN} + 0.3V$
BST to SW.....	–0.3V to +6V
All Other Pins.....	–0.3V to +6V
Continuous Power Dissipation ($T_A = +25^\circ C$) ⁽²⁾	
QFN10 (3mm×3mm).....	2.5W
SOIC8E.....	2.5W
Junction Temperature.....	150°C
Lead Temperature.....	260°C
Storage Temperature.....	–65°C to +150°C

Recommended Operating Conditions ⁽³⁾

Supply Voltage V_{IN}	3.8V to 36V
Output Voltage V_{OUT}	0.8V to 30V
Operating Junct. Temp.	–40°C to +125°C

<i>Thermal Resistance</i> ⁽⁴⁾	θ_{JA}	θ_{JC}
QFN10 (3mm×3mm)	50	12 ... °C/W
SOIC8E.....	50	10 ... °C/W

Notes:

- 1) Exceeding these ratings may damage the device.
- 2) The maximum allowable power dissipation is a function of the maximum junction temperature T_J (MAX), the junction-to-ambient thermal resistance θ_{JA} , and the ambient temperature T_A . The maximum allowable continuous power dissipation at any ambient temperature is calculated by P_D (MAX) = $(T_J$ (MAX)– T_A)/ θ_{JA} . Exceeding the maximum allowable power dissipation will cause excessive die temperature, and the regulator will go into thermal shutdown. Internal thermal shutdown circuitry protects the device from permanent damage.
- 3) The device is not guaranteed to function outside of its operating conditions.
- 4) Measured on JESD51-7, 4-layer PCB.

ELECTRICAL CHARACTERISTICS

$V_{IN} = 12V$, $V_{EN} = 2.5V$, $V_{COMP} = 1.4V$, $T_J = -40^{\circ}C$ to $+125^{\circ}C$, unless otherwise noted. Typical values are at $T_J = 25^{\circ}C$.

Parameter	Symbol	Condition	Min	Typ	Max	Units
Feedback Voltage	V_{FB}	$V_{IN} = 4.5V$ to $36V$, $T_J = 25^{\circ}C$	0.786	0.792	0.803	V
		$V_{IN} = 4.5V$ to $36V$	0.773		0.812	
Upper Switch On Resistance ⁽⁵⁾	$R_{DS(ON)}$	$V_{BST} - V_{SW} = 5V$		150		m Ω
Upper Switch Leakage		$V_{EN} = 0V$, $V_{SW} = 0V$, $V_{IN} = 36V$		0.01	1	μA
Current Limit		Duty Cycle = 50%	4.0	5.5		A
COMP to Current Sense Transconductance ⁽⁵⁾	G_{CS}			9		A/V
Error Amp Voltage Gain ⁽⁶⁾				200		V/V
Error Amp Transconductance		$I_{COMP} = \pm 3\mu A$	35	60	95	$\mu A/V$
Error Amp Min Source Current		$V_{FB} = 0.7V$		5		μA
Error Amp Min Sink Current		$V_{FB} = 0.9V$		-5		μA
VIN UVLO Threshold			2.6	3.0	3.4	V
VIN UVLO Hysteresis				400		mV
Soft-Start Time ⁽⁵⁾		$V_{FB} = 0V$ to $0.8V$		1.5		ms
Oscillator Frequency		$R_{FREQ} = 45.3k\Omega$	1.6	2	2.4	MHz
Shutdown Supply Current		$V_{EN} = 0V$		11	18	μA
Quiescent Supply Current		No load, $V_{FB} = 0.9V$		120	160	μA
Thermal Shutdown ⁽⁵⁾				150		$^{\circ}C$
Thermal Shutdown Hysteresis ⁽⁵⁾				15		$^{\circ}C$
Minimum OFF Time ⁽⁵⁾				100		ns
Minimum ON Time ⁽⁵⁾				80		ns
EN Rising Threshold			1.4	1.5	1.7	V
EN Falling Threshold			1.1	1.2	1.4	V
EN Threshold Hysteresis				300		mV

Note:

5) Derived from bench characterization. Not tested in production.

6) Guaranteed by design. Not tested in production.

PIN FUNCTIONS

QFN Pin #	SOIC8E Pin #	Name	Description
1, 2	1	SW	Switch Node. Output of the high-side switch. Requires a low-forward-drop Schottky diode to ground. Place the diode close to the SW pins to reduce switching spikes.
3	2	EN	Enable. Pull below the specified threshold to shut the chip down. Pull it up above the specified threshold or leave it floating to enable the chip.
4	3	COMP	Compensation. Output of the error amplifier. Includes control-loop frequency compensation.
5	4	FB	Feedback. Input to the error amplifier. The tap of a resistor divider between the output and GND sets the output voltage to the internal +0.8V reference.
6	5	GND	Ground.
7	6	FREQ	Switching Frequency Set. Connect a resistor from this pin to ground to set the switching frequency.
8, 9	7	VIN	Input Supply. Supplies power to all internal control circuitry. Requires a decoupling capacitor to ground to minimize switching spikes.
10	8	BST	Bootstrap. Positive power supply to the internal, floating, high-side MOSFET driver. Connect a bypass capacitor between this pin and SW.
		Exposed Pad	Ground Pad. Connect to GND plane for optimal thermal performance.

TYPICAL CHARACTERISTICS

Feedback Voltage vs. Junction Temperature

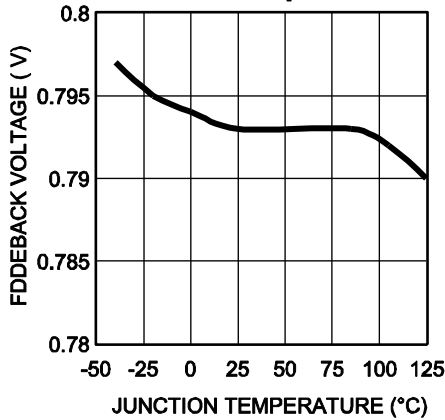

Quiescent Current vs. Junction Temperature

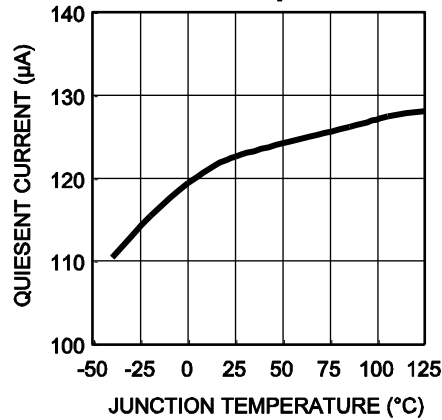

Shutdown Current vs. Junction Temperature

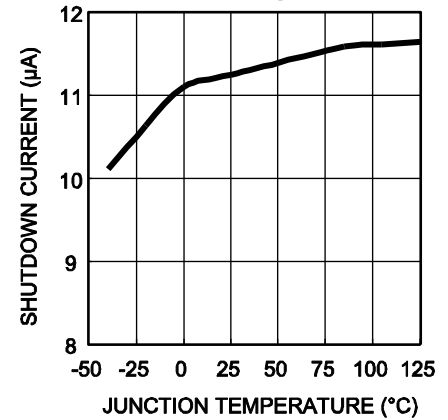

V_{IN} UVLO vs. Junction Temperature

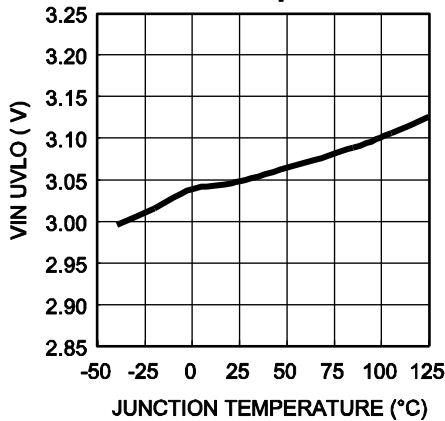

EN Rising Threshold vs. Junction Temperature

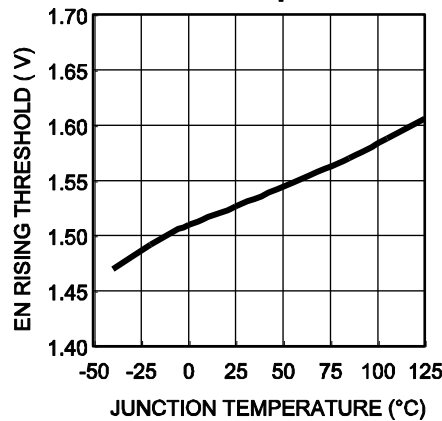

EN Falling Threshold vs. Junction Temperature

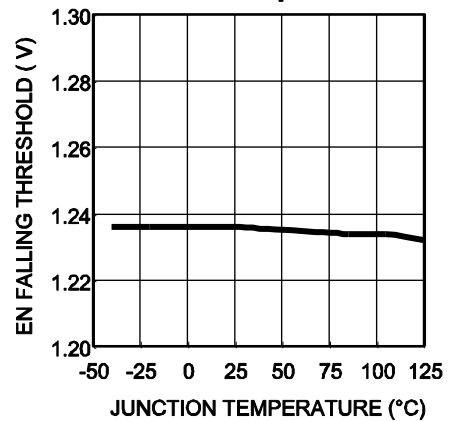

I_{PEAK} vs. Duty

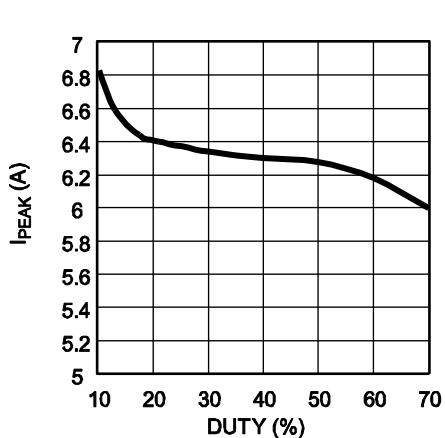

I_{PEAK} vs. Junction Temperature

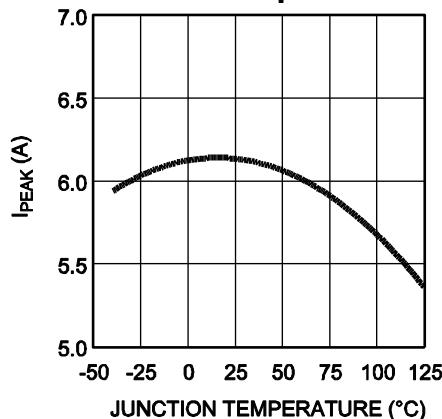

R_{DS(ON)} vs. Junction Temperature

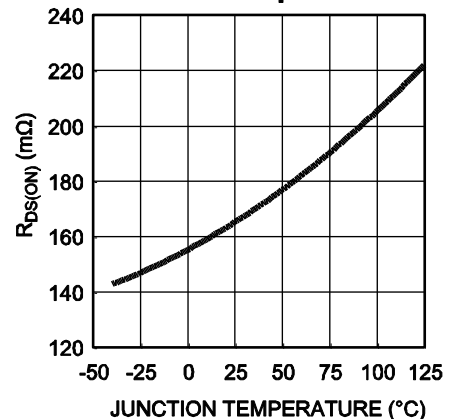

TYPICAL CHARACTERISTICS *(continued)*

**Oscillating Frequency
vs. R_{FREQ}**

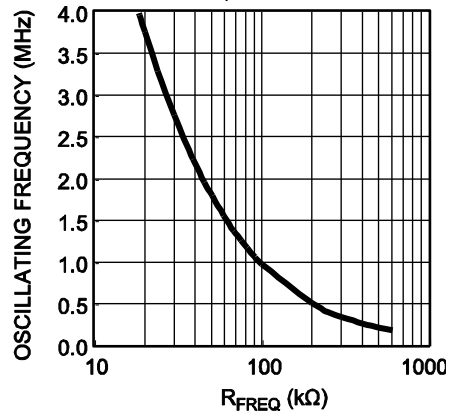

TYPICAL PERFORMANCE CHARACTERISTICS

$V_{IN} = 12V$, $V_{OUT} = 3.3V$, $C1 = 10\mu F$, $C2 = 22\mu F$, $L = 10\mu H$ and $T_A = +25^\circ C$, unless otherwise noted.

Efficiency vs. Load Current

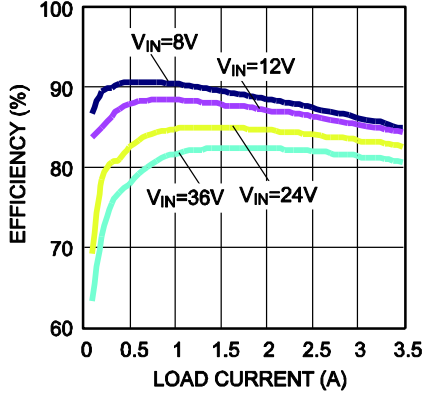

Load Regulation

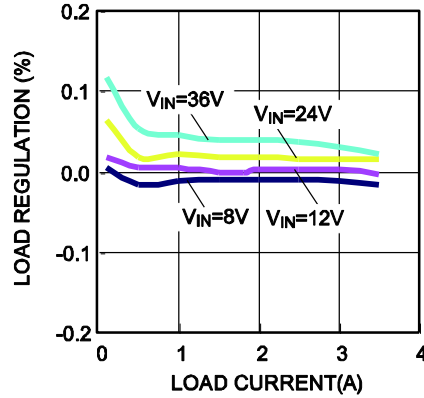

Line Regulation

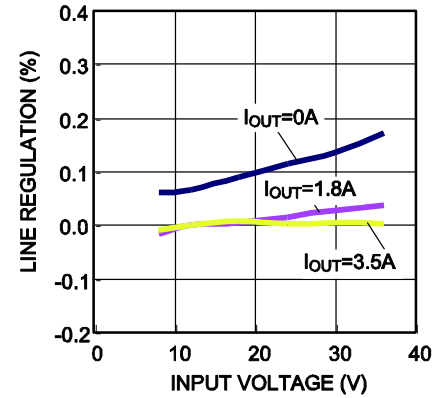

Load Transient

$I_{OUT} = 2.5A$ to $3.5A$, $30mA/\mu s$

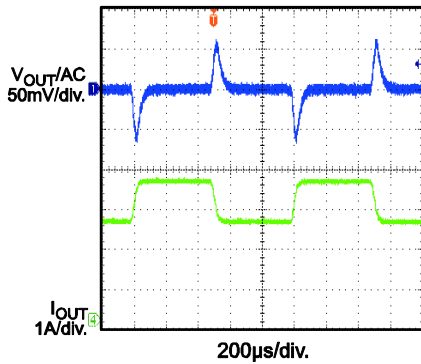

Output Ripple

$I_{OUT} = 0A$

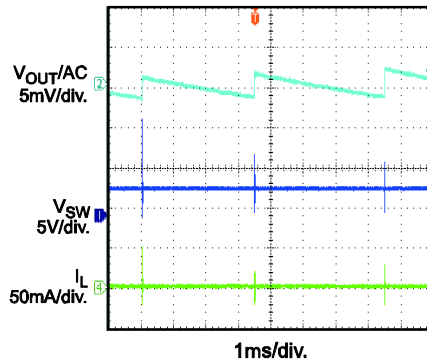

Output Ripple

$I_{OUT} = 3.5A$

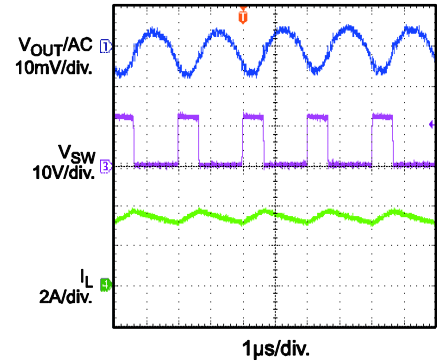

Startup Through V_{IN}

$I_{OUT} = 3.5A$

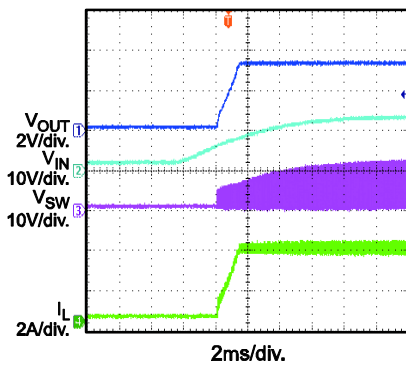

Shutdown Through V_{IN}

$I_{OUT} = 3.5A$

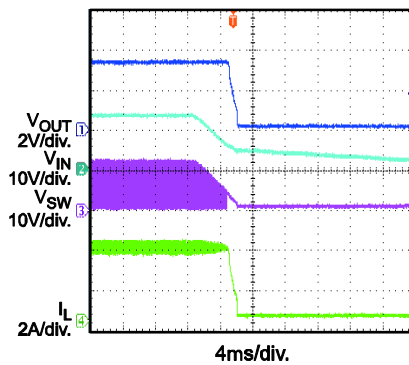

Startup Through EN

$I_{OUT} = 3.5A$

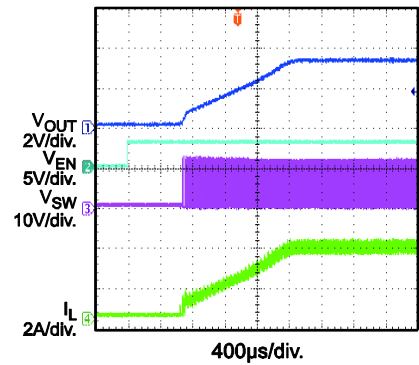

TYPICAL PERFORMANCE CHARACTERISTICS *(continued)*

$V_{IN} = 12V$, $V_{OUT} = 3.3V$, $C1 = 10\mu F$, $C2 = 22\mu F$, $L = 10\mu H$ and $T_A = +25^\circ C$, unless otherwise noted.

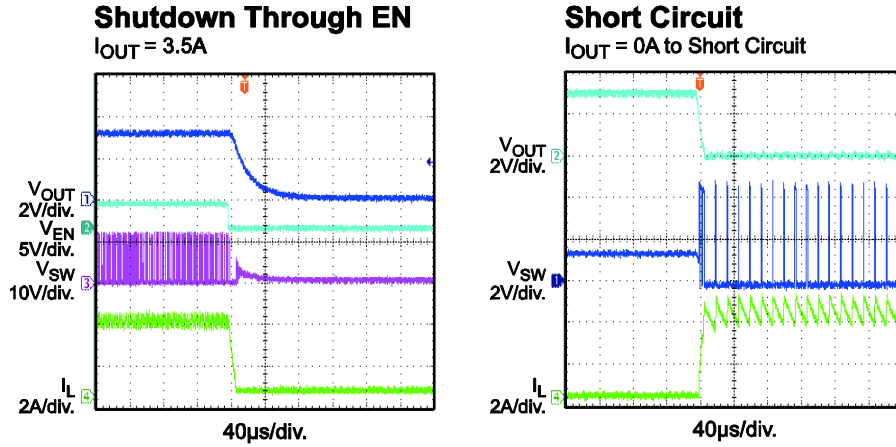

BLOCK DIAGRAM

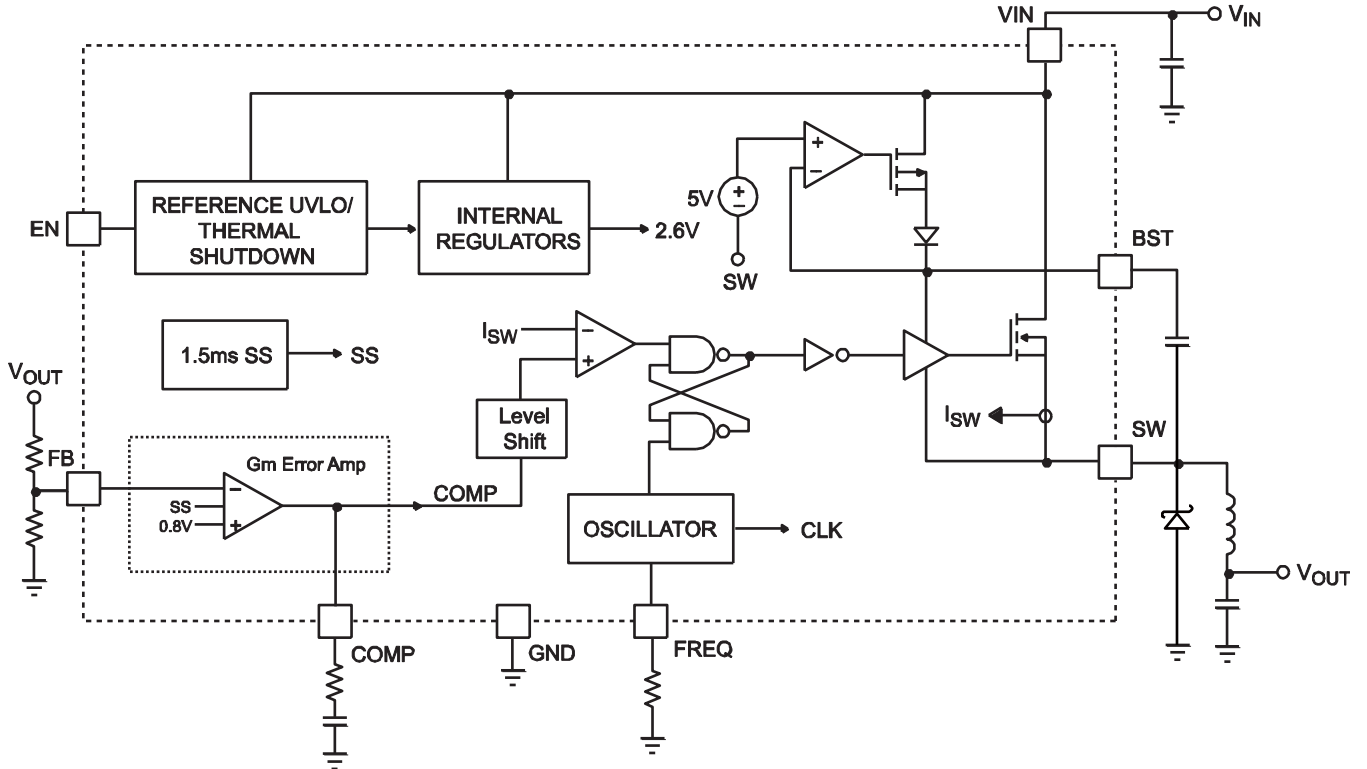

Figure 1: Functional Block Diagram

OPERATION

The MPQ4462 is a variable-frequency, asynchronous, step-down switching regulator with an integrated, high-side, high-voltage, power MOSFET. It provides a highly efficient output with current mode control for fast loop response and easy compensation. It features a wide input-voltage range, internal soft-start control, and precise current limiting. Its very-low operational quiescent current makes it suitable for battery-powered applications.

PWM Control

At moderate-to-high output current, the MPQ4462 operates in a fixed-frequency, peak-current-control mode to regulate the output voltage. The internal clock initiates a PWM cycle that turns the power MOSFET on. This MOSFET remains on until its current reaches the value set by V_{COMP} . When the power MOSFET is off, it remains off for at least 100ns before the next cycle starts. If the current in the power MOSFET does not reach the COMP set current value within one PWM period, the power MOSFET remains on to save a turn-off operation.

Error Amplifier

The error amplifier compares V_{FB} to the internal reference (V_{REF}) and outputs a current proportional to the difference between the two. This output current charges the external compensation network to form V_{COMP} , which controls the power MOSFET current.

While operating, the V_{COMP} minimum is clamped to 0.9V and its maximum is clamped to 2.0V. COMP is internally pulled down to GND in shutdown mode. COMP should not be pulled up beyond 2.6V.

Internal Regulator

The 2.6V internal regulator powers most of the internal circuits. This regulator takes V_{IN} and operates in the full V_{IN} range. When V_{IN} exceeds 3.0V, the output of the regulator is in full regulation. When V_{IN} falls below 3.0V, the output decreases.

Enable Control

The MPQ4462 has a dedicated enable-control pin (EN). Enable uses logic-high to enable and

disable the chip. Its falling threshold is precisely 1.2V, and its rising threshold is 1.5V (300mV higher).

When floating, EN is pulled up to about 3.0V by an internal 1 μ A current source to remain enabled. To pull-down requires a 1 μ A current.

When V_{EN} is pulled down below 1.2V, the chip enters its lowest shutdown current mode. When V_{EN} exceeds 0V but remains below its rising threshold, the chip remains in shutdown mode but the shutdown current increases slightly.

Under-Voltage Lockout (UVLO)

Under-voltage lockout (UVLO) protects the chip from operating at insufficient supply voltages. The UVLO rising threshold is about 3.0V while its falling threshold is a consistent 2.6V.

Internal Soft-Start

The soft-start prevents the converter output voltage from overshooting during startup. When the chip starts, the internal circuitry generates a soft-start voltage (V_{SS}) that ramps up from 0V to 2.6V. When $V_{SS} < V_{REF}$, V_{SS} becomes the reference. When $V_{SS} > V_{REF}$, V_{REF} resumes as the reference.

Thermal Shutdown

Thermal shutdown prevents the chip from operating at exceedingly high temperatures. When the die temperature exceeds its upper threshold, the chip shuts down. When the temperature falls below its lower threshold, chip function resumes.

Floating Driver and Bootstrap Charging

An external bootstrap capacitor powers the floating power MOSFET driver. This floating driver has its own UVLO protection, with a UVLO rising threshold of 2.2V with a falling threshold of 150mV.

A dedicated, internal, bootstrap regulator charges and regulates the bootstrap capacitor ~5V. When the voltage between the BST and SW nodes falls below its regulation voltage, a PMOS pass transistor connected from V_{IN} to BST turns on. The current-charging path is $V_{IN} \rightarrow \text{BST} \rightarrow \text{SW}$. The external circuit should provide enough voltage headroom to facilitate charging.

If V_{IN} is sufficiently higher than V_{SW} , the bootstrap capacitor charges. When the power MOSFET is ON, $V_{IN} \approx V_{SW}$ so the bootstrap capacitor cannot charge. When the external diode is ON, the $V_{IN} - V_{SW}$ is at its maximum for optimal charging. When there is no current in the inductor, $V_{SW} = V_{OUT}$ so $V_{IN} - V_{OUT}$ charges the bootstrap capacitor.

At higher duty cycles, the bootstrap-charging period is shorter so the bootstrap capacitor may not charge sufficiently. If the internal circuit does not have sufficient voltage and the bootstrap capacitor is not charged, an external circuit can ensure the bootstrap voltage is in the normal operational region.

The floating driver's DC quiescent current $\sim 20\mu A$. Select a bleeding current at the SW node meets the following criterion:

$$I_O + \frac{V_O}{(R1 + R2)} > 20\mu A$$

Current Comparator and Current Limit

A current-sense MOSFET accurately senses the power-MOSFET current. The sense value is compared to V_{COMP} by a high-speed current comparator. When the power MOSFET turns on, the comparator is first blanked till the end of the turn-on transition. When the sensed current exceeds V_{COMP} , the comparator output is low, turning off the power MOSFET. The cycle-by-cycle maximum current of the internal power MOSFET is internally limited.

Startup and Shutdown

If both V_{IN} and V_{EN} exceed their respective thresholds, the chip starts. The reference block starts first, generating stable reference voltage and currents, and then the internal regulator is enabled. The regulator provides a stable supply for the remaining circuits.

While the internal supply rail is up, an internal timer holds the power MOSFET OFF for about $50\mu s$ to blank the startup noise. When the internal soft-start block is enabled, it first holds V_{SS} low before slowly ramping up.

Three events can shut down the chip: V_{EN} LOW, V_{IN} LOW, and thermal shutdown. For shutdown, the power MOSFET turn off to avoid

triggering any faults. V_{COMP} and the internal supply rail are then pulled down.

Programmable Oscillator

An external resistor (R_{FREQ}) from the FREQ pin to ground sets the MPQ4462 oscillating frequency.

APPLICATION INFORMATION

COMPONENT SELECTION

Frequency

The MPQ4462 has an externally-adjustable frequency using R_{FREQ} . See Table 1 for a list of recommended R_{FREQ} value for various f_s .

Table 1: f_s vs. R_{FREQ}

R_{FREQ} (k Ω)	f_s (MHz)
18	4
20	3.8
22.1	3.5
24	3.3
26.7	3
30	2.8
33.2	2.5
39	2.2
45.3	2
51	1.8
57.6	1.6
68	1.4
80.6	1.2
100	1
133	0.8
200	0.5
340	0.3
536	0.2

Output Voltage

Connecting FB to the tap of a resistor divider from V_{OUT} to ground sets V_{OUT} such that:

$$V_{OUT} = V_{FB} \frac{(R1 + R2)}{R2}$$

Without a load, the MPQ4462 outputs ~20 μ A from its high-side BST circuitry. Keep $R2 \leq 40k\Omega$ to absorb this small amount of current. Selecting $R2=40.2k\Omega$, $R1$ is then:

$$R1 = 50.25 \times (V_{OUT} - 0.8)(k\Omega)$$

For example, for $V_{OUT}=3.3V$ and $R2=40.2k\Omega$, then $R1$ is 127k Ω .

Inductor

The inductor supplies constant current to the output load while being driven by the switching input voltage. A larger inductor will reduce ripple current and lower output ripple voltage, but is physically larger, and have a higher series resistance and/or lower saturation current.

To choose a balanced inductor value, allow the peak-to-peak inductor ripple current approximately equal 30% of the maximum switching current limit. To ensure that the peak inductor current is below the maximum switch current limit estimate and inductor value as:

$$L1 = \frac{V_{OUT}}{f_s \times \Delta I_L} \times \left(1 - \frac{V_{OUT}}{V_{IN}} \right)$$

Where V_{OUT} is the output voltage, V_{IN} is the input voltage, f_s is the switching frequency, and ΔI_L is the peak-to-peak inductor-ripple current.

Choose an inductor that will not saturate under the maximum inductor peak current, which is:

$$I_{LP} = I_{LOAD} + \frac{V_{OUT}}{2 \times f_s \times L1} \times \left(1 - \frac{V_{OUT}}{V_{IN}} \right)$$

Where I_{LOAD} is the load current.

Output Rectifier Diode

The output rectifier diode supplies the current to the inductor when the high-side switch is off. To reduce losses due to the diode forward voltage and recovery times, use a Schottky diode.

Choose a diode whose maximum reverse voltage rating exceeds the maximum input voltage, and whose current rating exceeds the maximum load current.

Input Capacitor

The input current to the step-down converter is discontinuous and requires a capacitor to supply the AC current to the step-down converter while maintaining the DC input voltage. Use low-ESR capacitors for the best performance. Ceramic capacitors are best, but tantalum or low-ESR electrolytic capacitors may also suffice.

For simplicity, choose an input capacitor with an RMS current rating greater than half of the maximum load current.

The input capacitor (C1) can be electrolytic, tantalum, or ceramic. Electrolytic or tantalum capacitors will need a small, high-quality ceramic capacitor (0.1µF) placed as close to the IC as possible. Ceramic capacitors must have enough capacitance to prevent excessive input voltage ripple. The capacitor-incurred input voltage ripple is approximately:

$$\Delta V_{IN} = \frac{I_{LOAD}}{f_s \times C1} \times \frac{V_{OUT}}{V_{IN}} \times \left(1 - \frac{V_{OUT}}{V_{IN}}\right)$$

Output Capacitor

The output capacitor (C2) maintains the output DC voltage. Use ceramic, tantalum, or low-ESR electrolytic capacitors. Low-ESR capacitors are best at limiting the output voltage ripple. The output voltage ripple is approximately:

$$\Delta V_{OUT} = \frac{V_{OUT}}{f_s \times L} \times \left(1 - \frac{V_{OUT}}{V_{IN}}\right) \times \left(R_{ESR} + \frac{1}{8 \times f_s \times C2}\right)$$

Where L is the inductor and R_{ESR} is the output capacitor's equivalent series resistance.

If using ceramic capacitors, the capacitance dominates the impedance at the switching frequency and contributes to the majority of the output voltage ripple. The output voltage ripple is approximately:

$$\Delta V_{OUT} = \frac{V_{OUT}}{8 \times f_s^2 \times L \times C2} \times \left(1 - \frac{V_{OUT}}{V_{IN}}\right)$$

If using either tantalum or electrolytic capacitors, the ESR dominates the impedance at the switching frequency. The output ripple is approximately:

$$\Delta V_{OUT} = \frac{V_{OUT}}{f_s \times L} \times \left(1 - \frac{V_{OUT}}{V_{IN}}\right) \times R_{ESR}$$

The output capacitor also affects the regulatory-system's stability. The MPQ4462 can be optimized for a wide range of capacitances and ESR values.

Compensation Components

The MPQ4462 employs current-mode control for easy compensation and fast transient response. The COMP pin—the output of the internal error amplifier—controls system stability and transient response. A series RC combination adds a pole-zero pair to the control system. The DC gain of the voltage feedback loop is:

$$A_{VDC} = R_{LOAD} \times G_{CS} \times A_{VEA} \times \frac{V_{FB}}{V_{OUT}}$$

Where

A_{VEA} is the error amplifier voltage gain (200V/V)

G_{CS} is the current sense transconductance (9A/V), and

R_{LOAD} is the load resistor value.

The system has two important poles: the compensation capacitor (C3) and the error amplifier's output resistor; and the output capacitor and the load resistor. These poles are located at:

$$f_{P1} = \frac{G_{EA}}{2\pi \times C3 \times A_{VEA}}$$

$$f_{P2} = \frac{1}{2\pi \times C2 \times R_{LOAD}}$$

Where, G_{EA} is the error amplifier's transconductance, 60µA/V.

The system has one important zero due to the compensation capacitor (C3) and the compensation resistor (R3). This zero is located at:

$$f_{Z1} = \frac{1}{2\pi \times C3 \times R3}$$

The system may have another important zero if the output capacitor is large and/or has a high-ESR. The zero is located at:

$$f_{ESR} = \frac{1}{2\pi \times C2 \times R_{ESR}}$$

In case requires a third pole set by the compensation capacitor (C6) and the

compensation resistor (R3). This pole is located at:

$$f_{P3} = \frac{1}{2\pi \times C6 \times R3}$$

The compensator shapes the converter transfer function for a desired loop gain. The feedback loop's unity-gain crossover frequency is important. Lower crossover frequencies result in slow line and load transient responses, while higher crossover frequencies increase system instability. For most applications, set the crossover frequency to $\sim 0.1 \times f_s$. Table 2 lists some typical compensation-component values for standard output voltages. The component values are optimized for fast transient responses and good stability at given conditions.

Table 2: Compensation Values for Typical Output Voltage/Capacitor Combinations

V _{OUT} (V)	L (μH)	C2 (μF)	R3 (kΩ)	C3 (pF)	C6
1.8	4.7	47	105	100	None
2.5	4.7 - 6.8	22	54.9	220	None
3.3	6.8 - 10	22	68.1	220	None
5	15 - 22	22	100	150	None
12	22 - 33	22	147	150	None

To optimize the compensation components for conditions not listed in Table 2:

1. Choose R3 for the desired crossover frequency:

$$R3 = \frac{2\pi \times C2 \times f_c}{G_{EA} \times G_{CS}} \times \frac{V_{OUT}}{V_{FB}}$$

Where f_c is the desired crossover frequency.

2. Choose C3 for the desired phase margin. For applications with typical inductor values, setting the compensation zero (f_{z1}) below $0.25 \times f_c$ provides sufficient phase margin. C3 must meet the following criterion:

$$C3 > \frac{4}{2\pi \times R3 \times f_c}$$

3. Determine if C6 is required. Add C6 if the ESR zero of the output capacitor is located at $< 0.5 \times f_c$, or if the following relationship is true:

$$\frac{1}{2\pi \times C2 \times R_{ESR}} < \frac{f_s}{2}$$

Select C6 to set the pole (f_{P3}) at the the ESR zero. Determine the C6 as:

$$C6 = \frac{C2 \times R_{ESR}}{R3}$$

High-Frequency Operation

Set the MP4462's switching frequency up to 4MHz through an external resistor. For switching frequencies above 2MHz, take the following into consideration:

- The minimum ON-time is ~ 80 ns. Pulse skipping occurs more often at higher switching frequencies due to the minimum ON-time.
- The recommended operating voltage is < 12 V, and < 24 V at 2MHz. Refer to Figure 2 for more information.

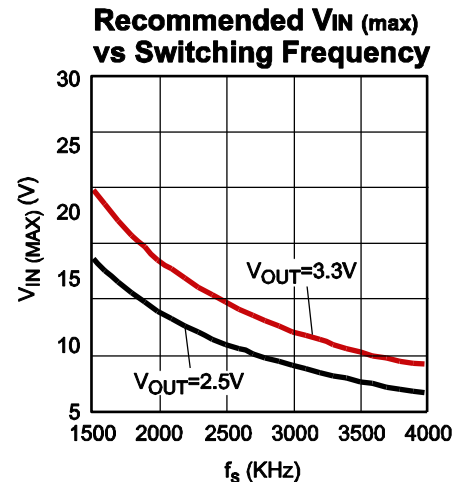

Figure 2: Recommended Max. V_{IN} vs f_s

- The internal bootstrap circuit's impedance may limit the charge to the bootstrap capacitor during each $(1-D) \times T_S$ charging period. Add an external bootstrap charging diode if the switching frequency is above 2MHz.
- At higher switching frequencies, the capacitor's inductive reactance (X_L) dominates, so that the ESL of the input/output capacitor determines the input/output ripple voltage at higher switching frequencies. Select a high-frequency ceramic capacitor as the input decoupling capacitor and the output filtering capacitor for high-frequency operation.
- Layout becomes more important when the device switches at higher frequencies. Please refer to the PCB Layout Guide for more details.

External Bootstrap Diode

Add an external bootstrap diode if the input voltage is no greater than 5V or if the 5V rail is available. This diode improves regulator efficiency. The bootstrap diode can be a low-cost one, such as the IN4148 or the BAT54.

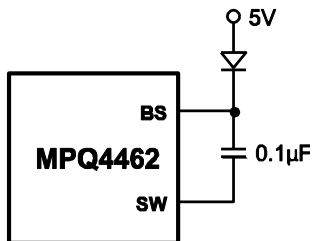

Figure 3: External Bootstrap Diode

This diode is also recommended for high-duty-cycle operation (when $V_{OUT} / V_{IN} > 65\%$) or low V_{IN} (<5V) applications.

At no load or light load, the converter may operate in pulse-skipping mode to maintain output-voltage regulation. However, pulse-skipping limits the BST voltage's charging time. For sufficient gate voltage, make sure that $V_{IN} - V_{OUT} > 3V$. For example, if V_{OUT} is 3.3V, V_{IN} needs to be higher than $3.3V + 3V = 6.3V$ to maintain the BST voltage at no load or light load. To meet this requirement, use the EN pin to program the input UVLO voltage to $V_{OUT} + 3V$.

TYPICAL APPLICATION CIRCUITS

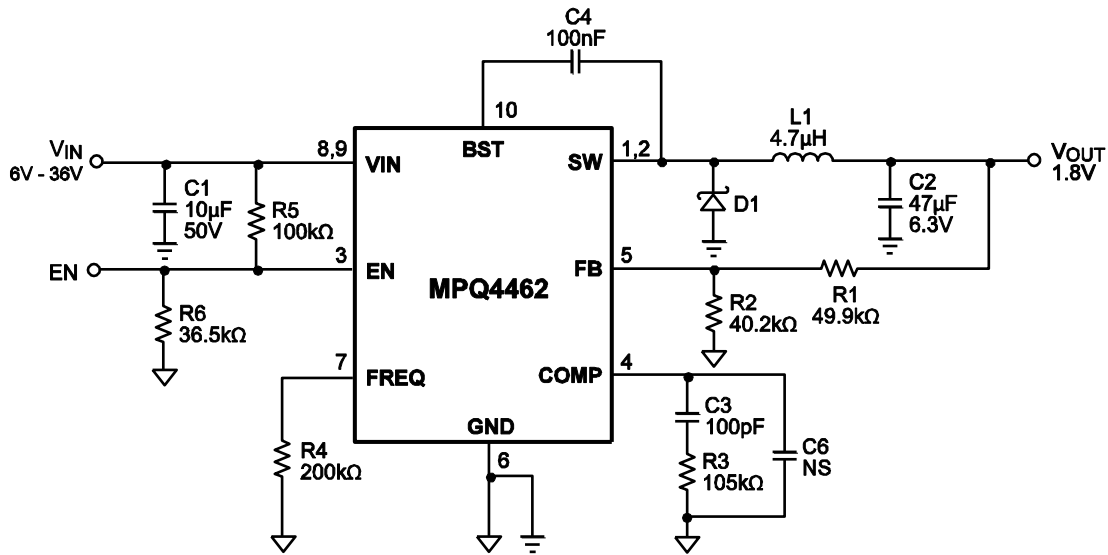

Figure 4: Typical Application, 1.8V Output

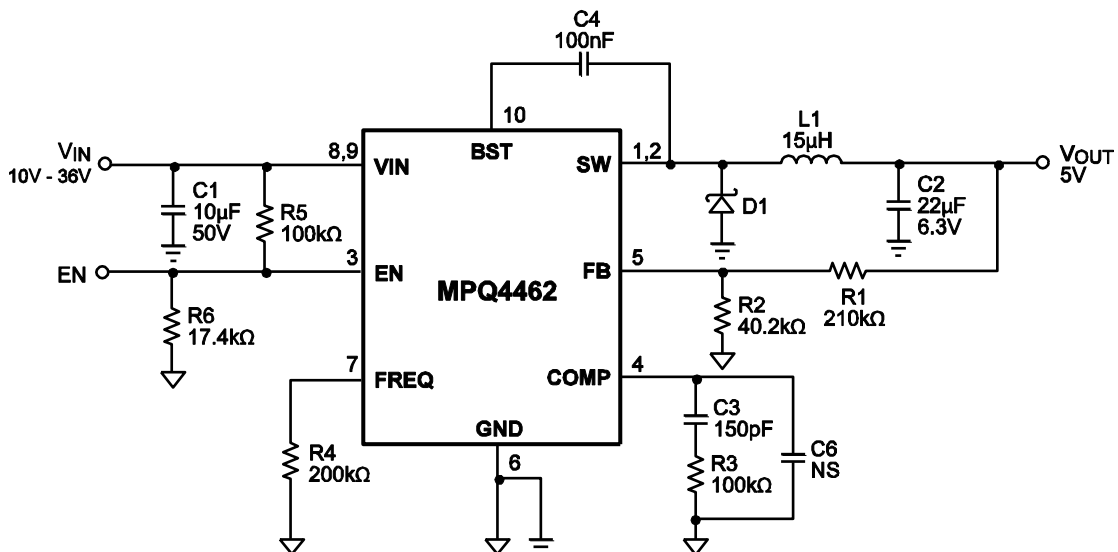

Figure 5: Typical Application, 5V Output

PCB LAYOUT GUIDE

PCB layout is very important for system stability. It is highly recommended to duplicate EVB layout for optimum performance.

If change is necessary, please follow these guidelines and take Figure 6 for reference.

- 1) Keep the path of switching current short and minimize the loop area formed by input capacitor, high-side MOSFET and external switching diode. Place ceramic bypass capacitors close to the VIN Pin.
 - 2) Make all feedback connections short and direct. Try to run the feedback trace as far from the inductor and noisy power traces as possible. If possible run the feedback trace on the opposite PCB side to the inductor with a ground plane separating the two.
 - 3) Place the feedback resistors and compensation components as close to the chip as possible. Do not place the compensation components close to or under high dv/dt SW node, or inside the high di/dt power loop. If you have to do so,
- the proper ground plane must be in place to isolate those.
 - 4) Connect VIN, SW, and especially GND respectively to large copper areas to cool the chip to improve thermal performance and long-term reliability. To help to improve the thermal conduction at high frequencies, add a grid of thermal vias under the exposed pad. Use small vias (15mil barrel diameter) so that the hole fills up during the plating process and improve thermal conduction. Larger vias can cause solder wicking during the reflow process. A pitch (distance between the centers) of 40mil between thermal vias is typical.
 - 5) Place the input decoupling capacitor, catch diode and the MPQ4462 (VIN, SW and PGND) as close as possible, with traces that are very short and fairly wide. This can help to greatly reduce the voltage spike on SW node, and lower the EMI noise level as well.
 - 6) Please refer to the layout example on EVQ4460 datasheet.

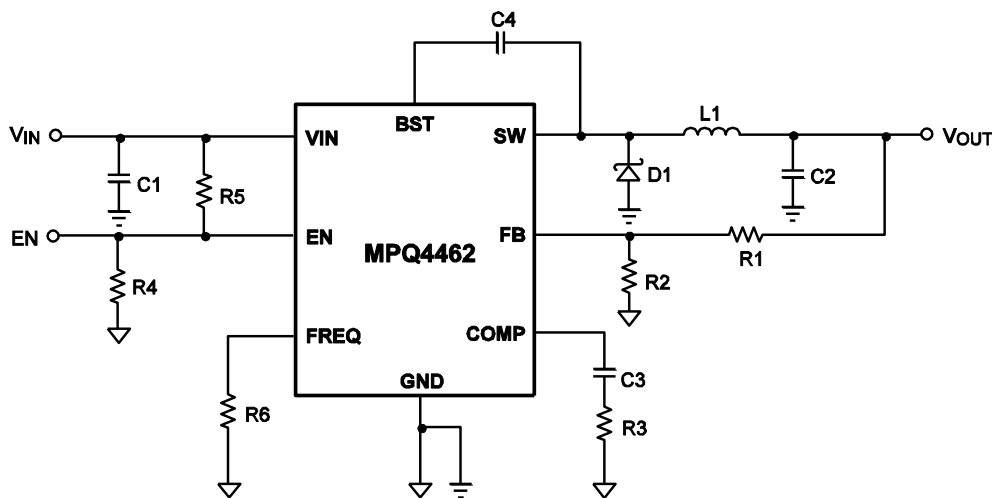
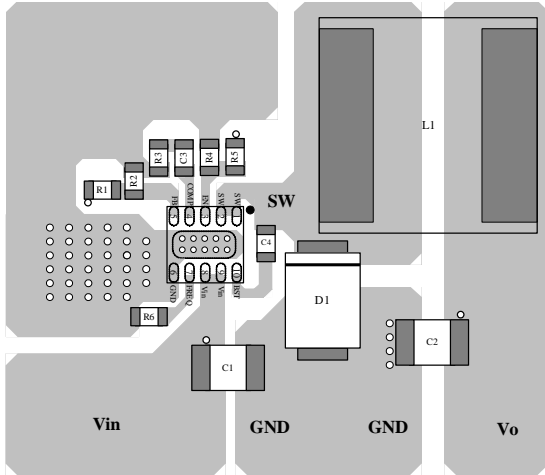
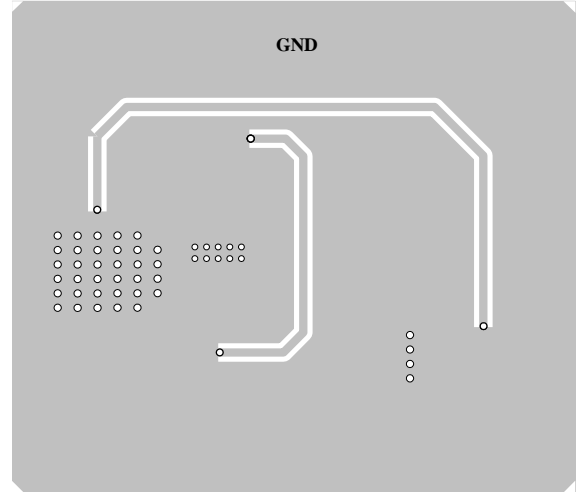

Figure 6: Typical Application Circuit



MPQ4462DQ Top Layer



MPQ4462DQ Bottom Layer

PACKAGE INFORMATION

3mm x 3mm QFN10

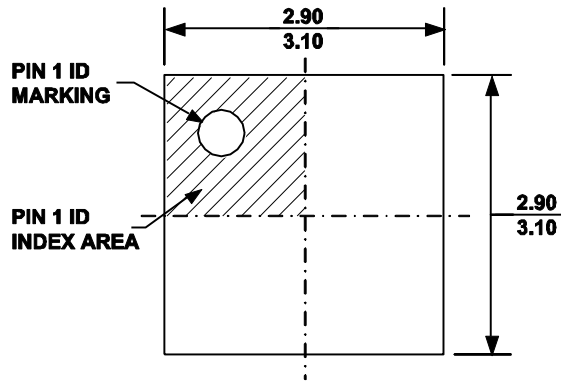

TOP VIEW

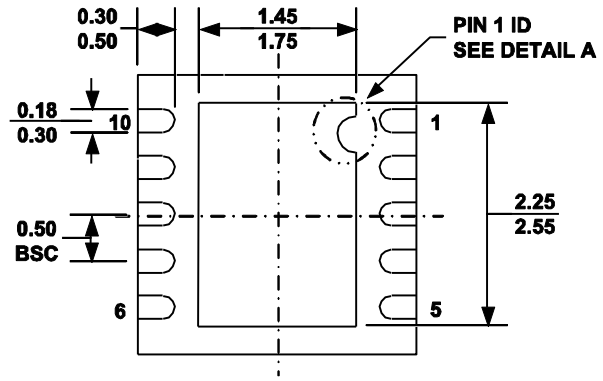

BOTTOM VIEW

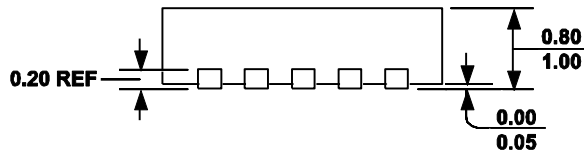

SIDE VIEW

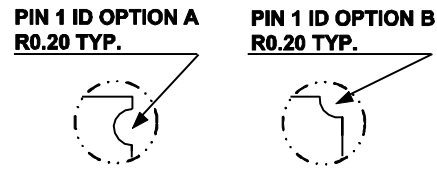

DETAIL A

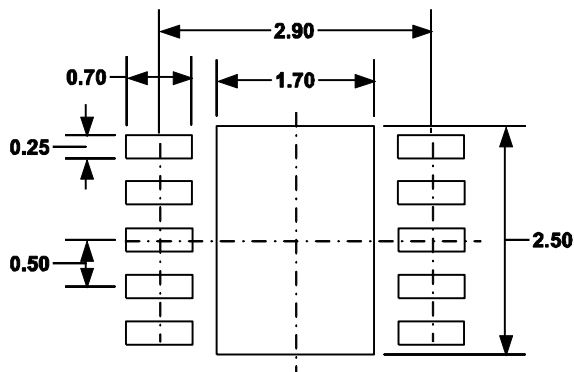

RECOMMENDED LAND PATTERN

NOTE:

- 1) ALL DIMENSIONS ARE IN MILLIMETERS.
- 2) EXPOSED PADDLE SIZE DOES NOT INCLUDE MOLD FLASH.
- 3) LEAD COPLANARITY SHALL BE 0.10 MILLIMETER MAX.
- 4) DRAWING CONFORMS TO JEDEC MO-229, VARIATION VEED-5.
- 5) DRAWING IS NOT TO SCALE.

SOIC8E

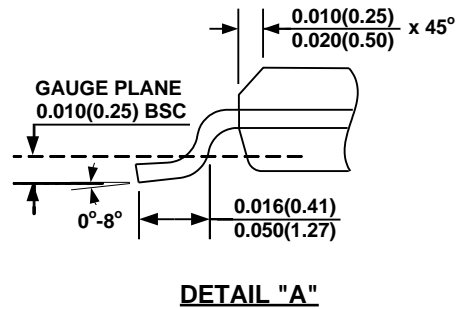
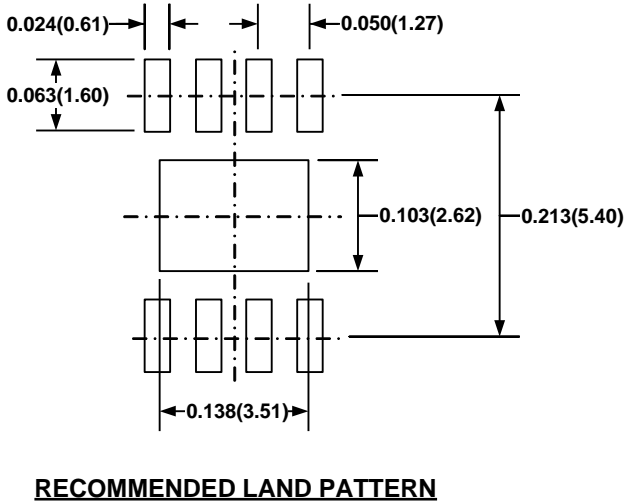
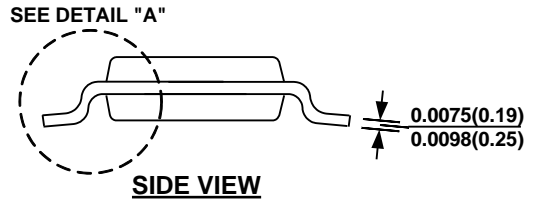
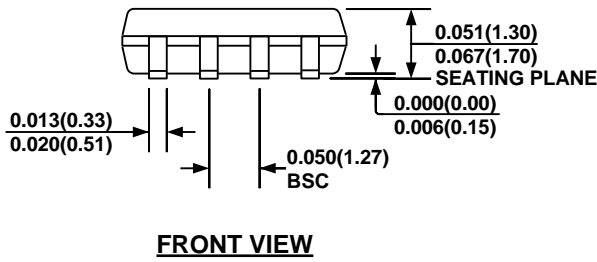
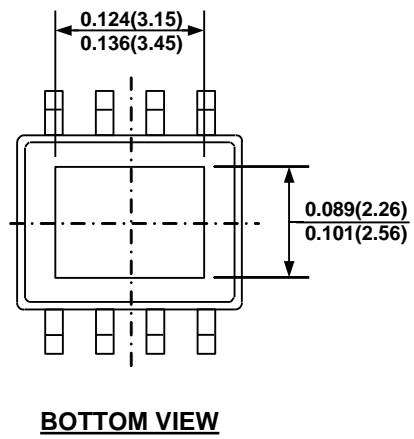
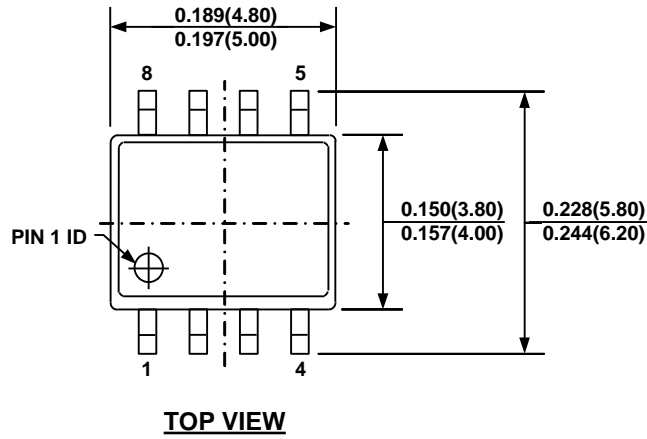

NOTE:

- 1) CONTROL DIMENSION IS IN INCHES. DIMENSION IN BRACKET IS IN MILLIMETERS.
- 2) PACKAGE LENGTH DOES NOT INCLUDE MOLD FLASH, PROTRUSIONS OR GATE BURRS.
- 3) PACKAGE WIDTH DOES NOT INCLUDE INTERLEAD FLASH OR PROTRUSIONS.
- 4) LEAD COPLANARITY (BOTTOM OF LEADS AFTER FORMING) SHALL BE 0.004" INCHES MAX.
- 5) DRAWING CONFORMS TO JEDEC MS-012, VARIATION BA.
- 6) DRAWING IS NOT TO SCALE.

NOTICE: The information in this document is subject to change without notice. Users should warrant and guarantee that third party Intellectual Property rights are not infringed upon when integrating MPS products into any application. MPS will not assume any legal responsibility for any said applications.

X-ON Electronics

Largest Supplier of Electrical and Electronic Components

Click to view similar products for [Switching Voltage Regulators](#) category:

Click to view products by [Monolithic Power Systems](#) manufacturer:

Other Similar products are found below :

[FAN53610AUC33X](#) [FAN53611AUC123X](#) [FAN48610BUC33X](#) [FAN48610BUC45X](#) [FAN48617UC50X](#) [R3](#) [430464BB](#) [KE177614](#)
[MAX809TTR](#) [NCV891234MW50R2G](#) [NCP81103MNTXG](#) [NCP81203PMNTXG](#) [NCP81208MNTXG](#) [NCP81109GMNTXG](#)
[SCY1751FCCT1G](#) [NCP81109JMNTXG](#) [AP3409ADNTR-G1](#) [NCP81241MNTXG](#) [LTM8064IY](#) [LT8315EFE#TRPBF](#) [NCV1077CSTBT3G](#)
[XCL207A123CR-G](#) [MPM54304GMN-0002](#) [MPM54304GMN-0003](#) [XDPE132G5CG000XUMA1](#) [DA9121-B0V76](#) [MP8757GL-P](#)
[MIC23356YFT-TR](#) [LD8116CGL](#) [HG2269M/TR](#) [OB2269](#) [XD3526](#) [U6215A](#) [U6215B](#) [U6620S](#) [LTC3803ES6#TR](#) [LTC3803ES6#TRM](#)
[LTC3412IFE](#) [LT1425IS](#) [MAX25203BATJA/VY+](#) [MAX77874CEWM+](#) [XC9236D08CER-G](#) [ISL95338IRTZ](#) [MP3416GJ-P](#) [BD9S201NUX-](#)
[CE2](#) [MP5461GC-Z](#) [MPQ4415AGQB-Z](#) [MPQ4590GS-Z](#) [MCP1603-330IMC](#) [MCP1642B-18IMC](#)