

■ PRODUCT CHARACTERISTICS

BVCBO	700V
BVCEO	400V
HFE@5V2A	8-40
IC	8A

Symbol

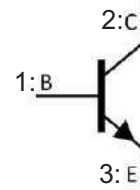

■ APPLICATIONS

- Fluorescent lamp
- Electronic ballast
- Electronic transformer
- Switch mode power supply

■ FEATURES

- \*  $V_{CEO(SUS)}$  400V
- \* 700V Blocking Capability

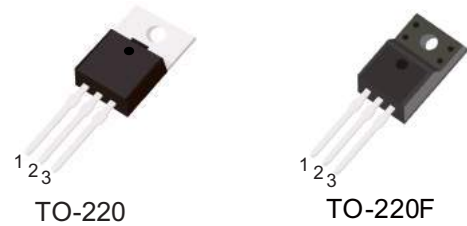

■ ORDER INFORMATION

Order codes		Package	Packing
Halogen-Free	Halogen		
N/A	MOT13007MF	TO-220F	50 pieces/Tube
N/A	MOT13007MA	TO-220	50 pieces/Tube

■ ABSOLUTE MAXIMUM RATING

PARAMETER	SYMBOL	RATINGS	UNIT
Collector-Emitter Sustaining Voltage	$V_{CEO}$	400	V
Collector-Emitter Breakdown Voltage	$V_{CBO}$	700	V
Emitter-Base Voltage	$V_{EBO}$	9.0	V
Collector Current	Continuous	$I_C$	8.0
	Peak (1)	$I_{CM}$	16
Base Current	Continuous	$I_B$	4.0
	Peak (1)	$I_{BM}$	8.0
Emitter Current	Continuous	$I_E$	12
	Peak (1)	$I_{EM}$	24
Total Device Dissipation	$T_C = 25^\circ C$	$P_D$	80
Operating and Storage Junction Temperature	$T_J, T_{STG}$		-55~+150
			$^\circ C$

Note: Absolute maximum ratings are those values beyond which the device could be permanently damaged. Absolute maximum ratings are stress ratings only and functional device operation is not implied.

■ THERMAL DATA

PARAMETER	SYMBOL	RATINGS	UNIT
Junction to Case	$\theta_{JC}$	1.56	$^\circ C/W$
Junction to Ambient	$\theta_{JA}$	62.5	$^\circ C/W$

Note 1: Pulse Test: Pulse Width = 5.0 ms, Duty Cycle  $\leq 10\%$ .

Measurement made with thermocouple contacting the bottom insulated mounting surface of the package (in a location beneath the die), the device mounted on a heatsink with thermal grease applied at a mounting torque of 6 to 8•lbs.

■ ELECTRICAL CHARACTERISTICS ( $T_C=25^\circ\text{C}$ , unless otherwise noted)

PARAMETER	SYMBOL	TEST CONDITIONS	MIN	TYP	MAX	UNIT
Collector-Emitter Sustaining Voltage	$V_{CEO(SUS)}$	$I_C=10\text{mA}, I_B=0$	400			V
Collector Cutoff Current	$I_{CBO}$	$V_{CES}=700\text{V}$			0.1	mA
		$V_{CES}=700\text{V}, T_C=125^\circ\text{C}$			1.0	mA
Emitter Cutoff Current	$I_{EBO}$	$V_{EB}=9.0\text{V}, I_C=0$			100	$\mu\text{A}$
DC Current Gain	$h_{FE1}$	$I_C=2.0\text{A}, V_{CE}=5.0\text{V}$	8.0		40	
	$h_{FE2}$	$I_C=5.0\text{A}, V_{CE}=5.0\text{V}$	5.0		30	
Collector-Emitter Saturation Voltage	$V_{CE(SAT)}$	$I_C=2.0\text{A}, I_B=0.4\text{A}$			1.0	V
		$I_C=5.0\text{A}, I_B=1.0\text{A}$			2.0	V
		$I_C=8.0\text{A}, I_B=2.0\text{A}$			3.0	V
		$I_C=5.0\text{A}, I_B=1.0\text{A}, T_C=100^\circ\text{C}$			3.0	V
Base-Emitter Saturation Voltage	$V_{BE(SAT)}$	$I_C=2.0\text{A}, I_B=0.4\text{A}$			1.2	V
		$I_C=5.0\text{A}, I_B=1.0\text{A}$			1.6	V
		$I_C=5.0\text{A}, I_B=1.0\text{A}, T_C=100^\circ\text{C}$			1.5	V
Current-Gain-Bandwidth Product	$f_T$	$I_C=500\text{mA}, V_{CE}=10\text{V}, f=1.0\text{MHz}$	4.0	14		MHz
Output Capacitance	$C_{ob}$	$V_{CB}=10\text{V}, I_E=0, f=0.1\text{MHz}$		80		pF
Resistive Load (Table 1)						
Delay Time	$t_D$	$V_{CC}=125\text{V}, I_C=5.0\text{A},$ $I_{B1}=I_{B2}=1.0\text{A}, t_p=25\mu\text{s},$ Duty Cycle $\leq 1.0\%$		0.025	0.1	$\mu\text{s}$
Rise Time	$t_R$			0.5	1.5	$\mu\text{s}$
Storage Time	$t_S$			1.8	3.0	$\mu\text{s}$
Fall Time	$t_F$			0.23	0.7	$\mu\text{s}$

\* Pulse Test: Pulse Width $\leq 300\mu\text{s}$ , Duty Cycle $\leq 2.0\%$

■ TYPICAL CHARACTERISTICS

Figure 2. Base-Emitter Saturation Voltage

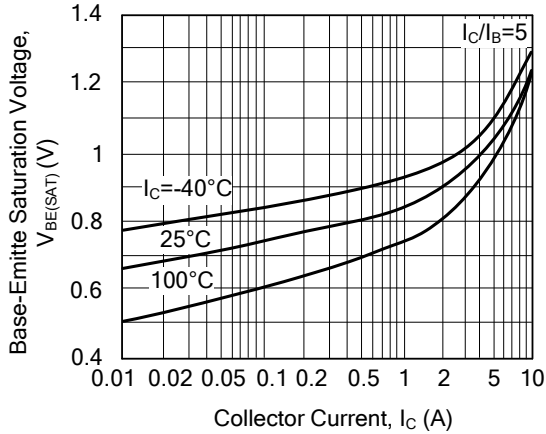

Figure 3. Collector-Emitter Saturation Voltage

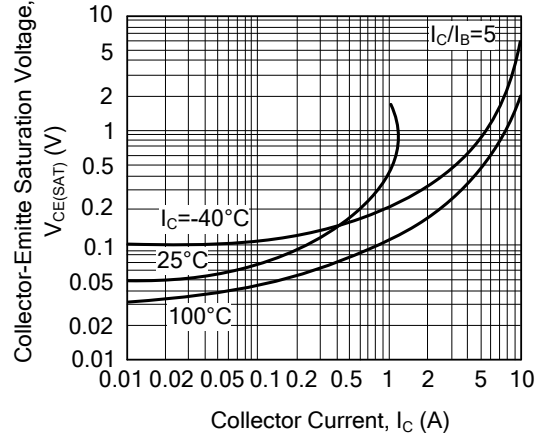

Figure 4. Collector Saturation Region

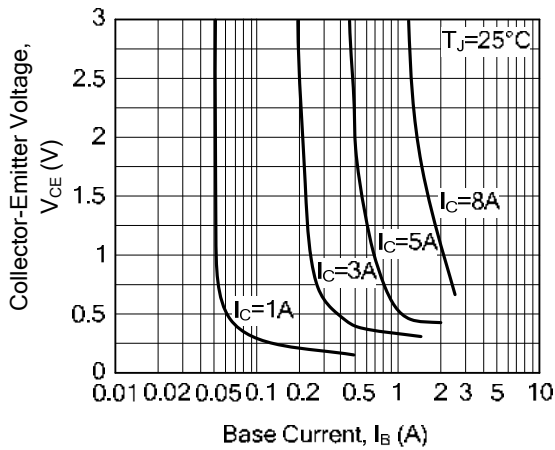

Figure 5. DC Current Gain

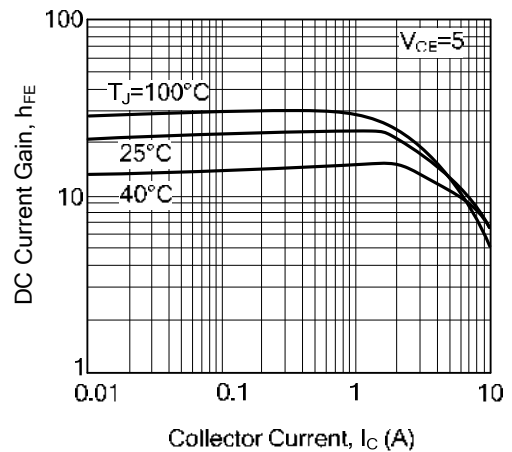

Figure 6. Capacitance

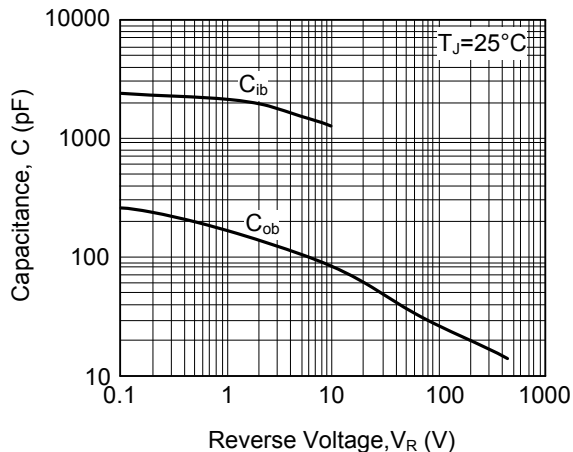
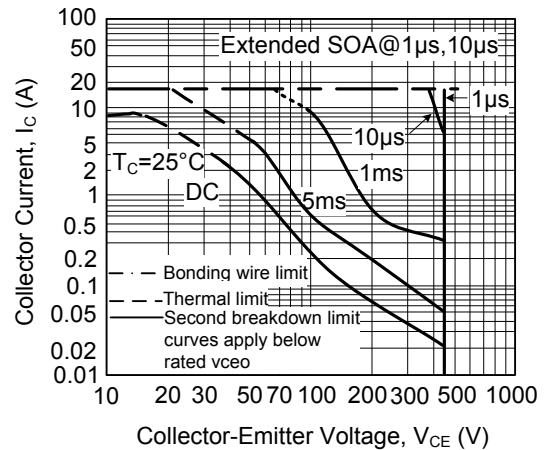

Figure 7. Maximum Forward Bias Safe Operating Area



■ TYPICAL CHARACTERISTICS(Cont.)

Figure 8. Maximum Reverse Bias Switching Safe Operating Area

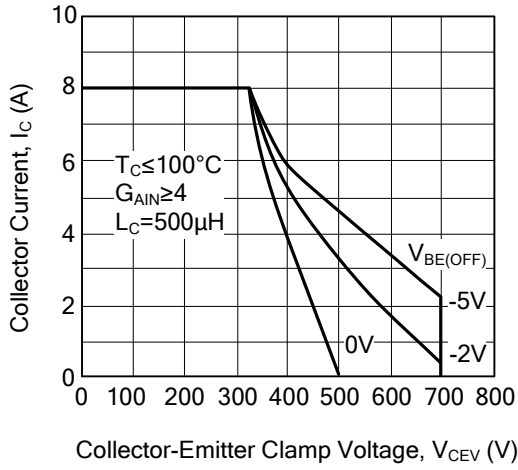

Figure 9. Forward Bias Power Derating

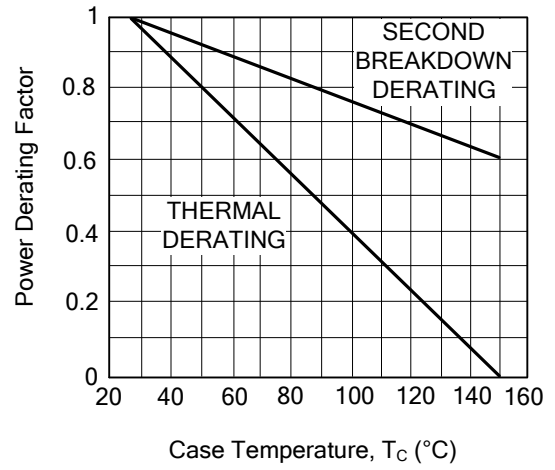

Figure 10. Turn-On Time(Resistive Load)

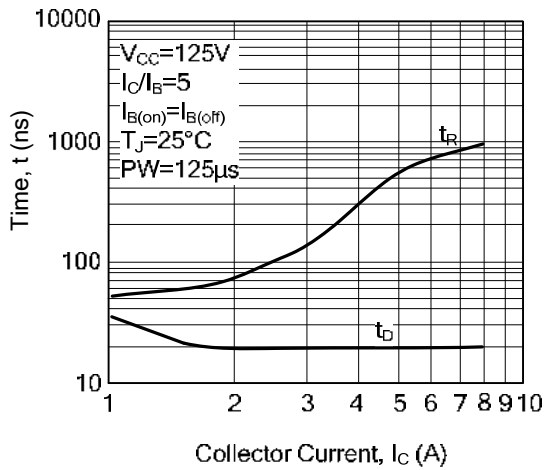
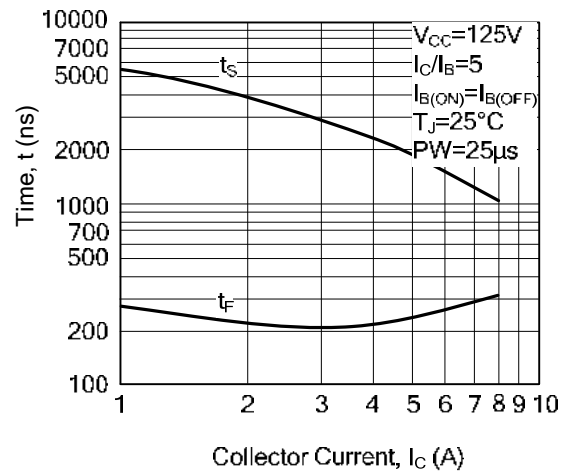
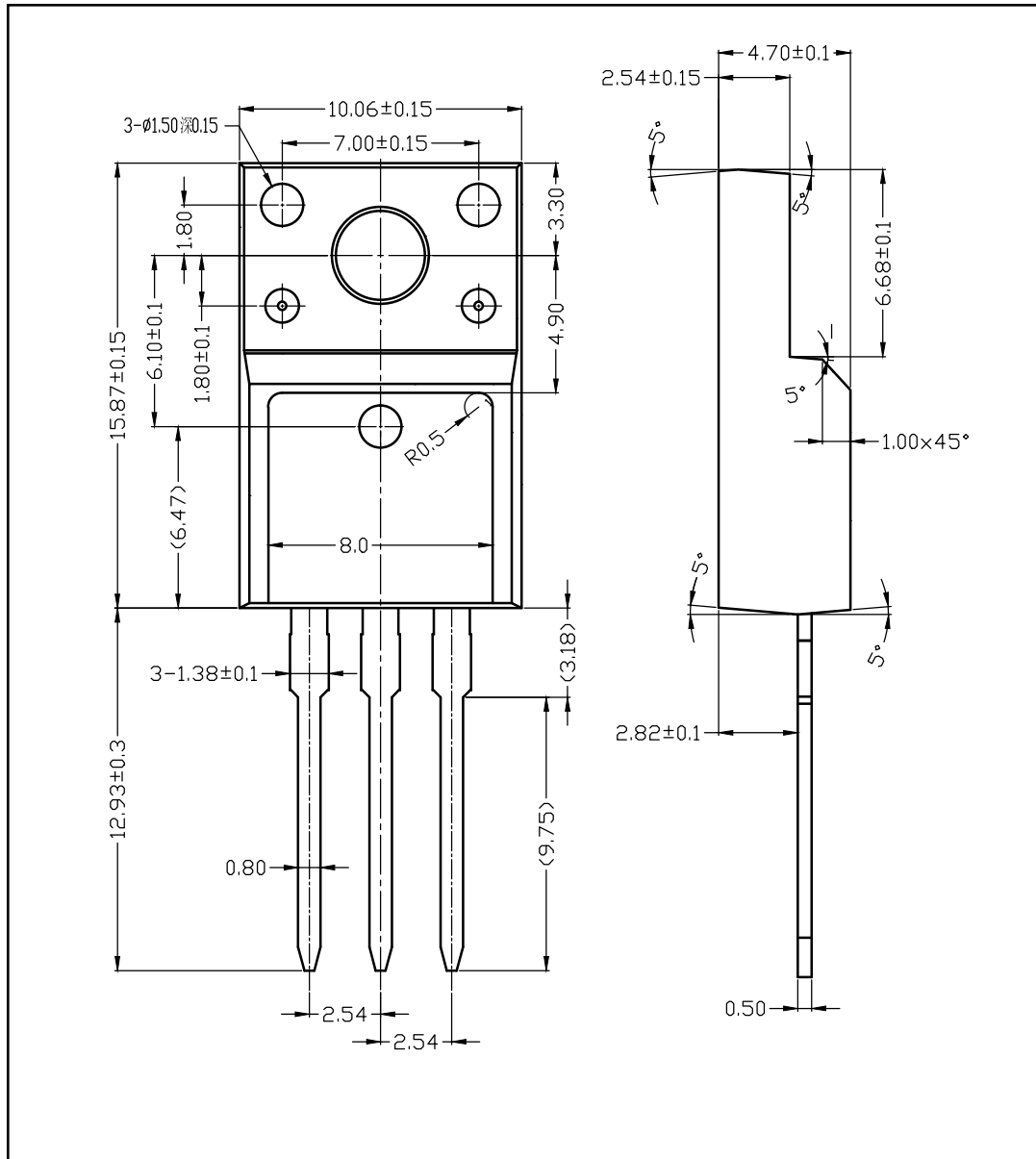

Figure 11. Turn-Off Time(Resistive Load)



■ TO-220F-3L PACKAGE OUTLINE DIMENSIONS



■ TO-220-3L PACKAGE OUTLINE DIMENSIONS

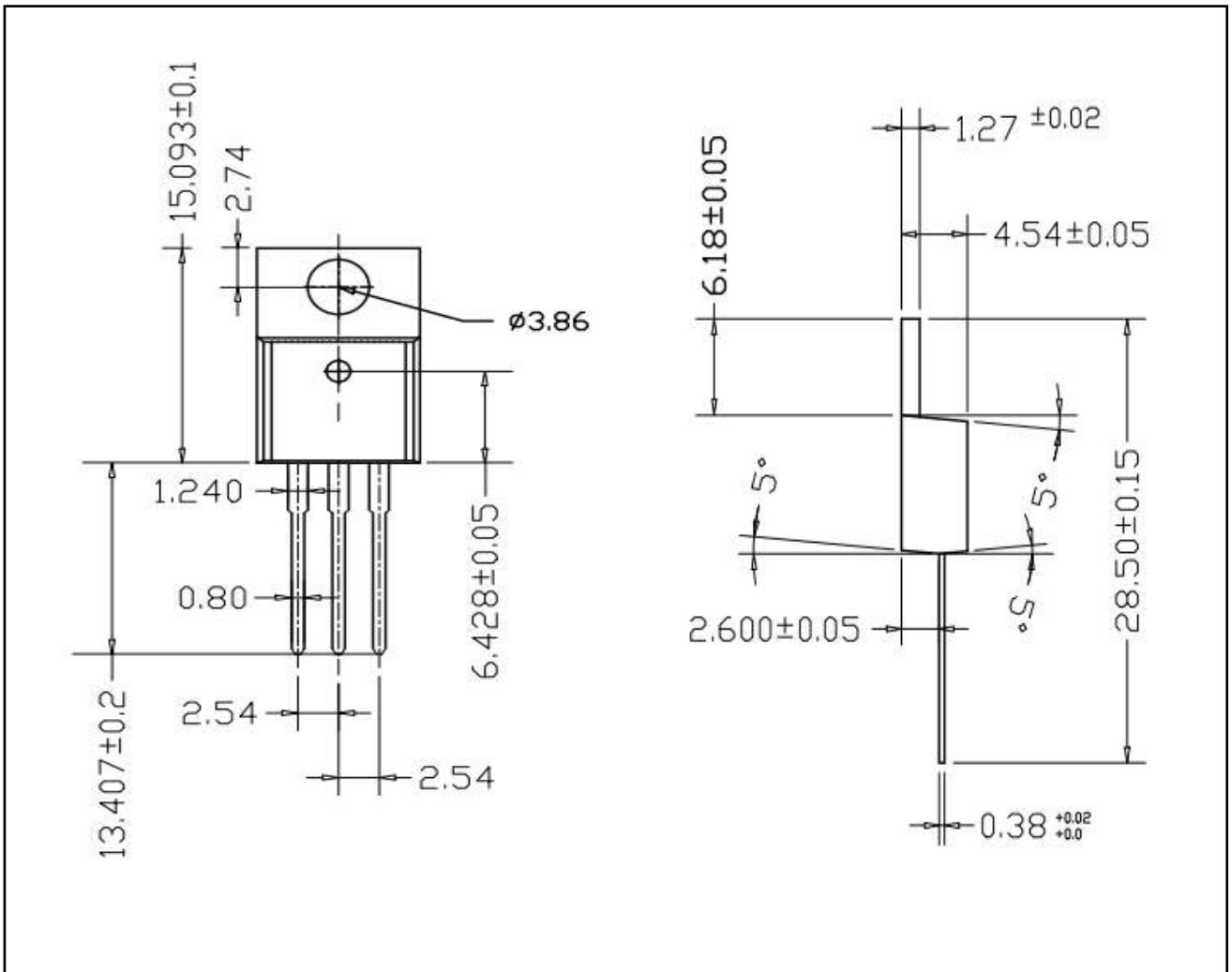

## X-ON Electronics

Largest Supplier of Electrical and Electronic Components

*Click to view similar products for [Bipolar Transistors - BJT category](#):*

*Click to view products by [MOT manufacturer](#):*

Other Similar products are found below :

[BC559C](#) [MCH4017-TL-H](#) [MMBT-2369-TR](#) [BC546/116](#) [NJVMJD148T4G](#) [NTE16](#) [NTE195A](#) [IMX9T110](#) [2N4401-A](#) [2N6728](#) [2SA1419T-TD-H](#) [2SB1204S-TL-E](#) [2SC5488A-TL-H](#) [FMC5AT148](#) [2N2369ADCSM](#) [2N2907A](#) [2N3904-NS](#) [2N5769](#) [2SC4618TLN](#) [CPH6501-TL-E](#) [US6T6TR](#) [BAX18/A52R](#) [BC556/112](#) [IMZ2AT108](#) [MMST8098T146](#) [MCH6102-TL-E](#) [BC846B-13-F](#) [2N3879](#) [30A02MH-TL-E](#) [NTE13](#) [NTE282](#) [NTE323](#) [NTE350](#) [NTE81](#) [JANTX2N2920L](#) [JANSR2N2907AUB](#) [CMLT3946EG TR](#) [SNSS40600CF8T1G](#) [CMLT3906EG TR](#) [GRP-DATA-JANS2N2907AUB](#) [GRP-DATA-JANS2N2222AUA](#) [MMDT3946FL3-7](#) [2N4240](#) [JANS2N3019](#) [MSB30KH-13](#) [2N2221AUB](#) [2SD1815T-TL-E](#) [2N6678](#) [2N2907Ae4](#) [JAN2N3507](#)