

PRODUCT CHARACTERISTICS

VDSS	30V
$R_{DS(on)typ}(V_{GS}=4.5V)$	4.5mΩ
$R_{DS(on)typ}(V_{GS}=10V)$	3.4mΩ
Qg@type	50nC
ID	100A

APPLICATIONS

- Switching applications

FEATURES

- $R_{DS(on)} * Q_g$ industry's benchmark
- Conduction losses reduced
- Switching losses reduced
- Low threshold device

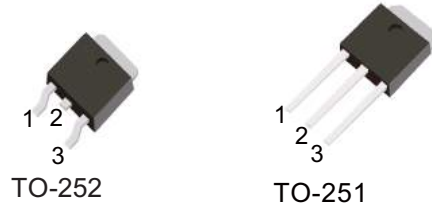
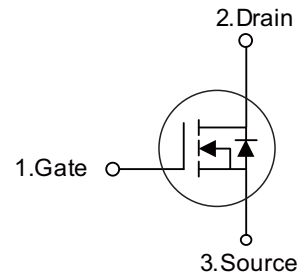
Symbol

ORDER INFORMATION

Order codes		Package	Packing
Halogen-Free	Halogen		
N/A	MOT100N03MD	TO-252	2500 pieces /Reel
N/A	MOT100N03MC	TO-251	70 pieces /Tube

ABSOLUTE MAXIMUM RATINGS (T_C =25°C, unless otherwise specified)

PARAMETER	SYMBOL	RATINGS	UNIT
Drain-Source Voltage	V _{DSS}	30	V
Gate-Source Voltage	V _{GSS}	±20	V
Continuous Drain Current	I _D	100	A
Continuous Drain Current (T _C =100°C)	I _D	70	A
Pulsed Drain Current (Note 2)	I _{DM}	400	A
Single Pulsed Avalanche Current (Note 3)	I _{AS}	35	A
Single Pulsed Avalanche Energy (Note 3)	E _{AS}	400	mJ
Power Dissipation	P _D	50	W
Derate above 25°C		0.4	W/°C
Junction Temperature	T _J	+175	°C
Strong Temperature	T _{STG}	-55 ~ +175	°C

Note: 1. Absolute maximum ratings are those values beyond which the device could be permanently damaged.

Absolute maximum ratings are stress ratings only and functional device operation is not implied.

2. Pulse width limited by maximum junction temperature

3. L = 0.5mH, I_{AS} = 30A, V_{DD} = 25V, R_G = 25Ω, Starting T_J = 25°C.

THERMAL DATA

PARAMETER	SYMBOL	RATINGS	UNIT
Junction to Ambient	θ _{JA}	110	°C/W
Junction to Case	θ _{JC}	2.5	°C/W

■ ELECTRICAL CHARACTERISTICS ($T_J = 25^\circ\text{C}$, unless otherwise noted)

PARAMETER	SYMBOL	TEST CONDITIONS	MIN	TYP	MAX	UNIT
OFF CHARACTERISTICS						
Drain-Source Breakdown Voltage	BV_{DSS}	$V_{GS} = 0\text{ V}, I_D = 250\ \mu\text{A}$	30	-	-	V
Drain-Source Leakage Current	I_{DSS}	$V_{DS} = 30\text{ V}, V_{GS} = 0\text{ V}$	-	-	1	μA
Gate-Source Leakage Current	I_{GSS}	$V_{DS} = 0\text{ V}, V_{GS} = \pm 20\text{ V}$	-	-	± 100	nA
ON CHARACTERISTICS (Note2)						
Gate Threshold Voltage	$V_{GS(TH)}$	$V_{DS} = V_{GS}, I_D = 250\ \mu\text{A}$	1	-	3	V
Static Drain-Source On-Resistance	$R_{DS(ON)}$	$V_{GS} = 10\text{ V}, I_D = 20\text{ A}$	-	3.4	4.5	m Ω
		$V_{GS} = 4.5\text{ V}, I_D = 20\text{ A}$	-	4.7	6	
DYNAMIC PARAMETERS (Note3)						
Input Capacitance	C_{ISS}	$V_{DS} = 15\text{ V}, V_{GS} = 0\text{ V}, f = 1.0\text{ MHz}$	-	2500	-	pF
Output Capacitance	C_{OSS}		-	300	-	
Reverse Transfer Capacitance	C_{RSS}		-	300	-	
SWITCHING PARAMETERS (Note3)						
Total Gate Charge	Q_G	$V_{DS} = 15\text{ V}, V_{GS} = 5\text{ V}, I_D = 16\text{ A}$	-	50	-	nC
Gate Source Charge	Q_{GS}		-	20.8	-	
Gate Drain Charge	Q_{GD}		-	19	-	
Turn-ON Delay Time	$t_{D(ON)}$	$V_{DD} = 15\text{ V}, I_D = 1\text{ A}, R_{GEN} = 6\ \Omega$ $V_{GS} = 10\text{ V}$	-	25.7	-	ns
Turn-ON Rise Time	t_R		-	10	-	
Turn-OFF Delay Time	$t_{D(OFF)}$		-	128	-	
Turn-OFF Fall-Time	t_F		-	34	-	
SOURCE- DRAIN DIODE RATINGS AND CHARACTERISTICS						
Drain-Source Diode Forward Voltage	V_{SD}	$I_S = 20\text{ A}, V_{GS} = 0\text{ V}$	-	-	1.5	V
Drain-Source Diode Forward Current	I_S		-	-	90	A

Note: 1. Pulse Test : Pulse Width < 300 μs , Duty Cycle < 2%.
 2. Guaranteed by design, not subject to production testing.

■ TEST CIRCUIT AND WAVEFORM

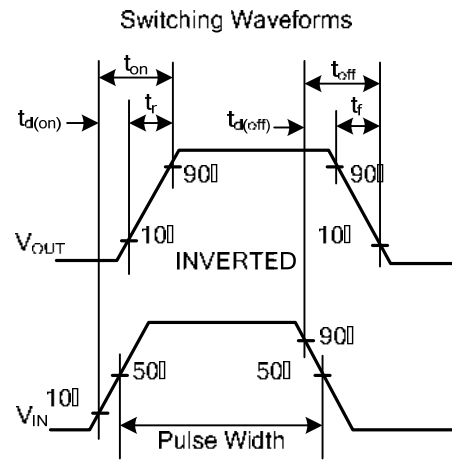
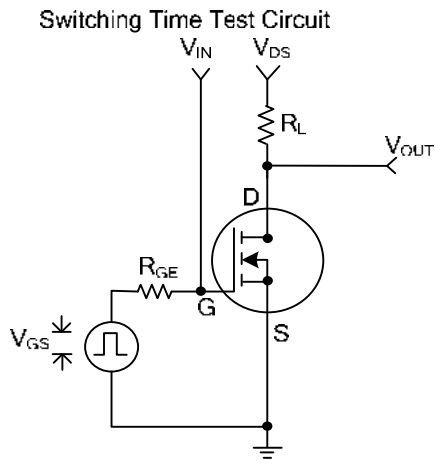

■ TYPICAL CHARACTERISTICS

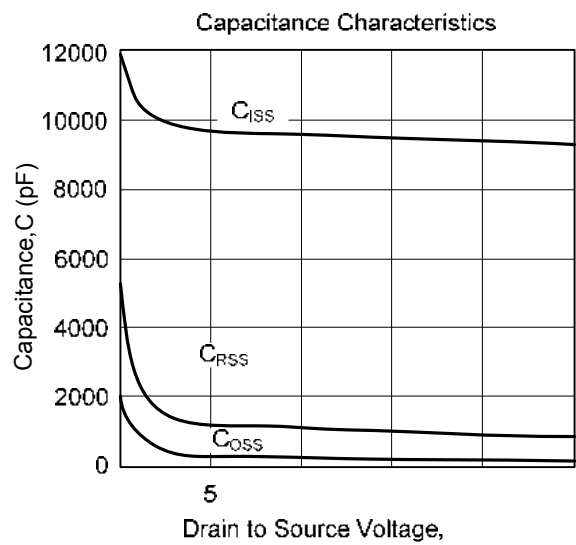
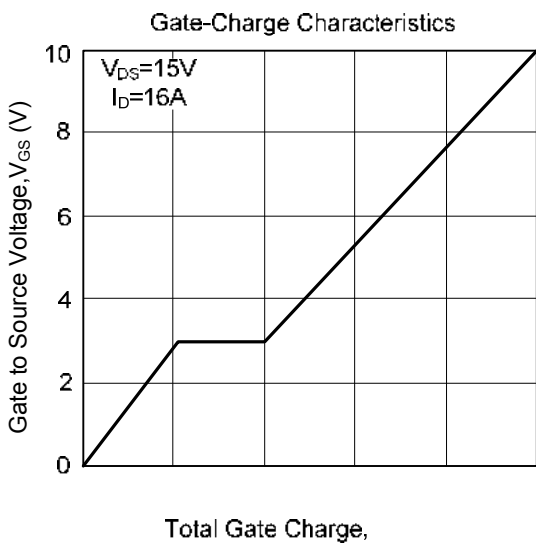
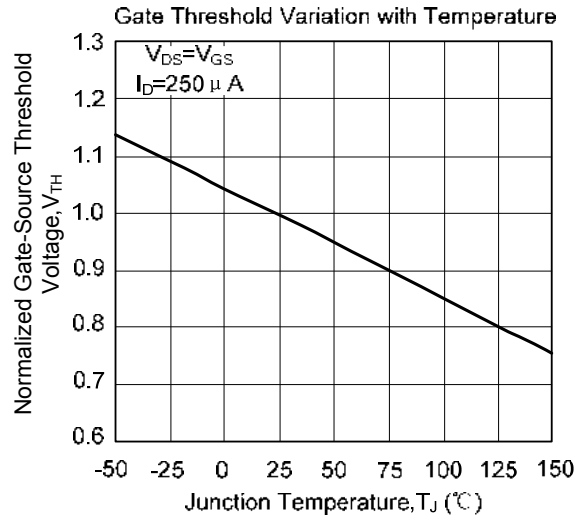
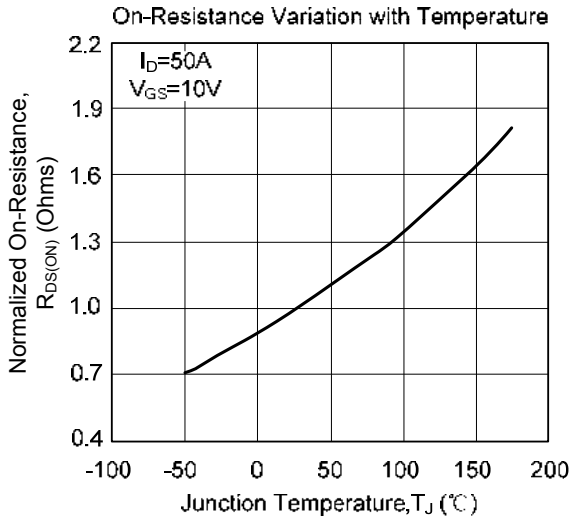
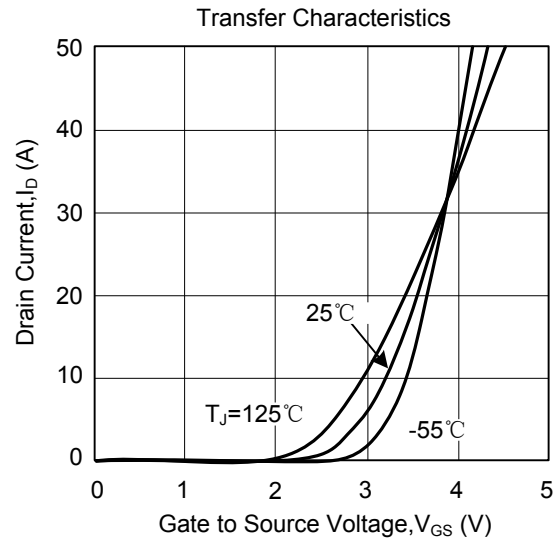
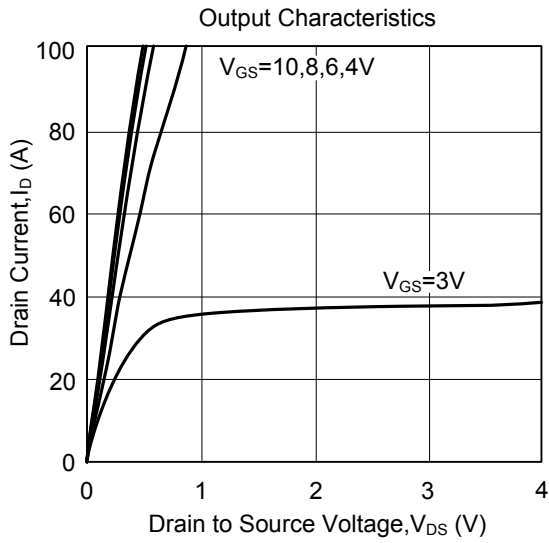

■ TYPICAL CHARACTERISTICS(Cont.)

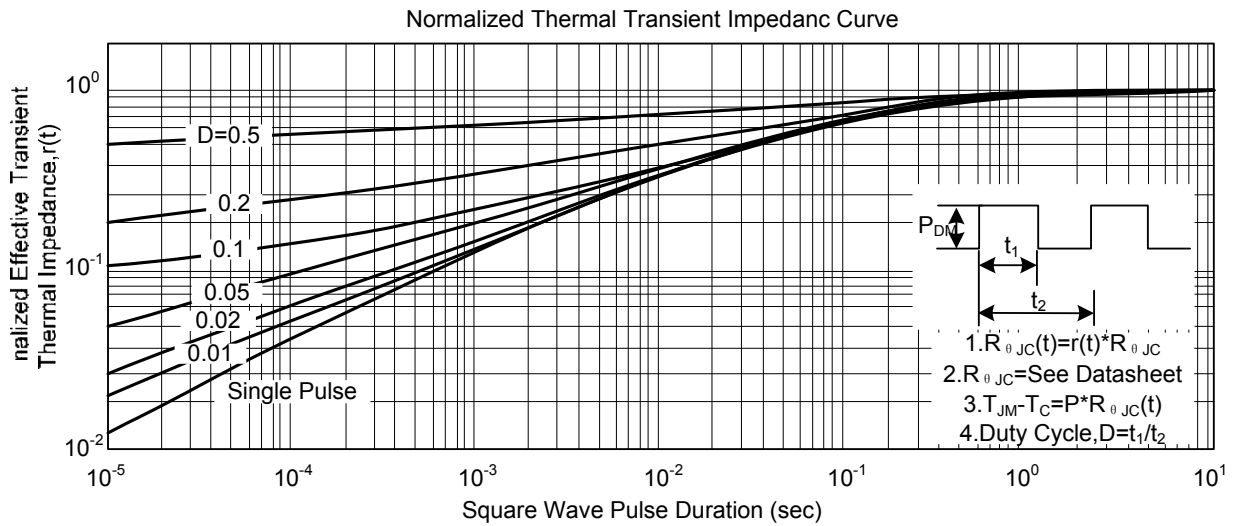
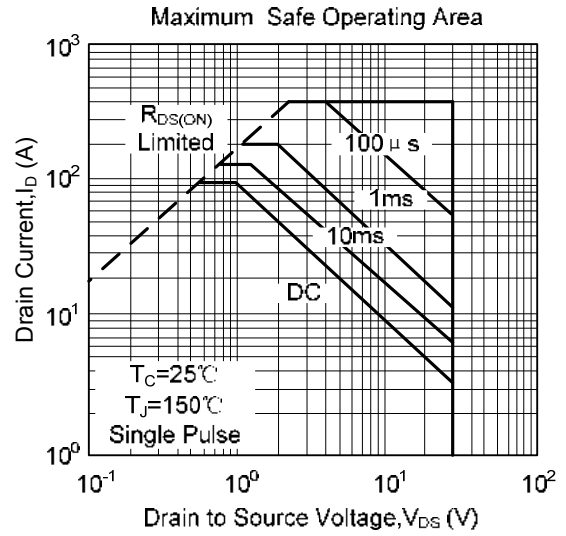
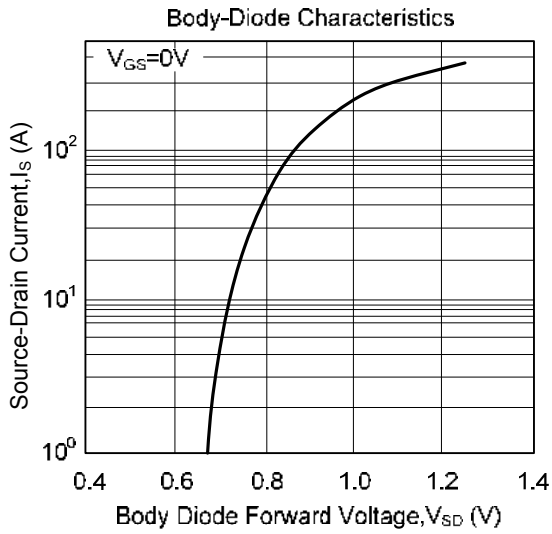

■ TO-251 PACKAGE OUTLINE DIMENSIONS

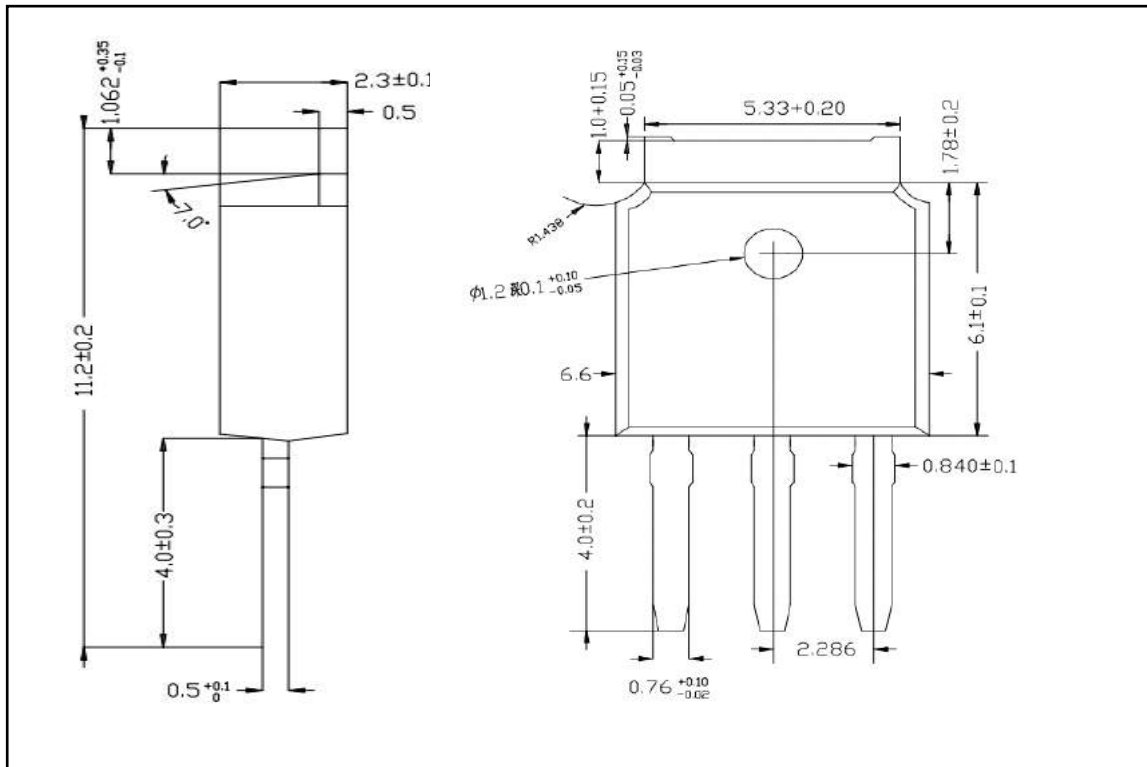

■ TO-252 PACKAGE OUTLINE DIMENSIONS

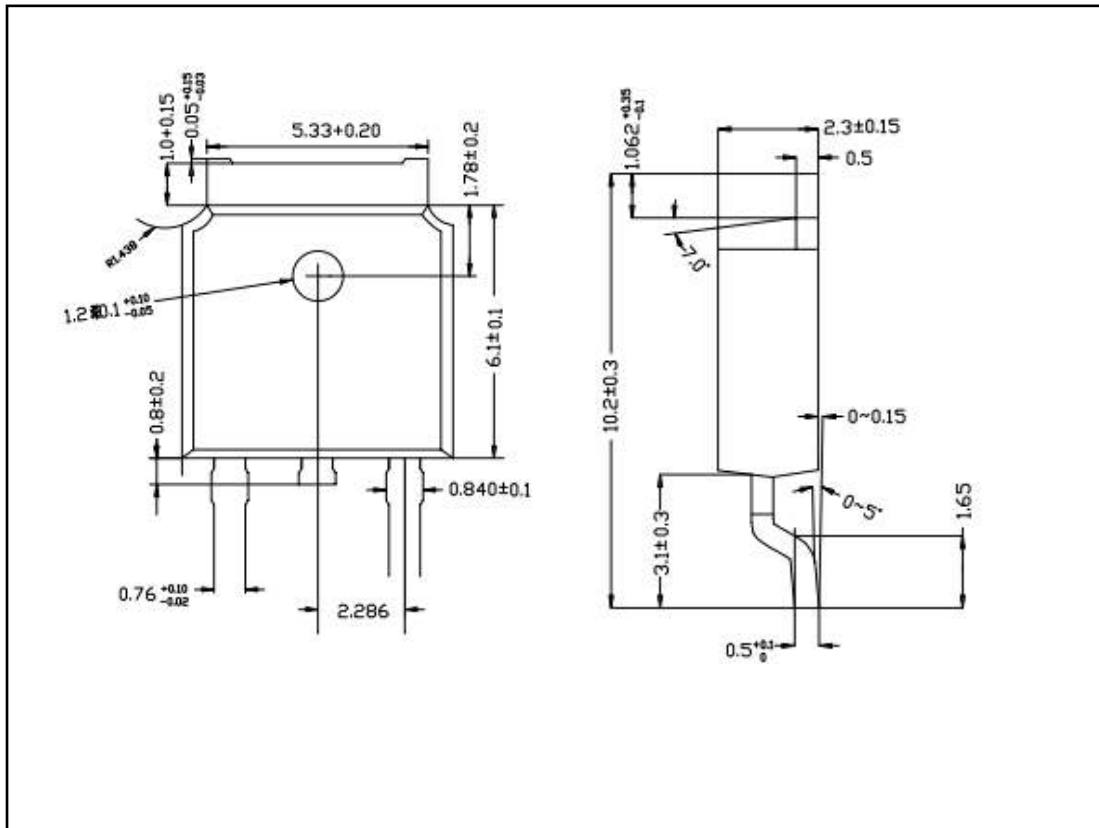

X-ON Electronics

Largest Supplier of Electrical and Electronic Components

Click to view similar products for [MOSFET](#) category:

Click to view products by [MOT](#) manufacturer:

Other Similar products are found below :

[IRFD120](#) [JANTX2N5237](#) [BUK455-60A/B](#) [MIC4420CM-TR](#) [VN1206L](#) [NDP4060](#) [SI4482DY](#) [IPS70R2K0CEAKMA1](#) [SQD23N06-31L-GE3](#)
[TK16J60W,S1VQ\(O](#) [2SK2614\(TE16L1,Q\)](#) [DMN1017UCP3-7](#) [DMN1053UCP4-7](#) [SQJ469EP-T1-GE3](#) [NTE2384](#) [DMC2700UDMQ-7](#)
[DMN2080UCB4-7](#) [DMN61D9UWQ-13](#) [US6M2GTR](#) [DMN31D5UDJ-7](#) [DMP22D4UFO-7B](#) [DMN1006UCA6-7](#) [DMN16M9UCA6-7](#)
[STF5N65M6](#) [IRF40H233XTMA1](#) [STU5N65M6](#) [DMN6022SSD-13](#) [DMN13M9UCA6-7](#) [DMTH10H4M6SPS-13](#) [DMN2990UFB-7B](#)
[IPB80P04P405ATMA2](#) [2N7002W-G](#) [MCAC30N06Y-TP](#) [MCQ7328-TP](#) [BXP7N65D](#) [BXP4N65F](#) [AOL1454G](#) [WMJ80N60C4](#) [BXP2N20L](#)
[BXP2N65D](#) [BXT1150N10J](#) [BXT1700P06M](#) [TSM60NB380CP](#) [ROG](#) [RQ7L055BGTCR](#) [DMNH15H110SK3-13](#) [SLF10N65ABV2](#)
[BSO203SP](#) [BSO211P](#) [IPA60R230P6](#) [IPA60R460CE](#)