

■ PRODUCT CHARACTERISTICS

BVCBO	700V
BVCEO	400V
HFE@5V2A	8-40
IC	4A

■ FEATURES

- * $V_{CEO(SUS)} = 400\text{ V}$
- * Reverse bias SOA with inductive loads @ $T_C = 100^\circ\text{C}$
- * Inductive switching matrix 2 to 4 Amp, 25 and 100°C
 t_c @ 3A, 100°C is 180 ns (Typ)
- * 700V blocking capability
- * SOA and switching applications information

■ APPLICATIONS

- * Switching regulator's, inverters
- * Motor controls
- * Solenoid/Relay drivers
- * Deflection circuits

Symbol

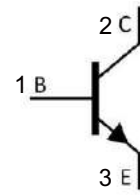

■ ORDER INFORMATION

Order codes		Package	Packing
Halogen-Free	Halogen		
N/A	MOT13005DF	TO-220F	50 pieces/Tube
N/A	MOT13005DA	TO-220	50 pieces/Tube

■ ABSOLUTE MAXIMUM RATINGS

PARAMETER	SYMBOL	RATINGS	UNIT	
Collector-Emitter Voltage	$V_{CEO(SUS)}$	400	V	
Collector-Emitter Voltage ($V_{BE}=0$)	V_{CES}	700	V	
Collector-Base Voltage	V_{CBO}	700	V	
Emitter Base Voltage	V_{EBO}	9	V	
Collector Current	Continuous	I_C	4	
	Peak (1)	I_{CM}	8	
Base Current	Continuous	I_B	2	
	Peak (1)	I_{BM}	4	
Emitter Current	Continuous	I_E	6	
	Peak (1)	I_{EM}	12	
Power Dissipation at $T_C=25^\circ\text{C}$	TO-220F	P_D	40	
	TO-220		75	
Derate above 25°C	TO-220F		320	mW/ $^\circ\text{C}$
	TO-220		600	
Operating and Storage Junction Temperature	T_J, T_{STG}	-65 ~ +150	$^\circ\text{C}$	

Note: Absolute maximum ratings are those values beyond which the device could be permanently damaged.

Absolute maximum ratings are stress ratings only and functional device operation is not implied.

■ THERMAL DATA

PARAMETER	SYMBOL	RATINGS	UNIT
Junction to Ambient	θ_{JA}	62.5	$^\circ\text{C/W}$
Junction to Case	θ_{JC}	1.67	$^\circ\text{C/W}$

■ ELECTRICAL CHARACTERISTICS ($T_C=25^\circ\text{C}$, unless otherwise noted)

PARAMETER	SYMBOL	TEST CONDITIONS	MIN	TYP	MAX	UNIT
OFF CHARACTERISTICS (Note 1)						
Collector-Emitter Sustaining Voltage	$V_{CEO(SUS)}$	$I_C=10\text{mA}$, $I_B=0$	400			V
Collector Cutoff Current	I_{CBO}	$V_{CBO}=\text{Rated Value}$, $V_{BE(OFF)}=1.5\text{V}$			1	mA
		$V_{CBO}=\text{Rated Value}$, $V_{BE(OFF)}=1.5\text{V}$, $T_C=100^\circ\text{C}$			5	
Emitter Cutoff Current	I_{EBO}	$V_{EB}=9\text{V}$, $I_C=0$			1	mA
SECOND BREAKDOWN						
Second Breakdown Collector Current with base forward biased	$I_{S/B}$				See Fig. 11	
Clamped Inductive SOA with Base Reverse Biased	RBSOA				See Fig. 12	
ON CHARACTERISTICS (Note 1)						
DC Current Gain	h_{FE1}	$I_C=0.5\text{A}$, $V_{CE}=5\text{V}$	20		40	
	h_{FE2}	$I_C=1\text{A}$, $V_{CE}=5\text{V}$	10		60	
	h_{FE3}	$I_C=2\text{A}$, $V_{CE}=5\text{V}$	8		40	
Collector-Emitter Saturation Voltage	$V_{CE(SAT)}$	$I_C=1\text{A}$, $I_B=0.2\text{A}$			0.5	V
		$I_C=2\text{A}$, $I_B=0.5\text{A}$			0.6	V
		$I_C=4\text{A}$, $I_B=1\text{A}$			1	V
		$I_C=2\text{A}$, $I_B=0.5\text{A}$, $T_a=100^\circ\text{C}$			1	V
Base-Emitter Saturation Voltage	$V_{BE(SAT)}$	$I_C=1\text{A}$, $I_B=0.2\text{A}$			1.2	V
		$I_C=2\text{A}$, $I_B=0.5\text{A}$			1.6	V
		$I_C=2\text{A}$, $I_B=0.5\text{A}$, $T_C=100^\circ\text{C}$			1.5	V
DYNAMIC CHARACTERISTICS						
Current-Gain-Bandwidth Product	f_T	$I_C=500\text{mA}$, $V_{CE}=10\text{V}$, $f=1\text{MHz}$	4			MHz
Output Capacitance	C_{OB}	$V_{CB}=10\text{V}$, $I_E=0$, $f=0.1\text{MHz}$		65		pF
SWITCHING CHARACTERISTICS						
Resistive Load (Table 1)						
Delay Time	t_D	$V_{CC}=125\text{V}$, $I_C=2\text{A}$, $I_{B1}=I_{B2}=0.4\text{A}$, $t_p=25\mu\text{s}$, Duty Cycles $\leq 1\%$		0.025	0.1	μs
Rise Time	t_R			0.3	0.7	μs
Storage Time	t_S			1.7	4	μs
Fall Time	t_F			0.4	0.9	μs

Note: 1. Pulse Test: Pulse Width=5ms, Duty Cycle $\leq 10\%$

2. Pulse Test: $P_W=300\mu\text{s}$, Duty Cycle $\leq 2\%$

RESISTIVE SWITCHING PERFORMANCE

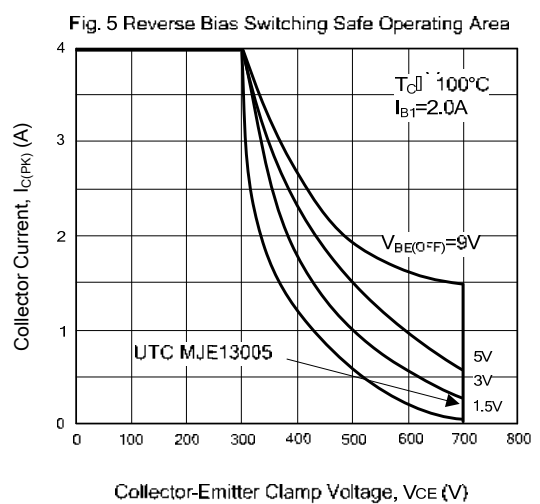
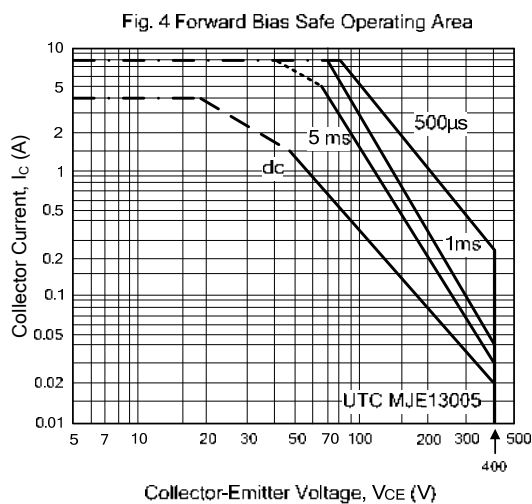
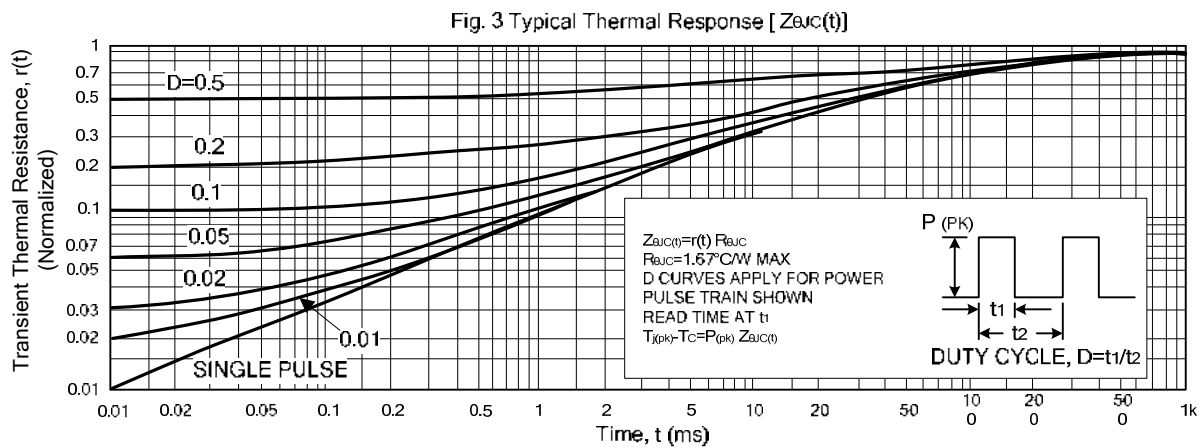
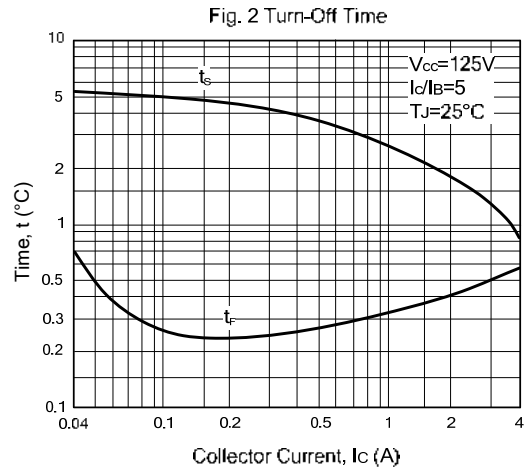
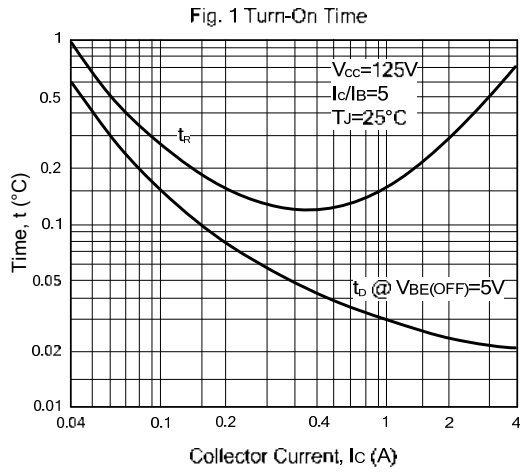

■ RESISTIVE SWITCHING PERFORMANCE(Cont.)

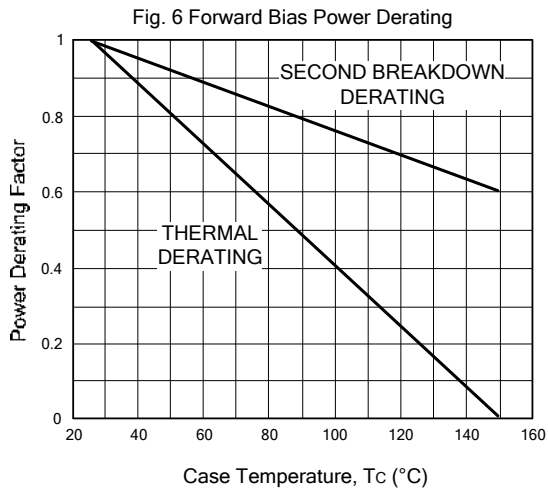

■ TO-220F-3L PACKAGE OUTLINE DIMENSIONS

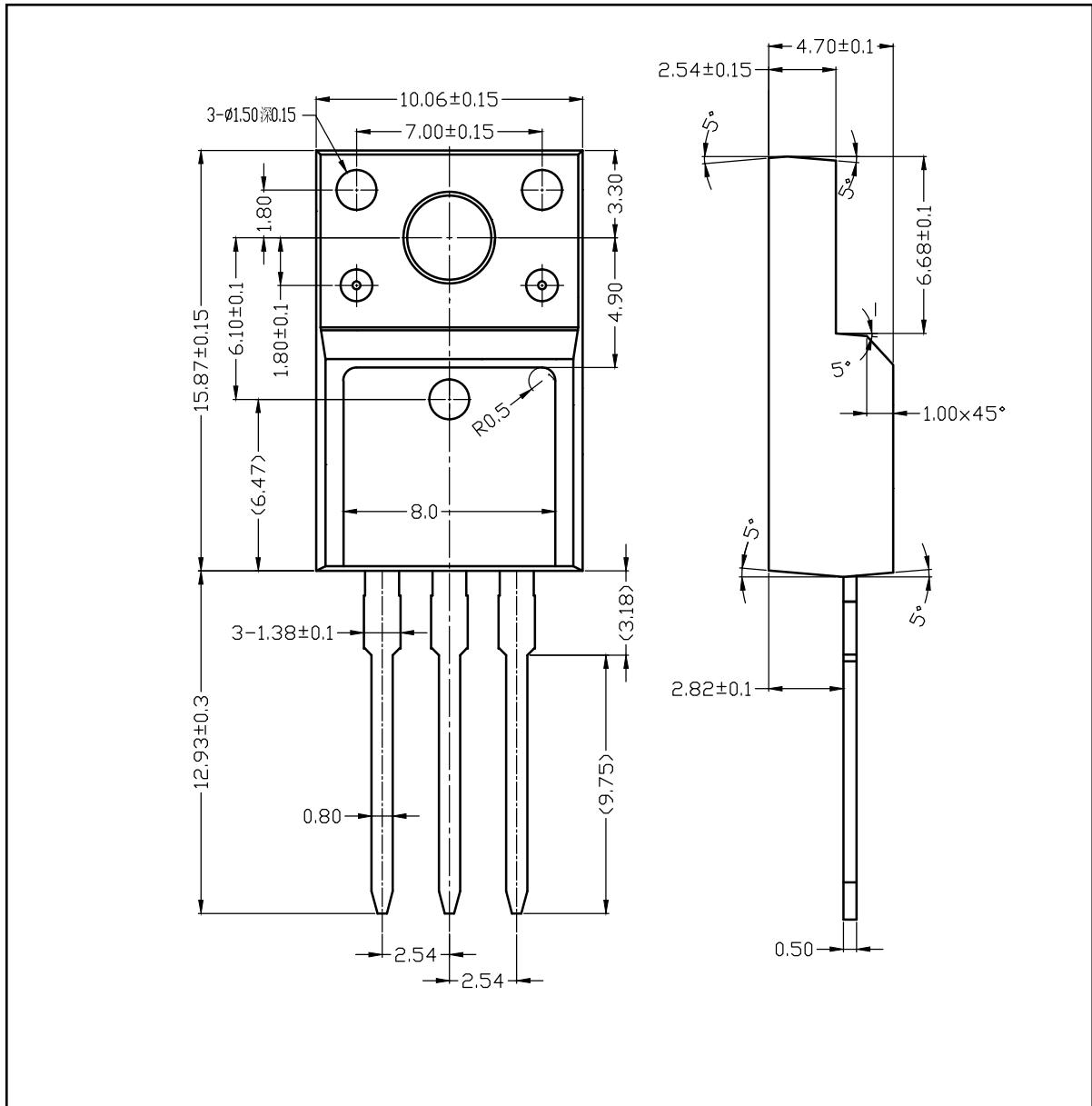

■ TO-220-3L PACKAGE OUTLINE DIMENSIONS

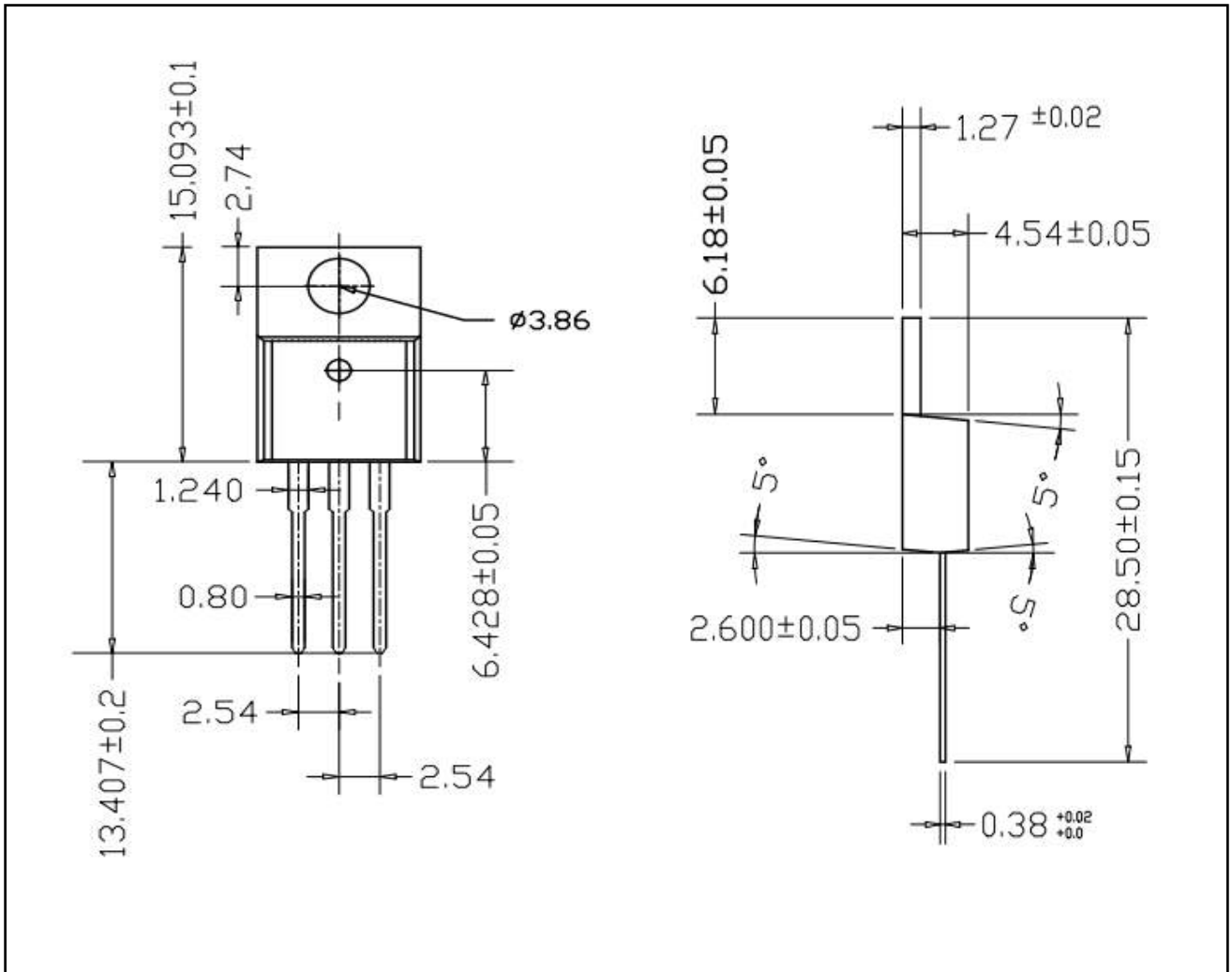

X-ON Electronics

Largest Supplier of Electrical and Electronic Components

Click to view similar products for [Bipolar Transistors - BJT category](#):

Click to view products by [MOT manufacturer](#):

Other Similar products are found below :

[BC559C](#) [MCH4017-TL-H](#) [MMBT-2369-TR](#) [BC546/116](#) [NJVMJD148T4G](#) [NTE16](#) [NTE195A](#) [IMX9T110](#) [2N4401-A](#) [2N6728](#) [2SA1419T-TD-H](#) [2SB1204S-TL-E](#) [2SC5488A-TL-H](#) [FMC5AT148](#) [2N2369ADCSM](#) [2N2907A](#) [2N3904-NS](#) [2N5769](#) [2SC4618TLN](#) [CPH6501-TL-E](#) [US6T6TR](#) [BAX18/A52R](#) [BC556/112](#) [IMZ2AT108](#) [MMST8098T146](#) [MCH6102-TL-E](#) [BC846B-13-F](#) [2N3879](#) [30A02MH-TL-E](#) [NTE13](#) [NTE282](#) [NTE323](#) [NTE350](#) [NTE81](#) [JANTX2N2920L](#) [JANSR2N2907AUB](#) [CMLT3946EG TR](#) [SNSS40600CF8T1G](#) [CMLT3906EG TR](#) [GRP-DATA-JANS2N2907AUB](#) [GRP-DATA-JANS2N2222AUA](#) [MMDT3946FL3-7](#) [2N4240](#) [JANS2N3019](#) [MSB30KH-13](#) [2N2221AUB](#) [2SD1815T-TL-E](#) [2N6678](#) [2N2907Ae4](#) [JAN2N3507](#)