

■ PRODUCT CHARACTERISTICS

VDSS	500V
R _{DS(on)} Typ(@V _{GS} =10 V)	0.22Ω
Qg@type	53nC
ID	20A

■ APPLICATIONS

- * High efficiency switch mode power supplies
- * Electronic lamp ballasts based on half bridge
- * LED power supplies

■ FEATURES

- * High Switching Speed
- * Improved dv/dt capability

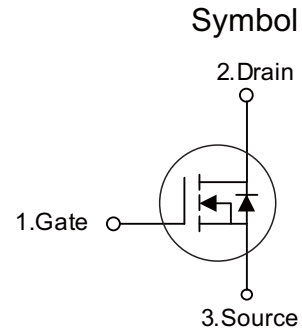

■ ORDER INFORMATION

Order codes		Package	Packing
Halogen-Free	Halogen		
N/A	MOT20N50HF	TO-220F	50 pieces/Tube
N/A	MOT20N50A	TO-220	50 pieces/Tube

■ ABSOLUTE MAXIMUM RATINGS (T_C = 25°C, unless otherwise specified)

PARAMETER	SYMBOL	RATINGS	UNIT
Drain-Source Voltage	V _{DSS}	500	V
Gate-Source Voltage	V _{GSS}	±30	V
Drain Current	Continuous	I _D	20
	Pulsed (Note 2)	I _{DM}	80
Avalanche Energy	Single Pulsed (Note 3)	E _{AS}	1000
Peak Diode Recovery dv/dt	dv/dt	2.2	V/ns
Power Dissipation	TO-220	P _D	200
	TO-220F		43
Junction Temperature	T _J	+150	°C
Storage Temperature	T _{STG}	-55 ~ +150	°C

Notes: 1. Absolute maximum ratings are those values beyond which the device could be permanently damaged.

Absolute maximum ratings are stress ratings only and functional device operation is not implied.

2. Repetitive Rating: Pulse width limited by maximum junction temperature.

3. L = 10mH, I_{AS} = 14A, V_{DD} = 50V, R_G = 25Ω, Starting T_J = 25°C

4. I_{SD} ≤ 20A, di/dt ≤ 200A/μs, V_{DD} ≤ BV_{DSS}, Starting T_J = 25°C

■ THERMAL DATA

PARAMETER	SYMBOL	RATINGS	UNIT
Junction to Ambient	θ _{JA}	62.5	°C/W
Junction to Case	TO-220	0.625	°C/W
	TO-220F	2.9	°C/W

■ ELECTRICAL CHARACTERISTICS ($T_c=25^\circ\text{C}$, unless otherwise noted)

PARAMETER	SYMBOL	TEST CONDITIONS	MIN	TYP	MAX	UNIT
Off characteristics						
Drain-Source Breakdown Voltage	BV_{DSS}	$I_D=250\mu\text{A}$, $V_{GS}=0\text{V}$	500	-	-	V
Drain-Source Leakage Current	I_{DSS}	$V_{DS}=500\text{V}$, $V_{GS}=0\text{V}$	-	-	1	μA
Gate- Source Leakage Current	Forward	I_{GSS}	-	-	+100	nA
	Reverse				-100	nA
On characteristics						
Gate Threshold Voltage	$V_{GS(TH)}$	$V_{DS}=V_{GS}$, $I_D=250\mu\text{A}$	2.0	-	4.0	V
Static Drain-Source On-State Resistance	$R_{DS(ON)}$	$V_{GS}=10\text{V}$, $I_D=10\text{A}$	-	0.22	0.26	Ω
Dynamic characteristics						
Input Capacitance	C_{ISS}	$V_{GS}=0\text{V}$, $V_{DS}=25\text{V}$, $f=1.0\text{MHz}$	-	2450	-	pF
Output Capacitance	C_{OSS}		-	275	-	pF
Reverse Transfer Capacitance	C_{RSS}		-	16.5	-	pF
Switching characteristics						
Total Gate Charge (Note 1)	Q_G	$V_{DS}=100\text{V}$, $V_{GS}=10\text{V}$, $I_D=20\text{A}$ $I_G=1\text{mA}$ (Note1, 2)	-	53	-	nC
Gate to Source Charge	Q_{GS}		-	11	-	nC
Gate to Drain Charge	Q_{GD}		-	13	-	nC
Turn-ON Delay Time (Note 1)	$t_{D(ON)}$	$V_{DS}=100\text{V}$, $V_{GS}=10\text{V}$, $I_D=20\text{A}$, $R_G=25\Omega$ (Note1, 2)	-	32	-	ns
Rise Time	t_R		-	30	-	ns
Turn-OFF Delay Time	$t_{D(OFF)}$		-	162	-	ns
Fall-Time	t_F		-	70	-	ns
Source-drain diode ratings and characteristics						
Maximum Body-Diode Continuous Current	I_S		-	-	20	A
Maximum Body-Diode Pulsed Current	I_{SM}		-	-	80	A
Drain-Source Diode Forward Voltage (Note 1)	V_{SD}	$I_S=20\text{A}$, $V_{GS}=0\text{V}$	-	-	1.4	V
Body Diode Reverse Recovery Time (Note 1)	t_{rr}	$I_S=20\text{A}$, $V_{GS}=0\text{V}$, $V_R=400\text{V}$ $dI_F/dt=100\text{A}/\mu\text{s}$ (Note 1)	-	412	-	ns
Reverse Recovery Charge	Q_{rr}		-	6.5	-	μC

Notes: 1. Pulse Test: Pulse width $\leq 300\mu\text{s}$, Duty cycle $\leq 2\%$.
 2. Essentially independent of operating temperature.

■ TEST CIRCUITS AND WAVEFORMS

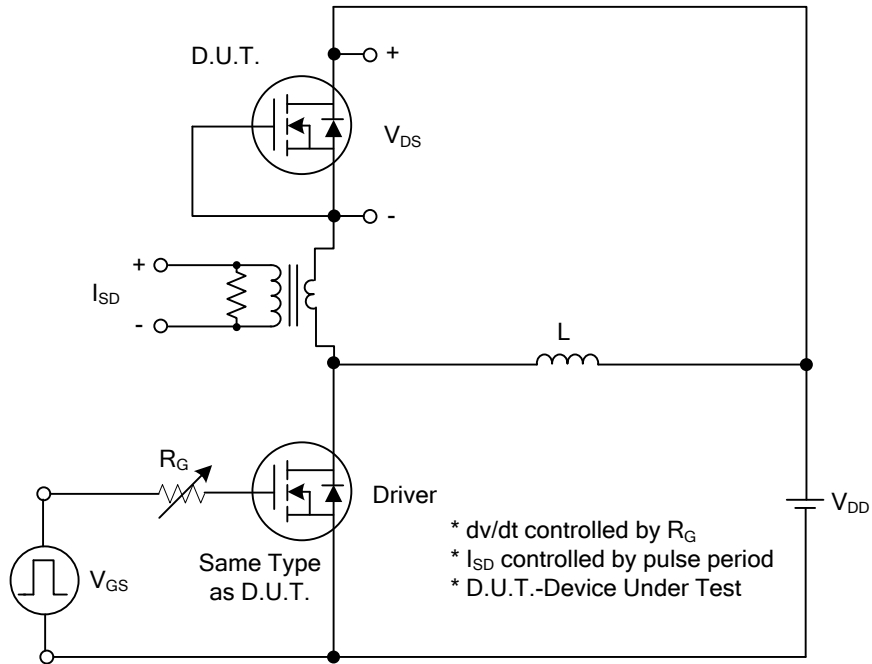

Peak Diode Recovery dv/dt Test Circuit

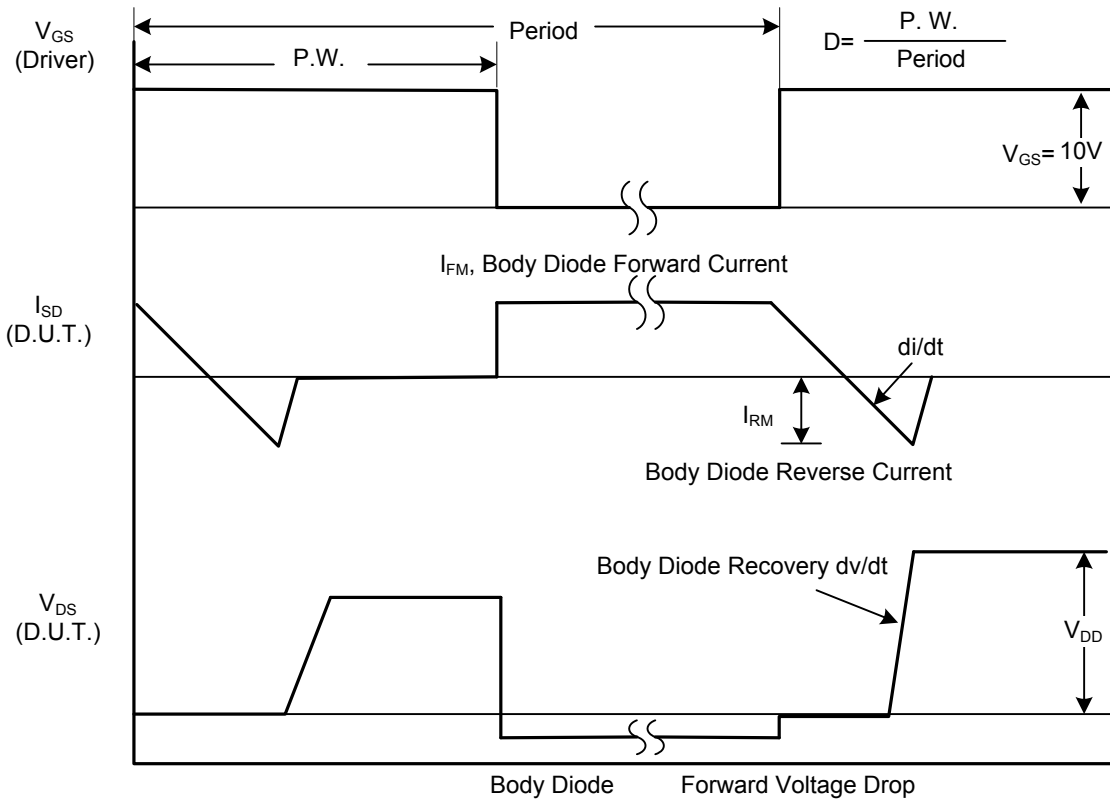

Peak Diode Recovery dv/dt Waveforms

■ TEST CIRCUITS AND WAVEFORMS(Cont.)

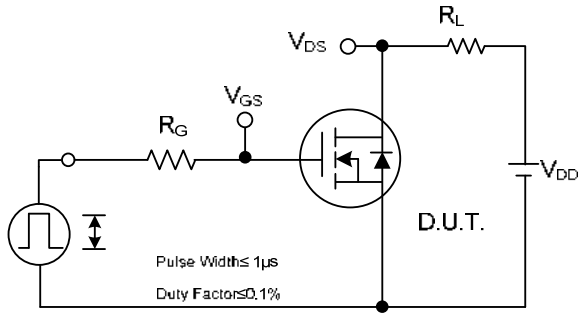

Switching Test Circuit

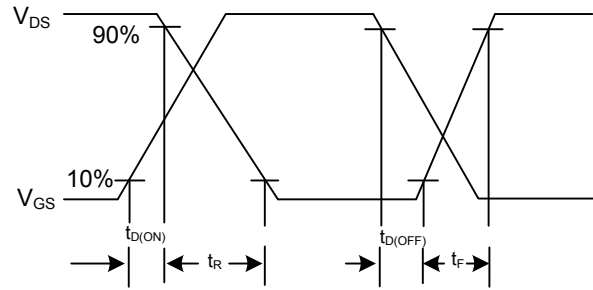

Switching Waveforms

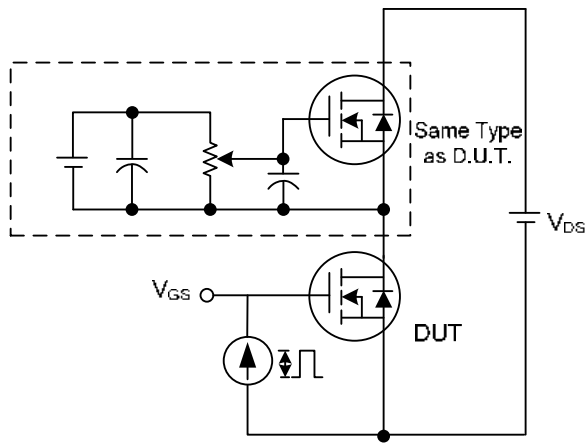

Gate Charge Test Circuit

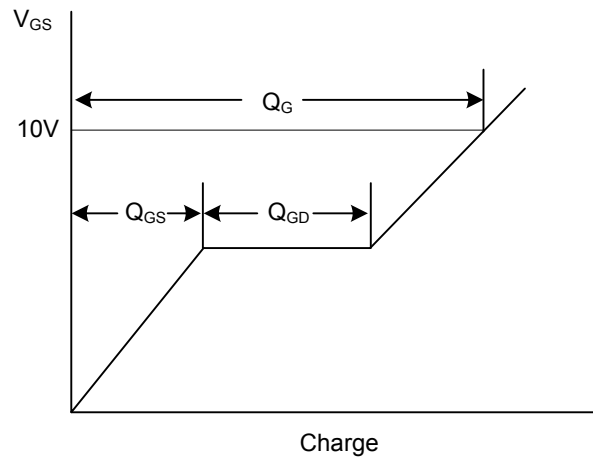

Charge

Gate Charge Waveform

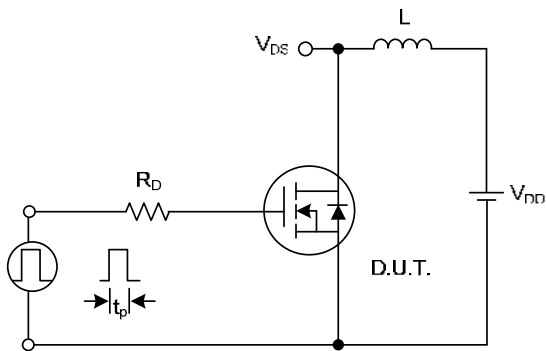

Unclamped Inductive Switching Test Circuit

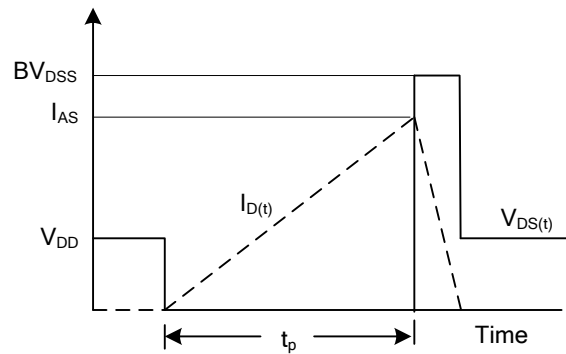

Unclamped Inductive Switching Waveforms

■ TYPICAL CHARACTERISTICS

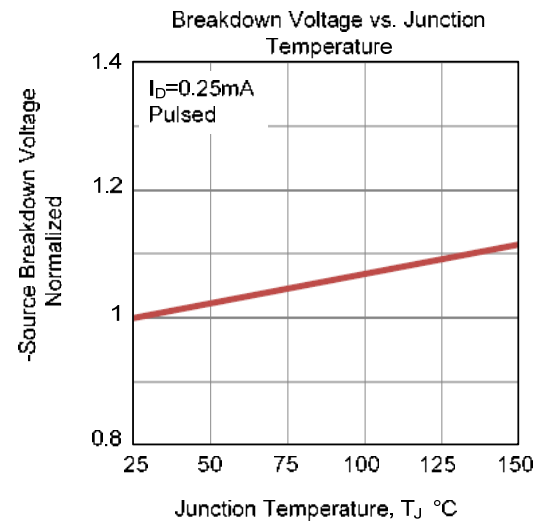
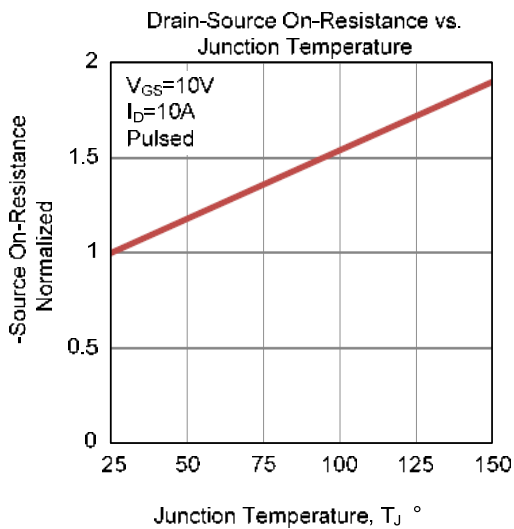
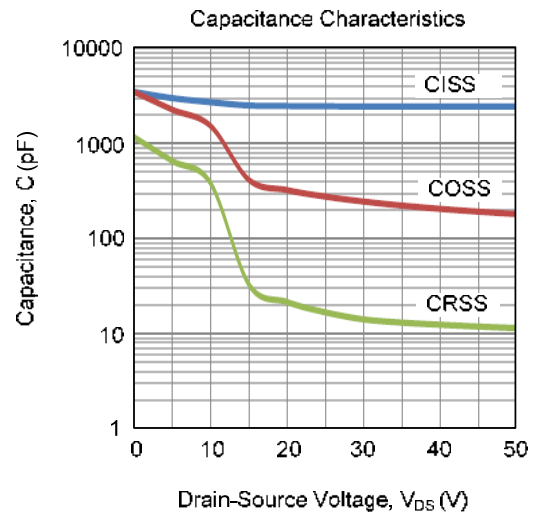
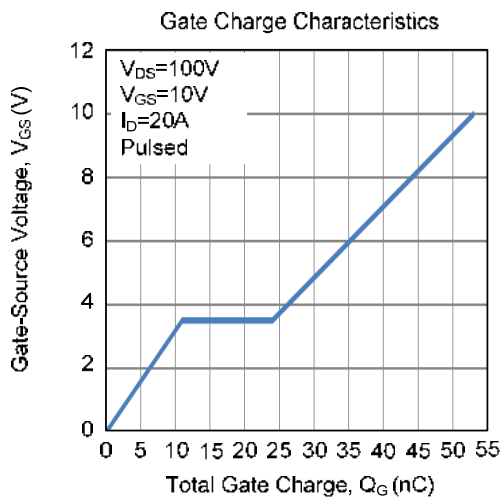
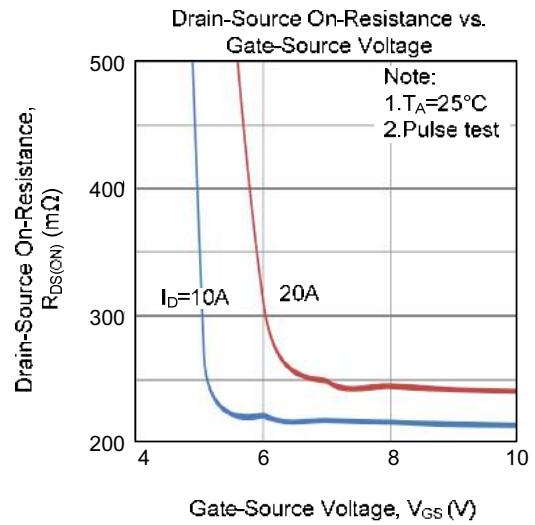
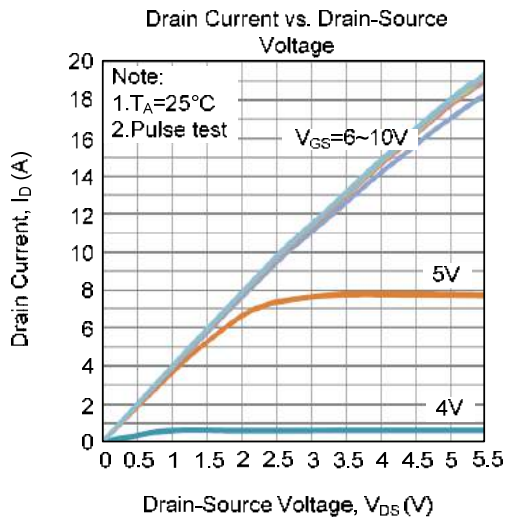

■ TYPICAL CHARACTERISTICS(Cont.)

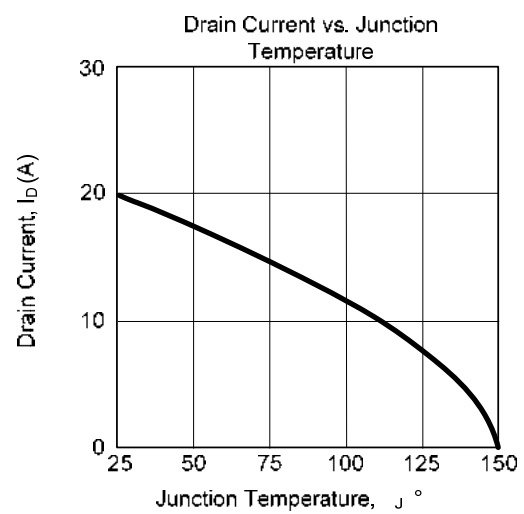
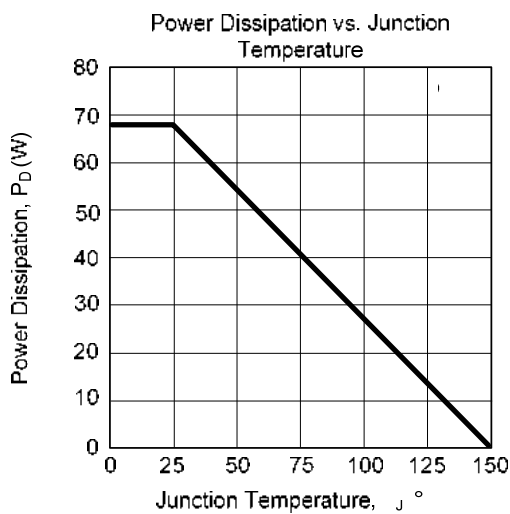
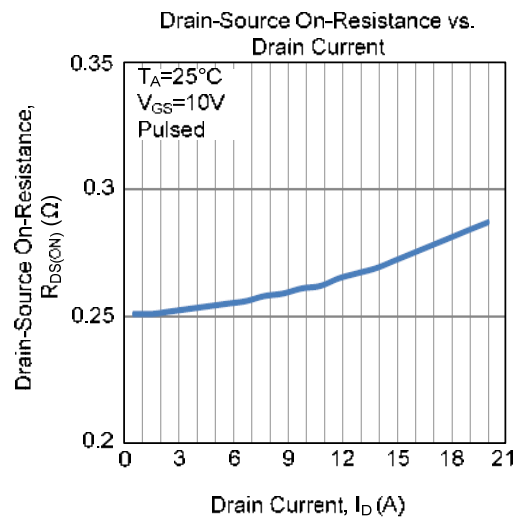
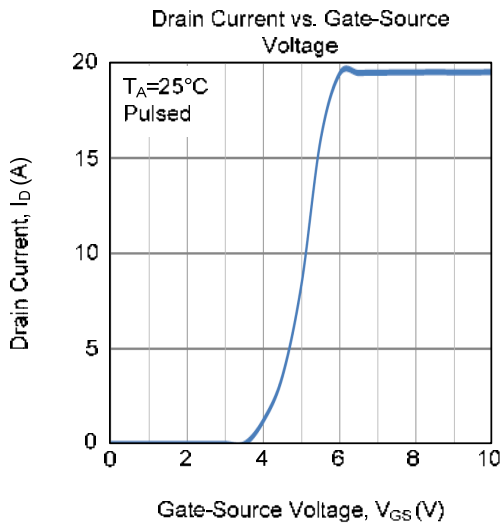
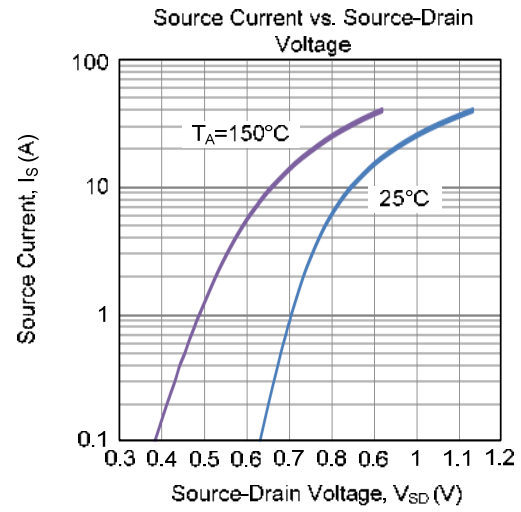
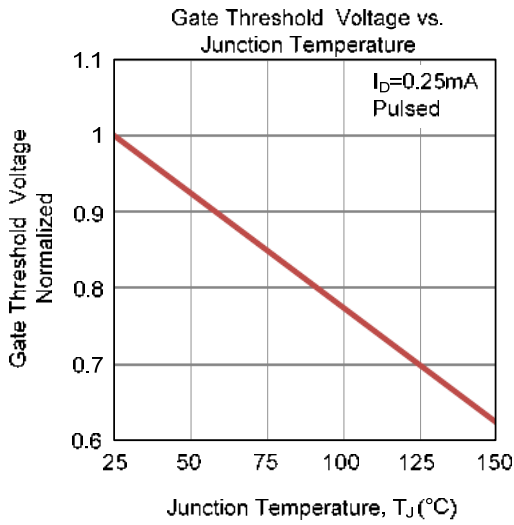

■ TO-220F-3L PACKAGE OUTLINE DIMENSIONS

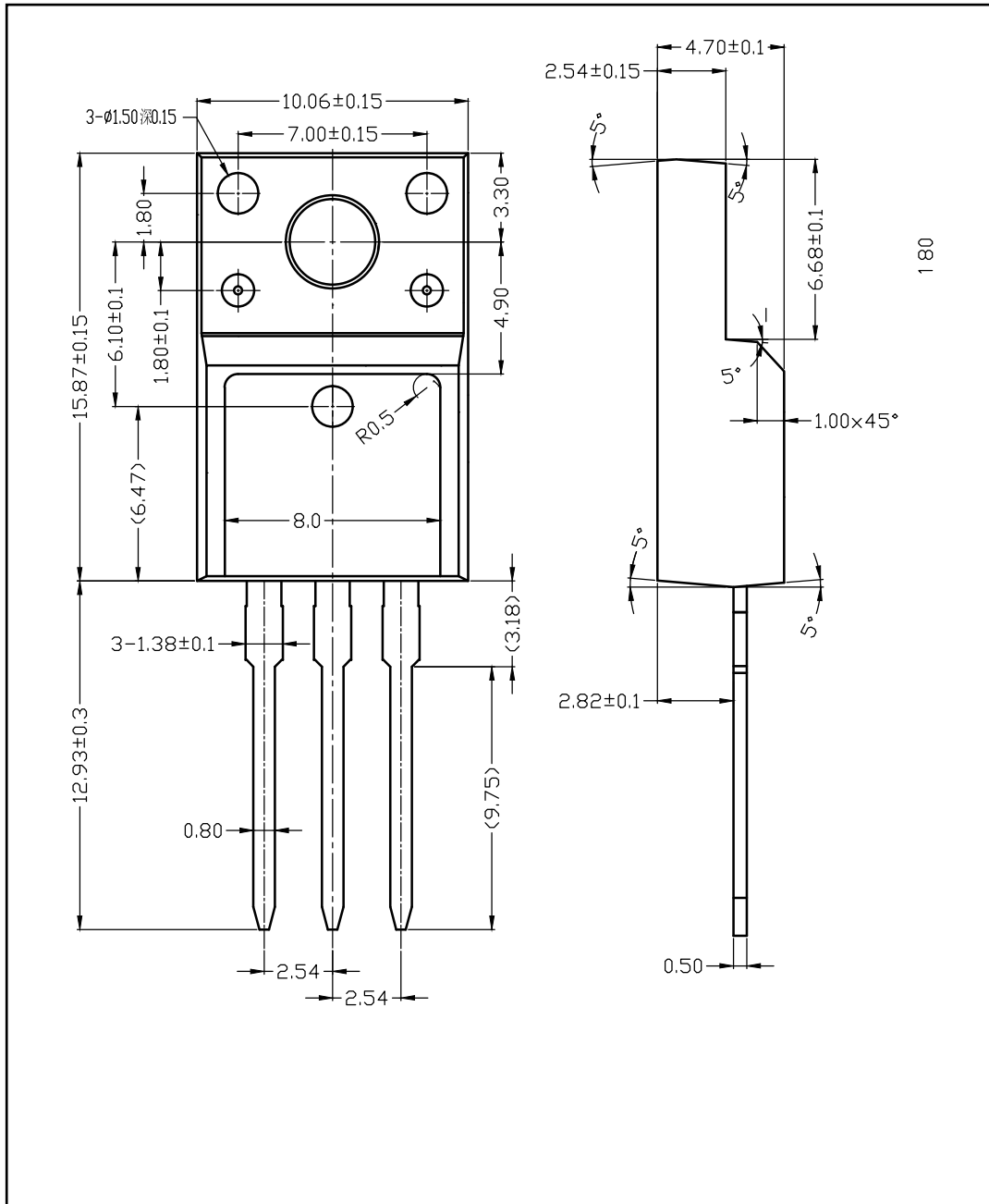

■ TO-220-3L PACKAGE OUTLINE DIMENSIONS

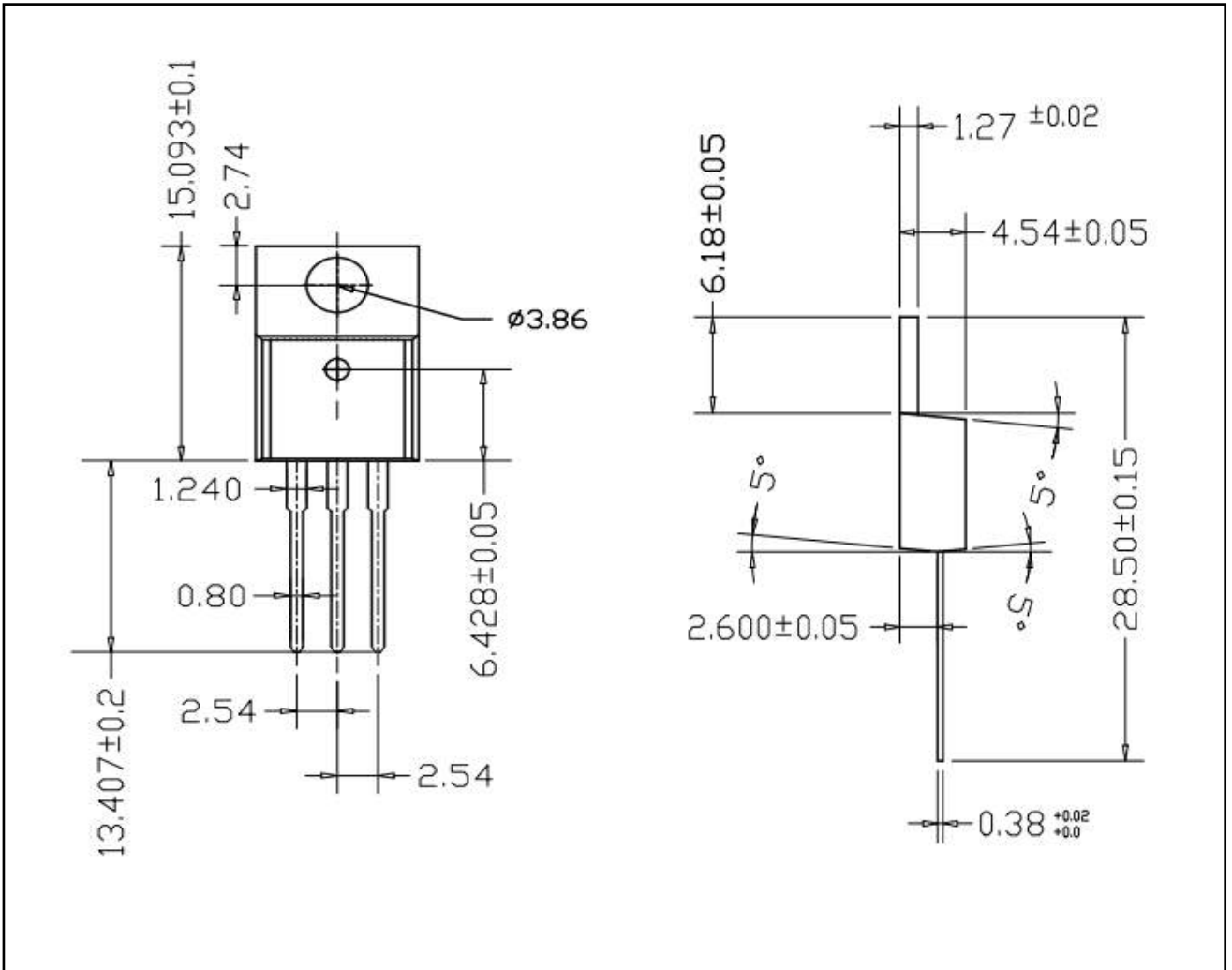

X-ON Electronics

Largest Supplier of Electrical and Electronic Components

Click to view similar products for [MOSFET](#) category:

Click to view products by [MOT](#) manufacturer:

Other Similar products are found below :

[IRFD120](#) [IRFY240C](#) [JANTX2N5237](#) [2SK2267\(Q\)](#) [BUK455-60A/B](#) [MIC4420CM-TR](#) [VN1206L](#) [NDP4060](#) [SI4482DY](#)
[IPS70R2K0CEAKMA1](#) [SQD23N06-31L-GE3](#) [TK16J60W,S1VQ\(O](#) [2SK2614\(TE16L1,Q\)](#) [DMN1017UCP3-7](#) [EFC2J004NUZTDG](#)
[DMN1053UCP4-7](#) [SQJ469EP-T1-GE3](#) [NTE2384](#) [DMC2700UDMQ-7](#) [DMN2080UCB4-7](#) [DMN61D9UWQ-13](#) [US6M2GTR](#)
[DMN31D5UDJ-7](#) [DMP22D4UFO-7B](#) [DMN1006UCA6-7](#) [DMN16M9UCA6-7](#) [STF5N65M6](#) [IRF40H233XTMA1](#) [STU5N65M6](#)
[DMN6022SSD-13](#) [DMN13M9UCA6-7](#) [DMTH10H4M6SPS-13](#) [DMN2990UFB-7B](#) [IPB80P04P405ATMA2](#) [2N7002W-G](#) [MCAC30N06Y-](#)
[TP](#) [MCQ7328-TP](#) [NTMC083NP10M5L](#) [NVMFS2D3P04M8LT1G](#) [BXP7N65D](#) [BXP4N65F](#) [AOL1454G](#) [WMJ80N60C4](#) [BXP2N20L](#)
[BXP2N65D](#) [BXT1150N10J](#) [BXT1700P06M](#) [TSM60NB380CP](#) [ROG](#) [RQ7L055BGTCR](#) [DMNH15H110SK3-13](#)