

■ PRODUCT CHARACTERISTICS

VDSS	30V
R _{DS(on)} Typ(@V _{GS} =10 V)	2.4mΩ
R _{DS(on)} Typ(@V _{GS} =4.5 V)	3.8mΩ
ID	120A

■ APPLICATIONS

- * Power switching application
- * Hard switched and high frequency circuits
- * Uninterruptible power supply

■ FEATURES

- * High density cell design gor ultra low Rdson
- * Excellent package for good heat DISSIPATION

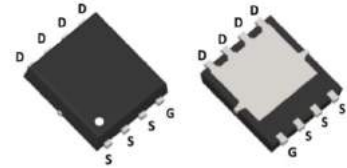
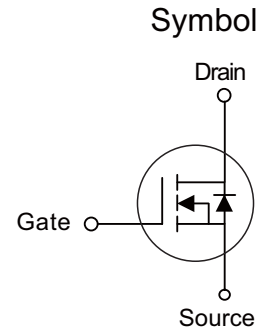

■ ORDER INFORMATION

Order codes		Package	Packing
Halogen-Free	Halogen		
N/A	MOT3136G	PDFN5X6-8L	5000 pieces /Reel

■ ABSOLUTE MAXIMUM RATINGS (T_C = 25°C, unless otherwise specified)

Parameter	Symbol	Value	Unit
Drain-Source Voltage	V _{DS}	30	V
Gate-Source Voltage	V _{GS}	±20	V
Drain Current-Continuous	I _D	120	A
Drain Current-Continuous(T _C =100°C)	I _D (100°C)	84	A
Pulsed Drain Current	I _{DM}	420	A
Maximum Power Dissipation	P _D	120	W
Single pulse avalanche energy	E _{AS}	350	mJ
Thermal Resistance,Junction-to-Case	R _{θJC}	1.25	°C/W
Operating Junction and Storage Temperature Range	T _J , T _{STG}	-55 To 175	°C

■ ELECTRICAL CHARACTERISTICS (T_C=25°C, unless otherwise noted)

Parameter	Symbol	Condition	Min	Typ	Max	Unit
Off characteristics						
Drain-Source Breakdown Voltage	BV _{DSS}	V _{GS} =0V, I _D =250μA	30	-	-	V
Zero Gate Voltage Drain Current	I _{DSS}	V _{DS} =30V, V _{GS} =0V	-	-	1	μA
Gate-Body Leakage Current	I _{GSS}	V _{GS} =±20V, V _{DS} =0V	-	-	±100	nA
On characteristics						
Gate Threshold Voltage	V _{GS(th)}	V _{DS} =V _{GS} , I _D =250μA	1	1.6	3	V
Drain-Source On-State Resistance	R _{DS(ON)}	V _{GS} =10V, I _D =20A	-	2.4	3.6	mΩ
		V _{GS} =4.5V, I _D =20A	-	3.8	4.5	mΩ
Gate resistance	R _G	F=1.0MHz	-	1.5	-	Ω
Forward Transconductance	g _{FS}	V _{DS} =5V, I _D =5A	10	-	-	S
Dynamic characteristics						
Input Capacitance	C _{iss}	V _{DS} =25V, V _{GS} =0V, F=1.0MHz	-	2800	-	PF
Output Capacitance	C _{oss}		-	260	-	PF
Reverse Transfer Capacitance	C _{rss}		-	240	-	PF
Switching characteristics						
Turn-on Delay Time	t _{d(on)}	V _{GS} =10V, V _{DS} =20V R _L =0.75Ω, R _{GEN} =3Ω	-	11	-	nS
Turn-on Rise Time	t _r		-	10	-	nS
Turn-Off Delay Time	t _{d(off)}		-	38	-	nS
Turn-Off Fall Time	t _f		-	11	-	nS
Total Gate Charge	Q _g	V _{GS} =10V, V _{DS} =15V, I _D =20A	-	79	-	nC
Gate-Source Charge	Q _{gs}		-	9	-	nC
Gate-Drain Charge	Q _{gd}		-	18	-	nC
Drain-source diode characteristics						
Diode Forward Voltage	V _{SD}	V _{GS} =0V, I _S =20A	-	-	1.2	V
Diode Forward Current	I _S		-	-	120	A
Reverse Recovery Time	t _{rr}	T _J = 25°C, I _F =20A di/dt = 100A/μs	-	58	-	nS
Reverse Recovery Charge	Q _{rr}		-	115	-	nC

■ TYPICAL CHARACTERISTICS

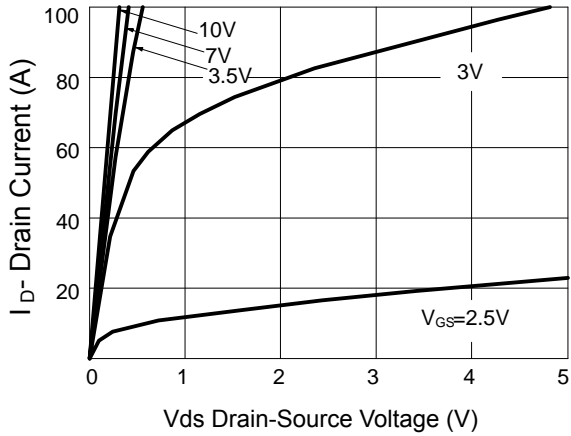

Figure 1: Output characteristics

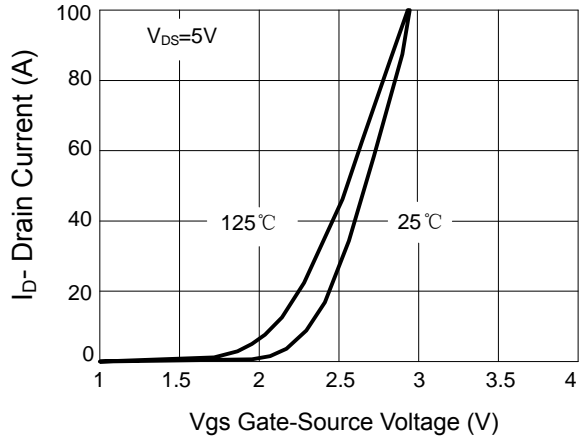

Figure 2: Transfer characteristics

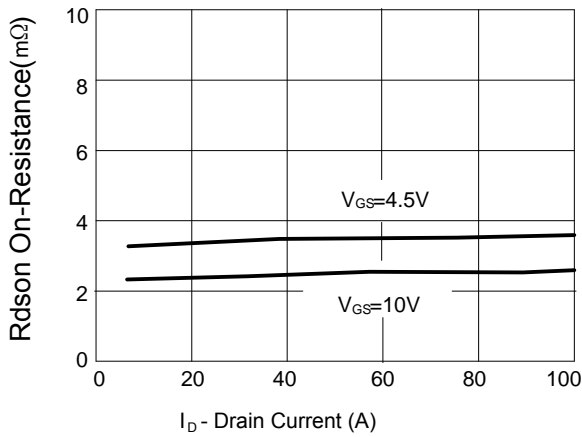

Figure 3: $R_{DS(on)}$ -drain-current

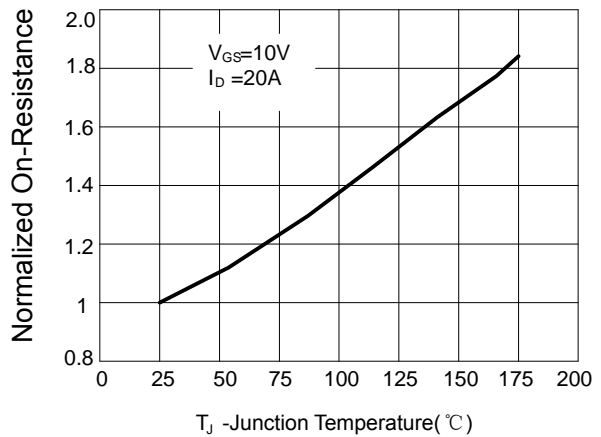

Figure 4: $R_{DS(on)}$ -junction temperature

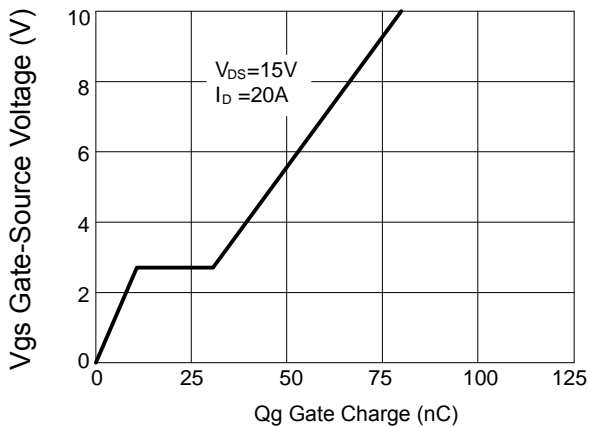

Figure 5: Gate charge

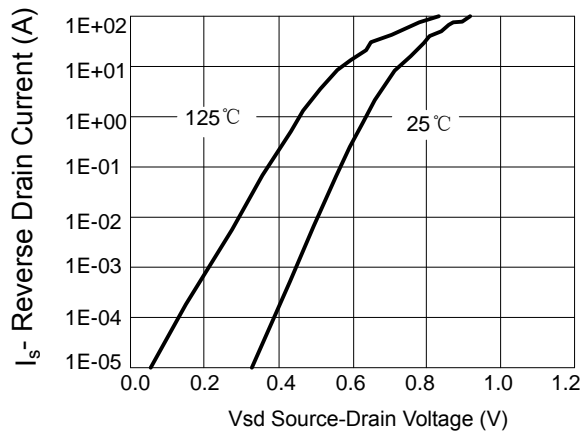

Figure 6: Source-drain diode forward

■ TYPICAL CHARACTERISTICS(Cont,)

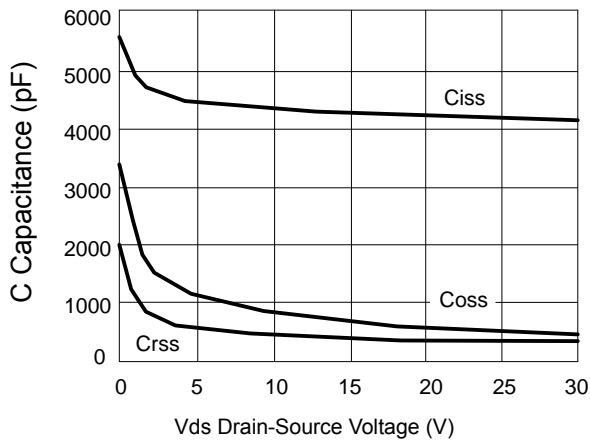

Figure 7:Capacitance vs vds

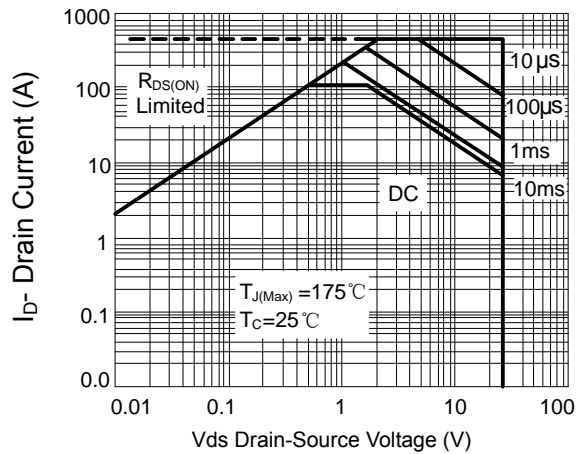

Figure 8:Safe operating area

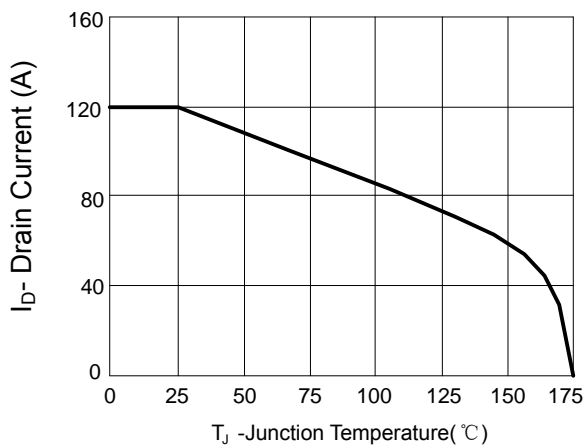

Figure 9:Current de-rating

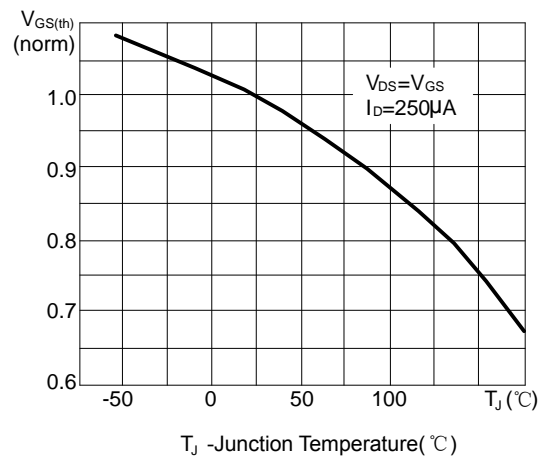
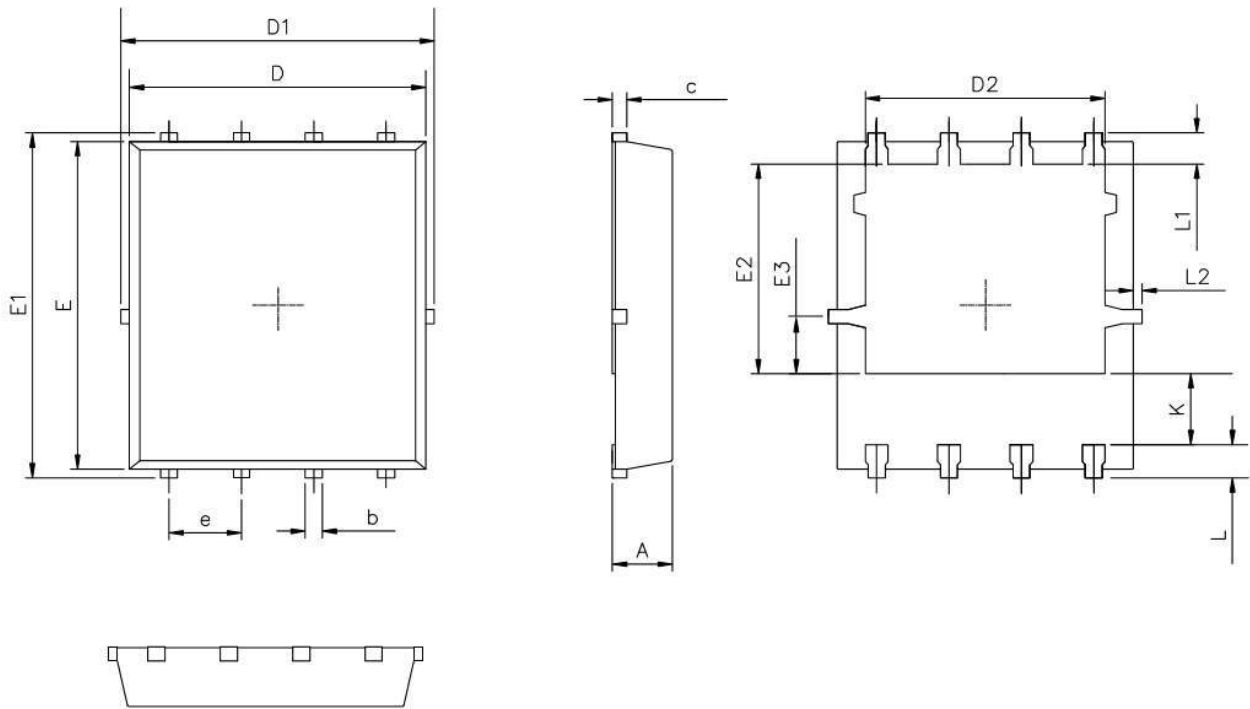
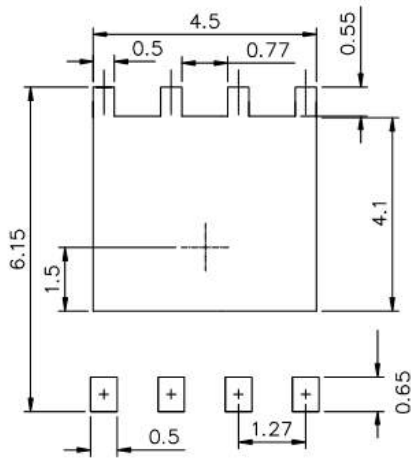

Figure 10:Vgs vs junction temperature

■ PDFN5X6-8L Package Mechanical Data



RECOMMENDED LAND PATTERN



UNIT:mm

	MIN	NOM	MAX
A	0.90	1.00	1.10
b	0.25	0.35	0.50
c	0.10	0.20	0.30
D	4.80	5.00	5.30
D1	4.90	5.10	5.50
D2	3.92	4.02	4.20
E	5.65	5.75	5.85
E1	5.90	6.05	6.20
E2	3.325	3.525	3.775
E3	0.80	0.90	1.00
e		1.27	
L	0.40	0.55	0.70
L1		0.65	
L2	0.00		0.15
K	1.00	1.30	1.50

X-ON Electronics

Largest Supplier of Electrical and Electronic Components

Click to view similar products for [MOSFET](#) category:

Click to view products by [MOT](#) manufacturer:

Other Similar products are found below :

[IRFD120](#) [IRFY240C](#) [JANTX2N5237](#) [2SK2267\(Q\)](#) [BUK455-60A/B](#) [MIC4420CM-TR](#) [VN1206L](#) [NDP4060](#) [SI4482DY](#)
[IPS70R2K0CEAKMA1](#) [SQD23N06-31L-GE3](#) [TK16J60W,S1VQ\(O](#) [2SK2614\(TE16L1,Q\)](#) [DMN1017UCP3-7](#) [EFC2J004NUZTDG](#)
[DMN1053UCP4-7](#) [SQJ469EP-T1-GE3](#) [NTE2384](#) [DMC2700UDMQ-7](#) [DMN2080UCB4-7](#) [DMN61D9UWQ-13](#) [US6M2GTR](#)
[DMN31D5UDJ-7](#) [DMP22D4UFO-7B](#) [DMN1006UCA6-7](#) [DMN16M9UCA6-7](#) [STF5N65M6](#) [IRF40H233XTMA1](#) [STU5N65M6](#)
[DMN6022SSD-13](#) [DMN13M9UCA6-7](#) [DMTH10H4M6SPS-13](#) [DMN2990UFB-7B](#) [IPB80P04P405ATMA2](#) [2N7002W-G](#) [MCAC30N06Y-](#)
[TP](#) [MCQ7328-TP](#) [NTMC083NP10M5L](#) [NVMFS2D3P04M8LT1G](#) [BXP7N65D](#) [BXP4N65F](#) [AOL1454G](#) [WMJ80N60C4](#) [BXP2N20L](#)
[BXP2N65D](#) [BXT1150N10J](#) [BXT1700P06M](#) [TSM60NB380CP](#) [ROG](#) [RQ7L055BGTCR](#) [DMNH15H110SK3-13](#)