

■ PRODUCT CHARACTERISTICS

VDSS	30V
R <sub>DS(on)</sub> typ(@V <sub>GS</sub> =10 V)	3.6mΩ
R <sub>DS(on)</sub> typ(@V <sub>GS</sub> =4.5 V)	5.3mΩ
ID	85A

■ APPLICATIONS

- Portable Equipment and Battery Powered systems.
- Power Management in Notebook Computer

■ FEATURES

- Lower R<sub>DS(ON)</sub> to Minimize Conduction Losses
- Reliable and Rugged
- ROHS Compliant & Halogen-Free
- 100% UIS and Rg Tested

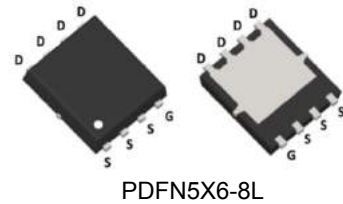
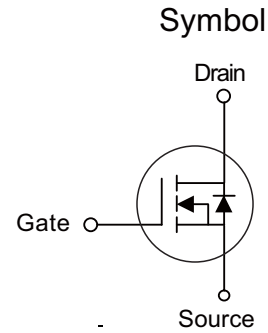

■ ORDER INFORMATION

Order codes		Package	5000pieces/Reel
Halogen-Free	Halogen		
N/A	MOT3145G	PDFN5X6	

■ ABSOLUTE MAXIMUM RATINGS (T<sub>J</sub>=25°C Unless Otherwise Noted)

Parameter	Symbol	Rating	Unit
Drain-Source Voltage	V <sub>DSS</sub>	30	V
Gate-Source Voltage	V <sub>GSS</sub>	±20	V
Maximum Junction Temperature	T <sub>J</sub>	150	°C
Storage Temperature Range	T <sub>STG</sub>	-55 to 150	°C
Pulse Drain Current Tested	T <sub>C</sub> =25°C I <sub>DM</sub> <sup>①</sup>	85	A
Continuous Drain Current	T <sub>C</sub> =25°C I <sub>D</sub>	76	A
	T <sub>C</sub> =100°C I <sub>D</sub>	48	A
Maximum Power Dissipation	T <sub>C</sub> =25°C P <sub>D</sub>	31	W
	T <sub>C</sub> =100°C P <sub>D</sub>	12.5	W
Avalanche Current, Single pulse	L=0.1mH I <sub>AS</sub> <sup>②</sup>	28	A
Avalanche Energy, Single pulse	L=0.1mH E <sub>AS</sub> <sup>②</sup>	39	mJ

■ THERMAL CHARACTERISTICS

Parameter	Symbol	Rating	Unit
Thermal Resistance-Junction to Case	R <sub>θJC</sub>	4	°C/W
Thermal Resistance-Junction to Ambient	R <sub>θJA</sub> <sup>③</sup>	60	°C/W

Note ① : Max. current is limited by bonding wire

Note ② : UIS tested and pulse width are limited by maximum junction temperature 150°C

**■ ELECTRICAL CHARACTERISTICS** ( $T_C=25^\circ\text{C}$  unless otherwise specified)

Parameter	Symbol	Test conditions	Min	Typ	Max	Unit
Static electrical characteristics						
Drain-Source Breakdown Voltage	$BV_{DSS}$	$V_{GS}=0V, I_{DS}=250\mu A$	30	-	-	V
Zero Gate Voltage Drain Current	$I_{DSS}$	$V_{DS}=24V, V_{GS}=0V$	-	-	1	$\mu A$
Gate Threshold Voltage	$V_{GS(th)}$	$V_{DS}=V_{GS}, I_{DS}=250\mu A$	1.1	1.6	2.1	V
Gate Leakage Current	$I_{GSS}$	$V_{GS}=\pm 20V, V_{DS}=0V$	-	-	$\pm 100$	nA
Drain-Source On-state Resistance	$R_{DS(on)}^{④}$	$V_{GS}=10V, I_{DS}=20A$	-	3.6	4.5	m $\Omega$
		$V_{GS}=4.5V, I_{DS}=18A$	-	5.3	7.2	m $\Omega$
Forward Transconductance	$g_{fs}$	$V_{DS}=5V, I_{DS}=20A$	-	22	-	S
Dynamic characteristics <sup>⑤</sup>						
Gate Resistance	$R_G$	$V_{GS}=0V, V_{DS}=0V, \text{Freq.}=1\text{MHz}$	-	2.2	-	$\Omega$
Input Capacitance	$C_{ISS}$	$V_{GS}=0V, V_{DS}=15V,$ $\text{Freq.}=1\text{MHz}$	-	1859	-	pF
Output Capacitance	$C_{OSS}$		-	260	-	pF
Reverse Transfer Capacitance	$C_{RSS}$		-	212	-	pF
Turn-on Delay Time	$t_{d(on)}$		-	9.6	-	nS
Turn-on Rise Time	$t_r$	$V_{GS}=10V, V_{DS}=15V,$ $I_D=1A, R_{GEN}=6\Omega$	-	23.4	-	nS
Turn-off Delay Time	$t_{d(off)}$		-	62.8	-	nS
Turn-off Fall Time	$t_f$		-	23	-	nS
Total Gate Charge	$Q_g$		$V_{GS}=4.5V, V_{DS}=25V, I_D=14A$	-	26	-
Total Gate Charge	$Q_g$	$V_{GS}=10V, V_{DS}=25V,$ $I_D=14A$	-	48	-	nC
Gate-Source Charge	$Q_{gs}$		-	3.4	-	nC
Gate-Drain Charge	$Q_{gd}$		-	14	-	nC
Source-drain characteristics						
Diode Forward Voltage	$V_{SD}^{④}$	$I_{SD}=1A, V_{GS}=0V$	-	0.75	1.1	V
Reverse Recovery Time	$T_{rr}$	$I_F=2A, V_R=0V$ $dI_F/dt=100A/\mu S$	-	18.2	-	nS
Reverse Recovery Charge	$Q_{rr}$		-	9.2	-	nC

 Note ④ : Pulse test (pulse width $\leq 300\mu s$ , duty cycle $\leq 2\%$ ).

Note ⑤ : Guaranteed by design, not subject to production testing.

■ TYPICAL CHARACTERISTICS

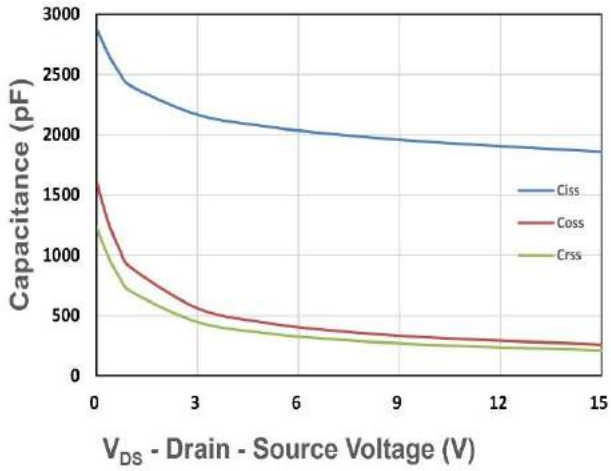

Figure 1. Capacitance

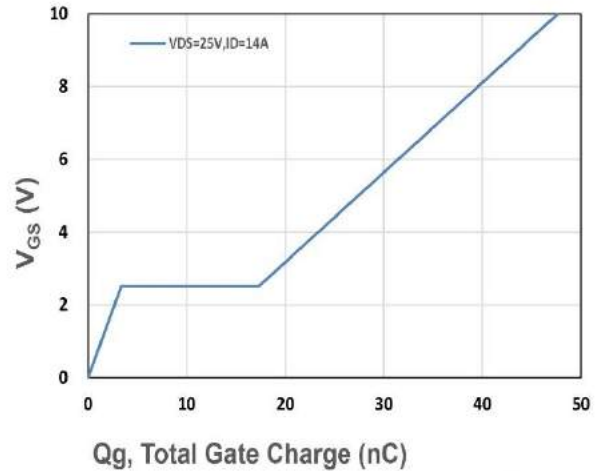

Figure 2. Gate Charge Characteristics

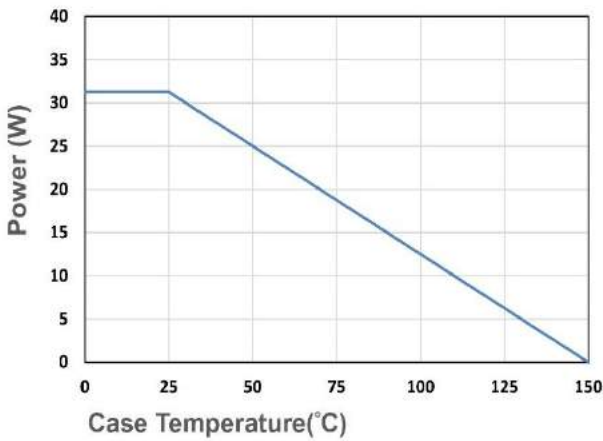

Figure 3. Power Dissipation

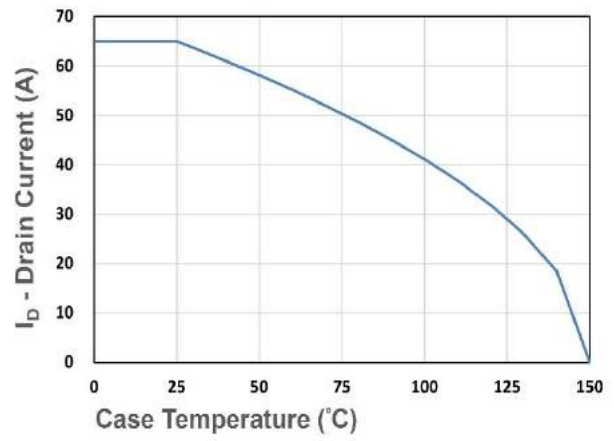

Figure 4. Drain Current

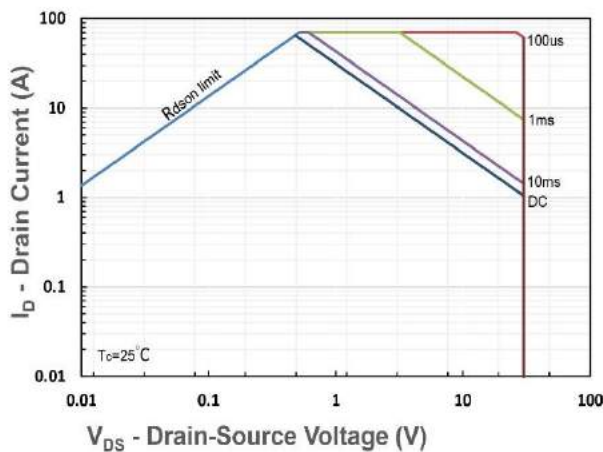

Figure 5. Safe Operating Area

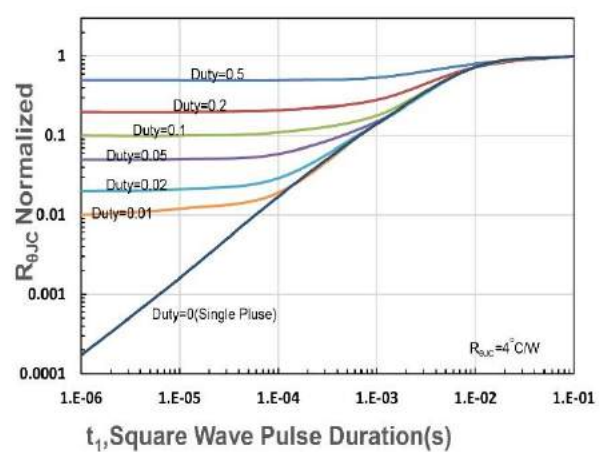
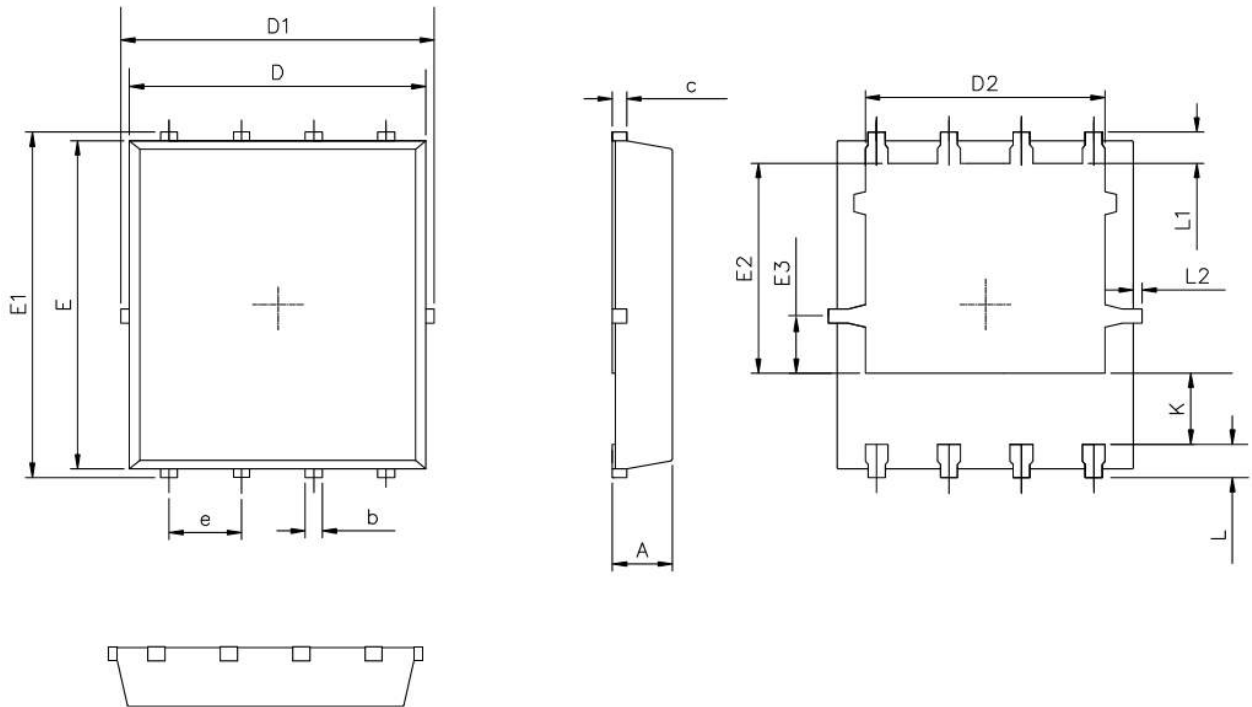
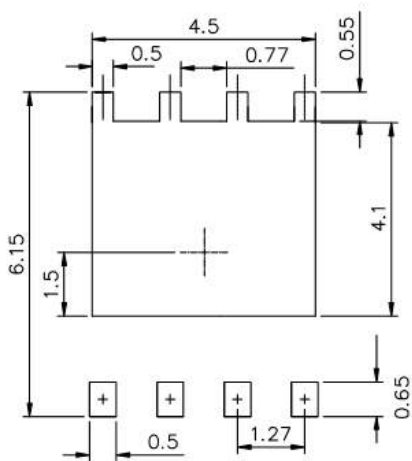

Figure 6.  $R_{\theta JC}$  Transient Thermal Impedance

■ PDFN5X6-8L Package Mechanical Data



RECOMMENDED LAND PATTERN



UNIT:mm

	MIN	NOM	MAX
A	0.90	1.00	1.10
b	0.25	0.35	0.50
c	0.10	0.20	0.30
D	4.80	5.00	5.30
D1	4.90	5.10	5.50
D2	3.92	4.02	4.20
E	5.65	5.75	5.85
E1	5.90	6.05	6.20
E2	3.325	3.525	3.775
E3	0.80	0.90	1.00
e		1.27	
L	0.40	0.55	0.70
L1		0.65	
L2	0.00		0.15
K	1.00	1.30	1.50

## X-ON Electronics

Largest Supplier of Electrical and Electronic Components

*Click to view similar products for [MOSFET](#) category:*

*Click to view products by [MOT](#) manufacturer:*

Other Similar products are found below :

[IRFD120](#) [JANTX2N5237](#) [BUK455-60A/B](#) [MIC4420CM-TR](#) [VN1206L](#) [NDP4060](#) [SI4482DY](#) [IPS70R2K0CEAKMA1](#) [SQD23N06-31L-GE3](#)  
[TK16J60W,S1VQ\(O](#) [2SK2614\(TE16L1,Q\)](#) [DMN1017UCP3-7](#) [DMN1053UCP4-7](#) [SQJ469EP-T1-GE3](#) [NTE2384](#) [DMC2700UDMQ-7](#)  
[DMN2080UCB4-7](#) [DMN61D9UWQ-13](#) [US6M2GTR](#) [DMN31D5UDJ-7](#) [DMP22D4UFO-7B](#) [DMN1006UCA6-7](#) [DMN16M9UCA6-7](#)  
[STF5N65M6](#) [IRF40H233XTMA1](#) [STU5N65M6](#) [DMN6022SSD-13](#) [DMN13M9UCA6-7](#) [DMTH10H4M6SPS-13](#) [DMN2990UFB-7B](#)  
[IPB80P04P405ATMA2](#) [2N7002W-G](#) [MCAC30N06Y-TP](#) [MCQ7328-TP](#) [BXP7N65D](#) [BXP4N65F](#) [AOL1454G](#) [WMJ80N60C4](#) [BXP2N20L](#)  
[BXP2N65D](#) [BXT1150N10J](#) [BXT1700P06M](#) [TSM60NB380CP](#) [ROG](#) [RQ7L055BGTCR](#) [DMNH15H110SK3-13](#) [SLF10N65ABV2](#)  
[BSO203SP](#) [BSO211P](#) [IPA60R230P6](#) [IPA60R460CE](#)