

■ PRODUCT CHARACTERISTICS

VDSS	650V
R <sub>DS(on)</sub> Typ(@V <sub>GS</sub> =10 V)	2.41Ω
Qg@type	19nC
ID	4A

■ APPLICATIONS

- \* High frequency switching mode power supply
- \* Electronic ballast
- \* LED power supplies

■ FEATURES

- \* Fast switching capability
- \* Avalanche energy tested
- \* Improved dv/dt capability, high ruggedness

■ ORDER INFORMATION

Order codes		Package	Packing
Halogen-Free	Halogen		
N/A	MOT4N65D	TO-252	2500 pieces /Reel
N/A	MOT4N65C	TO-251	70 pieces/Tube

Symbol

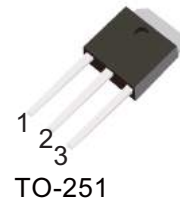
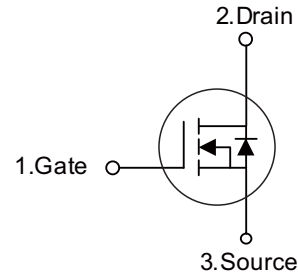

■ ABSOLUTE MAXIMUM RATINGS (T<sub>C</sub> = 25°C, unless otherwise specified)

PARAMETER	SYMBOL	RATINGS	UNIT
Drain-Source Voltage	V <sub>DSS</sub>	650	V
Gate-Source Voltage	V <sub>GSS</sub>	±30	V
Avalanche Current (Note 2)	I <sub>AR</sub>	4.0	A
Drain Current	Continuous	I <sub>D</sub>	4.0
	Pulsed (Note 2)	I <sub>DM</sub>	16
Avalanche Energy	Single Pulsed (Note 3)	E <sub>AS</sub>	260
	Repetitive (Note 2)	E <sub>AR</sub>	10.6
Peak Diode Recovery dv/dt (Note 4)	dv/dt	4.5	V/ns
Power Dissipation	P <sub>D</sub>	50	W
Junction Temperature	T <sub>J</sub>	+150	°C
Operating Temperature	T <sub>OPR</sub>	-55 ~ +150	°C
Storage Temperature	T <sub>STG</sub>	-55 ~ +150	°C

Note: 1. Absolute maximum ratings are those values beyond which the device could be permanently damaged.

Absolute maximum ratings are stress ratings only and functional device operation is not implied.

2. Repetitive Rating : Pulse width limited by maximum junction temperature
3. L = 30mH, I<sub>AS</sub> = 4A, V<sub>DD</sub> = 50V, R<sub>G</sub> = 25 Ω, Starting T<sub>J</sub> = 25°C
4. I<sub>SD</sub> ≤ 4.4A, di/dt ≤ 200A/μs, V<sub>DD</sub> ≤ BV<sub>DSS</sub>, Starting T<sub>J</sub> = 25°C

**■ ELECTRICAL CHARACTERISTICS** ( $T_C=25^\circ\text{C}$ , unless otherwise noted)

PARAMETER	SYMBOL	TEST CONDITIONS	MIN	TYP	MAX	UNIT
Off characteristics						
Drain-Source Breakdown Voltage	$BV_{DSS}$	$V_{GS} = 0V, I_D = 250\mu A$	650	-	-	V
Drain-Source Leakage Current	$I_{DSS}$	$V_{DS} = 650V, V_{GS} = 0V$	-	-	1	$\mu A$
Gate- Source Leakage Current	Forward	$I_{GSS}$	-	-	100	nA
	Reverse				-100	nA
On characteristics						
Gate Threshold Voltage	$V_{GS(TH)}$	$V_{DS} = V_{GS}, I_D = 250\mu A$	2.0	-	4.0	V
Static Drain-Source On-State Resistance	$R_{DS(ON)}$	$V_{GS} = 10V, I_D = 2.0A$	-	2.41	2.8	$\Omega$
Dynamic characteristics						
Input Capacitance	$C_{ISS}$	$V_{DS}=25V, V_{GS}=0V, f=1.0\text{ MHz}$	-	520	-	pF
Output Capacitance	$C_{OSS}$		-	75	-	pF
Reverse Transfer Capacitance	$C_{RSS}$		-	13	-	pF
Switching characteristics						
Total Gate Charge (Note 1)	$Q_G$	$V_{DS}=300V, V_{GS}=10V, I_D=3.0A$ (Note 1, 2)	-	19	-	nC
Gate-Source Charge	$Q_{GS}$		-	3.5	-	nC
Gate-Drain Charge	$Q_{GD}$		-	5.8	-	nC
Turn-On Delay Time (Note 1)	$t_{D(ON)}$	$V_{DD}=50V, V_{GS}=10V, I_D=0.5A,$ $R_G=25\Omega$ (Note 1, 2)	-	9.0	-	ns
Turn-On Rise Time	$t_R$		-	22	-	ns
Turn-Off Delay Time	$t_{D(OFF)}$		-	53	-	ns
Turn-Off Fall Time	$t_F$		-	42	-	ns
Drain-source diode diode characteristics						
Maximum Continuous Drain-Source Diode Forward Current	$I_S$		-	-	4	A
Maximum Pulsed Drain-Source Diode Forward Current	$I_{SM}$		-	-	16	A
Drain-Source Diode Forward Voltage	$V_{SD}$	$I_S=4.0A, V_{GS}=0V$	-	-	1.4	V
Body Diode Reverse Recovery Time	$t_{rr}$	$I_S=4.0A, V_{GS}=0V, di/dt=100A/\mu s$	-	290	-	ns
Body Diode Reverse Recovery Charge	$Q_{rr}$		-	1.65	-	$\mu C$

 Notes: 1. Pulse Test: Pulse width  $\leq 300\mu s$ , Duty cycle  $\leq 2\%$ .

2. Essentially independent of operating temperature.

■ TYPICAL CHARACTERISTICS

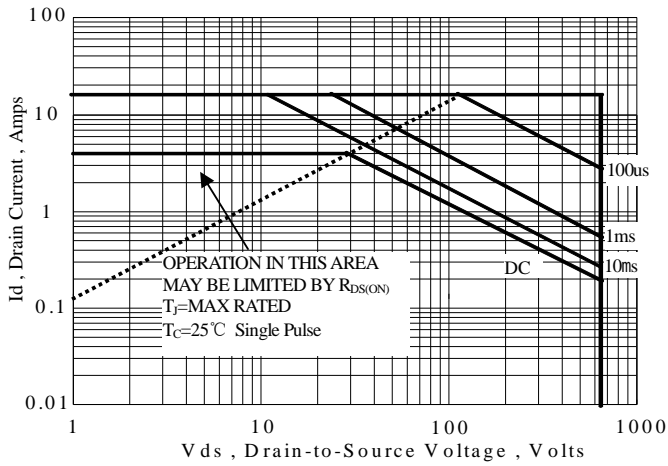

Figure 1 Maximum Forward Bias Safe Operating Area

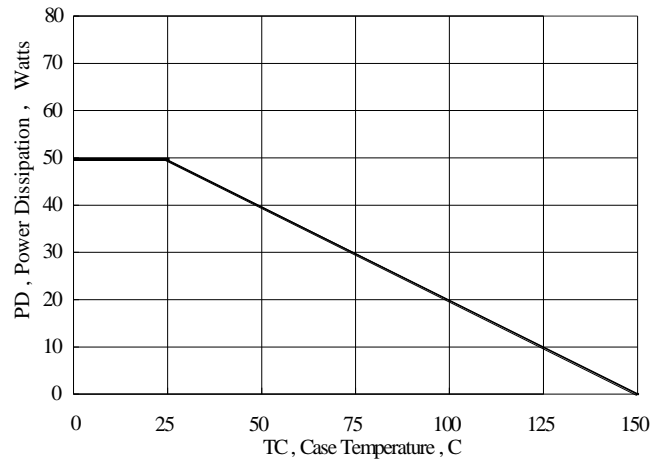

Figure 2 Maximum Power Dissipation vs Case Temperature

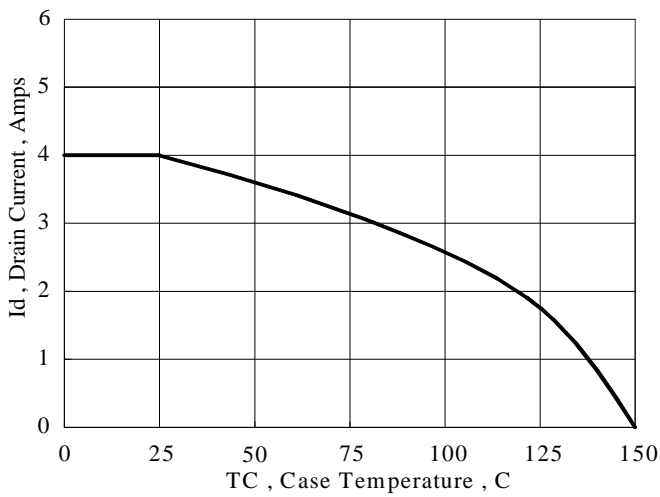

Figure 3 Maximum Continuous Drain Current vs Case Temperature

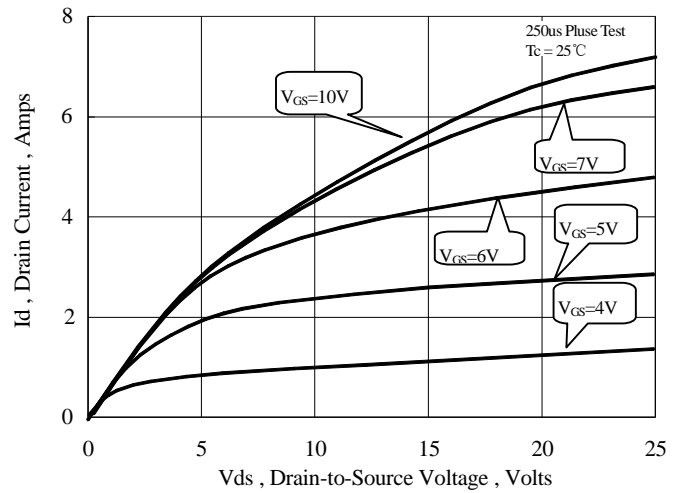

Figure 4 Typical Output Characteristics

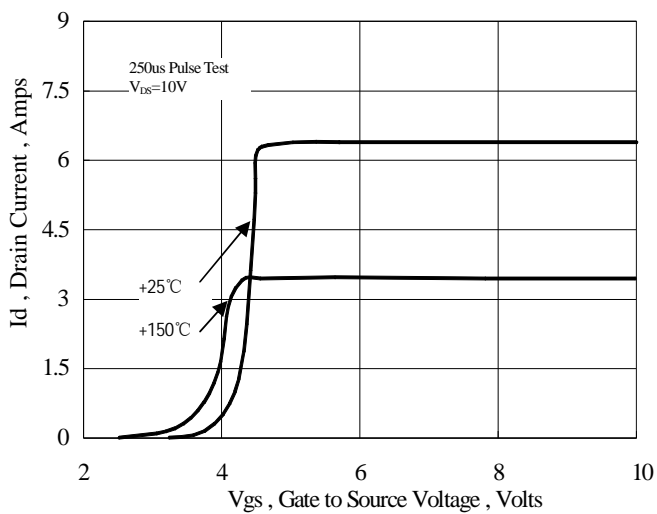

Figure 6 Typical Transfer Characteristics

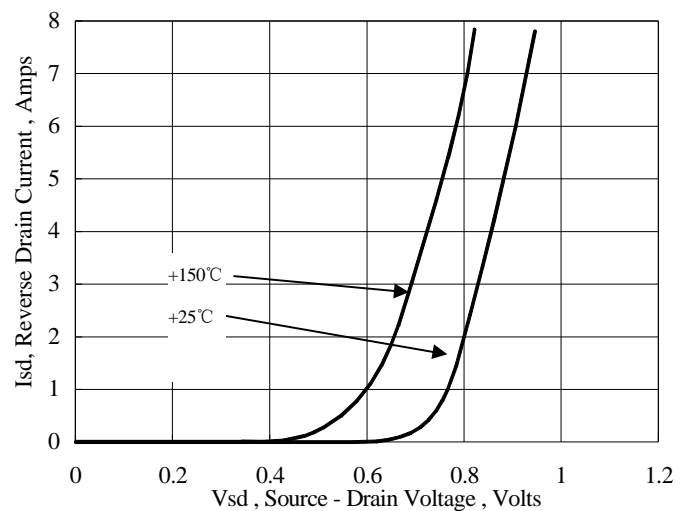

Figure 7 Typical Body Diode Transfer Characteristics

■ TYPICAL CHARACTERISTICS(Cont.)

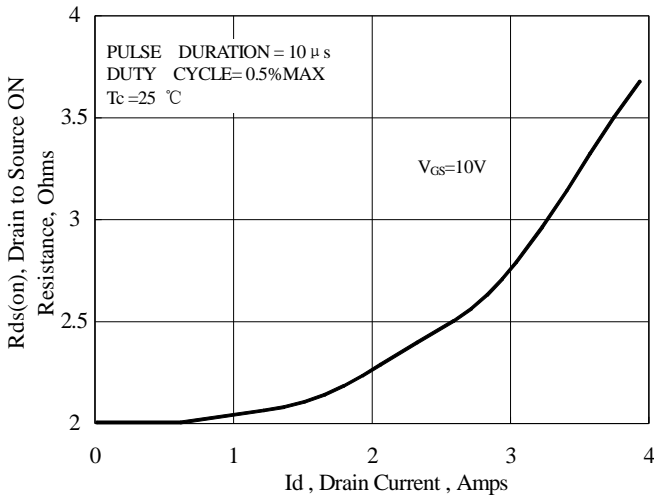

Figure 8 Typical Drain to Source ON Resistance vs Drain Current

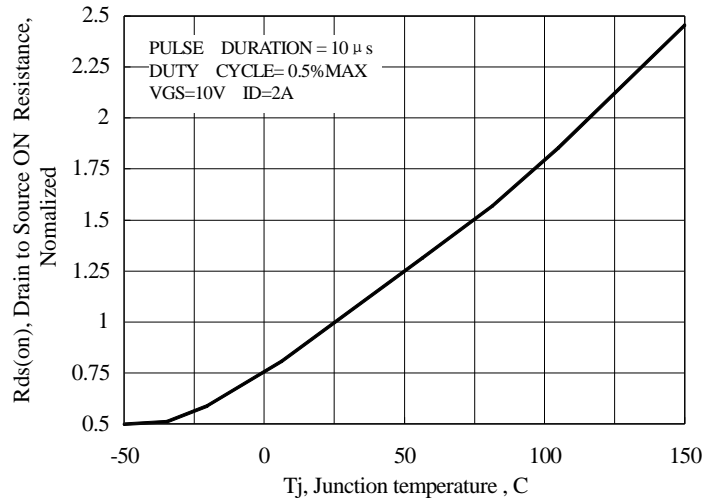

Figure 9 Typical Drain to Source on Resistance vs Junction Temperature

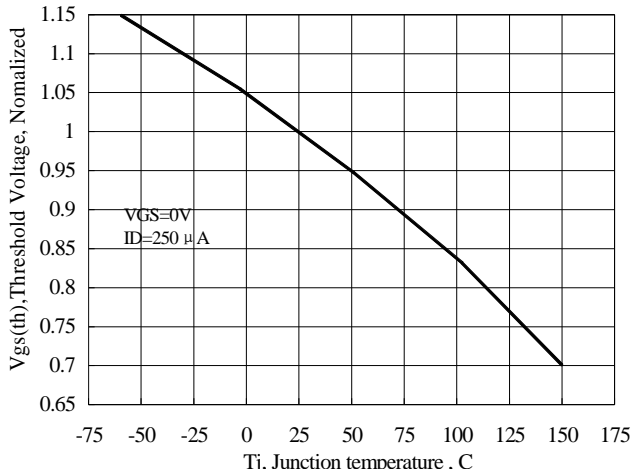

Figure 10 Typical Threshold Voltage vs Junction Temperature

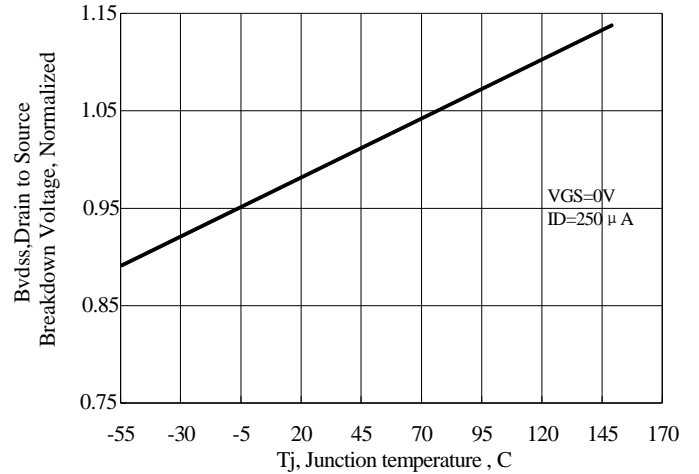

Figure 11 Typical Breakdown Voltage vs Junction Temperature

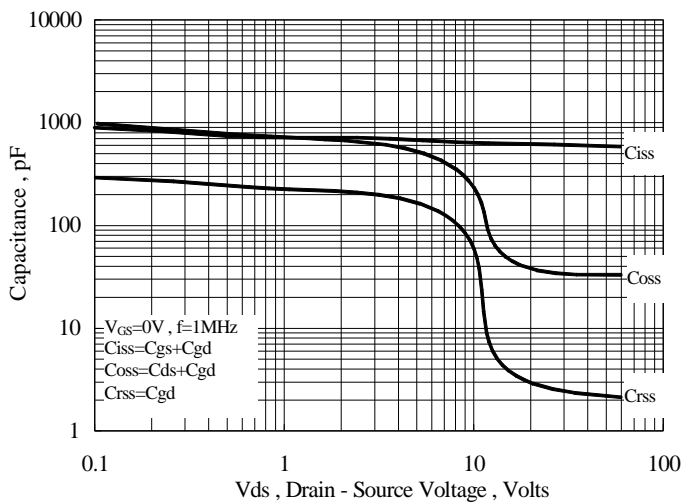

Figure 12 Typical Capacitance vs Drain to Source Voltage

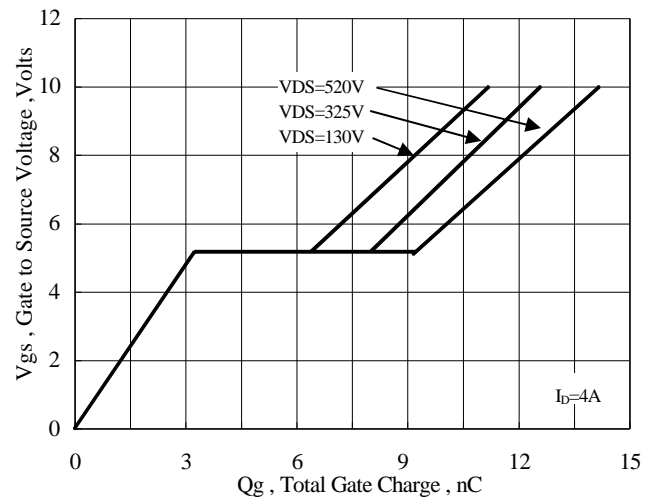
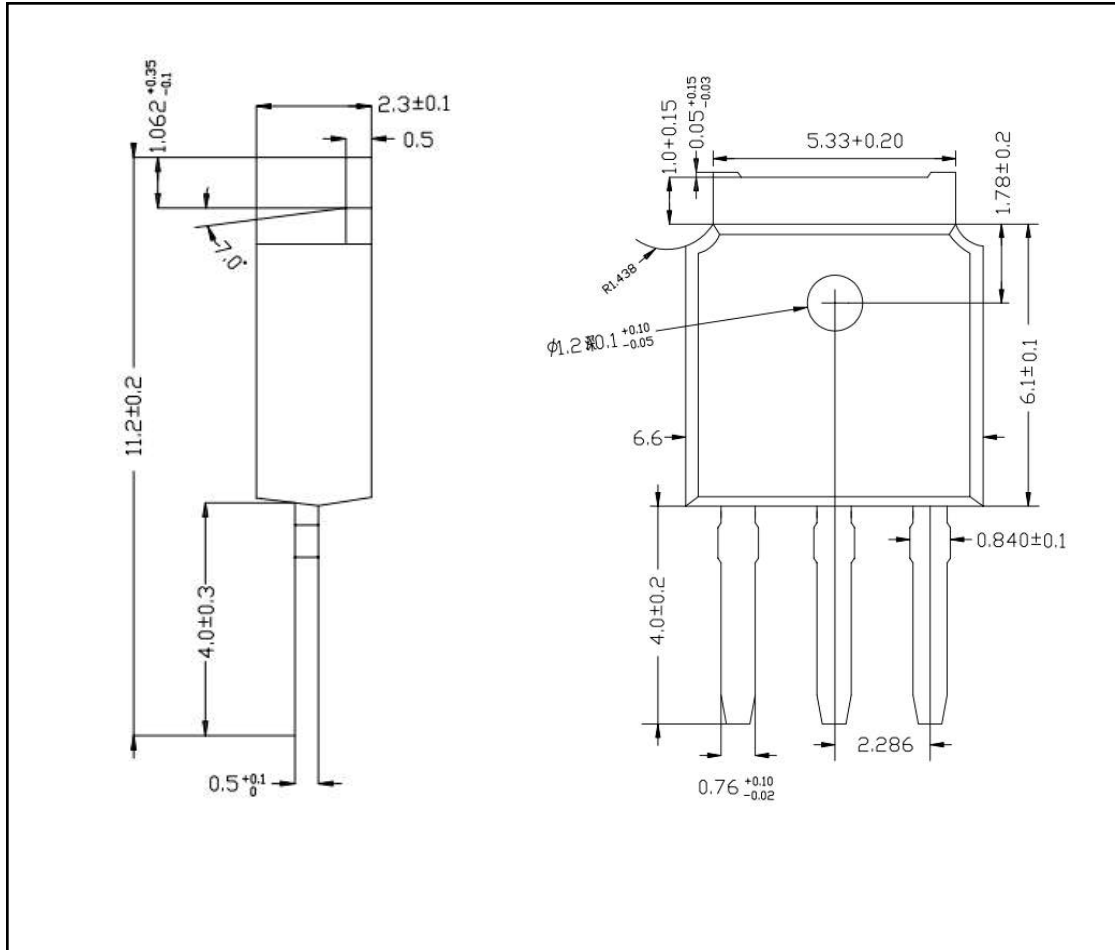
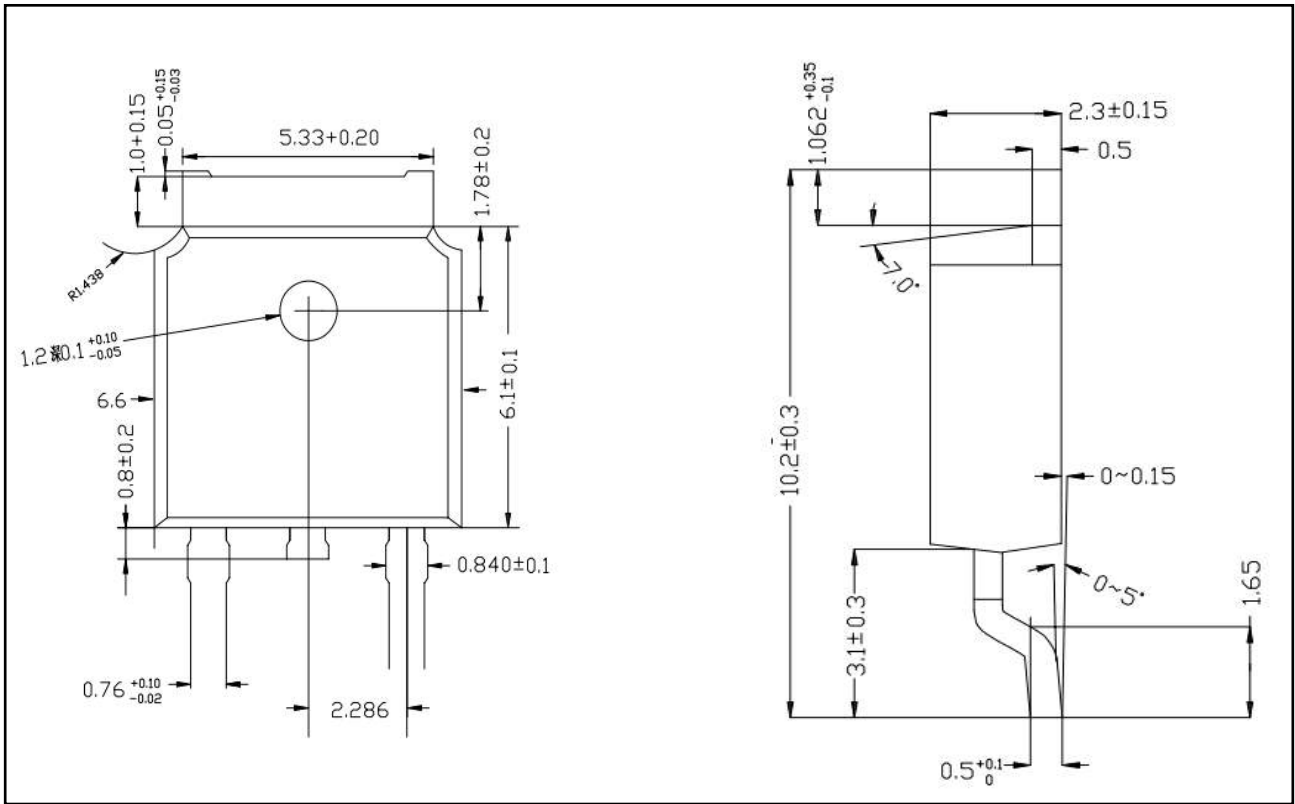

Figure 13 Typical Gate Charge vs Gate to Source Voltage

■ TO-251-3L PACKAGE OUTLINE DIMENSIONS



■ TO-252-2L PACKAGE OUTLINE DIMENSIONS



## X-ON Electronics

Largest Supplier of Electrical and Electronic Components

*Click to view similar products for [MOSFET](#) category:*

*Click to view products by [MOT](#) manufacturer:*

Other Similar products are found below :

[IRFD120](#) [JANTX2N5237](#) [BUK455-60A/B](#) [MIC4420CM-TR](#) [VN1206L](#) [NDP4060](#) [SI4482DY](#) [IPS70R2K0CEAKMA1](#) [SQD23N06-31L-GE3](#)  
[TK16J60W,S1VQ\(O](#) [2SK2614\(TE16L1,Q\)](#) [DMN1017UCP3-7](#) [DMN1053UCP4-7](#) [SQJ469EP-T1-GE3](#) [NTE2384](#) [DMC2700UDMQ-7](#)  
[DMN2080UCB4-7](#) [DMN61D9UWQ-13](#) [US6M2GTR](#) [DMN31D5UDJ-7](#) [DMP22D4UFO-7B](#) [DMN1006UCA6-7](#) [DMN16M9UCA6-7](#)  
[STF5N65M6](#) [IRF40H233XTMA1](#) [STU5N65M6](#) [DMN6022SSD-13](#) [DMN13M9UCA6-7](#) [DMTH10H4M6SPS-13](#) [DMN2990UFB-7B](#)  
[IPB80P04P405ATMA2](#) [2N7002W-G](#) [MCAC30N06Y-TP](#) [MCQ7328-TP](#) [BXP7N65D](#) [BXP4N65F](#) [AOL1454G](#) [WMJ80N60C4](#) [BXP2N20L](#)  
[BXP2N65D](#) [BXT1150N10J](#) [BXT1700P06M](#) [TSM60NB380CP](#) [ROG](#) [RQ7L055BGTCR](#) [DMNH15H110SK3-13](#) [SLF10N65ABV2](#)  
[BSO203SP](#) [BSO211P](#) [IPA60R230P6](#) [IPA60R460CE](#)