

■ PRODUCT CHARACTERISTICS

VDSS	700V
R <sub>DS(on)</sub> Typ(@V <sub>GS</sub> = 10 V)	2.6Ω
Qg@type	15nC
ID	4A

■ APPLICATIONS

- \* High frequency switching mode power supply
- \* Electronic ballast
- \* LED power supplies

■ FEATURES

- \* Ultra Low Gate Charge
- \* Low Reverse Transfer Capacitance
- \* Fast Switching Capability
- \* Avalanche Energy Specified
- \* Improved dv/dt Capability, High Ruggedness

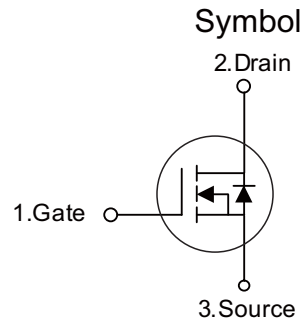

■ ORDER INFORMATION

Order codes		Package	Packing
Halogen-Free	Halogen		
N/A	MOT4N70C	TO-251	70 pieces/Tube
N/A	MOT4N70D	TO-252	2500 pieces/Reel

■ ABSOLUTE MAXIMUM RATINGS (T<sub>A</sub> = 25°C, unless otherwise specified)

PARAMETER	SYMBOL	RATINGS	UNIT
Drain-Source Voltage	V <sub>DSS</sub>	700	V
Gate-Source Voltage	V <sub>GSS</sub>	±30	V
Avalanche Current (Note 2)	I <sub>AR</sub>	4	A
Drain Current	Continuous	I <sub>D</sub>	4
	Pulsed (Note 2)	I <sub>DM</sub>	16
Avalanche Energy	Single Pulsed (Note 3)	E <sub>AS</sub>	260
	Repetitive (Note 2)	E <sub>AR</sub>	10.6
Peak Diode Recovery dv/dt (Note 4)	dv/dt	4.5	V/ns
Power Dissipation	P <sub>D</sub>	49	W
Junction Temperature	T <sub>J</sub>	+150	°C
Operating Temperature	T <sub>OPR</sub>	-55 ~ +150	°C
Storage Temperature	T <sub>STG</sub>	-55 ~ +150	°C

Notes: 1. Absolute maximum ratings are those values beyond which the device could be permanently damaged.

Absolute maximum ratings are stress ratings only and functional device operation is not implied.

2. Repetitive Rating : Pulse width limited by maximum junction temperature

3. L = 26.9mH, I<sub>AS</sub> = 4A, V<sub>DD</sub> = 50V, R<sub>G</sub> = 25 Ω, Starting T<sub>J</sub> = 25°C

4. I<sub>SD</sub> ≤ 4A, di/dt ≤ 200A/μs, V<sub>DD</sub> ≤ BV<sub>DSS</sub>, Starting T<sub>J</sub> = 25°C

**■ ELECTRICAL CHARACTERISTICS** ( $T_A = 25^\circ\text{C}$ , unless otherwise specified)

PARAMETER	SYMBOL	TEST CONDITIONS	MIN	TYP	MAX	UNIT
Off characteristics						
Drain-Source Breakdown Voltage	$BV_{DSS}$	$V_{GS} = 0\text{ V}, I_D = 250\ \mu\text{A}$	700	-	-	V
Drain-Source Leakage Current	$I_{DSS}$	$V_{DS} = 700\text{ V}, V_{GS} = 0\text{ V}$	-	-	10	$\mu\text{A}$
Gate-Source Leakage Current	Forward	$V_{GS} = 30\text{ V}, V_{DS} = 0\text{ V}$ $V_{GS} = -30\text{ V}, V_{DS} = 0\text{ V}$	-	-	100	nA
	Reverse		-	-	-100	
Breakdown Voltage Temperature Coefficient	$\Delta BV_{DSS}/\Delta T_J$	$I_D = 250\ \mu\text{A}$ , Referenced to $25^\circ\text{C}$	-	0.6	-	$\text{V}/^\circ\text{C}$
On characteristics						
Gate Threshold Voltage	$V_{GS(TH)}$	$V_{DS} = V_{GS}, I_D = 250\ \mu\text{A}$	2.0	-	4.0	V
Static Drain-Source On-State Resistance	$R_{DS(ON)}$	$V_{GS} = 10\text{ V}, I_D = 2\text{ A}$	-	2.6	2.8	$\Omega$
Dynamic characteristics						
Input Capacitance	$C_{ISS}$	$V_{DS} = 25\text{ V}, V_{GS} = 0\text{ V},$ $f = 1\text{ MHz}$	-	520	-	pF
Output Capacitance	$C_{OSS}$		-	70	-	pF
Reverse Transfer Capacitance	$C_{RSS}$		-	8	-	pF
Switching characteristics						
Turn-On Delay Time	$t_{D(ON)}$	$V_{DD} = 350\text{ V}, I_D = 4\text{ A},$ $R_G = 25\ \Omega$ (Note 1, 2)	-	13	-	ns
Turn-On Rise Time	$t_R$		-	45	-	ns
Turn-Off Delay Time	$t_{D(OFF)}$		-	25	-	ns
Turn-Off Fall Time	$t_F$		-	35	-	ns
Total Gate Charge	$Q_G$	$V_{DS} = 560\text{ V}, I_D = 4\text{ A},$ $V_{GS} = 10\text{ V}$ (Note 1, 2)	-	15	-	nC
Gate-Source Charge	$Q_{GS}$		-	3.4	-	nC
Gate-Drain Charge	$Q_{GD}$		-	7.1	-	nC
Source-drain diode ratings and characteristics						
Drain-Source Diode Forward Voltage	$V_{SD}$	$V_{GS} = 0\text{ V}, I_S = 4\text{ A}$	-	-	1.4	V
Maximum Continuous Drain-Source Diode Forward Current	$I_S$		-	-	4	A
Maximum Pulsed Drain-Source Diode Forward Current	$I_{SM}$		-	-	16	A
Reverse Recovery Time	$t_{rr}$	$V_{GS} = 0\text{ V}, I_S = 4\text{ A},$	-	250	-	ns
Reverse Recovery Charge	$Q_{RR}$	$di/dt = 100\text{ A}/\mu\text{s}$ (Note 1)	-	1.5	-	$\mu\text{C}$

 Notes: 1. Pulse Test: Pulse width  $\leq 300\ \mu\text{s}$ , Duty cycle  $\leq 2\%$ 

2. Essentially independent of operating temperature

■ TEST CIRCUITS AND WAVEFORMS

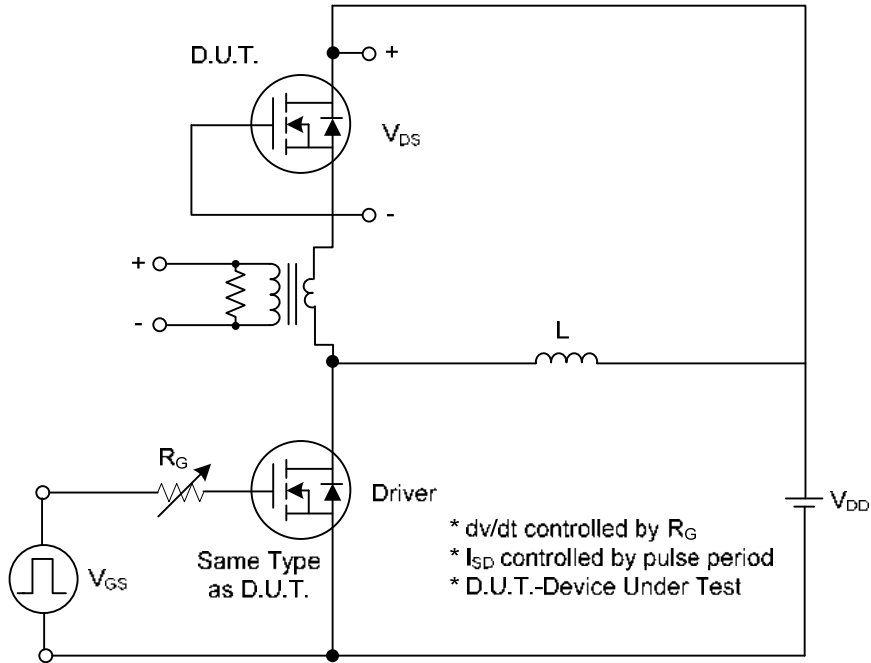

Peak Diode Recovery dv/dt Test Circuit

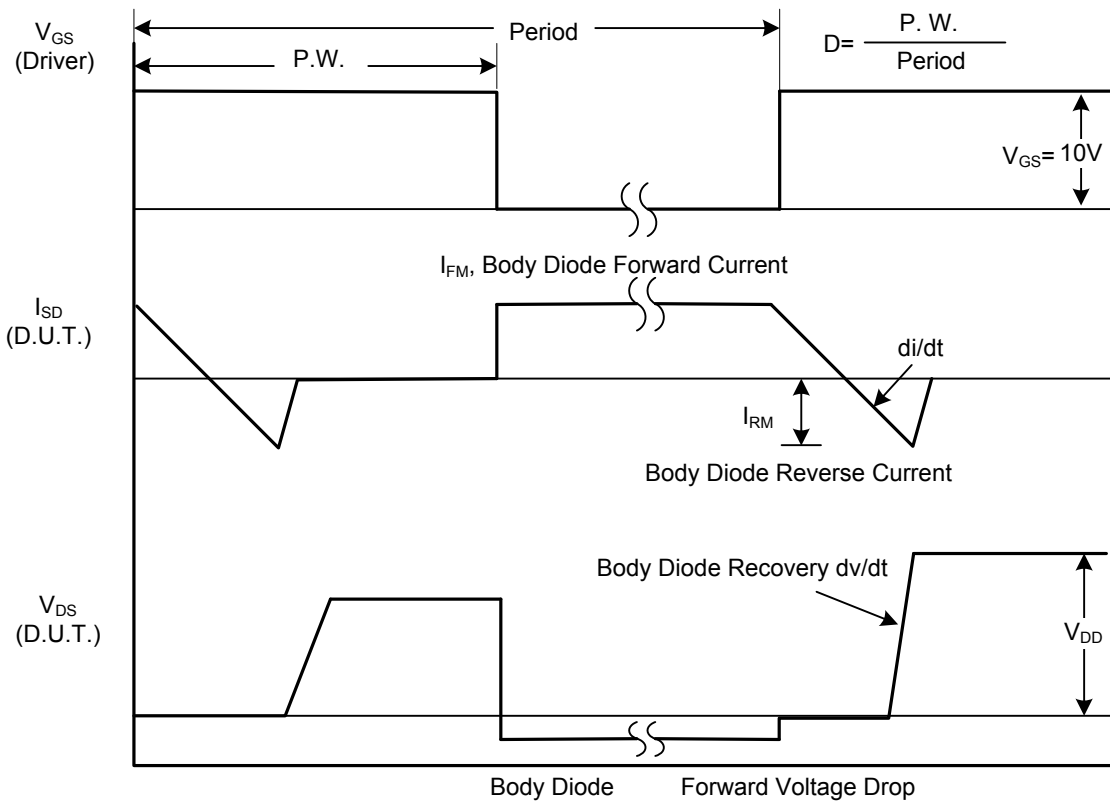

Peak Diode Recovery dv/dt Waveforms

■ TEST CIRCUITS AND WAVEFORMS(Cont.)

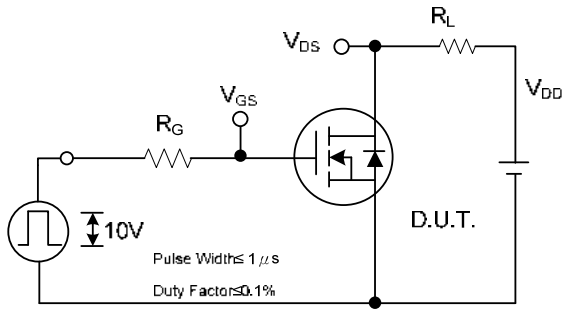

Switching Test Circuit

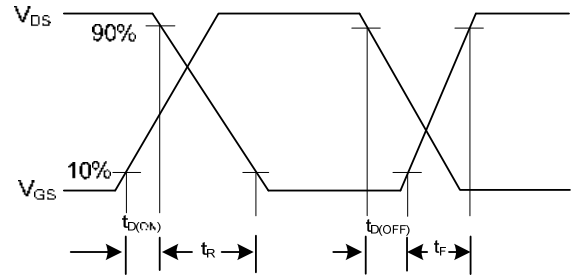

Switching Waveforms

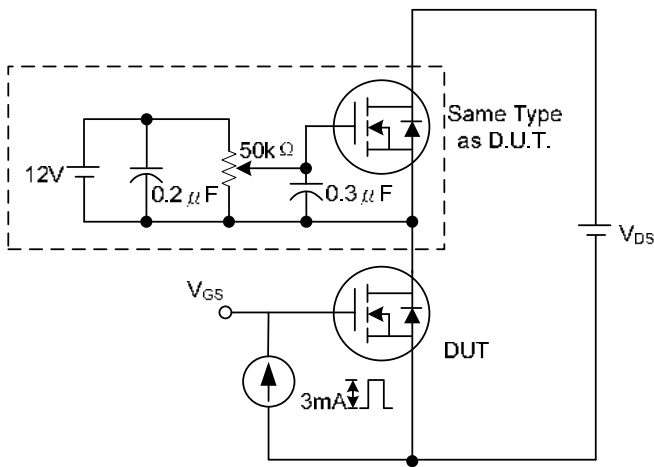

Gate Charge Test Circuit

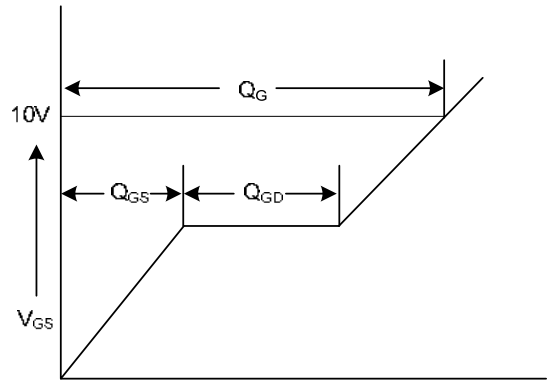

Gate Charge Waveform

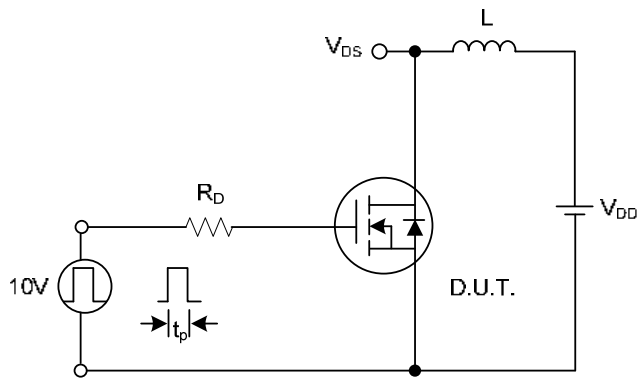

Unclamped Inductive Switching Test Circuit

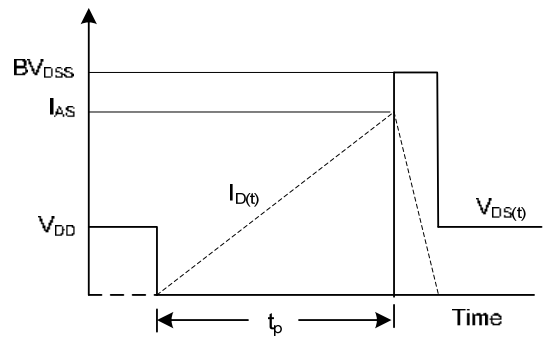

Unclamped Inductive Switching Waveforms

■ TYPICAL CHARACTERISTICS

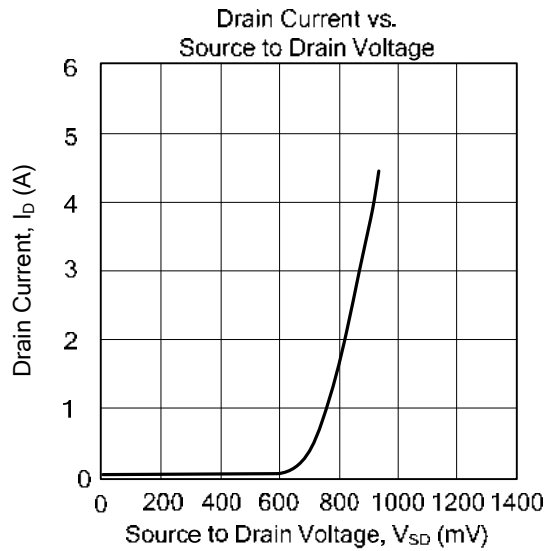
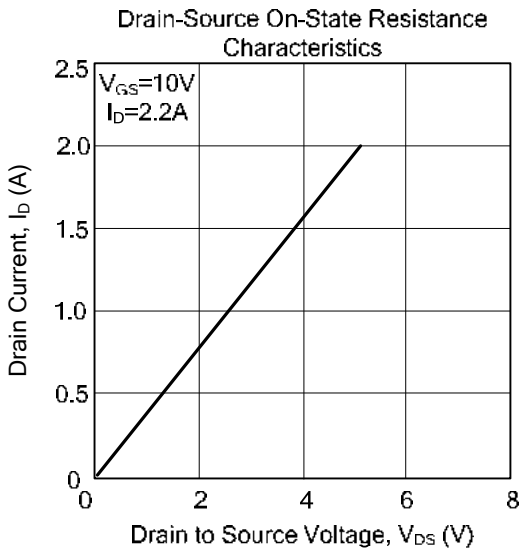
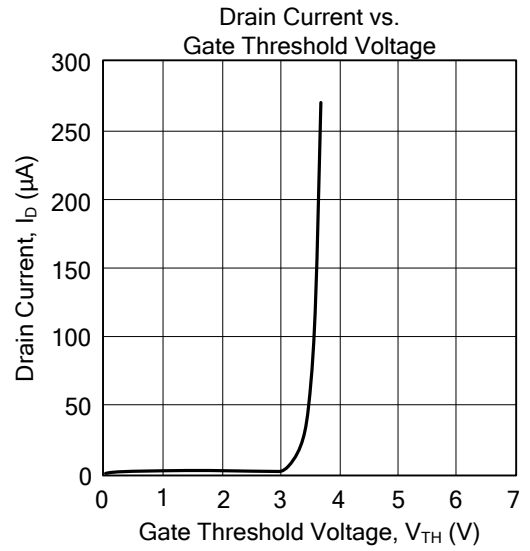
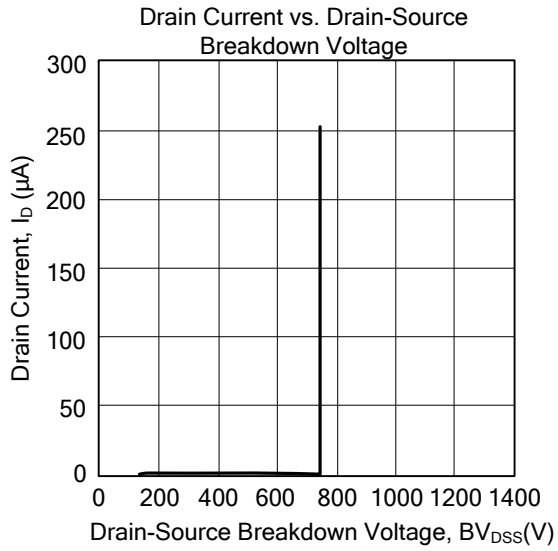

■ TO-251F-3L PACKAGE OUTLINE DIMENSIONS

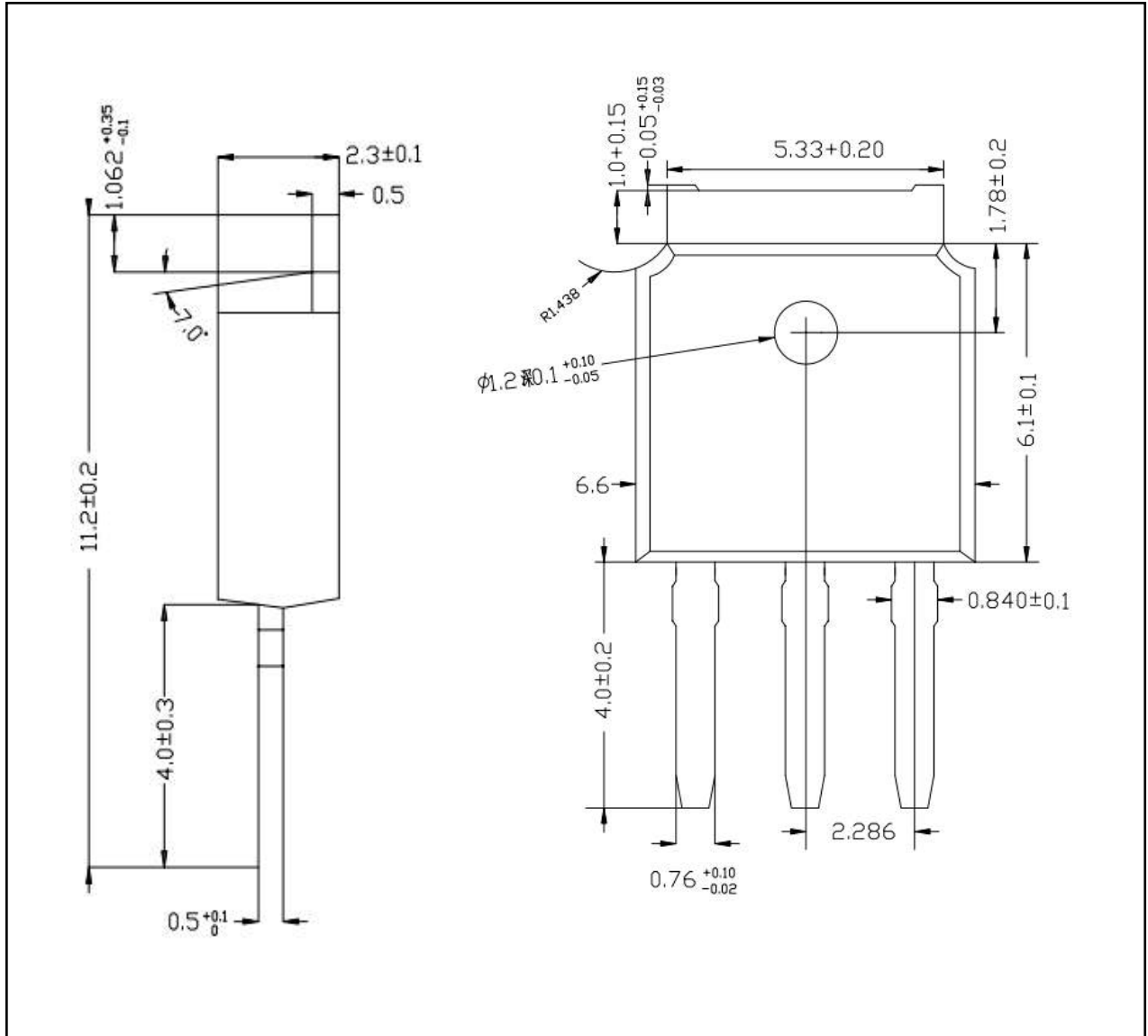

■ TO-252F-2L PACKAGE OUTLINE DIMENSIONS

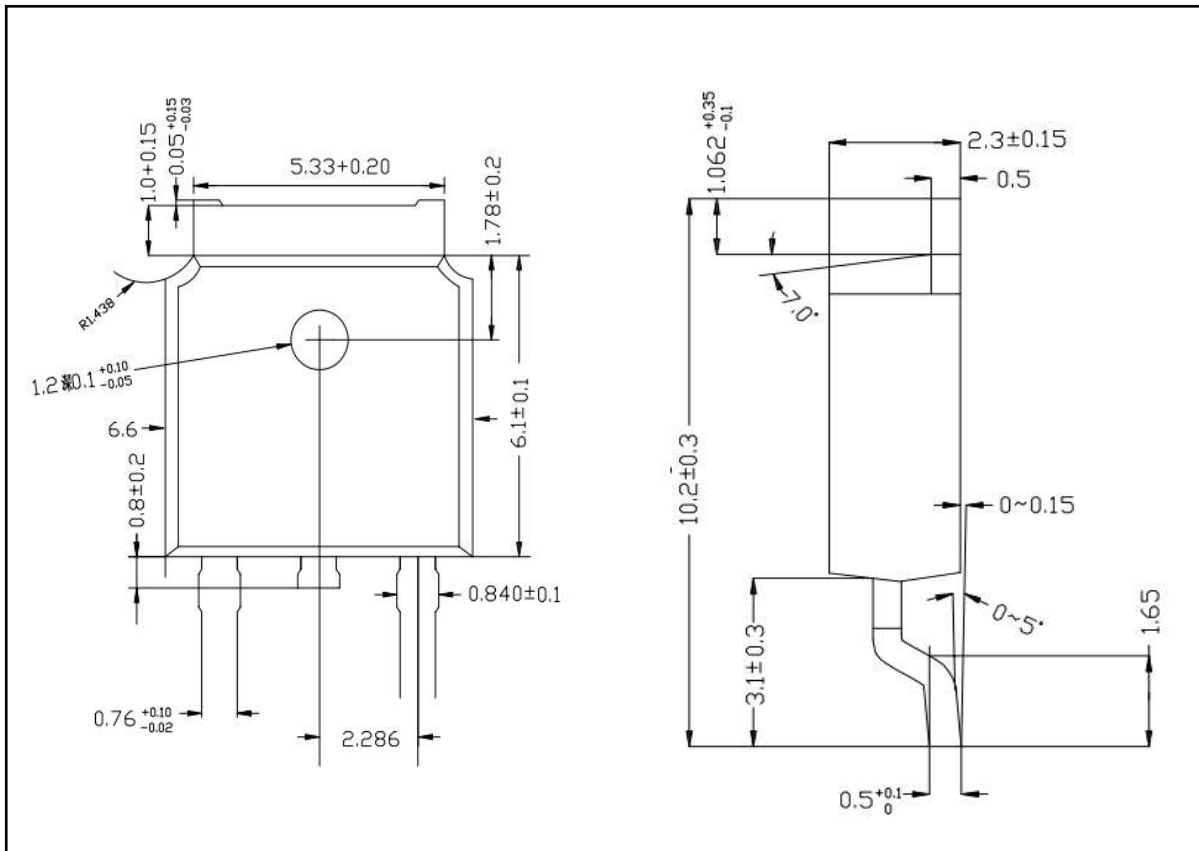

## X-ON Electronics

Largest Supplier of Electrical and Electronic Components

*Click to view similar products for [MOSFET](#) category:*

*Click to view products by [MOT](#) manufacturer:*

Other Similar products are found below :

[IRFD120](#) [JANTX2N5237](#) [BUK455-60A/B](#) [MIC4420CM-TR](#) [VN1206L](#) [NDP4060](#) [SI4482DY](#) [IPS70R2K0CEAKMA1](#) [SQD23N06-31L-GE3](#)  
[TK16J60W,S1VQ\(O](#) [2SK2614\(TE16L1,Q\)](#) [DMN1017UCP3-7](#) [DMN1053UCP4-7](#) [SQJ469EP-T1-GE3](#) [NTE2384](#) [DMC2700UDMQ-7](#)  
[DMN2080UCB4-7](#) [DMN61D9UWQ-13](#) [US6M2GTR](#) [DMN31D5UDJ-7](#) [DMP22D4UFO-7B](#) [DMN1006UCA6-7](#) [DMN16M9UCA6-7](#)  
[STF5N65M6](#) [IRF40H233XTMA1](#) [STU5N65M6](#) [DMN6022SSD-13](#) [DMN13M9UCA6-7](#) [DMTH10H4M6SPS-13](#) [DMN2990UFB-7B](#)  
[IPB80P04P405ATMA2](#) [2N7002W-G](#) [MCAC30N06Y-TP](#) [MCQ7328-TP](#) [BXP7N65D](#) [BXP4N65F](#) [AOL1454G](#) [WMJ80N60C4](#) [BXP2N20L](#)  
[BXP2N65D](#) [BXT1150N10J](#) [BXT1700P06M](#) [TSM60NB380CP](#) [ROG](#) [RQ7L055BGTCR](#) [DMNH15H110SK3-13](#) [SLF10N65ABV2](#)  
[BSO203SP](#) [BSO211P](#) [IPA60R230P6](#) [IPA60R460CE](#)