

■ PRODUCT CHARACTERISTICS

V_{DSS}	60V
$R_{DS(ON)}$ Typ(@ $V_{GS}=10V$)	8m Ω
$R_{DS(ON)}$ Typ(@ $V_{GS}=4.5V$)	10m Ω
I_D	50A

■ APPLICATIONS

- Portable Equipment and Battery Powered systems.
- Power Management in Notebook Computer

■ FEATURES

- Lower $R_{DS(ON)}$ to Minimize Conduction Losses
- Reliable and Rugged
- ROHS Compliant & Halogen-Free
- 100% UIS and Rg Tested

■ ORDER INFORMATION

Order codes		Package	Packing
Halogen-free	Halogen		
N/A	MOT6180G	PDFN5X6-8L	5000 pieces/Reel

■ ABSOLUTE MAXIMUM RATINGS ($T_J=25^{\circ}C$ Unless Otherwise Noted)

PARAMETER	SYMBOL	RATINGS	UNIT	
Drain-Source Voltage	V_{DSS}	60	V	
Gate-Source Voltage	V_{GSS}	± 20	V	
Drain Current	$T_C=25^{\circ}C$	I_D	50	A
	$T_C=100^{\circ}C$	I_D	39	A
Plused Drain Current	I_{DM}	200	A	
Avalanche Energy	E_{AS}	350	mJ	
Power Dissipation	P_D	60	W	
Thermal Resistance, Junction-to-Case	$R_{\theta JC}$	2.1	$^{\circ}C/W$	
Junction Temperature	T_J	+150	$^{\circ}C$	
Storage Temperature Range	T_{STG}	-55 ~ +150	$^{\circ}C$	

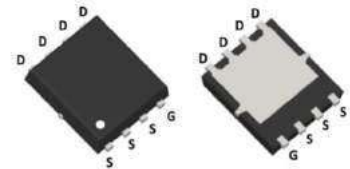
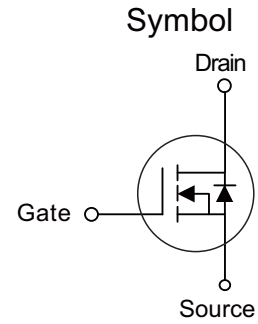

■ ELECTRICAL CHARACTERISTICS (T =25°C unless otherwise specified)

Parameter	Symbol	Condition	Min	Typ	Max	Unit
Off characteristics						
Drain-Source Breakdown Voltage	BV_{DSS}	$V_{GS}=0V, I_D=250\mu A$	60	-	-	V
Zero Gate Voltage Drain Current	I_{DSS}	$V_{DS}=60V, V_{GS}=0V$	-	-	1	μA
Gate-Body Leakage Current	I_{GSS}	$V_{GS}=\pm 20V, V_{DS}=0V$	-	-	± 100	nA
On characteristics						
Gate Threshold Voltage	$V_{GS(th)}$	$V_{DS}=V_{GS}, I_D=250\mu A$	1.2	1.8	2.5	V
Drain-Source On-State Resistance	$R_{DS(ON)}$	$V_{GS}=10V, I_D=25A$	-	8	9	m Ω
		$V_{GS}=4.5V, I_D=25A$	-	10	12	m Ω
Forward Transconductance	g_{FS}	$V_{DS}=5V, I_D=25A$	10	-	-	S
Dynamic characteristics						
Input Capacitance	C_{iss}	$V_{DS}=20V, V_{GS}=0V,$ $F=1.0MHz$	-	1100	-	PF
Output Capacitance	C_{oss}		-	360	-	PF
Reverse Transfer Capacitance	C_{rss}		-	19.2	-	PF
Switching characteristics						
Turn-on Delay Time	$t_{d(on)}$	$V_{DD}=30V, I_D=25A$ $V_{GS}=10V, R_G=1.6\Omega$	-	8	-	nS
Turn-on Rise Time	t_r		-	2	-	nS
Turn-Off Delay Time	$t_{d(off)}$		-	29	-	nS
Turn-Off Fall Time	t_f		-	4	-	nS
Total Gate Charge	Q_g	$V_{DS}=30V, I_D=25A,$ $V_{GS}=10V$	-	34.8	-	nC
Gate-Source Charge	Q_{gs}		-	7	-	nC
Gate-Drain Charge	Q_{gd}		-	5.3	-	nC
Drain-source diode characteristics						
Diode Forward Voltage	V_{SD}	$V_{GS}=0V, I_S=25A$	-	-	1.2	V
Diode Forward Current	I_S		-	-	50	A
Reverse Recovery Time	t_{rr}	$T_J = 25^\circ C, I_F = 25A$ $di/dt = 100A/\mu s$	-	38	-	nS
Reverse Recovery Charge	Q_{rr}		-	48	-	nC

■ TYPICAL CHARACTERISTICS

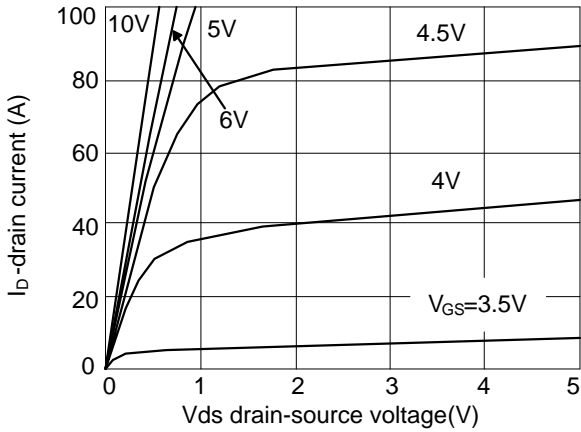

Figure 1 Output characteristics

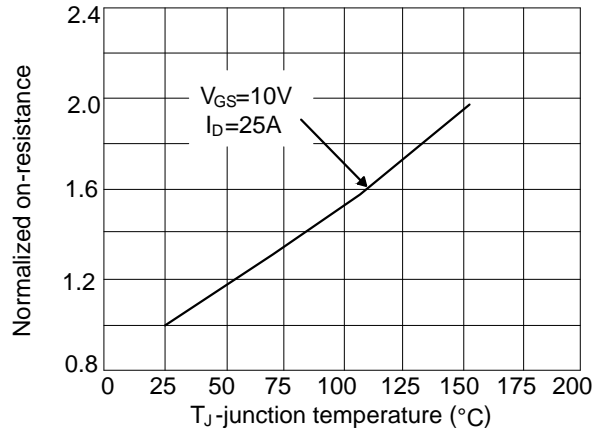

Figure 2 $R_{DS(on)}$ -junction temperature

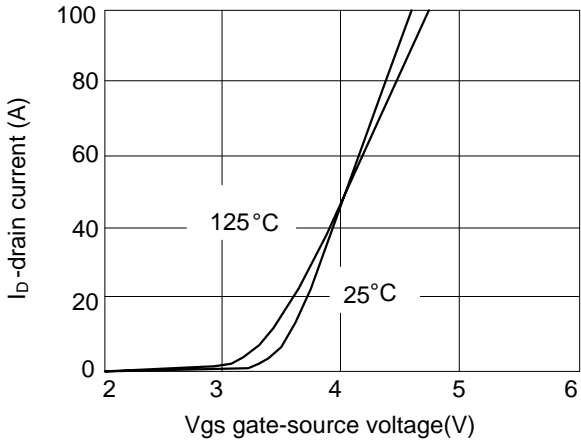

Figure 3 Transfer characteristics

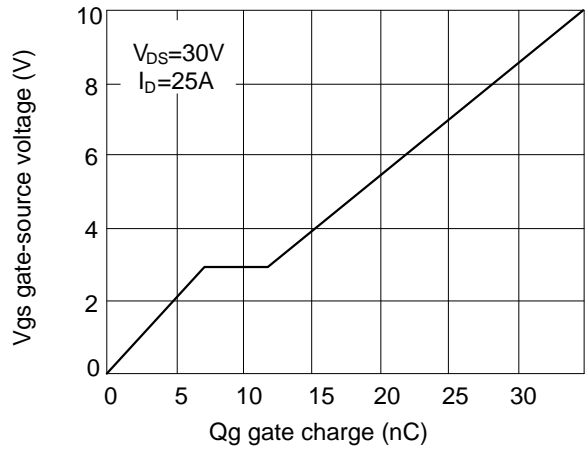

Figure 4 Gate charge

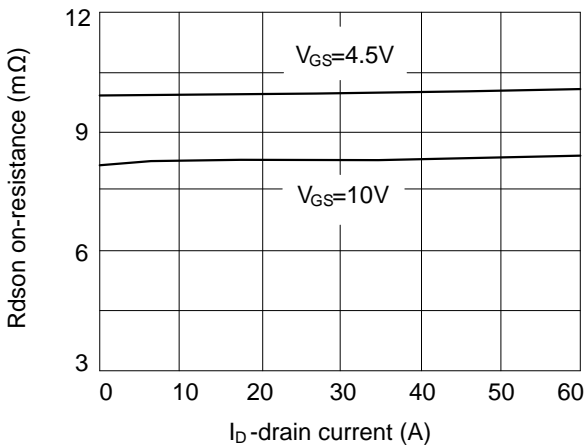

Figure 5 $R_{DS(on)}$ -drain current

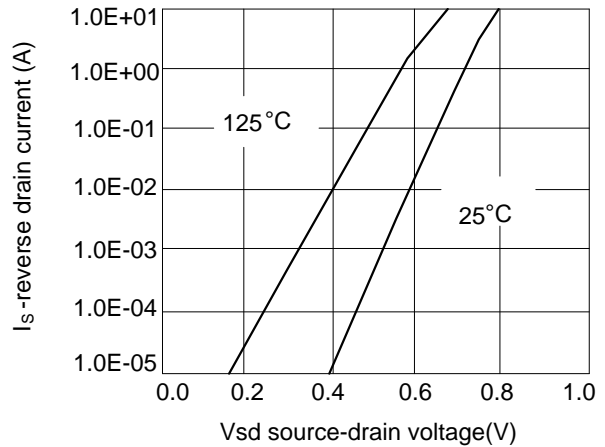

Figure 6 Source-drain diode forward

■ TYPICAL CHARACTERISTICS(Cont.)

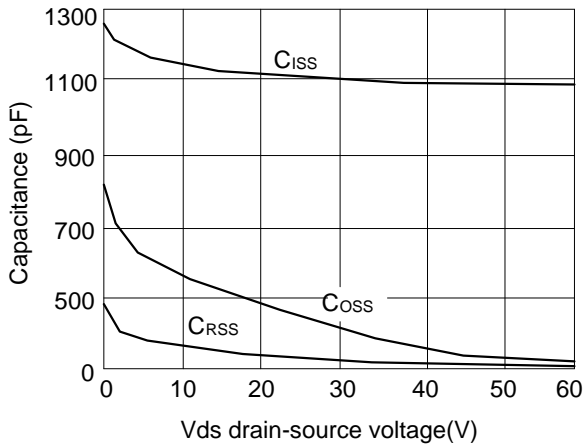

Figure 7 Capacitance vs vds

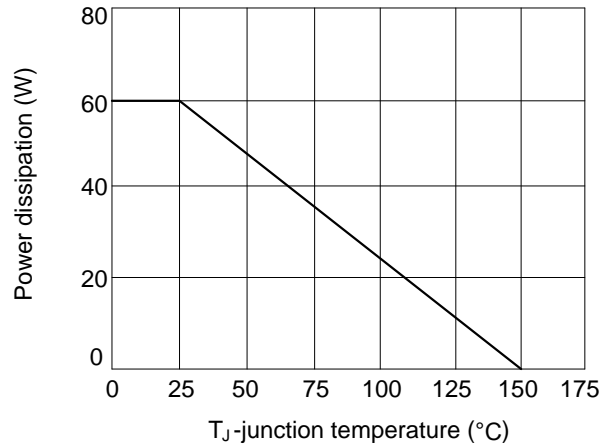

Figure 8 Power de-rating

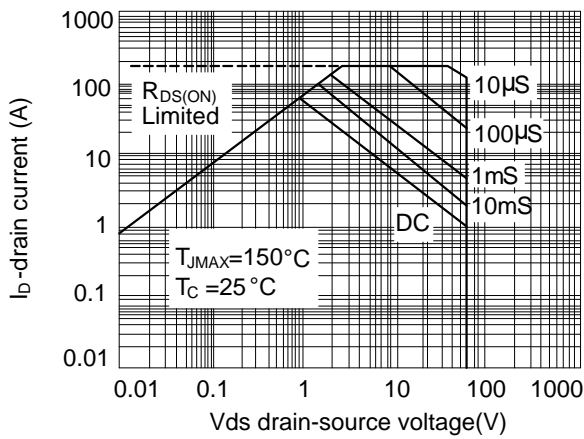

Figure 9 Safe operation area

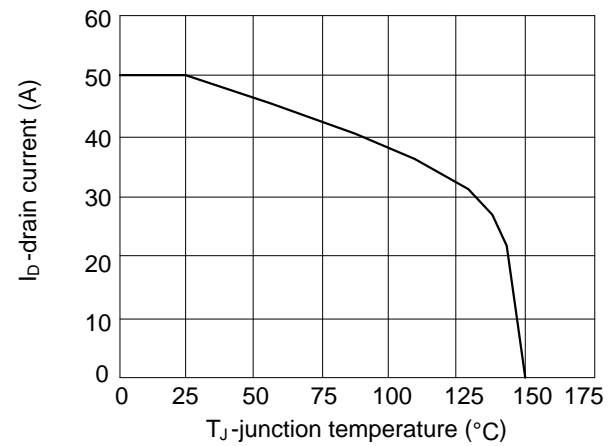
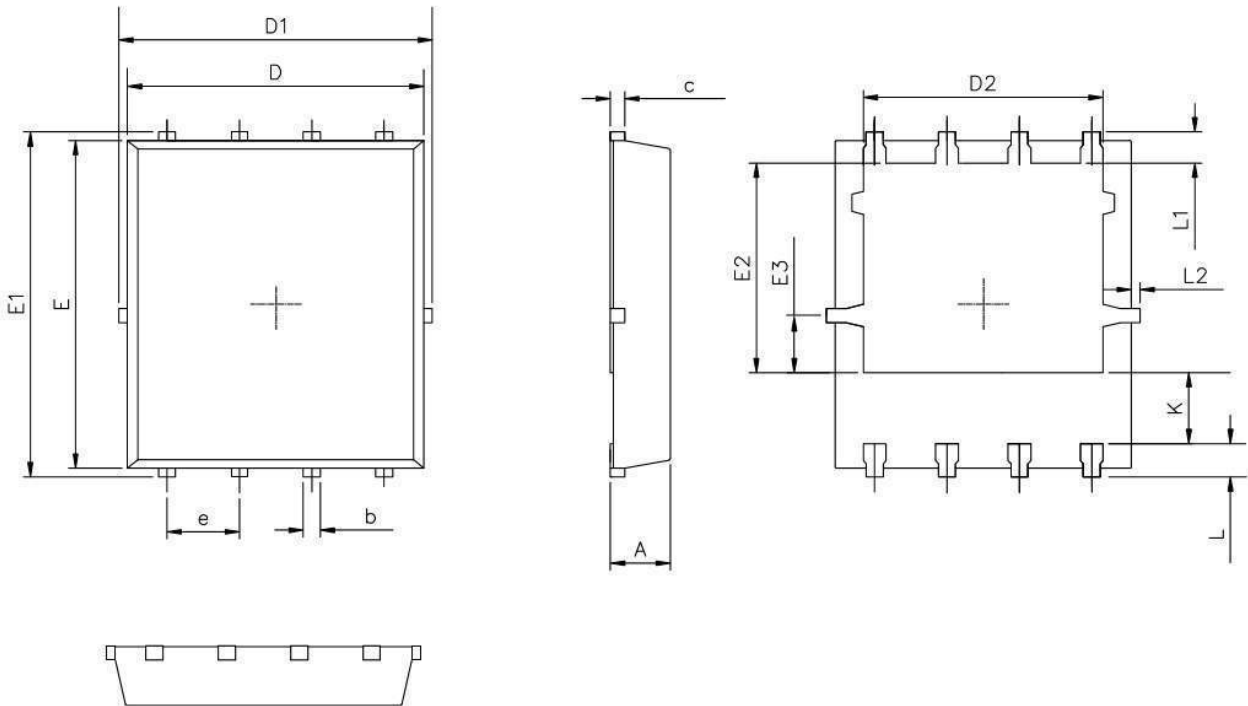
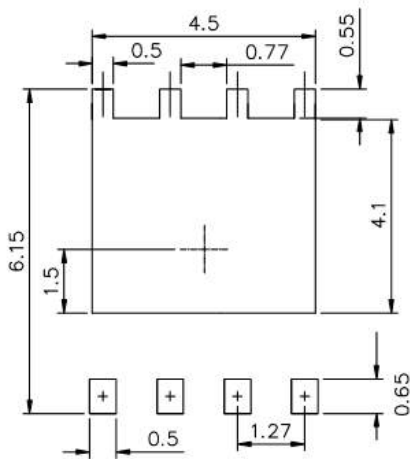

Figure 10 Current de-rating

PDFN5X6-8L PACEAGE MECHANICAL DATA



RECOMMENDED LAND PATTERN



UNIT:mm

	MIN	NOM	MAX
A	0.90	1.00	1.10
b	0.25	0.35	0.50
c	0.10	0.20	0.30
D	4.80	5.00	5.30
D1	4.90	5.10	5.50
D2	3.92	4.02	4.20
E	5.65	5.75	5.85
E1	5.90	6.05	6.20
E2	3.325	3.525	3.775
E3	0.80	0.90	1.00
e		1.27	
L	0.40	0.55	0.70
L1		0.65	
L2	0.00		0.15
K	1.00	1.30	1.50

X-ON Electronics

Largest Supplier of Electrical and Electronic Components

Click to view similar products for [MOSFET](#) category:

Click to view products by [MOT](#) manufacturer:

Other Similar products are found below :

[IRFD120](#) [IRFY240C](#) [JANTX2N5237](#) [2SK2267\(Q\)](#) [BUK455-60A/B](#) [MIC4420CM-TR](#) [VN1206L](#) [NDP4060](#) [SI4482DY](#)
[IPS70R2K0CEAKMA1](#) [SQD23N06-31L-GE3](#) [TK16J60W,S1VQ\(O](#) [2SK2614\(TE16L1,Q\)](#) [DMN1017UCP3-7](#) [EFC2J004NUZTDG](#)
[DMN1053UCP4-7](#) [SQJ469EP-T1-GE3](#) [NTE2384](#) [DMC2700UDMQ-7](#) [DMN2080UCB4-7](#) [DMN61D9UWQ-13](#) [US6M2GTR](#)
[DMN31D5UDJ-7](#) [DMP22D4UFO-7B](#) [DMN1006UCA6-7](#) [DMN16M9UCA6-7](#) [STF5N65M6](#) [IRF40H233XTMA1](#) [STU5N65M6](#)
[DMN6022SSD-13](#) [DMN13M9UCA6-7](#) [DMTH10H4M6SPS-13](#) [DMN2990UFB-7B](#) [IPB80P04P405ATMA2](#) [2N7002W-G](#) [MCAC30N06Y-](#)
[TP](#) [MCQ7328-TP](#) [NTMC083NP10M5L](#) [NVMFS2D3P04M8LT1G](#) [BXP7N65D](#) [BXP4N65F](#) [AOL1454G](#) [WMJ80N60C4](#) [BXP2N20L](#)
[BXP2N65D](#) [BXT1150N10J](#) [BXT1700P06M](#) [TSM60NB380CP](#) [ROG](#) [RQ7L055BGTCR](#) [DMNH15H110SK3-13](#)