

■ PRODUCT CHARACTERISTICS

VDSS	30V
R _{DS(on)} Typ(@V _{GS} =10V)	4.2mΩ
R _{DS(on)} Typ(@V _{GS} =4.5 V)	6.5mΩ
ID	90A

■ DESCRIPTION

This is suitable for the most demanding DC-DC converter application where high efficiency is to be achieved.

■ FEATURES

- * R_{DS(on)}*Q_G industry's benchmark
- * Conduction losses reduced
- * Switching losses reduced
- * Low threshold device

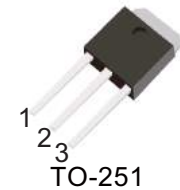
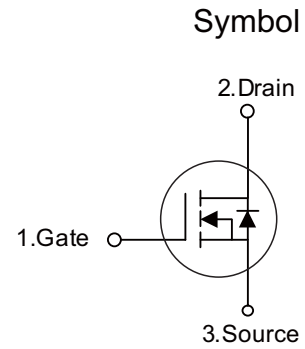

■ ORDER INFORMATION

Order codes		Package	Packing
Halogen-Free	Halogen		
N/A	MOT90N03D	TO-252	2500 pieces /Reel
N/A	MOT90N03C	TO-251	70 pieces/Tube

■ ABSOLUTE MAXIMUM RATINGS

Parameter	Symbol	Value	Unit
Drain-source voltage (V _{GS} = 0)	V _{DS}	30	V
Gate-source voltage	V _{GS}	±20	V
Drain current (continuous) at T _C = 25°C	I _D ⁽¹⁾	90	A
Drain current (continuous) at T _C =100°C	I _D	72	A
Drain current (pulsed)	I _{DM} ⁽²⁾	320	A
Total dissipation at T _C = 25°C	P _{TOT}	95	W
Derating factor		0.63	W/°C
Single pulse avalanche energy	E _{AS} ⁽³⁾	350	mJ
Operating and Storage junction temperature	T _J T _{stg}	-55 to 150	°C

■ THERMAL DATA

Parameter	Symbol	Value	Unit
Thermal resistance junction-case max	R _{thj-case}	1.58	°C/W
Thermal resistance junction-ambient max	R _{thj-amb}	100	°C/W

1. Value limited by wire bonding
2. Pulse width limited by safe operating area
3. Starting T_J = 25°C, I_D =40A, V_{DD} =15V

■ ELECTRICAL CHARACTERISTICS ($T_c = 25^\circ\text{C}$, unless otherwise specified)

Parameter	Symbol	Conditions	Min	Typ	Max	Unit
Drain-source breakdown voltage	$V_{(BR)DSS}$	$I_D = 250\mu\text{A}, V_{GS} = 0$	30	-	-	V
Zero gate voltage drain current ($V_{GS} = 0$)	I_{DSS}	$V_{DS} = 30\text{V}$	-	-	1	μA
		$V_{DS} = 30\text{V}, T_c = 125^\circ\text{C}$	-	-	10	μA
Gate body leakage current ($V_{DS} = 0$)	I_{GSS}	$V_{GS} = \pm 20\text{V}$	-	-	± 100	nA
Gate threshold voltage	$V_{GS(th)}$	$V_{DS} = V_{GS}, I_D = 250\mu\text{A}$	1	-	-	V
Static drain-source on resistance	$R_{DS(on)}$	$V_{GS} = 10\text{V}, I_D = 40\text{A}$	-	4.2	5.5	m Ω
		$V_{GS} = 4.5\text{V}, I_D = 40\text{A}$	-	6.5	8	
Input capacitance	C_{iss}	$V_{DS} = 25\text{V}, f = 1\text{MHz}, V_{GS} = 0$	-	2805	-	pF
Output capacitance	C_{oss}		-	549	-	pF
Reverse transfer capacitance	C_{rss}		-	76	-	pF
Total gate charge	Q_g	$V_{DD} = 15\text{V}, I_D = 80\text{A}$	-	22	32	nC
Gate-source charge	Q_{gs}	$V_{GS} = 5\text{V}$	-	10	-	nC
Gate-drain charge	Q_{gd}	(see Figure 13)	-	7	-	nC
Gate input resistance	R_G	f=1MHz Gate Bias Bias=0 Test Signal	-	1.2	-	Ω
Turn-on delay time	$t_{d(on)}$	$V_{DD} = 15\text{V}, I_D = 40\text{A}, R_G = 4.7\Omega, V_{GS} = 5\text{V}$ (see Figure 12)	-	19	-	ns
Rise time	t_r		-	135	-	ns
Turn-off delay time	$t_{d(off)}$		-	24	-	ns
Fall time	t_f		-	33	-	ns
Source-drain current	I_{SD}		-	-	80	A
Source-drain current (pulsed)	$I_{SDM}^{(1)}$		-	-	320	A
Forward on voltage	$V_{SD}^{(2)}$	$I_{SD} = 40\text{A}, V_{GS} = 0$	-	-	1.3	V
Reverse recovery time	t_{rr}	$I_{SD} = 80\text{A}, di/dt = 100\text{A}/\mu\text{s}$,	-	36	-	ns
Reverse recovery charge	Q_{rr}	$V_{DD} = 19\text{V}, T_j = 150^\circ\text{C}$	-	32	-	μC
Reverse recovery current	I_{RRM}	(see Figure 15)	-	1.8	-	A

1. Pulse width limited by safe operating area
2. Pulsed: pulse duration=300 μs , duty cycle 1.5%

■ TYPICAL CHARACTERISTICS

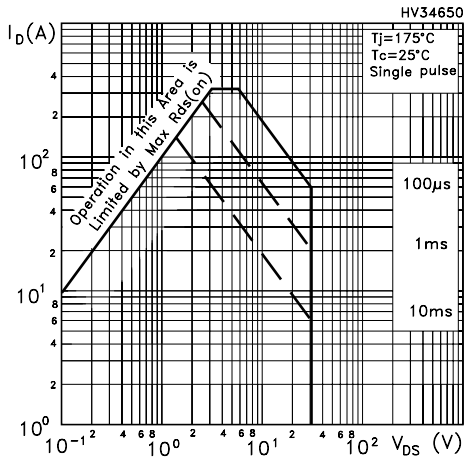

Figure 1. Safe operating area

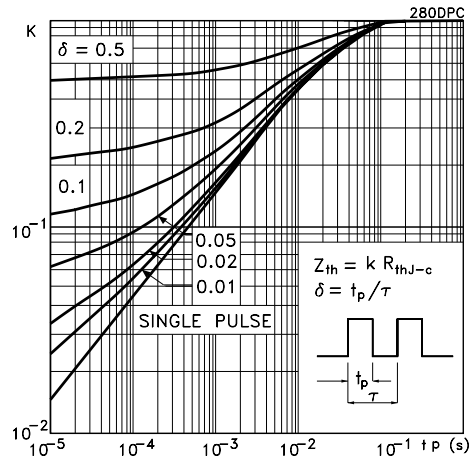

Figure 2. Thermal impedance

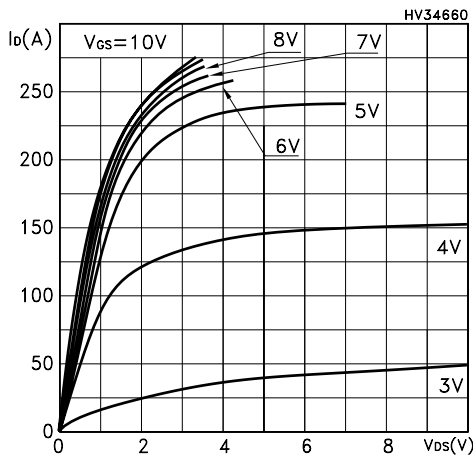

Figure 3. Output characteristics

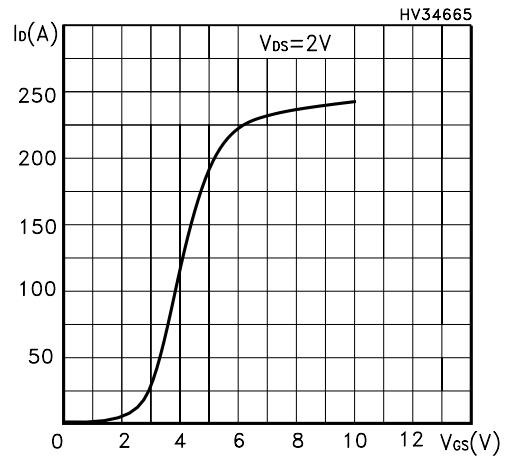

Figure 4. Transfer characteristics

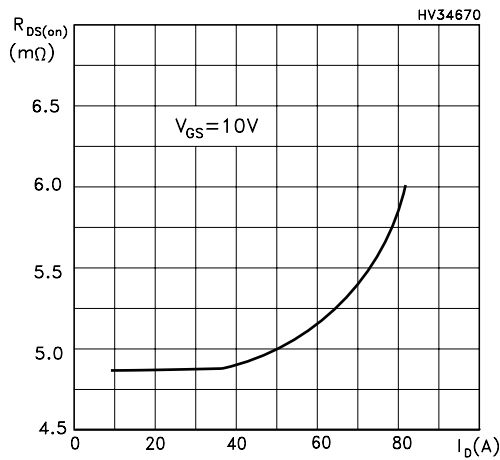

Figure 5. Static drain-source on resistance

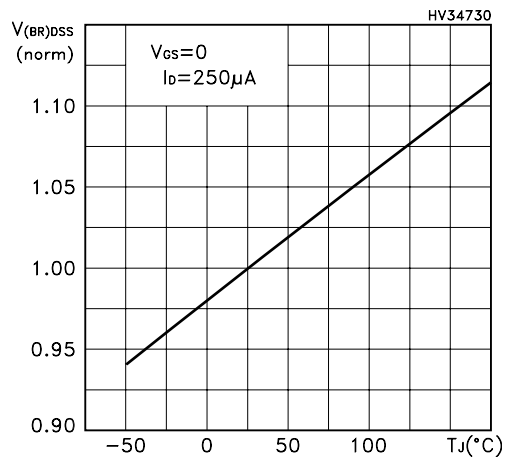

Figure 6. Normalized B_{VDSS} vs temperature

■ TYPICAL CHARACTERISTICS(Cont.)

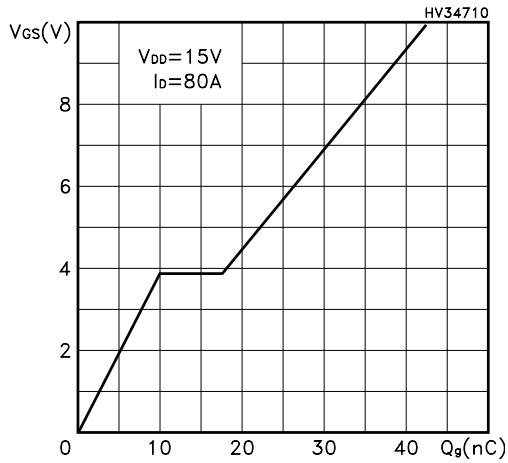

Figure 7. Gate charge vs gate-source voltage

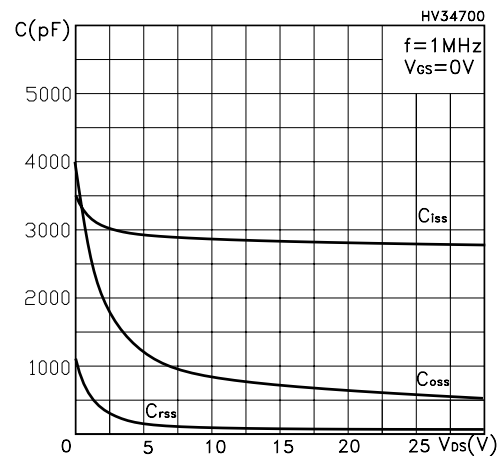

Figure 8. Capacitance variations

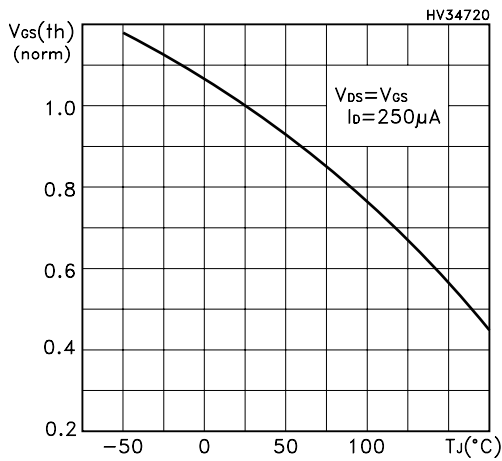

Figure 9. Normalized gate threshold voltage vs temperature

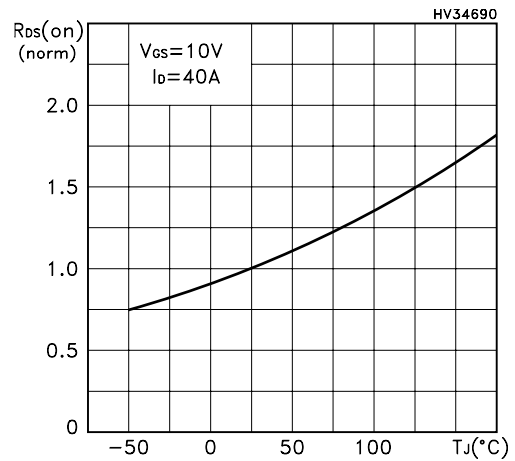

Figure 10. Normalized on resistance vs temperature

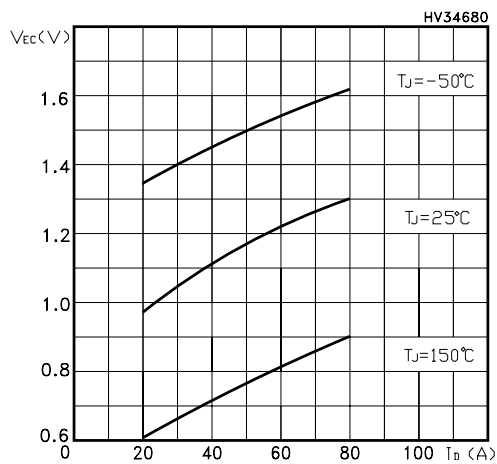
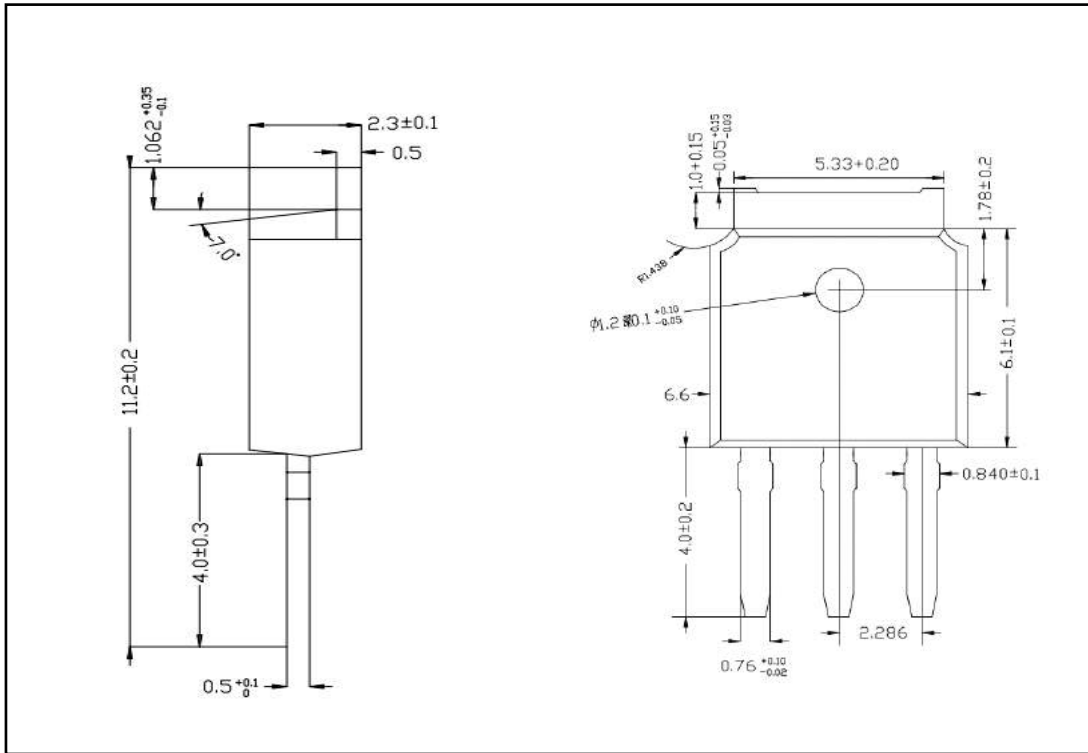
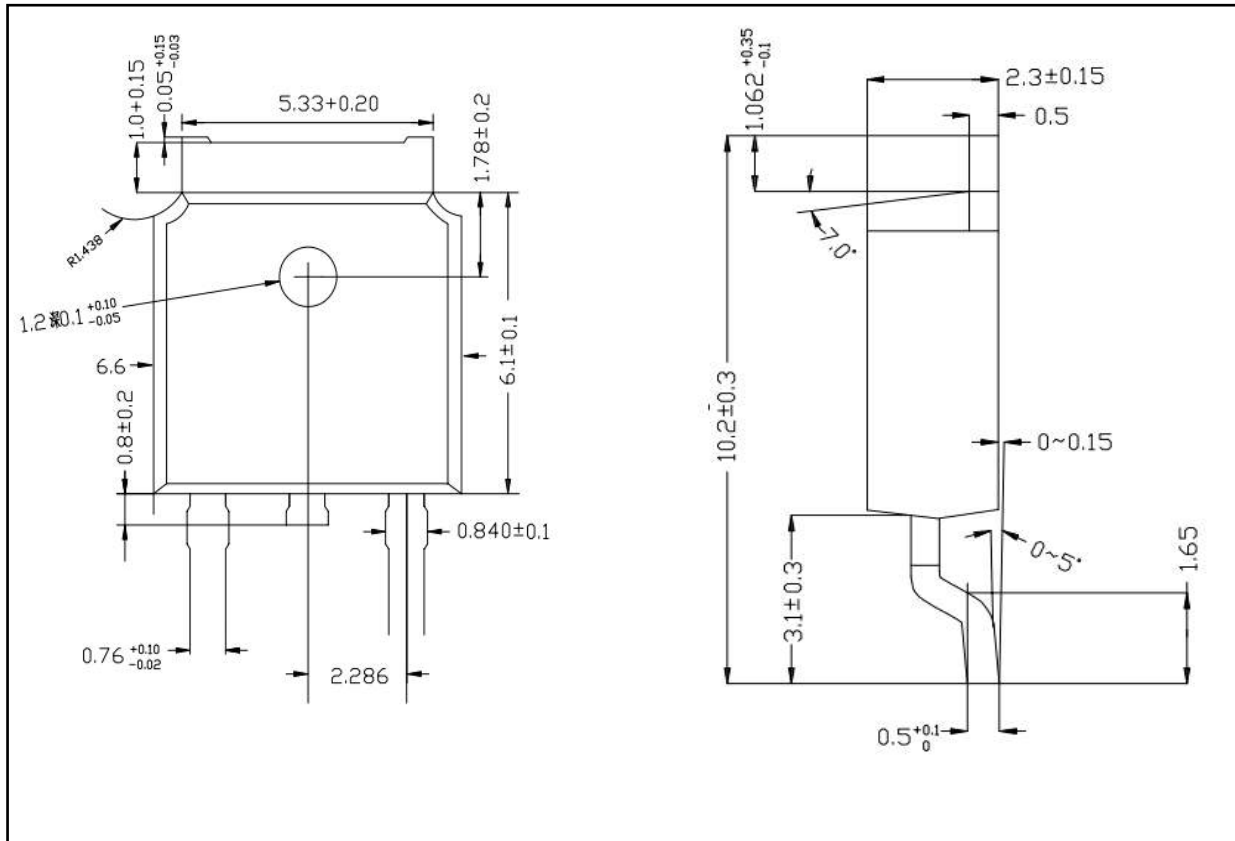

Figure 11. Source-drain diode forward characteristics

■ TO-251 PACKAGE OUTLINE DIMENSIONS



■ TO-252 PACKAGE OUTLINE DIMENSIONS



X-ON Electronics

Largest Supplier of Electrical and Electronic Components

Click to view similar products for [MOSFET](#) category:

Click to view products by [MOT](#) manufacturer:

Other Similar products are found below :

[IRFD120](#) [JANTX2N5237](#) [BUK455-60A/B](#) [MIC4420CM-TR](#) [VN1206L](#) [NDP4060](#) [SI4482DY](#) [IPS70R2K0CEAKMA1](#) [SQD23N06-31L-GE3](#)
[TK16J60W,S1VQ\(O](#) [2SK2614\(TE16L1,Q\)](#) [DMN1017UCP3-7](#) [DMN1053UCP4-7](#) [SQJ469EP-T1-GE3](#) [NTE2384](#) [DMC2700UDMQ-7](#)
[DMN2080UCB4-7](#) [DMN61D9UWQ-13](#) [US6M2GTR](#) [DMN31D5UDJ-7](#) [DMP22D4UFO-7B](#) [DMN1006UCA6-7](#) [DMN16M9UCA6-7](#)
[STF5N65M6](#) [IRF40H233XTMA1](#) [STU5N65M6](#) [DMN6022SSD-13](#) [DMN13M9UCA6-7](#) [DMTH10H4M6SPS-13](#) [DMN2990UFB-7B](#)
[IPB80P04P405ATMA2](#) [2N7002W-G](#) [MCAC30N06Y-TP](#) [MCQ7328-TP](#) [BXP7N65D](#) [BXP4N65F](#) [AOL1454G](#) [WMJ80N60C4](#) [BXP2N20L](#)
[BXP2N65D](#) [BXT1150N10J](#) [BXT1700P06M](#) [TSM60NB380CP](#) [ROG](#) [RQ7L055BGTCR](#) [DMNH15H110SK3-13](#) [SLF10N65ABV2](#)
[BSO203SP](#) [BSO211P](#) [IPA60R230P6](#) [IPA60R460CE](#)